



## 2013 PRODUCT CATALOGUE

**FREECALL** 1300 265 800

**EMAIL** [sales@garrisonsolutions.com.au](mailto:sales@garrisonsolutions.com.au) **WEBSITE** [www.garrisonsolutions.com.au](http://www.garrisonsolutions.com.au)

**FREECALL** 1300 265 800

**EMAIL** [sales@garrisonsolutions.com.au](mailto:sales@garrisonsolutions.com.au) **WEBSITE** [www.garrisonsolutions.com.au](http://www.garrisonsolutions.com.au)



## GARRISON BUILDING SOLUTIONS

Garrison Solutions, formerly Letterbox Installations, is an Australian owned and operated business which provides a wide range of quality products. Garrison Solutions specialize in modular mailbox units made from fully extruded aluminium. Manufacturing processes for the custom built range of mailboxes permits the dimensions of the mailbox to be altered (length, width, depth) to suit your specific project requirements.

Our mailboxes are ideal for a diverse range of projects, including apartments, office blocks, shopping centres, commercial buildings, and residential dwellings. Other applications of mailboxes are; valuables lockers, assignment boxes, document transfer boxes and pigeon holes.

New product ranges include: Clotheslines, safes, key lockers, security solutions and architectural hardware.

Garrison Solutions is committed to providing clients with a level of service and supply options that will exceed expectations. Garrison Solutions is a family business, whose parent company was established in 1927 and which has been dedicated to servicing architects and the building related industry for in excess of 80 years. In summary our maxim is...

**“Service is the constitution, quality is the character, perfection is the goal, and customer satisfaction is the result.”**

## CONTENTS

<b>Garrison Building Solutions</b>	<b>2</b>
CONTENTS	3
<b>Mailsafe Mailboxes</b>	<b>4</b>
MSF2/MSF3	5
APR2/APR3	6
MSF	7
MSF4	8
SERIES 7/SERIES 7L	9
DELTA RANGE	10
LUXUS RANGE	11
TYRO RANGE	12
STAINLESS STEEL VALUE RANGE	13
<b>Allux By Garrison Range</b>	<b>14</b>
CLASSIC SERIES	15
FRONTIER SERIES	15
ECLIPSE SERIES	15
GALAXY PARCEL SERIES	15
STANDS	15
<b>Specifications</b>	<b>18</b>
FAQ'S	19
LOGO KEY	19
COLOUR CHART	20
MAILSAFE BANK DIMENSIONS	21





## MAILSAFE MAILBOXES

With decades of experience in the industry, Mailsafe Mailboxes is one of the few Quality Assured manufacturers of mailboxes and letterboxes in Australia. Mailsafe Mailboxes is a commercial division of Help Enterprises and has been producing a high quality range of aluminium and metal fabricated products since 1972. Specialising in fully extruded high quality aluminium modular mailbox units (banks) for townhouse and unit developments, retirement villages, shopping centres and commercial premises.

One of the enhanced features of Mailsafe Mailboxes is the flat floor, which means mail cannot catch on internal protrusions as it is being delivered, eliminating the risk of mail sticking out from the aperture slot after delivery. All of our mailboxes come with a straight 30mm Weatherhood. This offers a modern and stylish finish and doesn't restrict the receipt of large quantities of mail as with mailboxes that have curved Weatherhoods. All of our mailboxes are available in your choice of either front or rear opening designs. With a focus on customer service, Garrison Solutions together with Mailsafe Mailboxes offers clients a total solution.

When you are dealing with Garrison Solutions you are buying a quality Australian-made product and assisting us in supporting the independence of people with disabilities.

### MSF2/MSF3

Designed to reduce lead times and allow customers to have their mailbox on demand, the MSF range has revolutionised the mailbox industry.

MSF2 and MSF3 mailboxes are capable of receiving large quantities of mail, including A4 envelopes and magazines without folding. The MSF3 is especially suited to situations where width restrictions apply, as the box is narrower across the front and deeper.

Setting the MSF range apart from the competition is the special feature of a silicone sealant. This is added to all roof joints providing additional protection from the rain. An extra benefit is that all external rivets and screws are counter-sunk for a safer and neater look. The MSF range meets the design requirements of Australia Post.

Available in either front or rear opening designs.

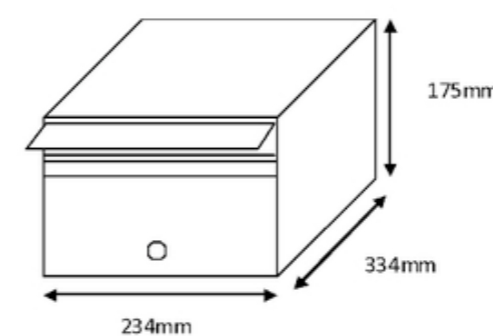
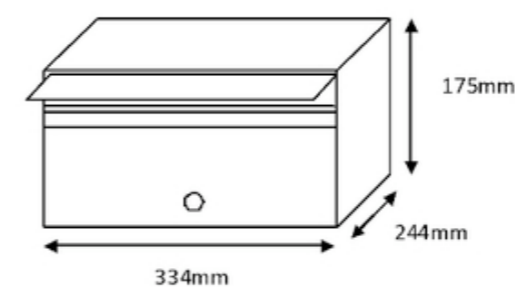

#### Standard Features

- 30mm Aperture Slot - large enough to receive bulky mail though small enough to provide mail security
- 30mm Weatherhood provides mail security and weather protection
- Wide Range of Colours - offers flexibility to match your décor
- Double-Sided Keys - for better security and greater number of unique keys for multi-residential installations
- Substantial protective packaging ensures your mailbox arrives safe and sound, regardless of its destination

#### Optional Features

- Aperture Flaps
- Master Keys - ideal for Body Corporate and On-Site Managers
- Intercom/Multi-Functional Panels - ideal for co-ordinating security features with your entrance
- Number or Name Panels - ideal for large complexes and easy recognition
- 70mm x 70mm Aluminium Stands - ideal for freestanding banks of mailboxes
- Parcel or Open Shelves - ideal for residents expecting delivery of large parcels
- 20mm, 32mm, 50mm or 100mm Surround Trim - ideal for flush mounted installation into a wall
- Replacement Key and Strip Service
- Delivery of Mailboxes to Site
- On-Site Installation (Conditions Apply)
- Newspaper tubes – allows residents to neatly receive their newspapers
- Flat door with no engraved strip

PC AN A4 10 15





### APR2/APR3

The APR2 and APR3 are Australia Post Recommended mailboxes.

These mailboxes can be manufactured as a standard sized mailbox, or as a custom built mailbox to suit design or dimensional requirements.

The flat-floored APR2 and APR3 are large enough to receive an A4 envelope or magazine without folding or accidental protrusion. The APR3 is especially suited to situations where width restrictions apply, as the box is narrower across the front and deeper.

All features of the MSF range are incorporated in these mailboxes. However, APR mailboxes are slightly larger than the MSF mailboxes and feature sturdy individual framework around each bank or single mailbox. This provides even greater mail security.

Available in either front or rear opening designs.

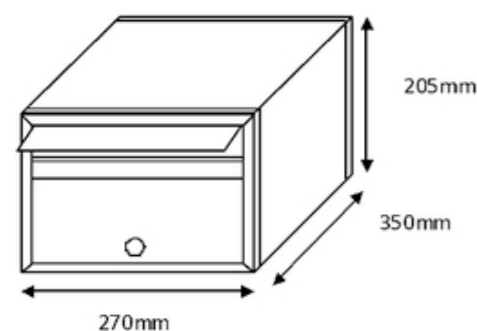
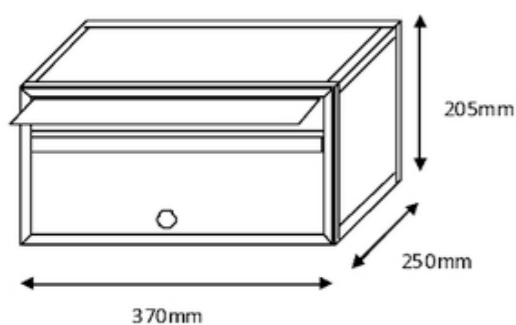

#### Standard Features

- 30mm Aperture Slot - large enough to receive bulky mail though small enough to provide mail security
- 30mm Weatherhood provides mail security and weather protection
- Wide Range of Colours - offers flexibility to match your décor
- Double-Sided Keys - for better security and greater number of unique keys for multi-residential installations
- Substantial protective packaging ensures your mailbox arrives safe and sound, regardless of its destination

#### Optional Features

- Aperture Flaps
- Master Keys - ideal for Body Corporate and On-Site Managers
- Intercom/Multi-Functional Panels - ideal for co-ordinating security features with your entrance
- Number or Name Panels - ideal for large complexes and easy recognition
- 70mm x 70mm Aluminium Stands - ideal for freestanding banks of mailboxes
- Parcel or Open Shelves - ideal for residents expecting delivery of large parcels
- 20mm, 32mm, 50mm or 100mm Surround Trim - ideal for flush mounted installation into a wall
- Replacement Key and Strip Service
- Delivery of Mailboxes to Site
- On-Site Installation (Conditions Apply)
- Newspaper boxes and tubes – allows residents to neatly receive their newspapers
- Flat door with no engraved strip
- Dimensions may be altered to suit your requirements



### MSF

Suitable for Resort Complexes and Hotel Style Accommodation where mail is delivered and then internally sorted.

This range can be manufactured for the use as pigeon holes which make sorting and retrieving mail neat and efficient.

The MSF Compact mailboxes are approximately half the width of the standard MSF3 mailbox, they are most suitable where large quantities are needed with a small amount room available.

Available in either front or rear opening designs.

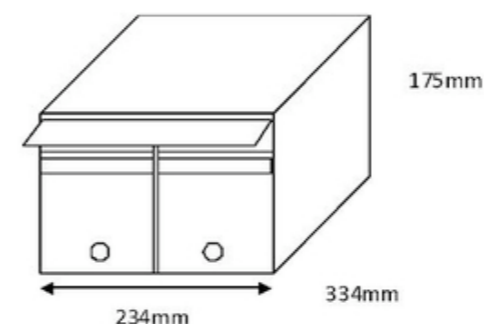
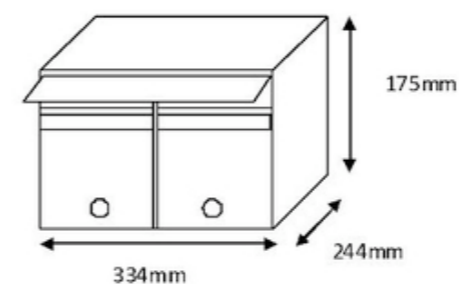

#### Standard Features

- 30mm Aperture Slot - large enough to receive bulky mail though small enough to provide mail security
- 30mm Weatherhood provides mail security and weather protection
- Wide Range of Colours - offers flexibility to match your décor
- Double-Sided Keys - for better security and greater number of unique keys for multi-residential installations
- Substantial protective packaging ensures your mailbox arrives safe and sound, regardless of its destination

#### Optional Features

- Aperture Flaps
- Master Keys - ideal for Body Corporate and On-Site Managers
- Intercom/Multi-Functional Panels - ideal for co-ordinating security features with your entrance
- Number or Name Panels - ideal for large complexes and easy recognition
- 70mm x 70mm Aluminium Stands - ideal for freestanding banks of mailboxes
- Parcel or Open Shelves - ideal for residents expecting delivery of large parcels
- 20mm, 32mm, 50mm or 100mm Surround Trim - ideal for flush mounted installation into a wall
- Replacement Key and Strip Service
- Delivery of Mailboxes to Site
- On-Site Installation (Conditions Apply)
- Flat door with no engraved strip





## MSF4

The MSF4 mailboxes are part of our standard MSF range but with an individual Newspaper Shelf to each mailbox for bulky items.

MSF4 mailboxes have been designed to hold more mail than the standard MSF2 and MSF3 mailboxes as each mailbox comes with its very own newspaper shelf. Using the width of an MSF2 Mailbox and the depth of an MSF3 mailbox, the box itself is still capable of holding an A4 envelope or magazine.

Setting the MSF range apart from the competition is the special feature of a silicone sealant. This is added to all roof joints providing additional protection from the rain. An extra benefit is that all external rivets and screws are counter-sunk for a safer and neater look. The MSF range meets the design requirements of Australia Post.

Available in either front or rear opening designs.

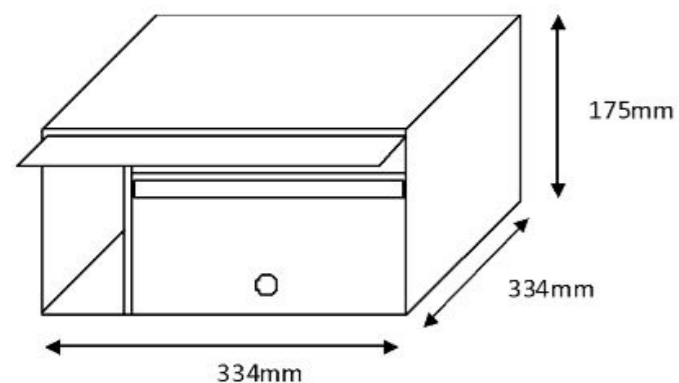

### Standard Features

- 30mm Aperture Slot - large enough to receive bulky mail though small enough to provide mail security
- 90mm Wide Newspaper Shelf to each individual mailbox
- 30mm Weatherhood provides mail security and weather protection
- Wide Range of Colours - offers flexibility to match your décor
- Double-Sided Keys - for better security and greater number of unique keys for multi-residential installations
- Substantial protective packaging ensures your mailbox arrives safe and sound, regardless of its destination

### Optional Features

- Aperture Flaps
- Master Keys - ideal for Body Corporate and On-Site Managers
- Intercom/Multi-Functional Panels - ideal for co-ordinating security features with your entrance
- Number or Name Panels - ideal for large complexes and easy recognition
- 70mm x 70mm Aluminium Stands - ideal for freestanding banks of mailboxes
- Parcel or Open Shelves - ideal for residents expecting delivery of large parcels
- 20mm, 32mm, 50mm or 100mm Surround Trim - ideal for flush mounted installation into a wall
- Replacement Key and Strip Service
- Delivery of Mailboxes to Site
- On-Site Installation (Conditions Apply)
- Flat door with no engraved strip



## SERIES 7/SERIES 7L

The Series 7 and Series 7L mailboxes are designed to fit 200mm block work installations, but are also available as freestanding units.

Series 7 mailboxes will adequately receive most residential mail but A4-sized envelopes will not fit without folding.

The Series 7L mailbox is marginally wider than the Series 7 allowing the A4 envelope to be inserted but it will not sit flat on the floor of the mailbox due to the restricted depth.

Available in either front or rear opening designs.

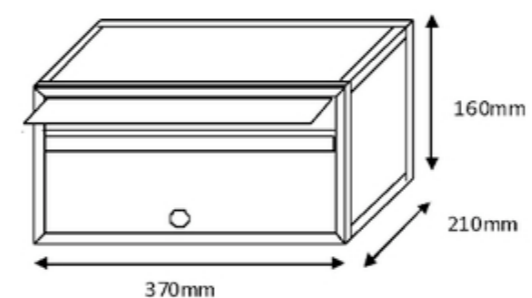
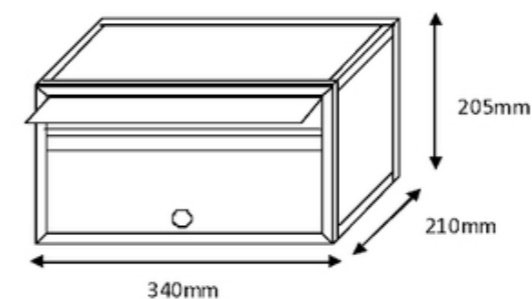

### Standard Features

- 30mm Aperture Slot - large enough to receive bulky mail though small enough to provide mail security
- 30mm Weatherhood provides mail security and weather protection
- Wide Range of Colours - offers flexibility to match your décor
- Double-Sided Keys - for better security and greater number of unique keys for multi-residential installations
- Substantial protective packaging ensures your mailbox arrives safe and sound, regardless of its destination

### Optional Features

- Aperture Flaps
- Master Keys - ideal for Body Corporate and On-Site Managers
- Intercom/Multi-Functional Panels - ideal for co-ordinating security features with your entrance
- Number or Name Panels - ideal for large complexes and easy recognition
- 70mm x 70mm Aluminium Stands - ideal for freestanding banks of mailboxes
- Parcel or Open Shelves - ideal for residents expecting delivery of large parcels
- 20mm, 32mm, 50mm or 100mm Surround Trim - ideal for flush mounted installation into a wall
- Replacement Key and Strip Service
- Delivery of Mailboxes to Site
- On-Site Installation (Conditions Apply)
- Flat door with no engraved strip







## DELTA RANGE

### MSF2-S1 Series

- Front OR Rear Opening
- Keylock OR Latch-handle
- Engraved number/name
- Powdercoat OR Anodised
- "Into-Ground" OR "Bolt-In" stands



### MSF2-UF Series

- Front OR Rear Opening
- Keylock OR Latch-handle
- Engraved number/name
- Powdercoat OR Anodised
- "Into-Ground" OR "Bolt-In" stands



### APR2-S2 Series

- Front OR Rear Opening
- Keylock OR Latch-handle
- Engraved number/name
- Powdercoat OR Anodised
- "Into-Ground" OR "Bolt-In" stands



### APR2-S1 Series

- Front OR Rear Opening
- Keylock OR Latch-handle
- Engraved number/name
- Powdercoat OR Anodised
- "Into-Ground" OR "Bolt-In" stands



## LUXUS RANGE

### S7-CP Series

- Front Opening
- Keylock OR Latch-handle
- Engraved number/name
- Powdercoat OR Anodised
- Panel with house number



### SSE Series

- Front Opening
- Keylock OR Latch-handle
- Engraved number/name
- Powdercoat OR Anodised
- Custom panel with house number

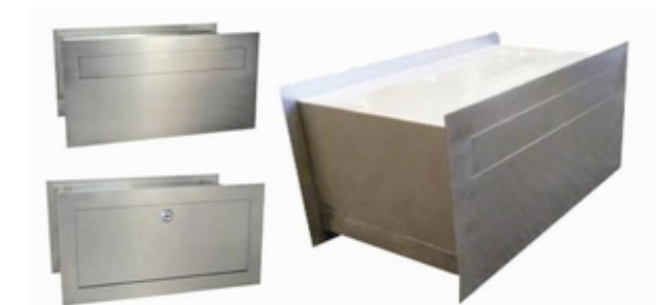

### APR2-CF Series

- Front Opening
- Keylock OR Latch-handle
- Engraved number/name
- Powdercoat OR Anodised
- Custom panel with house number



### MSF2-T32 Series

- Front OR Rear Opening
- Keylock OR Latch-handle
- Engraved number/name
- Powdercoat OR Anodised
- 32mm surround trim, can be flush with front or set back (pictured)





## TYRO RANGE

### Vega

- 100% 2mm Marine Grade (AISI 316) Stainless Steel
- High security locking with keys
- Wall Fixing included
- 405mm (w) x 535mm (h) x 135mm (d)

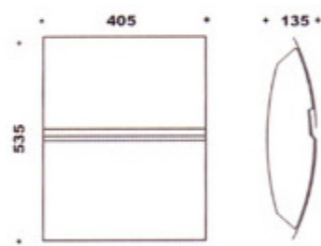

### Capella

- 100% 2mm Marine Grade (AISI 316) Stainless Steel
- High security locking with keys
- Wall Fixing included
- 360mm (w) x 490mm (h) x 130mm (d)

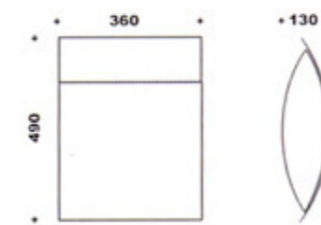

### Arcturus

- 100% 2mm Marine Grade (AISI 316) Stainless Steel
- 355mm (w) x 535mm (h) x 235mm (d)

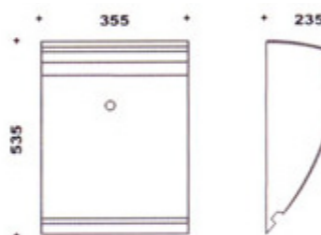

### Antares

- 100% 2mm Marine Grade (AISI 316) Stainless Steel
- High security locking with keys
- Wall Fixing included
- 340mm (w) x 445mm (h) x 135mm (d)

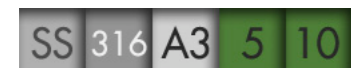
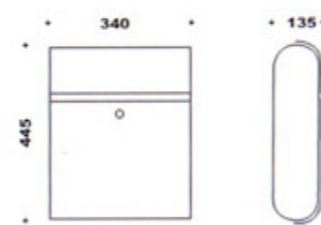

## STAINLESS STEEL VALUE RANGE

Our Stainless Steel Value Range gives you style at a reasonable price. All stainless steel construction, featuring key locks, name tags, and wall mounting fixings. Ideal for apartments, units and townhouses.

### Southampton

- All Stainless Steel Construction
- Heavy Duty Tempered Glass Door
- Key Lockable (4 Keys Included)
- Suits A4 Mail
- Ideal for Apartments, Units and Townhouses
- Replacement Glass Available
- 310mm (w) x 360mm (h) x 100mm (d)

### Floreat

- All Stainless Steel Construction
- Key Lockable (4 Keys Included)
- Name Tag Display Slot
- Ideal for Apartment, Units and Townhouses
- Wall Mounting Fixings Included
- 310mm (w) x 260mm (h) x 90mm (d)

### Ashfield

- Galvanised Steel Construction Box
- Corrugated Aluminium Front
- Newspaper Holder
- Weather Resistant
- Key Lockable
- Suits A4 Mail
- Ideal for Apartments, Units and Townhouses
- 432mm (w) x 375mm (h) x 167mm (d)

### Hilton

- All Stainless Steel Construction
- Newspaper Holder
- Suits A4 Mail
- Key Lockable
- Wall and Post Mountable
- Ideal for Apartments, Units and Townhouses

### Burswood

- All Stainless Steel Construction
- Weather Resistant
- Newspaper Holder
- Key Lockable (4 Keys Included)
- Suits A4 Mail
- Ideal for Apartments, Units and Townhouses (Fixings Incl.)

### Solar

- Galvanised Steel Construction
- Acrylic Front
- Weather Resistant
- Key Lockable
- Suits A4 Mail
- Ideal for Apartments, Units and Townhouses



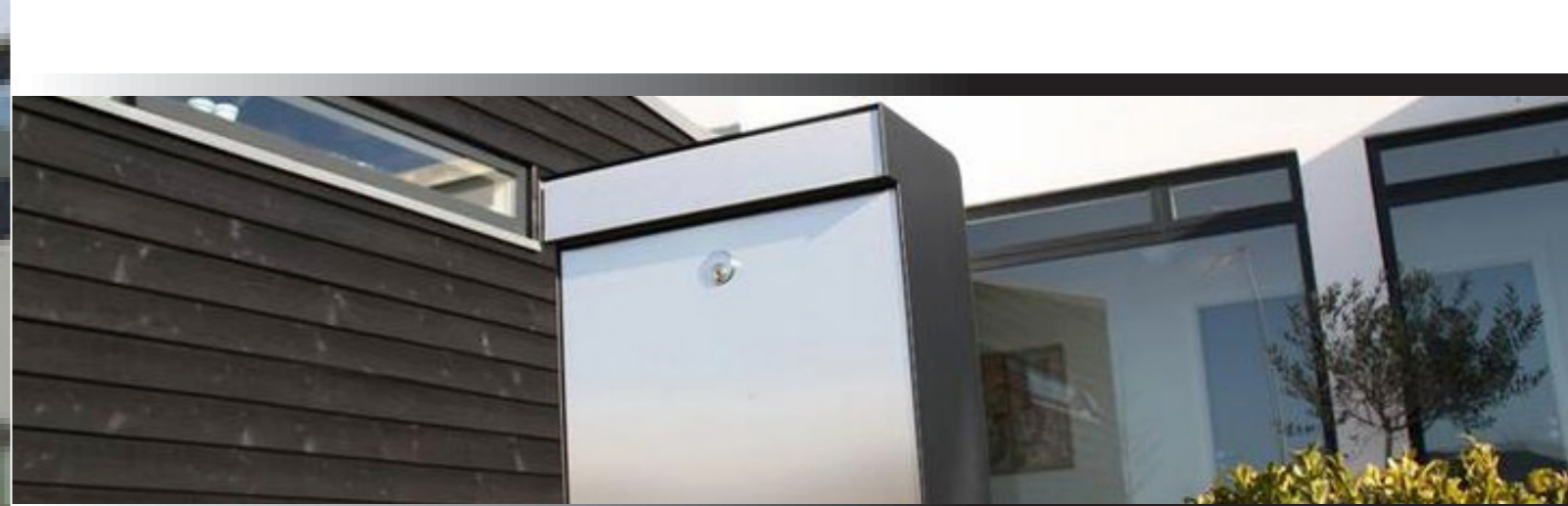

## ALLUX BY GARRISON RANGE

Garrison's new range of mailboxes are designed to be both modern and functional. Each design incorporates a solid structure and exceptional attention to detail, resulting in a product of high quality that lasts. Every mailbox in our new range comes with a 12 year warranty, your choice of labeling and the choice of two stand styles.

## CLASSIC SERIES

### Classic LT

The Classic LT is a clean, sturdy unit that exudes an aesthetically pleasing, classic design. The Classic LT can be used as a single unit or combined into a bank. Available in black or white, galvanized or painted steel.

- 1mm galvanized or painted steel
- Spring loaded retrieval slot

### Classic XL

The Classic XL, the LT's big brother, follows on with the clean solid, classic design. The Classic XL can also be used as a single unit or combined into a bank. Available in black painted galvanized steel with stainless steel front door and slot.

- 1mm galvanized or painted steel
- Spring loaded retrieval slot

## FRONTIER SERIES

The Frontier mailbox incorporates a striking design at half the price, without sacrificing quality. Projection and overhang form the characteristic shape that also protects your mail from the elements. Available in galvanized painted steel in black, white, red, and stainless steel.

- 440mm (h) x 345mm (w) x 180mm (d)

## ECLIPSE SERIES

### Eclipse

The Eclipse is an elegant, high quality product with a striking appearance. Ideal for individual or banked setups. Eclipse features a two part interior, the rear section holds newspaper and catalogues, while the secure front compartment hold your important mail.

### Eclipse LX

The Eclipse LX features a similar design to the standard Eclipse, with harder edges and a modern design. There is room for both the post and large quantities of newspapers/advertising you receive. Constructed of

strong materials, perfect as a single unit or banked.

## GALAXY PARCEL SERIES

With more and more people shopping online there is always the issue of what happens to your parcel if you're not available to receive it. The Galaxy Parcel Mailbox solves this problem with its generous capacity and secure delivery system. Perfect as a standalone mailbox, or a companion to your existing mailbox, you will never miss an important delivery again.

- Powdercoated steel available in black, grey, and white
- 1130mm (h) x 390mm (w) x 280mm (d)

## STANDS







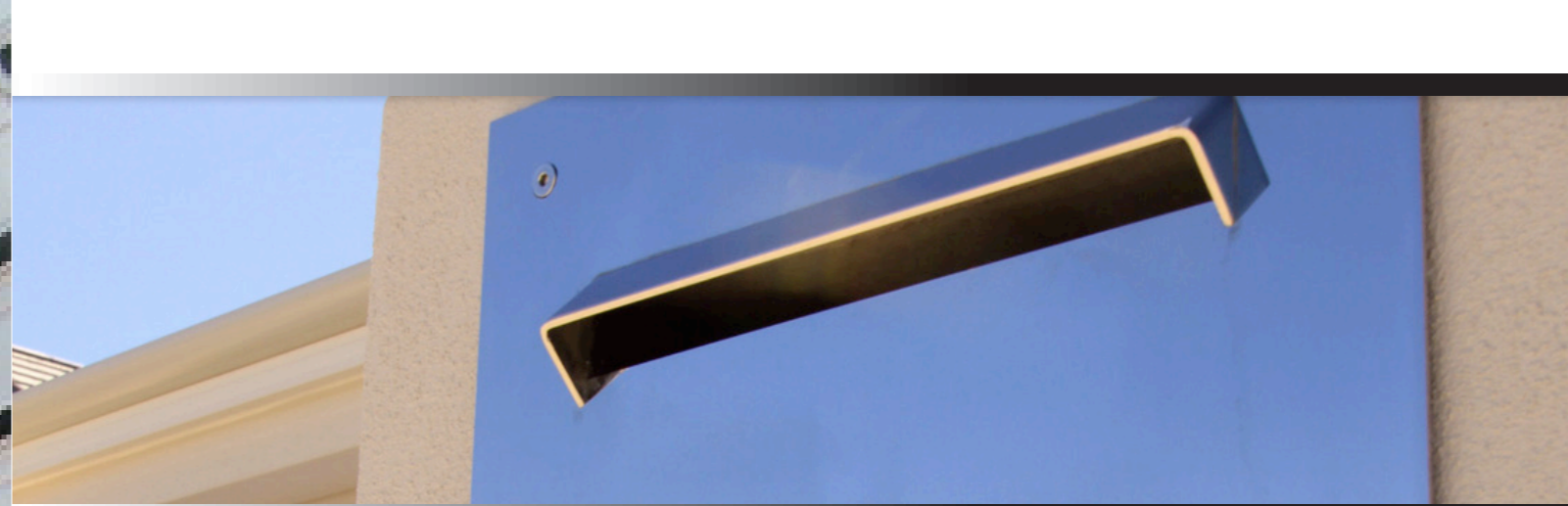

## SPECIFICATIONS

## FAQ'S

### Lead Time

Individual mailboxes from the Mailsafe and Tyro range are generally held in stock at our office. For large quantities and mailbox banks we advise a lead time of approx. 10 - 15 days may be required, depending on the finish type and other specifics. Small items such as locks and freestanding mailbox legs are available from our office also.

### Installation

We offer a complete solution from purchase to delivery and installation (if required). All our products are available for on site installation within Perth and surrounding areas. Feel free to contact us regarding your install. One of Garrison Solutions installation teams will contact you to arrange an appropriate installation date and time. It may be required for the client to be on site, depending on the specifics of the job.

### Key Replacement

On each mailbox lock is a unique number, if you require a replacement key simply obtain this number and contact Prestige Lock Services on (08) 9524 5983. They will be more than happy to help you with the replacement.

### Are Garrison Solutions mailboxes Rust Free?

Yes, both anodize and powder coat protect the mailbox from rust.

## LOGO KEY

### What do the logos mean?

- PC Powder coated finish
- SS Stainless steel finish and/or construction
- AN Clear anodised finish
- CP Copper finish/construction
- 316 316 stainless construction

- A4 Accepts A4 mail
- A3 Accepts A3 mail
- AP Australia Post recommended mailboxes

- ST Held in stock
- 5 5 working day lead time
- 10 10 working day lead time
- 15 15 working day lead time





## COLOUR CHART

Available powder coat finishes for our MailSafe range of products. Additional finishes may be available on request. Non-standard colours are available on request for an additional charge.

**Key** Gloss (G) / Satin (S) / Matt (M)

Pearl White <sub>G</sub>	Clay Pot <sub>S</sub>	Anotec Dark Grey <sub>M</sub>
White Birch <sub>G</sub>	Hunter Red <sub>S</sub>	Precious Onyx Pearl <sub>G</sub>
Shoji White <sub>S</sub>	Manor Red <sub>S</sub>	Charcoal <sub>G</sub>
Magnolia <sub>G</sub>	Jasper <sub>S</sub>	Black Satin <sub>S</sub>
Classic Cream <sub>S</sub>	Precious Bronze Pearl <sub>S</sub>	
Primrose <sub>G</sub>	New Hamersley Brown <sub>S</sub>	
Paperbark <sub>S</sub>	Surfmist <sub>S</sub>	
Stone Beige <sub>M</sub>	Shale Grey <sub>S</sub>	
Pale Eucalypt <sub>M</sub>	Anotec Silver Grey <sub>M</sub>	
Cottage Green <sub>S</sub>	Precious Silver Kinetic <sub>S</sub>	
Classic Hawthorn Green <sub>G</sub>	Dune <sub>S</sub>	
Pommel Blue <sub>G</sub>	Notre Dame <sub>G</sub>	
Deep Ocean <sub>S</sub>	Woodland Grey <sub>S</sub>	

## MAILSAFE BANK DIMENSIONS

DIMENSIONS AND CONFIGURATIONS CHART - ALL RANGES

TOTAL HEIGHT (mm)										No. of Rows	Total Number of Mailboxes															No. of Columns														
1216	1084	952	820	688	556	424	292	160	S7		9	8	7	6	5	4	3	2	1	1	2	3	4	5	6		7	8	9	10	11	12	13	14	15					
1216	1084	952	820	688	556	424	292	160	S7	9	8	7	6	5	4	3	2	1	1	2	3	4	5	6	7	8	9	10	11	12	13	14	15							
										MSF2	MSF3	MSF2C	MSF3C	MSF4	APR2	APR3	S7	S7L	334	674	1014	1354	1694	2034	2374	2714	3054	3394	3734	4074	N/A	N/A	N/A	3394	3734	4074	N/A	N/A	N/A	
																			234	474	714	954	1194	1434	1674	1914	2154	2394	2634	2874	3114	3354	3594	2394	2634	2874	3114	3354	3594	
																			114	234	354	474	594	714	834	954	1074	1194	1314	1434	N/A	N/A	N/A	1194	1314	1434	N/A	N/A	N/A	
																			334	674	1014	1354	1694	2034	2374	2714	3054	3394	3734	4074	N/A	N/A	N/A	3394	3734	4074	N/A	N/A	N/A	
																			370	712	1054	1396	1738	2080	2422	2764	3106	3448	3790	4132	N/A	N/A	N/A	3448	3790	4132	N/A	N/A	N/A	
																			270	512	754	996	1238	1480	1722	1964	2206	2448	2690	2932	3174	3416	3658	2448	2690	2932	3174	3416	3658	
																			340	652	964	1276	1588	1900	2212	2524	2836	3148	3460	3772	4084	N/A	N/A	3148	3460	3772	4084	N/A	N/A	
																			370	712	1054	1396	1738	2080	2422	2764	3106	3448	3790	4132	N/A	N/A	N/A	3448	3790	4132	N/A	N/A	N/A	

### Example Project:

A project requiring 70 mailboxes in one bank would require 7 rows and 10 columns

MSF2 Total Dimensions: 1165mm High x 3394mm Wide x 244mm Deep  
 MSF3 Compact Total Dimensions: 1165mm High x 1194mm Wide x 334mm Deep  
 APR3 Total Dimensions: 1267mm High x 2448mm Wide x 350mm Deep  
 Series 7 Total Dimensions: 952mm High x 3148mm Wide x 210mm Deep

	EXTERNAL DEPTH (mm)	SINGLE BOX EXTERNAL DIMENSIONS (mm)
MSF2	244	Width = 334, Height = 175, Depth = 244
MSF3	334	Width = 234, Height = 175, Depth = 334
MSF2C	244	N/A
MSF3C	334	N/A
MSF4	334	Width = 334, Height = 175, Depth = 334
APR2	250	Width = 370, Height = 205, Depth = 250
APR3	350	Width = 270, Height = 205, Depth = 250
S7	210	Width = 340, Height = 160, Depth = 210
S7L	210	Width = 370, Height = 160, Depth = 210