

THANK YOU FOR PURCHASING A FINE U.S. MADE TOOL
PLEASE READ THESE INSTRUCTIONS TO GET YEARS OF SATISFACTION

The patented **ROTO-SPLIT®** strips #14, 12, 10 & 8 gauge BX & MC cable & cuts 3/8" trade size flex. The new patent pending **ROTO-SPLIT® RS-101AC & RS-101B** have exclusive **auto clamping**. The **RS-101AC** strips new **reduced diameter brands of MC cable**. The **ROTO-FLEX** cuts 1/2" to 3/4" trade size flex & strips large size BX & MC cable such as: AWG #2/3 & AWG #4/3. For larger cables & flex up to 1-1/2" trade size use our **ROTO-FLEX RF-170**.

RS-101

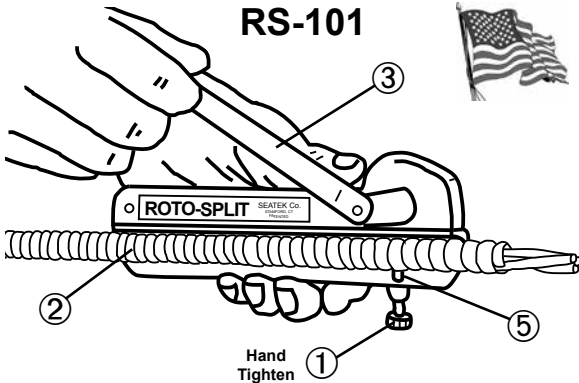

STEP 1 - ASSEMBLY

Remove the hex nut from the **curved handle** ③. Put the threaded screw into the blade shaft and push out the red plug. Screw on the hex nut with the counterbored side against the blade. Tighten the nut with an adjustable wrench.

STEP 2 - CABLE CLAMPING
RS-101 WITH THUMB NUT CLAMPING

Back-up **thumb screw** ① & insert **cable** ② into the channel. Hold **cable** ② in place with your thumb. Now turn **thumb screw** ① clockwise until the **tip of the clamping stud** ⑤ falls into the helical groove of the cable casing ②. Secure by hand tightening **thumb screw** ①. **Note: Do not tighten with pliers, only hand tightening is required to clamp the cable securely.**

RS-101A

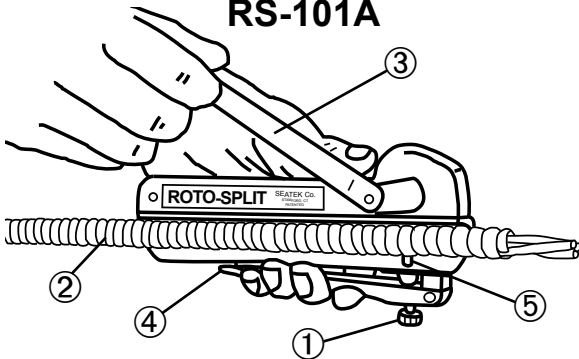

RS-101A, RS-101AL & RF-120A
WITH QUICK CLAMPING

Unscrew **knob** ① and insert **cable** ② into the channel. Squeeze **quick clamping lever** until the **clamping stud** ⑤ reaches the bottom of the cable groove. **The tip of the quick clamping lever** ④ should be just above the bottom of the tool. Adjust the depth of the **clamping stud** ⑤ by turning **knob** ① until the lever is in the correct position. **It is important to note that the cable should be clamped securely but not overtightened. Adjustment is normally not required when switching from #14 to #12 cables.** The quick clamping & release feature of the RS-101A makes it twice as fast as the original.

RS-101AC & B

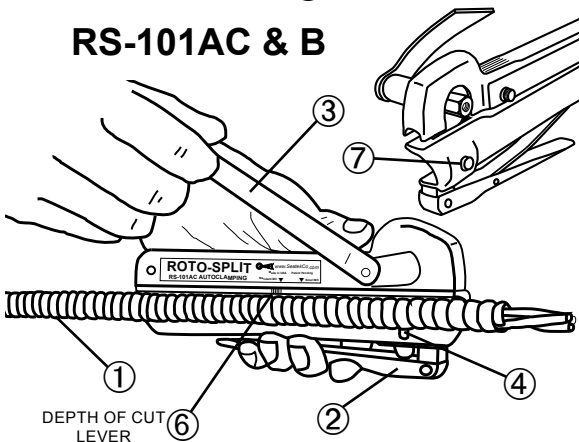

RS-101AC & RS-101B
WITH EXCLUSIVE AUTO CLAMPING

Insert **cable** ① into the channel and squeeze **auto-clamping lever** ② until the **clamping stud** ④ reaches the bottom of the cable groove. Hold the tool near the cutting head & squeeze the **RS-101AC or RS-101B** until the blade makes contact with the cable.

RS-101AC: For small diameter MC cable lever ⑥ must be in the forward position and button ⑦ must be pushed in completely (*flush with outer channel*) to properly position the cable.

STEP 3 - CUTTING MC CABLES

After the MC cable has been clamped, hold the tool near the cutting head and squeeze the **ROTO-SPLIT** or **ROTO-FLEX**. **Do not apply too much pressure** while pushing the "BLUE SAPPHIRE" circular blade against the cable. Rotate the **crank handle** ③ smoothly and change the amount of pressure to get the most efficient cutting action. When the **force required to turn the crank suddenly decreases, you have cut all the way through.** Release pressure and turn the crank slightly, the top should snap back to the original position.

WARNING!! Never attempt to cut already installed BX, MC or Flex cables on live lines, since any contact between a live wire and ground can be lethal.

STEP 4 - REMOVING THE ARMORED CASING

With our "BLUE SAPPHIRE" blade 2 to 5 brisk turns of the handle should be sufficient to split the BX casing. Hold the cable on each side of the cut and twist the armored casing counter-clockwise until it separates. If this last step fails, you have not cut all the way through the armor. Repeat the steps above.

STEP 5 - DEPTH OF CUT ADJUSTMENT

If the Roto-Split does not completely cut through the armor it may be required to **adjust the depth of cut**. Turn the set screw in the top housing **counter-clockwise a 1/4 turn** (use a 3/32 Allen wrench). Make a trial cut and adjust the set screw until the casing separates. **It is critical to check that the blade does not nick a wire after adjusting the depth of cut. Make a trial cut to test.** Casing can be separated by inserting the tip of a screwdriver blade into the slot and twisting to crack it open, or simply bend the cable slightly at the cut to snap the armored casing.

CUTTING LARGE MC AND FLEX

For large MC, BX and Flex use the **ROTO-FLEX RF-120 or RF-170**. The RF-120 cuts MC from AWG 4-4 up to 2-4 and Flex from 1/2" to 3/4". The RF-170 is our largest capacity hand tool and cuts MC from AWG 4-4 up to 4/0 and Flex from 1/2" to 1-1/2".

CUTTING REDUCED SIZE MC CABLE

Use the **Roto-Split RS-101AC** to cut reduced diameter MC cable such as Southwire MC^{AP}. Since this cable requires a reduced depth of cut slide the **lever ⑥** towards the front of the tool. Make sure **button ⑦ is pushed in completely (flush with outer channel) to center the cable on the blade**. Cut the cable armor as detailed in Step ③. To cut standard MC return **lever ⑥** to the rear position.

Warning: When cutting reduced wall MC the lever must be set forward to prevent possible damage to conductors

WARRANTY: All the ROTO-SPLIT and ROTO-FLEX models have a lifetime guaranty except for the blade. They are warranted to be free from defects in workmanship and material. Should any part of these tools be defective, they will be serviced or replaced free of charge (except for replacement blade). This warranty is void if these tools have been damaged by accident or mishandling. **THIS WARRANTY IS IN LIEU OF ALL OTHER WARRANTIES EXPRESS OR IMPLIED**, except for repair or replacement of parts. Seatek Company assumes no liability for damage to the replacement blade or other damages.

OUR TOOLS AND
BLADES ARE 100%
MADE IN THE USA

BLADE STORAGE CARTRIDGE
(SNAPS IN KNOB - STORES 6 BLADES)

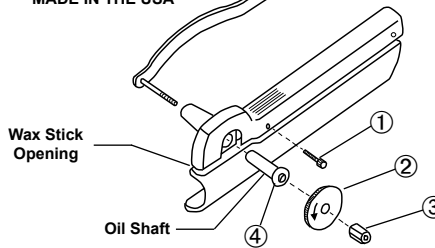

For maximum blade life lubricate the B-102 blade with LS-105 lubricant stick

B-102 blades are lubricated
DO NOT REMOVE WAX BEFORE USE

BLADE REPLACEMENT

Remove knurled screw ①. Using an adjustable wrench, remove nut ③. Swing up the top housing & push the handle assembly back about 1/2" inch. Lift out the blade ② & replace with a new blade, making sure that the arrow and logos are on top. Replace hex nut ③ & knurled screw ①. Please note that only a slight tightening of nut ③ is necessary since the nut will automatically secure during the first cut.

Note: Always oil the ④ blade shaft & thumb screw when blade is replaced

BLADE LUBRICATION

Use our **Lubricant Stick LS-105** for longer blade life and to prevent blade clogging (*not for use on aluminum*). Lubricant sticks are available from your local distributor. **NOTE:** our armored cable cutters have an opening in front to apply the lubricant stick, simply rotate the handle with the LS-105 inserted into the tool.

FOR LEFT HANDED USERS: No problem! Hold the Roto-Split upside down in your right hand & turn the crank clockwise with your left.

BLADE STORAGE

All our Roto-Split and Roto-Flex models (*except the RS-101*) have a blade storage cartridge contained in the knob. To release the cartridge simply pop it out with the tip of a screwdriver. Place your spare blades inside (up to a maximum of six) and snap the cartridge back into the knob. For best results always use genuine "BLUE SAPPHIRE" Cat. B-102 or B-107 blades.

| | | | | | |
|--|-------------------|--|---|---------------------------|---|
|  | B-102 | BLUE SAPPHIRE REPLACEMENT BLADE. USE ON: RS-101, RS-101A, RS-101AC, RF-120A, RF-120B & RF-170. |  | LS-105 | USE ON BLADES FOR ROTO-SPLIT & ROTO-FLEX & ROTOMATIC MODELS. (NOTE: DO NOT USE WHEN CUTTING ALUMINUM ARMOR) |
| | B-107 | BLADE WITH OFFSET TEETH FOR ALUMINUM OR STEEL CASING ON 1/2" FLEX & LARGER. NOT FOR RS-101AC |  | HARDWARE RETROFIT 101-106 | SPARE PARTS KIT FOR ROTO-SPLIT & ROTO-FLEX. CONTAINS ONE SHAFT, ONE HEX NUT, ONE 4-40 KNURLED SCREW, ONE RS-101 THUMBSCREW. |
| | B-108 | FOR ALL POWER TOOLS & MACHINES. RS-101-AP, RM-202A, B & C, RM-202M. | | | |
|  | POWER KIT 101-107 | POWER CONVERSION KIT. MOTORIZE ANY ROTO-SPLIT & ROTO-FLEX (SAME PRINCIPLE AS POWER-SPLIT). CONTAINS: B-108 BLADE, SHAFT, SCREW, WASHERS, HEX NUT & HEX WRENCH. |  | HANDLE 101-110 | HANDLE ASSEMBLY FOR ALL MODELS OF THE ROTO-SPLIT AND ROTO FLEX WITH BLADE CARTRIDGE STORED IN KNOB. |



A SMALL COMPANY WITH BIG IDEAS®

392 PACIFIC STREET, STAMFORD, CT 06902
PHONE 203-324-0067 ☆ FAX 203-324-7844 ☆ www.SeatekCo.com

All brands and product names are trademarks or registered trademarks of their respective companies

