

s50 litterbin



Above, black painted s50 with gold decal.
Right, black painted s50 with silver decal.



description

Zintec steel body with galvanized steel base and top. Powder coated finish throughout. Restricted aperture for minimising domestic use. Omos patented ashtray. Front opening with concealed hinge and slam latch.

dimensions

Height 939mm, width 409mm, depth 409mm.
Capacity 75L.
Weight 46Kg.

options

Choice of colours.
Choice of decal.

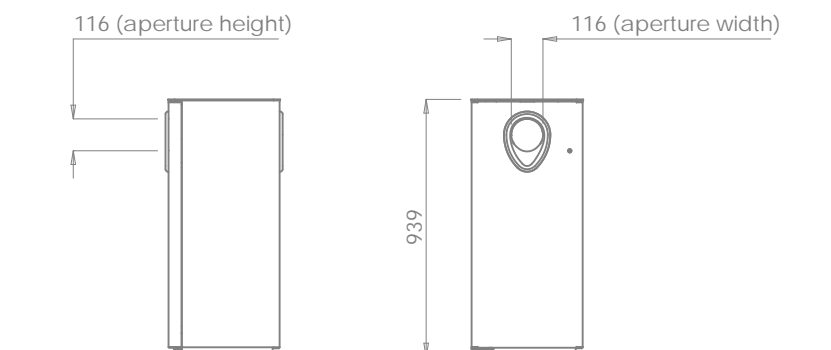
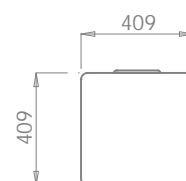

s50 Fixing Instructions

(for areas already paved)

- 1 Determine the location for the bin. Remove pavers and excavate a hole to minimum dimensions of L600 x W600 x D400mm. The size of the foundation may vary depending on the ground conditions.
- 2 Fill the hole with 35N20 concrete up to 15mm below the level of the underside of the pavers ensuring a good smooth surface finish.
- 3 Allow sufficient time for the concrete to set then apply a layer of dry sand/cement mix over the pad. Compact and adjust to bring this to the level of the underside of the paving.
- 4 Replace the paving slabs and ensure that they are well bedded in.
- 5 Place the bin in the desired location and mark through the fixing holes making sure this is done accurately.
- 6 Drill through pavers into the concrete pad. Drill following fixing manufacturer's instructions to suit the chosen fixing. Use M12 through bolts to fix (such as Hilti HSA M12 x 180).
- 7 Tighten the levelling base.
- 8 Lift the bin into place and tighten the nuts.

Foundations

The bin can be fixed directly to a concrete slab or to concrete pads beneath paving stones. Foundations must be to engineer's specification.

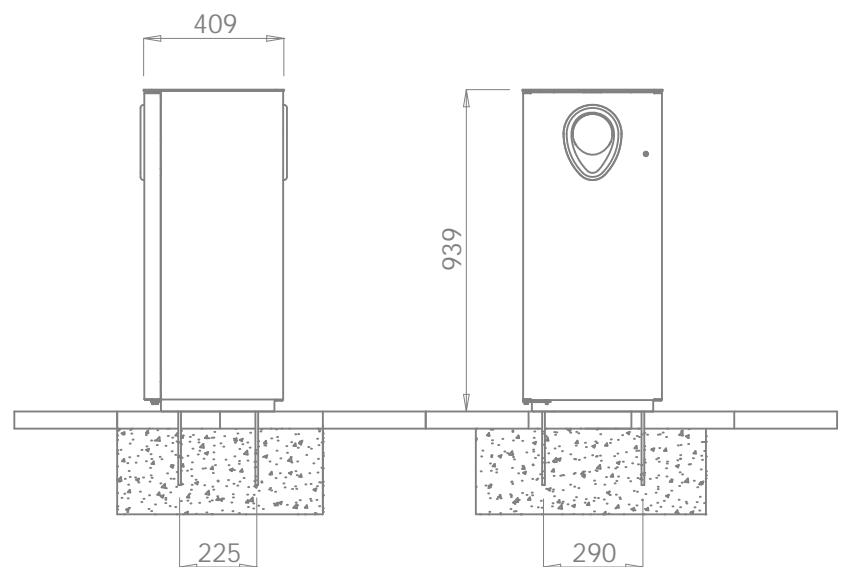
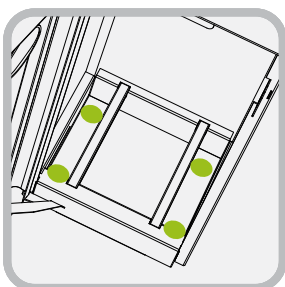
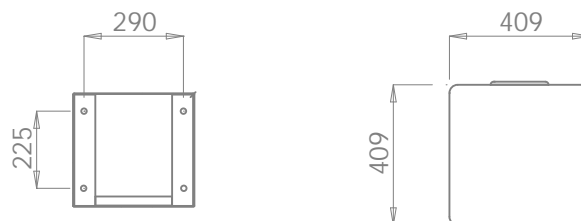

Right and above, fixing details.

s50 Care and Maintenance Guidelines

The s50 litterbin is constructed from zintec steel and galvanised mild steel with a formed ABS aperture. Despite the material's corrosion resistant properties some care is required to maintain a bright appearance.

The extent to which cleaning is required will depend on a number of factors including environmental conditions, construction activity and level of use.

Maintaining the painted galvanized steel

The s50 is finished in polyester powder, a plastic coating which is baked onto the components prior to assembly. This is a highly durable finish which will last for many years.

To maintain the original appearance of the metalwork it should be cleaned inside and out regularly using warm soapy water. Avoid the use of abrasive cleaners as they may damage the surface finish. Should the paint become chipped or scratched it can be touched up using acrylic based paint.

If the damage has penetrated the galvanized coating the area should be cleaned with a wire brush and a zinc rich primer should be applied prior to the top coat. For further advice contact Omos on + 353 45 899802.

Maintaining the ABS plastic aperture

To maintain the finish of the formed plastic aperture it should be cleaned regularly using warm soapy water. Avoid the use of abrasive cleaners as they may damage the surface finish.

Liner

The s50 litterbin is equipped with a 75L galvanized steel liner. To prolong the life of the liner Omos recommends using plastic bin liners. This will also prevent seepage of liquids onto the surrounding pavement.

Locks, hinges and other moving parts

All moving parts should be kept clean and lubricated to ensure a long life. A spray lubricant such as 'WD40' is widely available and well suited.



Right, painted silver s50 with black ABS aperture and black decal.