

3-in-1 NOMADsport

folding conference table | presentation board | ping pong table

scale^{1:1}



NOMAD Sport

Conference Table and Presentation Board

scale^{1:1}

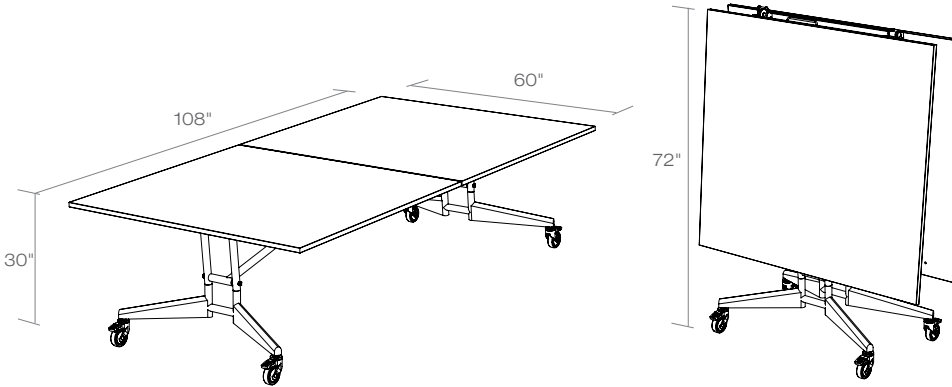

Desktop:

Durable laminate work surface with tough 2mm PVC edge banding for long lasting quality and protection against bumps and dents.

Base & Legs:

Built to last powder coated steel legs and folding frame on lockable casters. The NOMAD folds for storing and can be used as a presentation marker board.

Power/Data Modules:

See electrical power and data for details. Custom ports configurations available.



Mobile Markerboard

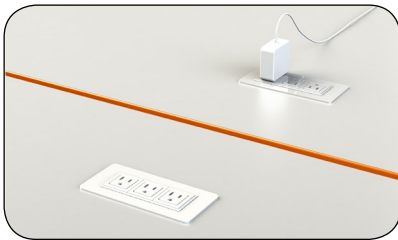

NOMAD Sport Power Kit

(Optional) Surface mounted power
Includes (2) 3 outlet power units
Jumper and Starter Cable Wall plug
(custom options available)



Ping-Pong Set Included

desktop finish & edge banding options

Laminate options:

White Matte	White Gloss	White Dry-Erase	Tangerine Dry-Erase	Scale Green Dry-Erase	Maple	Brasil Wood	Sandcastle

Edge Banding options:

White	Tangerine	Scale Green	Storm Gray	Maple	Brasil Wood	Sandcastle

ordering

SPRT ND

<input type="checkbox"/>	<input type="checkbox"/>		
Laminate		Edge Banding	
WM: White Matte	WG: White Gloss	W: White	TN: Tangerine
WDE: White Dry-Erase	MP: Maple	SG: Scale Green	SY: Storm Gray
BW: Brasil Wood	SC: Sandcastle	MP: Maple	BW: Brasil Wood
TN: Tangerine	SG: Scale Green	BW: Brasil Wood	SC: Sandcastle
		SC: Sandcastle	

