

8

7

6

5

4

3

2

1

F

E

D

C

B

A

F

E

D

C

B

A

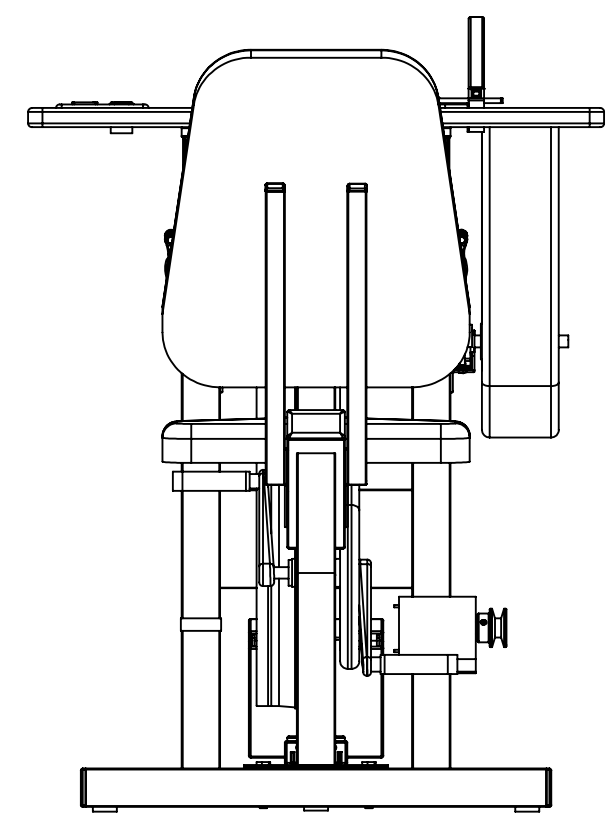
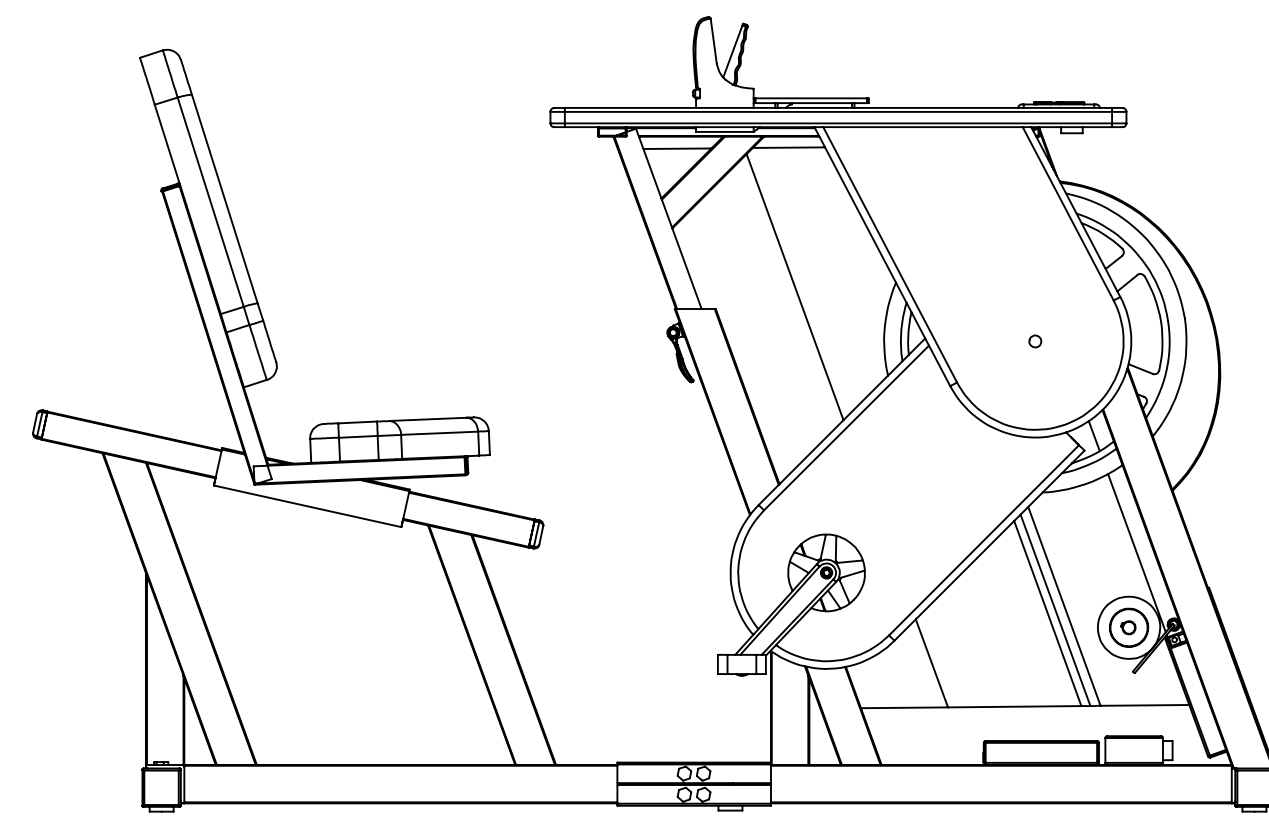
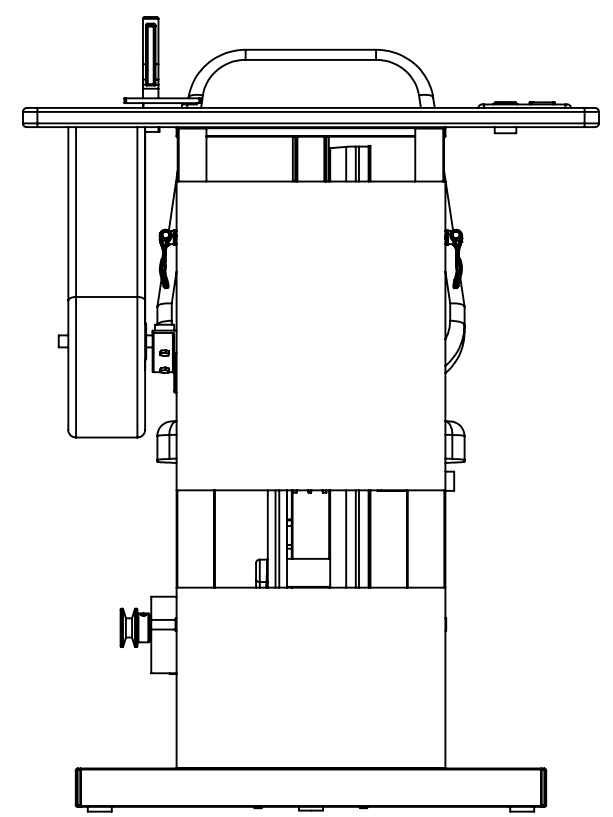
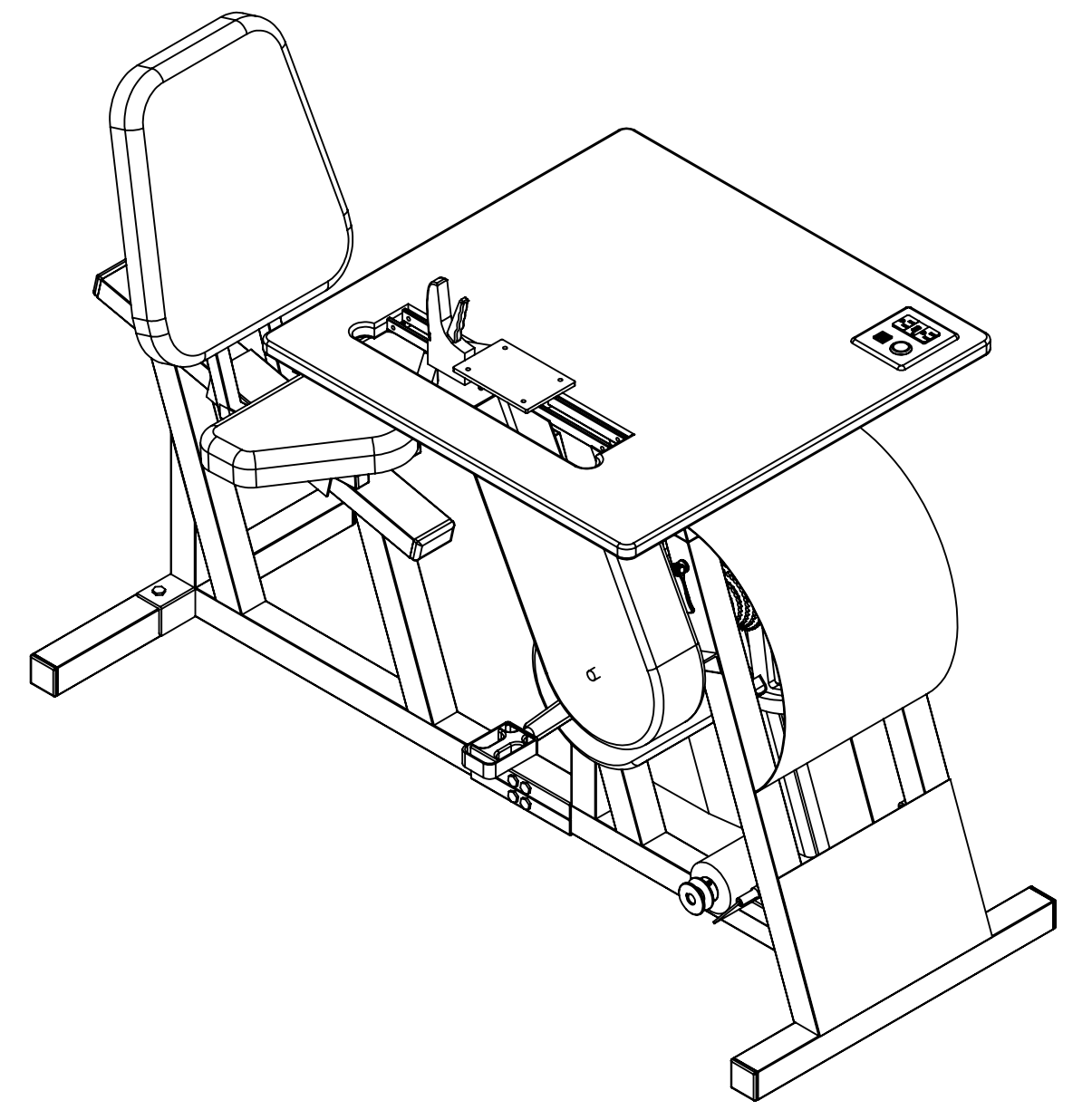
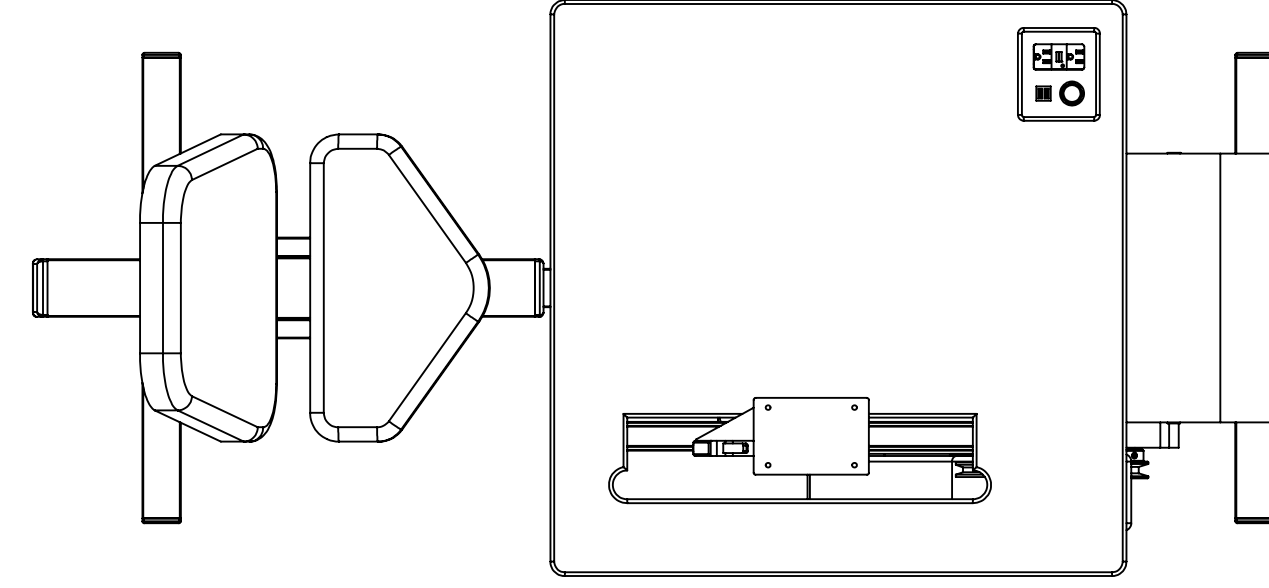
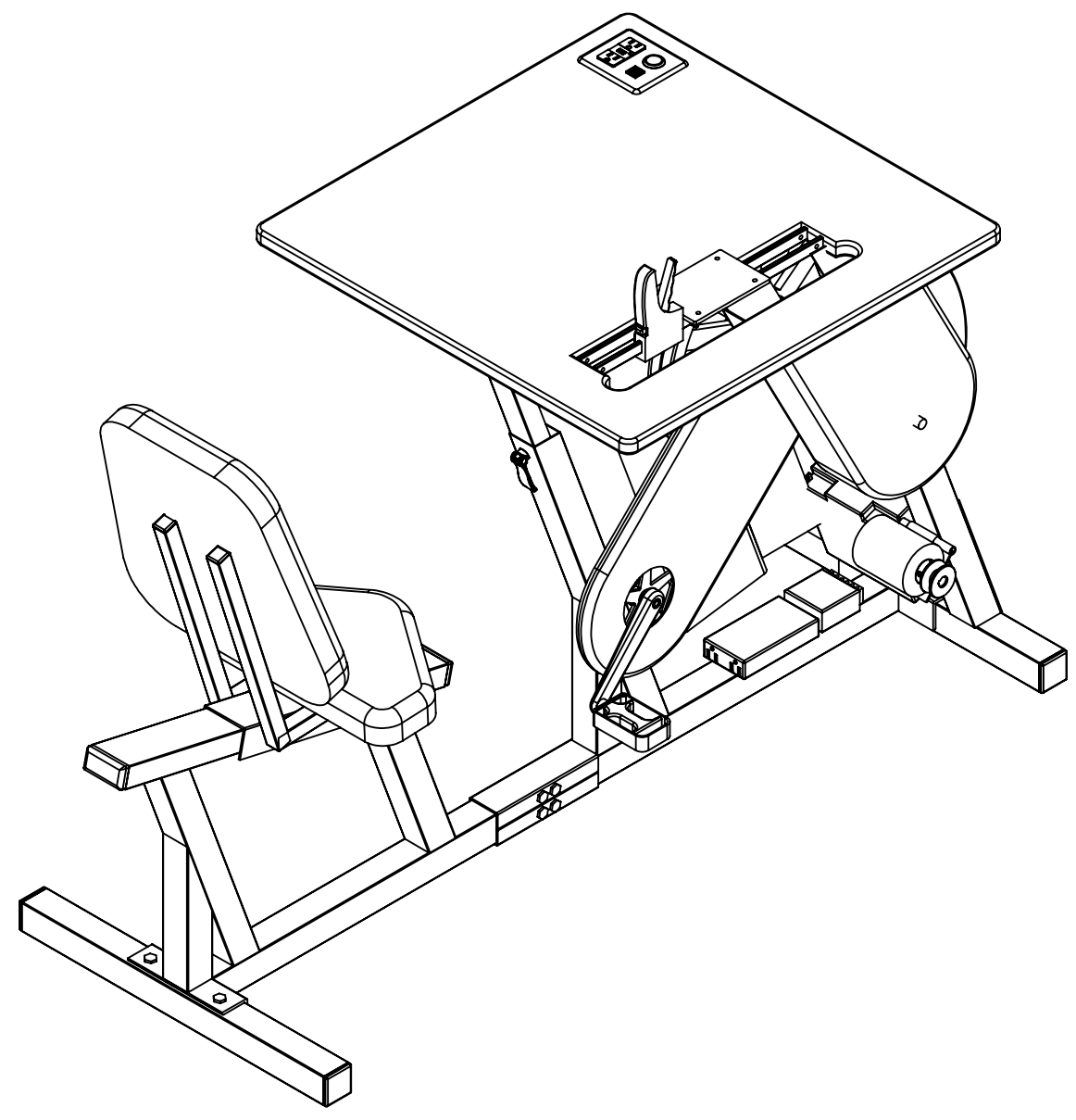

PROPRIETARY AND CONFIDENTIAL
 THE INFORMATION CONTAINED IN THIS DRAWING IS THE SOLE PROPERTY OF PEDAL POWER ENGINEERING, LLC. ANY REPRODUCTION IN PART OR AS A WHOLE WITHOUT THE WRITTEN PERMISSION OF PEDAL POWER ENGINEERING, LLC IS PROHIBITED.

		UNLESS OTHERWISE SPECIFIED:		DRAWN		NAME		DATE		Pedal Power Engineering	
		DIMENSIONS ARE IN INCHES		CHECKED						TITLE:	
		TOLERANCES:		ENG APPR.						RC1 Assembly	
		FRACTIONAL: ± 0.125		MFG APPR.						SIZE DWG. NO. REV	
		ANGULAR: MACH±1 BEND ±1		Q.A.						C	
		TWO PLACE DECIMAL ± 0.062		COMMENTS:						SCALE: 1:10 WEIGHT: SHEET 1 OF 1	
		THREE PLACE DECIMAL ± 0.03		Unit is mix of stock components, bar stock and sheet metal as noted.							
		INTERPRET GEOMETRIC TOLERANCING PER:		FINISH							
		MATERIAL		paint or brushed							
		various		DO NOT SCALE DRAWING							
NEXT ASSY		USED ON		APPLICATION							