

UNLESS OTHERWISE SPECIFIED:
 DIMENSIONS ARE IN MILLIMETERS
 SURFACE FINISH:
 TOLERANCES:
 LINEAR:
 ANGULAR:

FINISH:
 Sand smooth as noted

DEBUR AND
 BREAK SHARP
 EDGES

DO NOT SCALE DRAWING

REVISION 2

1x

NAME	SIGNATURE	DATE			
DRAWN	JRB				
CHK'D	JRB	6/24/2014			
APPV'D					
MFG					
Q.A					
			MATERIAL: Wood or Equivalent		
			WEIGHT:		

TITLE:
Inventory Faceplate

DWG NO.

0.3_PN001a

A4

SCALE:1:1

SHEET 1 OF 1

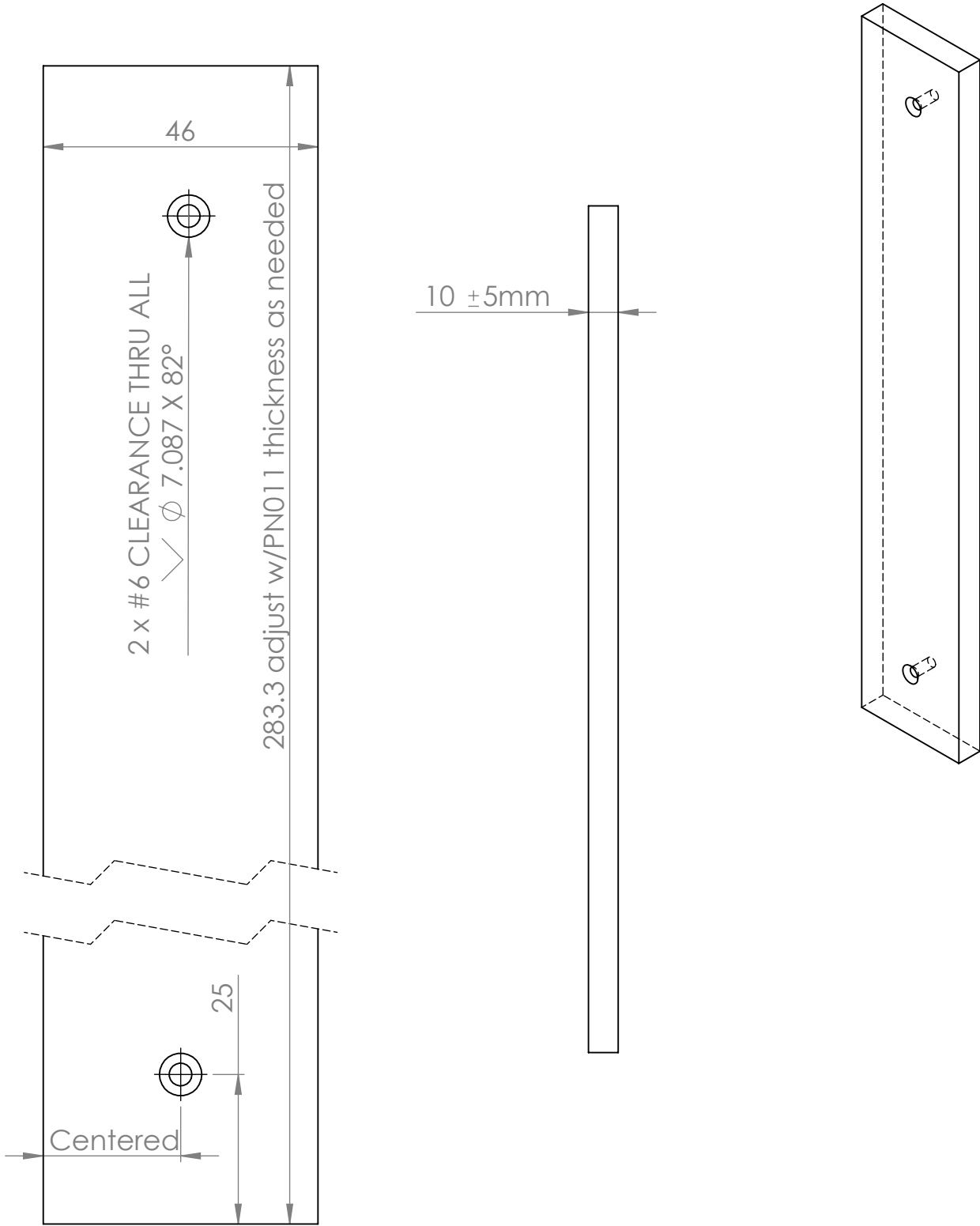

UNLESS OTHERWISE SPECIFIED:
 DIMENSIONS ARE IN MILLIMETERS
 SURFACE FINISH:
 TOLERANCES:
 LINEAR:
 ANGULAR:

FINISH:

Smooth

DEBUR AND
 BREAK SHARP
 EDGES

DO NOT SCALE DRAWING

REVISION

1

1x

	NAME	SIGNATURE	DATE		
DRAWN	JRB		6/17/14		
CHK'D	JRB		6/24/14		
APPV'D					
MFG					
Q.A				MATERIAL:	
				Wood or Equivalent	
				WEIGHT:	

TITLE:

Inventory Center Bar

DWG NO.

0.3_PN001b

A4

SCALE:1:1

SHEET 1 OF 1

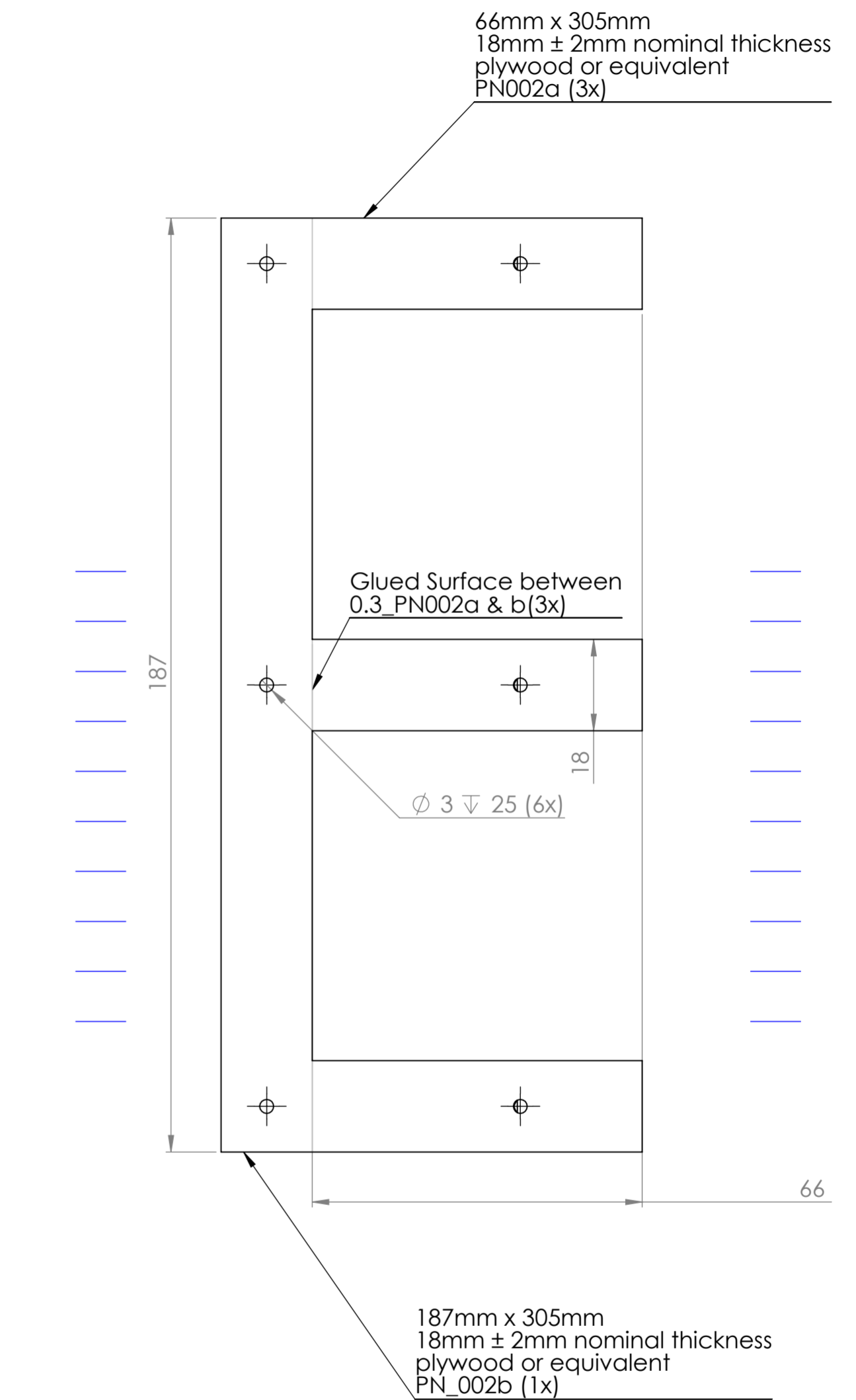
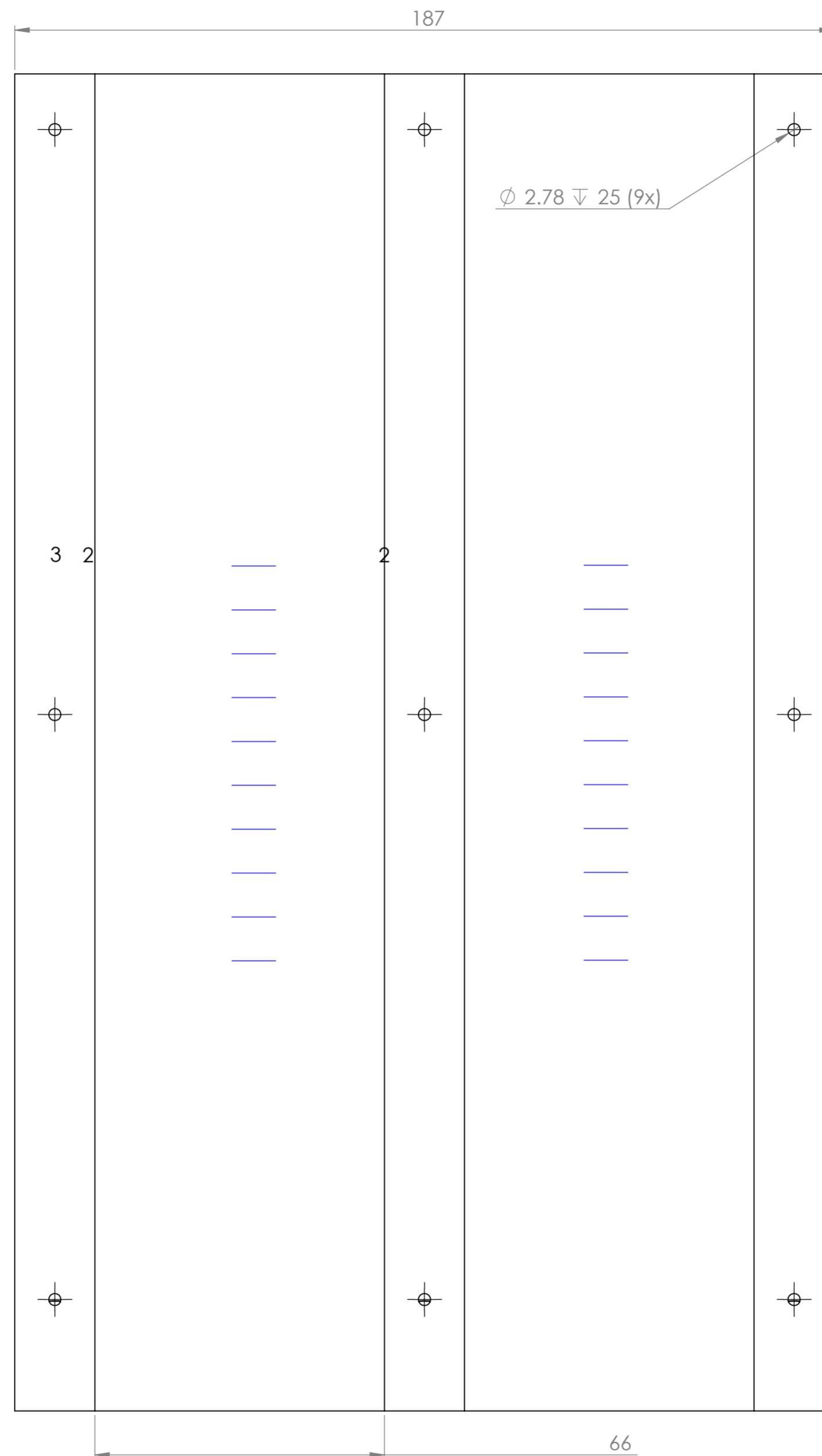
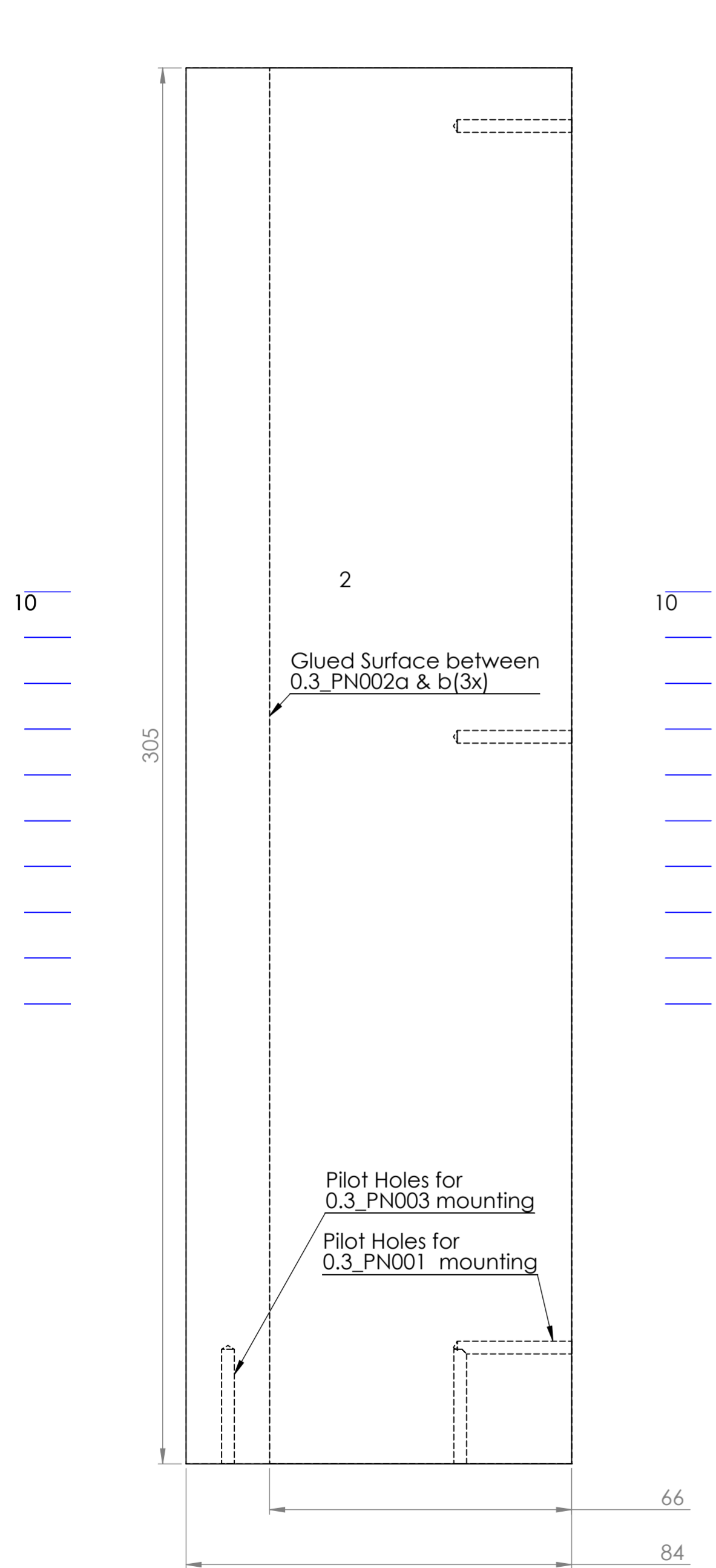

UNLESS OTHERWISE SPECIFIED: DIMENSIONS ARE IN MILLIMETERS				FINISH:		DEBUR AND BREAK SHARP EDGES		DO NOT SCALE DRAWING		REVISION	
SURFACE FINISH:											
TOLERANCES:											
LINEAR:											
ANGULAR:											
	NAME	SIGNATURE	DATE					TITLE:			
DRAWN								Inventory Chute			
CHKD											
APPVD											
MFG											
Q.A								MATERIAL:		DWG NO. 0.3_PN002a A2	
								WEIGHT:		SCALE:1:1 SHEET 1 OF 1	

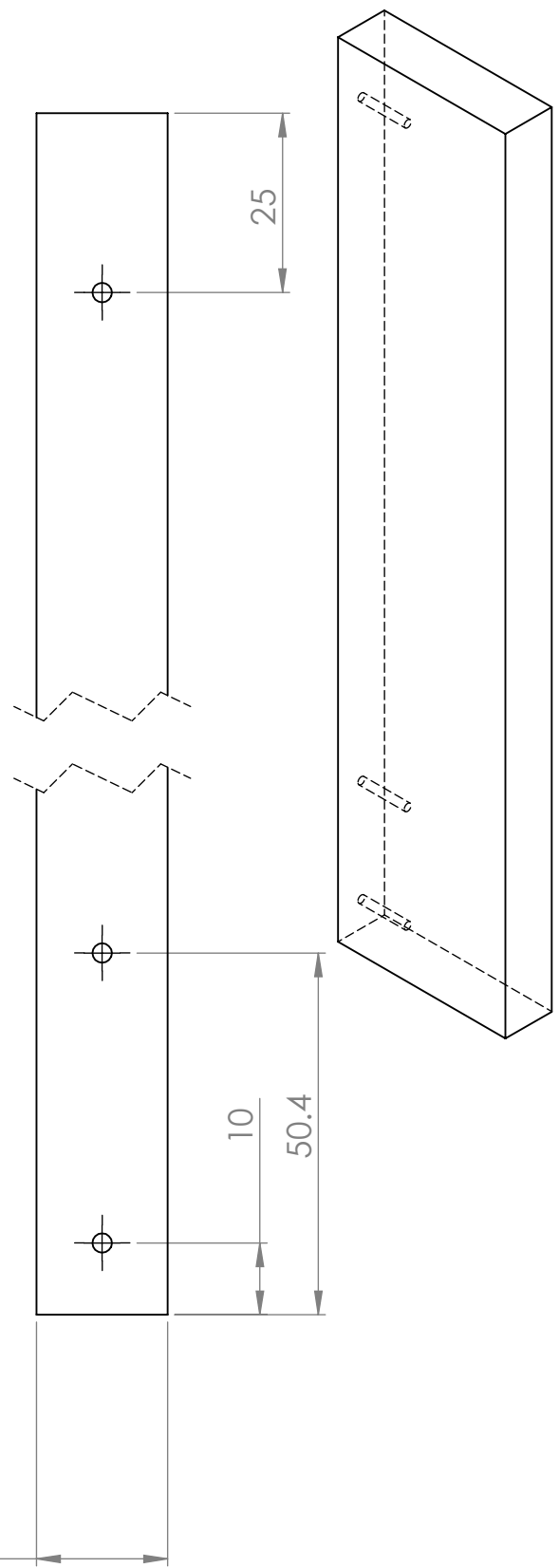
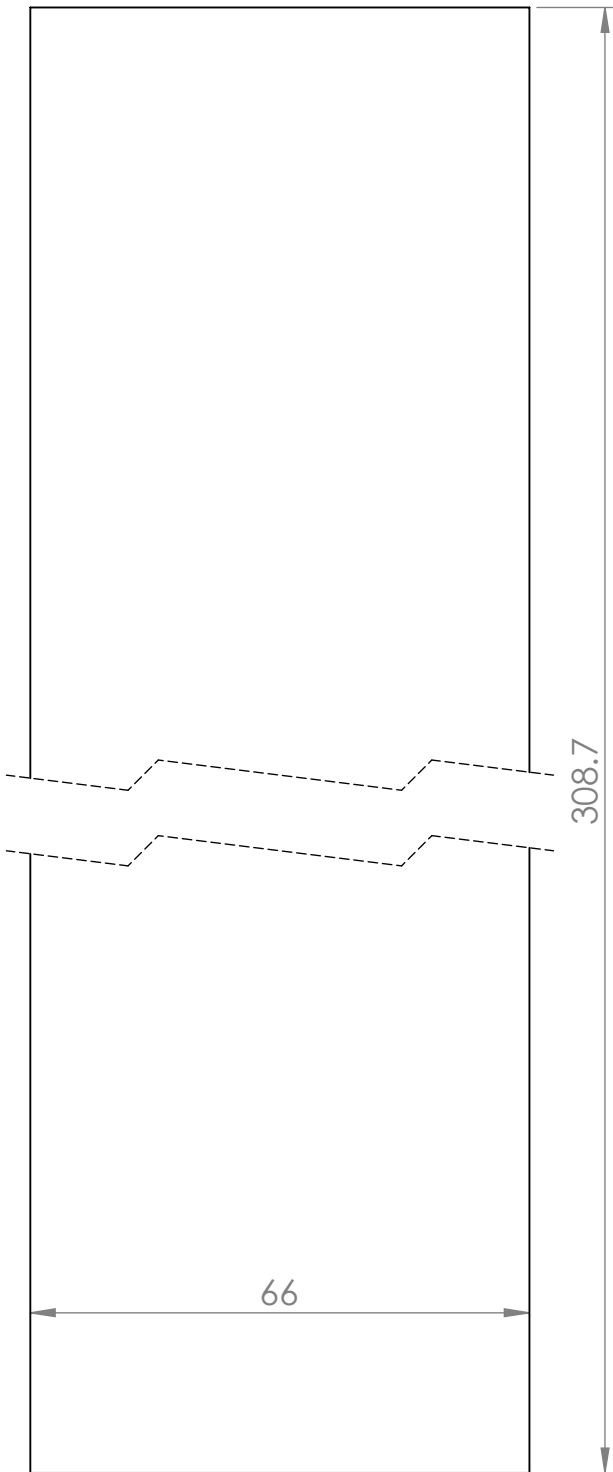

18.256 VARIABLE,
ADJUST FULL ASSY WIDTH AS NECESSARY

UNLESS OTHERWISE SPECIFIED: DIMENSIONS ARE IN MILLIMETERS SURFACE FINISH: TOLERANCES: LINEAR: ANGULAR:				FINISH: Sand Smooth		DEBUR AND BREAK SHARP EDGES		DO NOT SCALE DRAWING		REVISION 2	
								3x			
DRAWN JRB				SIGNATURE		DATE 06/24/14		TITLE: Inventory Chute			
CHK'D JRB								DWG NO. 0.3_PN002a			
APPV'D								A4			
MFG								SCALE:1:1			
Q.A						MATERIAL: Wood Or Equivalent		SHEET 1 OF 1			
						WEIGHT:					

Thickness designed for 17mm,
shim away from PN007 as necessary
to preserve alignment

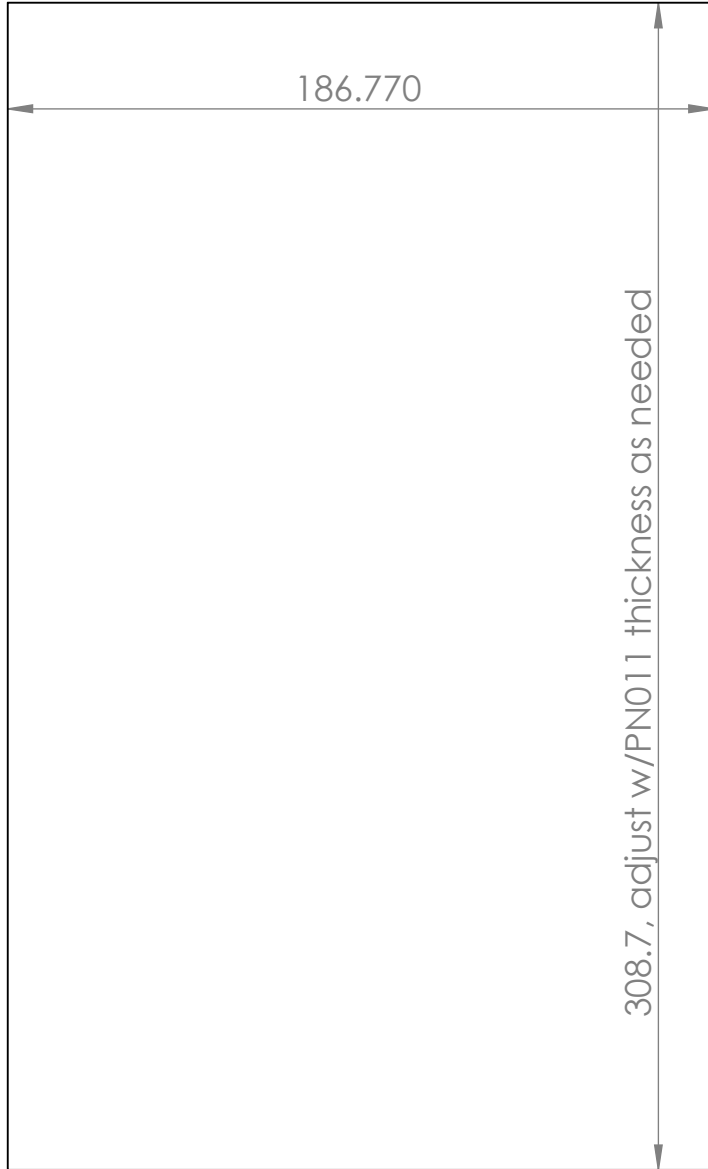
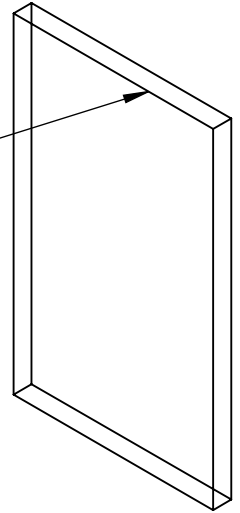

UNLESS OTHERWISE SPECIFIED:
DIMENSIONS ARE IN MILLIMETERS
SURFACE FINISH:
TOLERANCES:
LINEAR:
ANGULAR:

FINISH:

Sand smooth

DEBUR AND
BREAK SHARP
EDGES

DO NOT SCALE DRAWING

REVISION

2

1x

	NAME	SIGNATURE	DATE		
DRAWN	JRB		06/17/14		
CHK'D	JRB		06/24/14		
APPV'D					
MFG					
Q.A					
				MATERIAL:	
				Wood or equivalent	
				WEIGHT:	

TITLE:

Inventory Back

DWG NO.

0.3_PN002b

A4

SCALE:1:2

SHEET 1 OF 1

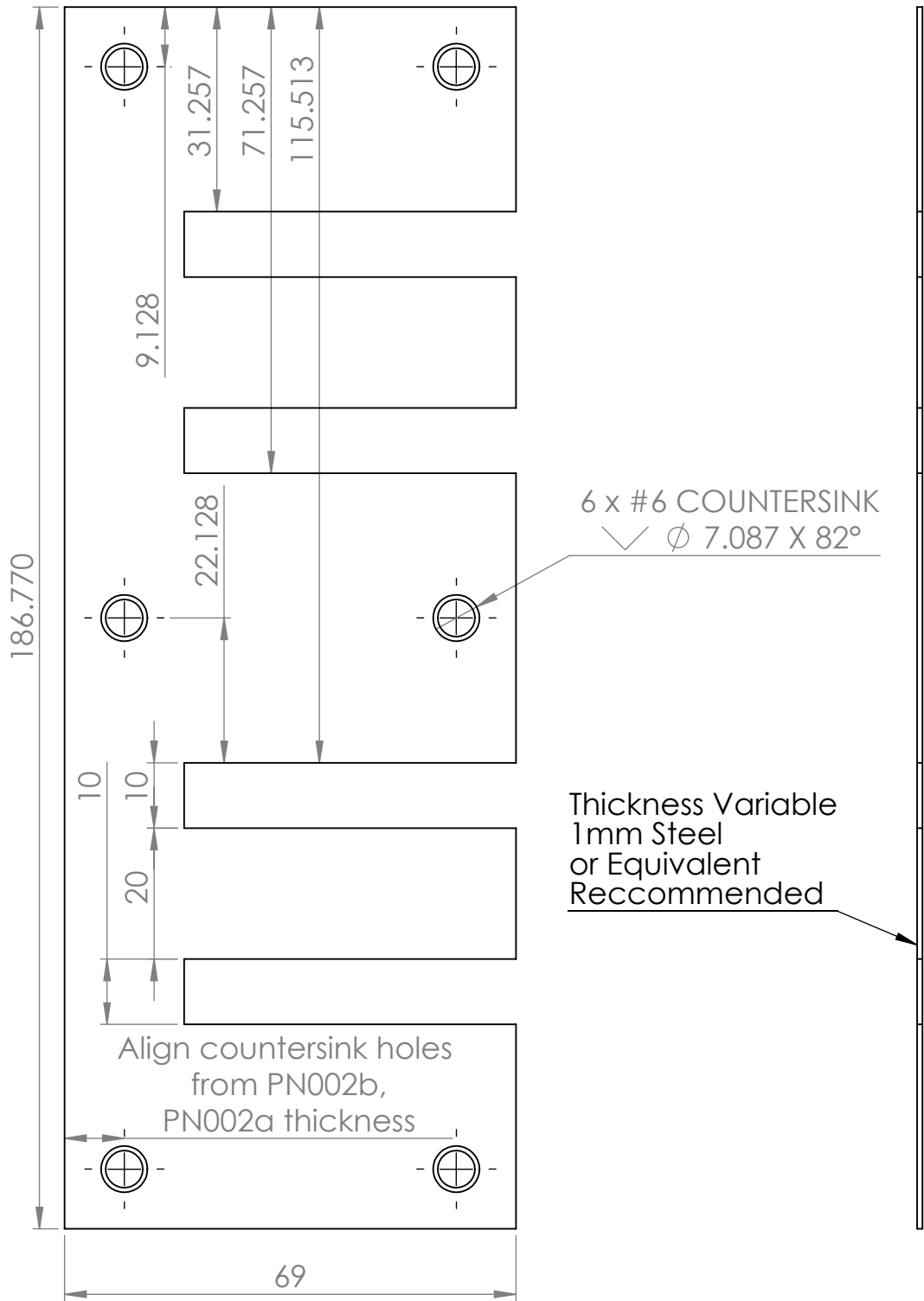

UNLESS OTHERWISE SPECIFIED:
 DIMENSIONS ARE IN MILLIMETERS
 SURFACE FINISH:
 TOLERANCES:
 LINEAR:
 ANGULAR:

FINISH:
 Debur, File

DEBUR AND
 BREAK SHARP
 EDGES

DO NOT SCALE DRAWING

REVISION 2

NAME	SIGNATURE	DATE
DRAWN JRB		06/17/14
CHK'D JRB		06/24/14
APPV'D		
MFG		
Q.A		
MATERIAL:		Steel
WEIGHT:		

TITLE:
Interface Plate

DWG NO. **0.3_PN003**

SCALE:1:1

SHEET 1 OF 1

A4

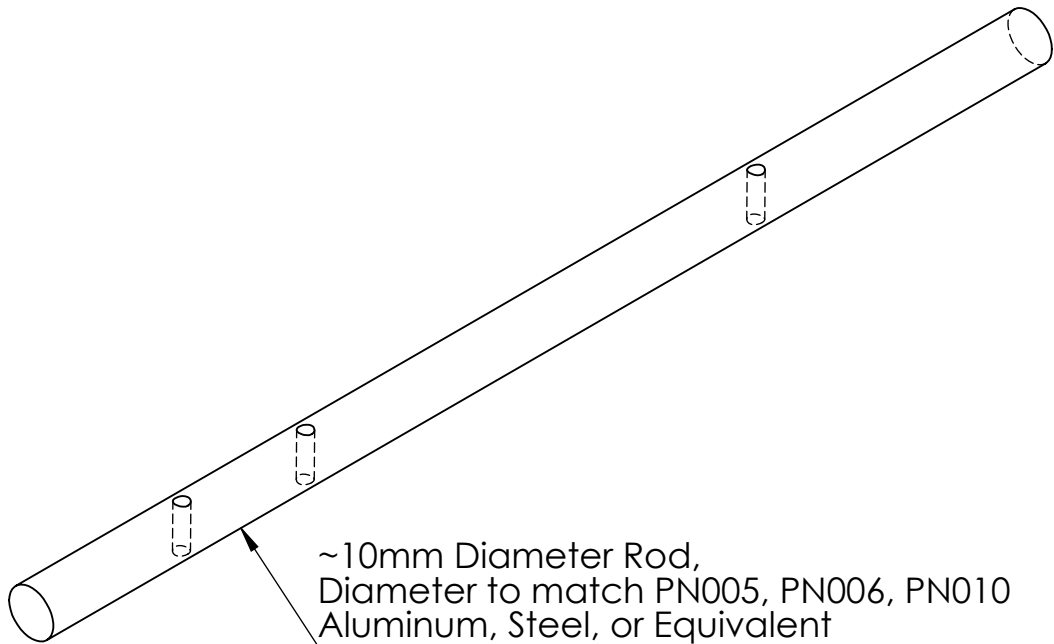
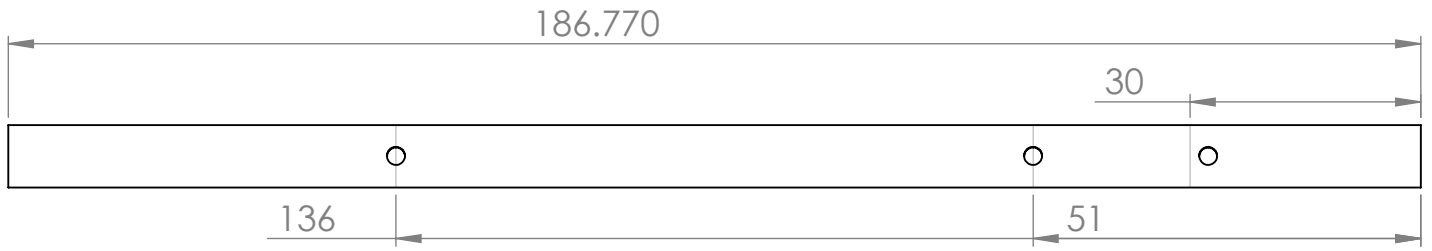

UNLESS OTHERWISE SPECIFIED: DIMENSIONS ARE IN MILLIMETERS SURFACE FINISH: TOLERANCES: LINEAR: ANGULAR:				FINISH: Smooth		DEBUR AND BREAK SHARP EDGES		DO NOT SCALE DRAWING		REVISION 3		
								1x				
								Axle				
DRAWN JRB 06/17/14				SIGNATURE				DATE 06/24/14		TITLE:		
CHK'D JRB 06/24/14										DWG NO. 0.3_PN004		A4
APPV'D												
MFG												
Q.A				MATERIAL: Aluminum/Steel								
				WEIGHT:				SCALE:1:2		SHEET 1 OF 1		

DETAIL A
SCALE 5 : 1

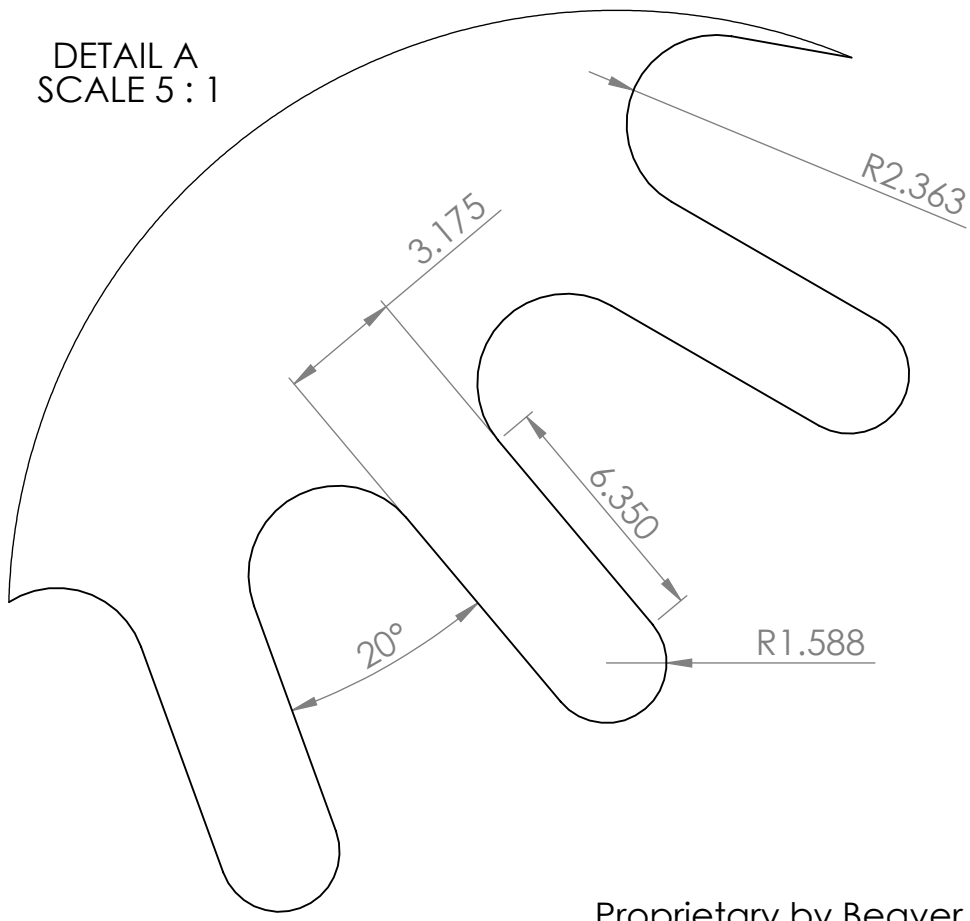

Proprietary by Beaver Coin Mechanism

I.D. matches PN004 O.D.

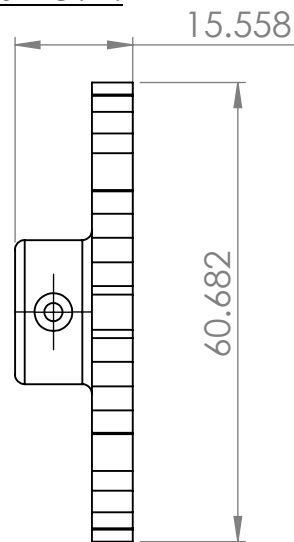
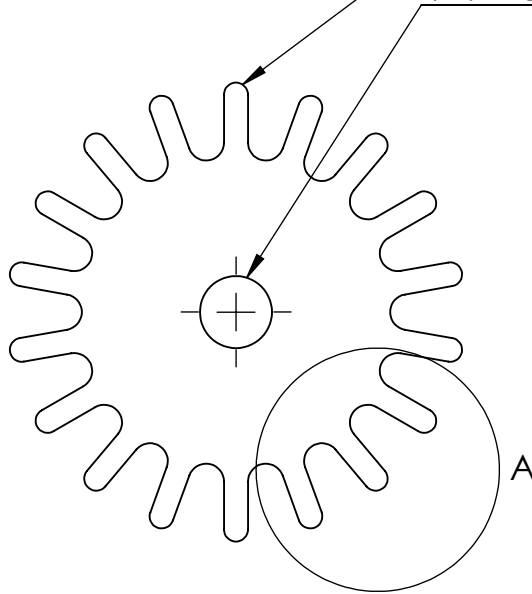

UNLESS OTHERWISE SPECIFIED:
DIMENSIONS ARE IN MILLIMETERS
SURFACE FINISH:
TOLERANCES:
LINEAR:
ANGULAR:

FINISH:

Smooth

DEBUR AND
BREAK SHARP
EDGES

DO NOT SCALE DRAWING

REVISION

1

1x

	NAME	SIGNATURE	DATE		
DRAWN	JRB		06/17/24		
CHK'D	JRB		06/24/14		
APPV'D					
MFG					
Q.A				MATERIAL:	
				Printed ABS	
				WEIGHT:	

TITLE:

Reduction Gear

DWG NO.

0.3_PN005

A4

SCALE:1:1

SHEET 1 OF 1

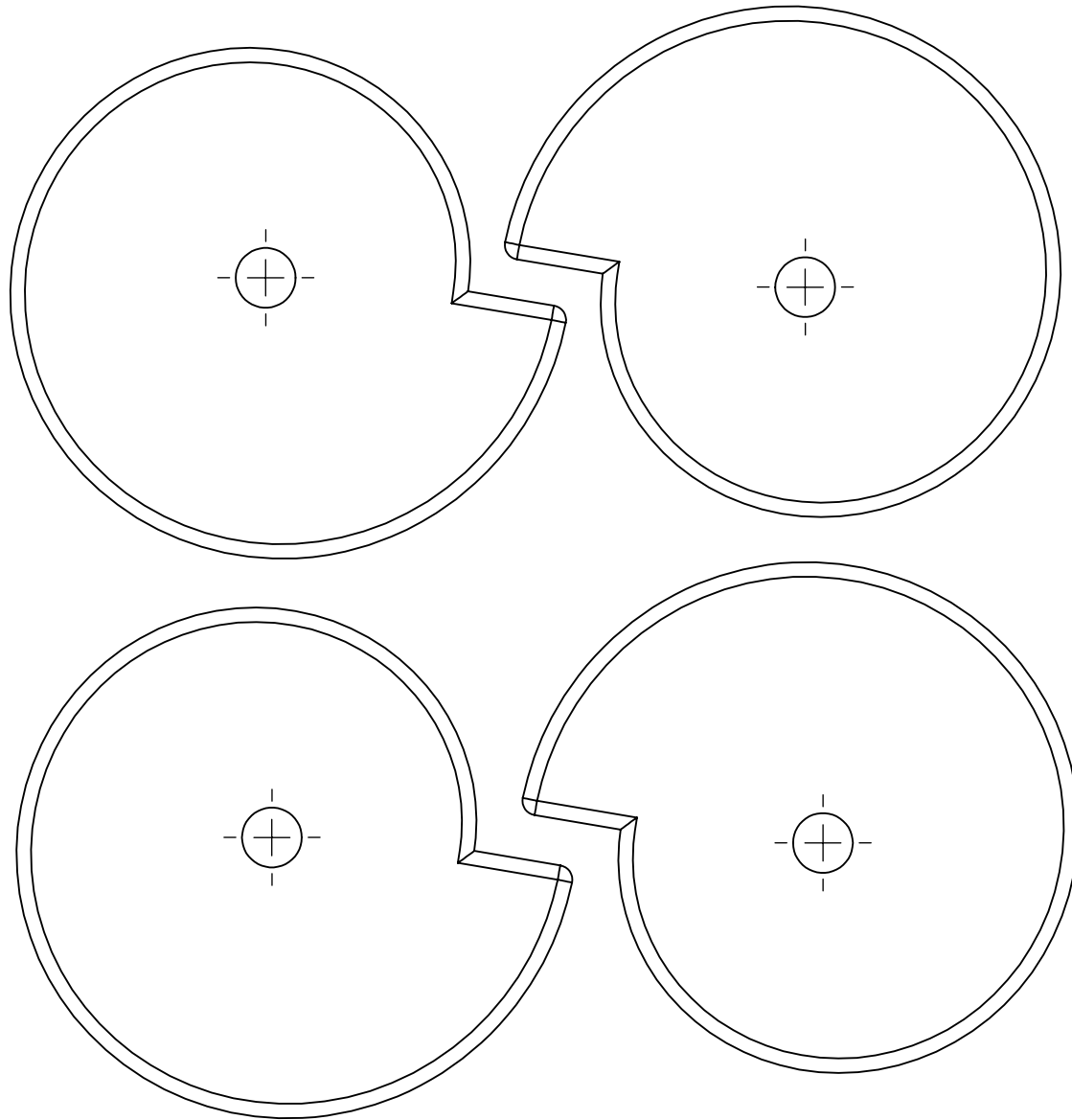

UNLESS OTHERWISE SPECIFIED:
 DIMENSIONS ARE IN MILLIMETERS
 SURFACE FINISH:
 TOLERANCES:
 LINEAR:
 ANGULAR:

FINISH:

DEBUR AND
 BREAK SHARP
 EDGES

DO NOT SCALE DRAWING

REVISION

	NAME	SIGNATURE	DATE		
DRAWN					
CHK'D					
APPV'D					
MFG					
Q.A				MATERIAL:	
				WEIGHT:	

TITLE:	<h1>Cam</h1>	
DWG NO:	<h2>0.3_PN006 Template^{A4}</h2>	
SCALE:1:1	SHEET 1 OF 1	

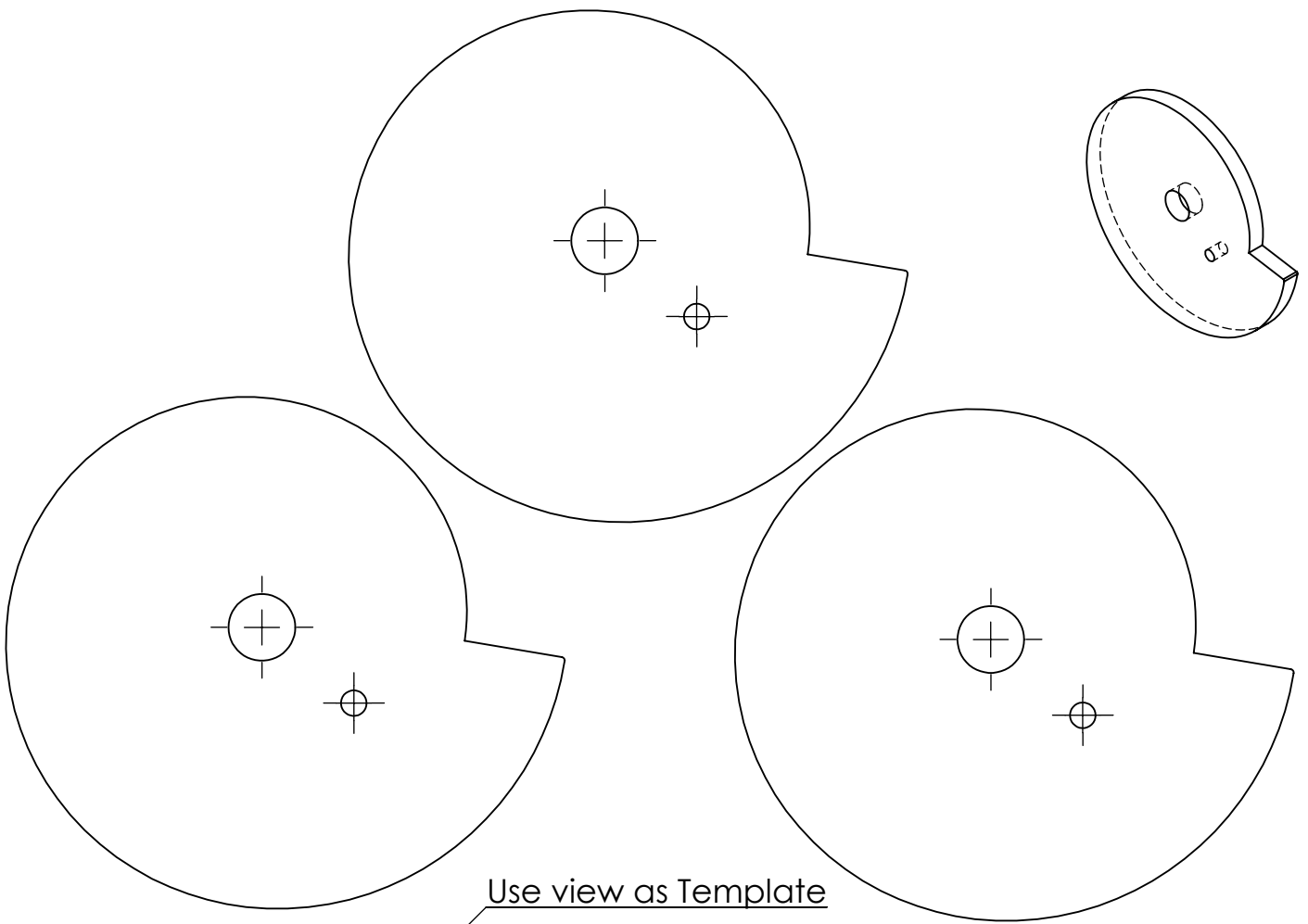

Use view as Template

Parametric Equation:
 $x = 28\cos(12.5t)$
 $y = 28\sin(12.5t)$
 Where $1.0 < t < 1.5$
 t measured in mm

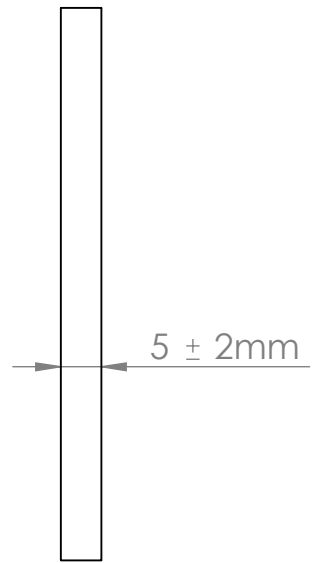

I.D. to match PN004 O.D.

UNLESS OTHERWISE SPECIFIED:
 DIMENSIONS ARE IN MILLIMETERS
 SURFACE FINISH:
 TOLERANCES:
 LINEAR:
 ANGULAR:

FINISH:

Smooth,
 Do Not Radius Sharp Corners

DEBUR AND
 BREAK SHARP
 EDGES

DO NOT SCALE DRAWING

REVISION

1

4x

	NAME	SIGNATURE	DATE		
DRAWN	JRB		06/17/14		
CHK'D	JRB		06/24/14		
APPV'D					
MFG					
Q.A					
				MATERIAL:	
				Wood/Plastic/Equiv.	
				WEIGHT:	

TITLE:

Cam

DWG NO.

0.3_PN006

A4

SCALE:1:1

SHEET 1 OF 1

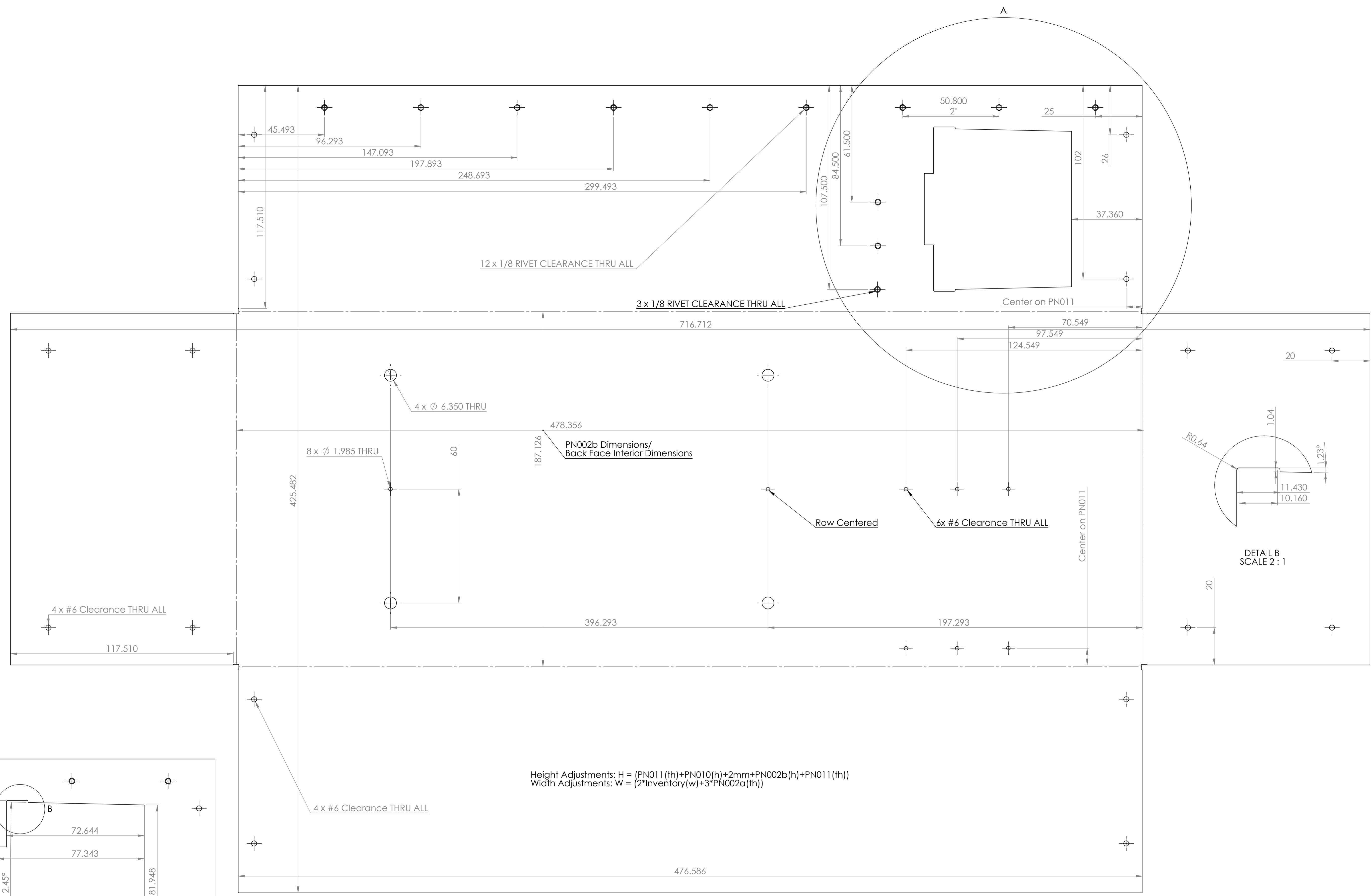

Height Adjustments: $H = (PN011(th) + PN010(h) + 2mm + PN002b(h) + PN011(th))$
 Width Adjustments: $W = (2 * Inventory(w) + 3 * PN002a(th))$

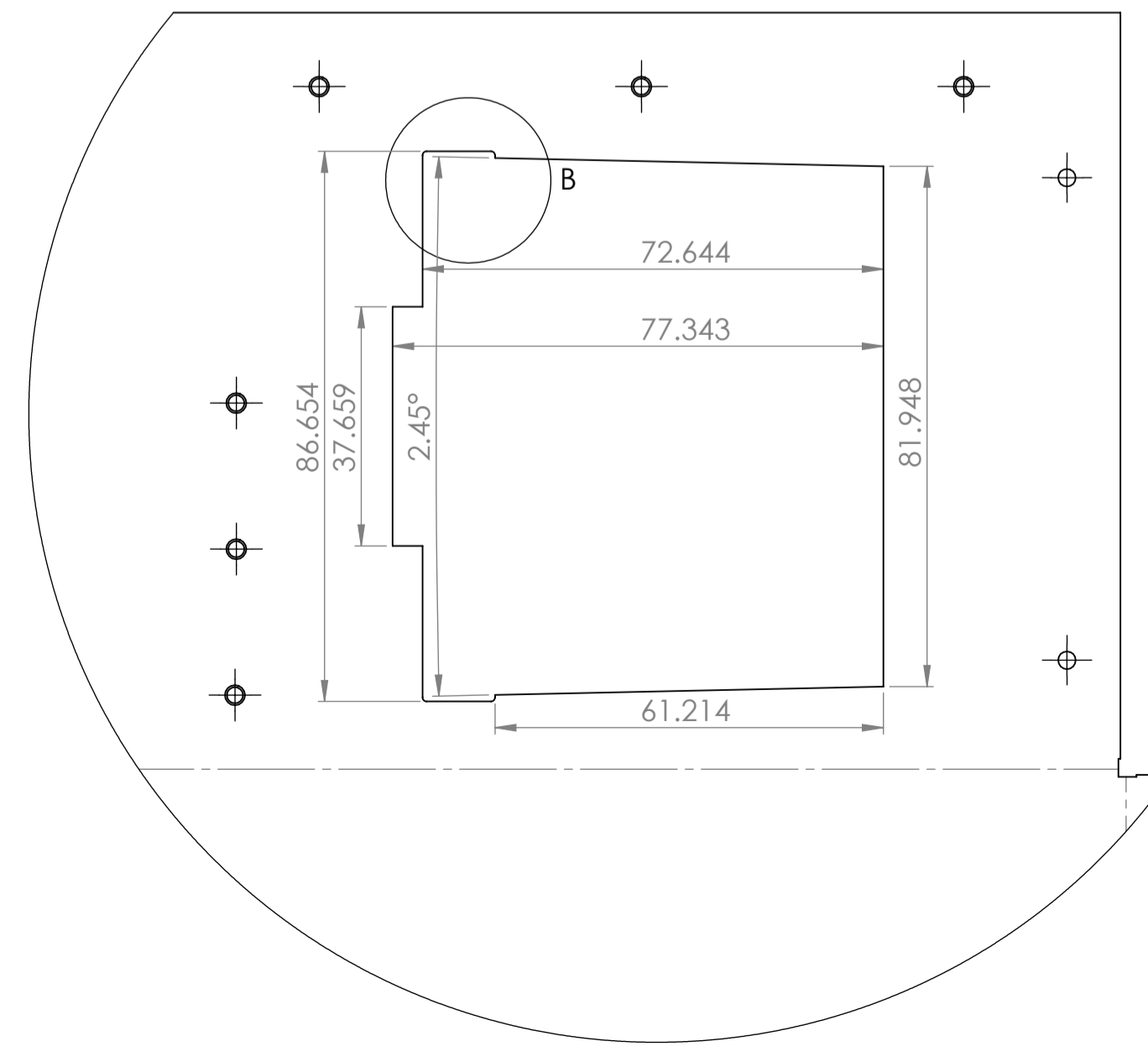

UNLESS OTHERWISE SPECIFIED: DIMENSIONS ARE IN MILLIMETERS		FINISH: Sand & Debur		DEBUR AND BREAK SHARP EDGES		DO NOT SCALE DRAWING		REVISION 1	
SURFACE FINISH: TOLERANCES: LINEAR: ANGULAR:								1 of 1	
DRAWN	NAME JRB	SIGNATURE	DATE 06/23/14					Case	
CHK'D								0.3_PN007	
APP'VD								A1	
MPG									
Q.A.				MATERIAL: 26-32ga Steel		DWG NO.			
				WEIGHT:		SCALE: 1:1		SHEET 1 OF 1	

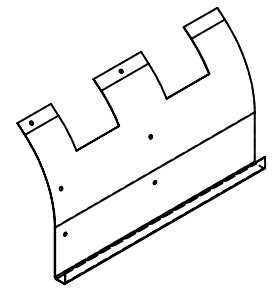
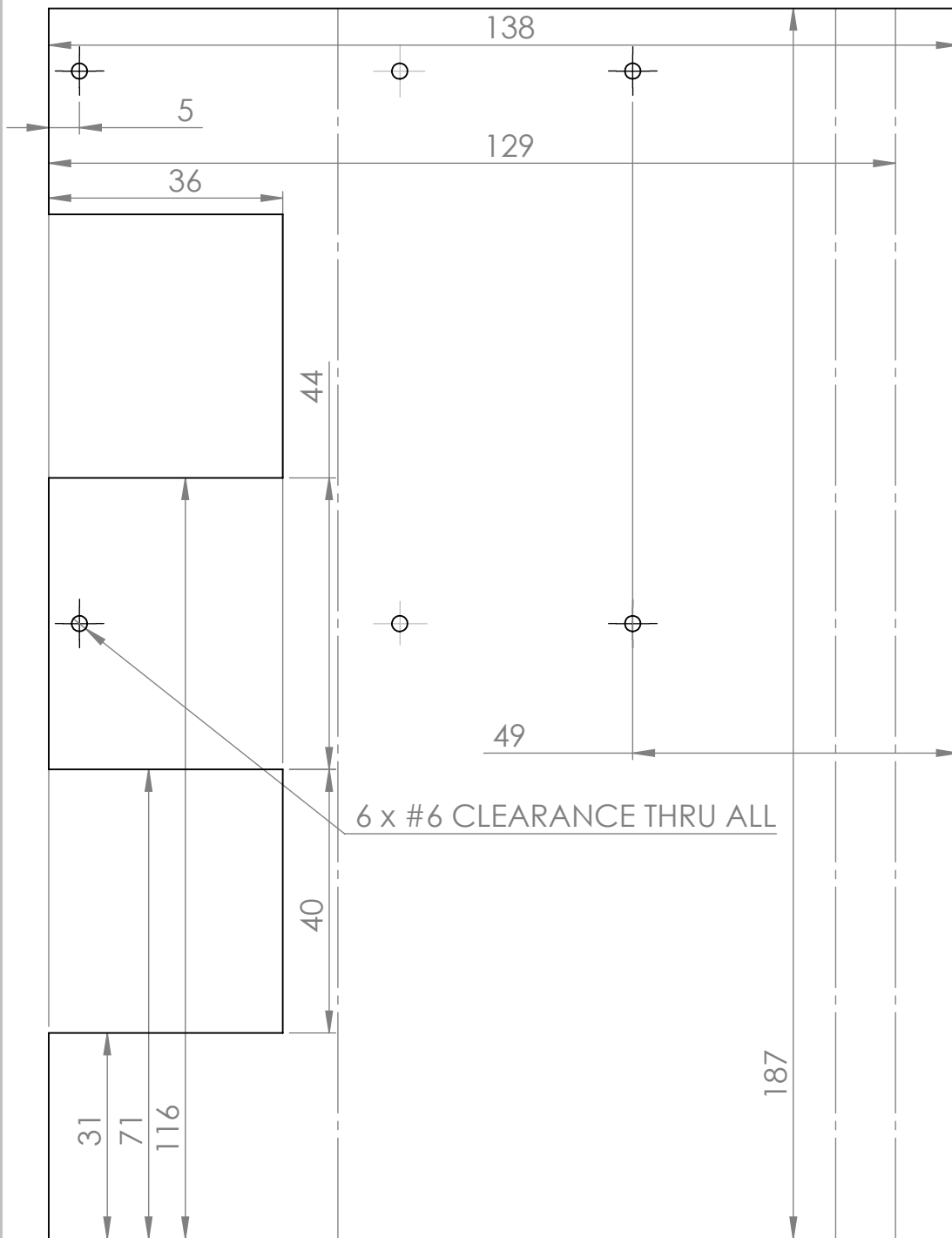

UNLESS OTHERWISE SPECIFIED:
DIMENSIONS ARE IN MILLIMETERS
SURFACE FINISH:
TOLERANCES:
LINEAR:
ANGULAR:

FINISH:

Debur & File

DEBUR AND
BREAK SHARP
EDGES

DO NOT SCALE DRAWING

REVISION

2

1x

	NAME	SIGNATURE	DATE		
DRAWN	JRB		06/17/14		
CHK'D			06/24/14		
APPV'D					
MFG					
Q.A				MATERIAL:	
				WEIGHT:	

TITLE:

Vending Faceplate

DWG NO.

0.3_PN008

A4

SCALE:1:1

SHEET 1 OF 1

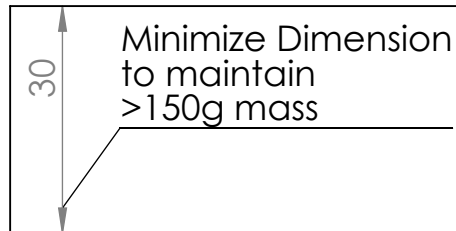
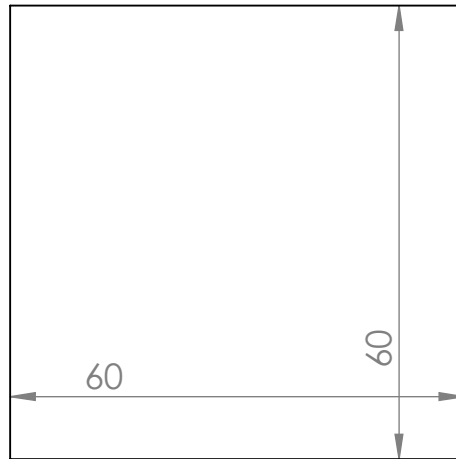
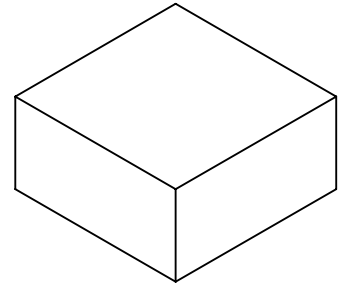

UNLESS OTHERWISE SPECIFIED: DIMENSIONS ARE IN MILLIMETERS SURFACE FINISH: TOLERANCES: LINEAR: .5mm ANGULAR: N/A				FINISH: Sand/Polish smooth & clean		DEBUR AND BREAK SHARP EDGES		DO NOT SCALE DRAWING		REVISION A			
								TITLE: <h1>Inventory Follower</h1>					
DRAWN		NAME		SIGNATURE		DATE							
CHK'D						4/16/2014							
APPV'D													
MFG													
Q.A						MATERIAL: High-Density Plastic/Wood /Equivalent		DWG NO. <h2>0.3_PN009</h2>		A4			
				WEIGHT:				SCALE 1:1		SHEET 1 OF 1			

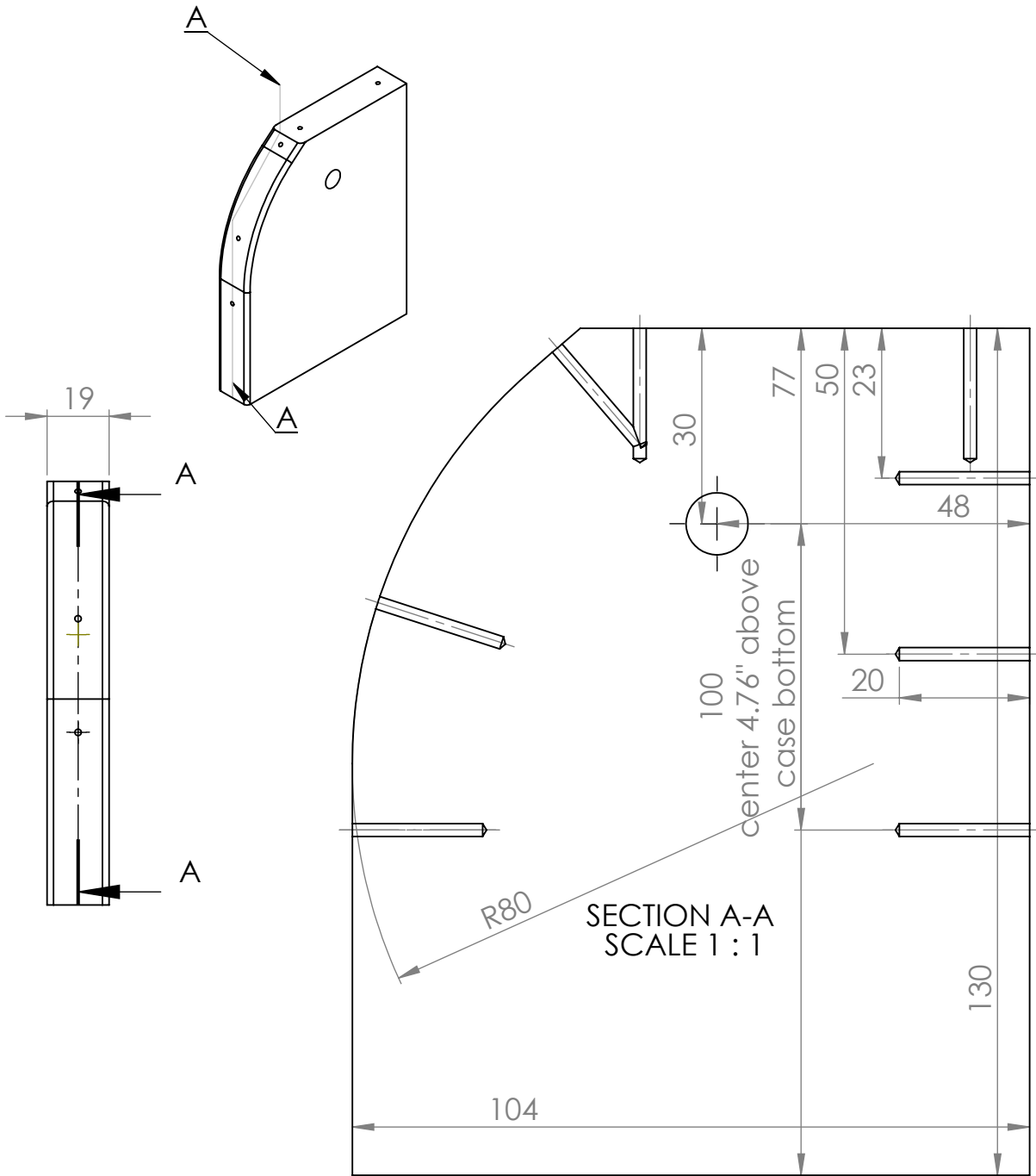

UNLESS OTHERWISE SPECIFIED:
 DIMENSIONS ARE IN MILLIMETERS
 SURFACE FINISH:
 TOLERANCES:
 LINEAR:
 ANGULAR:

FINISH:
 Sand Smooth

DEBUR AND
 BREAK SHARP
 EDGES

DO NOT SCALE DRAWING

REVISION 2

2x

	NAME	SIGNATURE	DATE		
DRAWN	JRB		06/17/14		
CHK'D	JRB		06/24/14		
APPV'D					
MFG					
Q.A					

TITLE:
Cam Mechanism Mount

DWG NO. **0.3_PN010**

A4

WEIGHT:

SCALE:1:2

SHEET 1 OF 1

MATERIAL:
 >38mm Wood or
 Equivalent

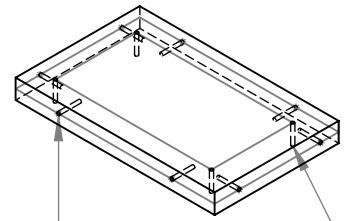
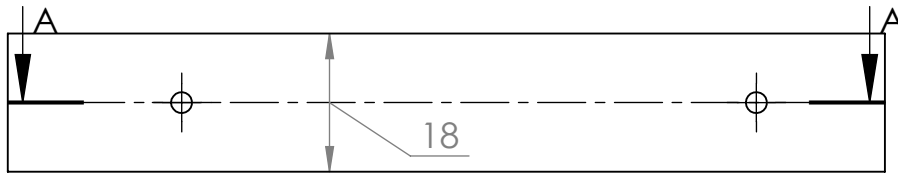

8 x ϕ 2.778 ∇ 20
 4 x ϕ 2.778 THRU ALL

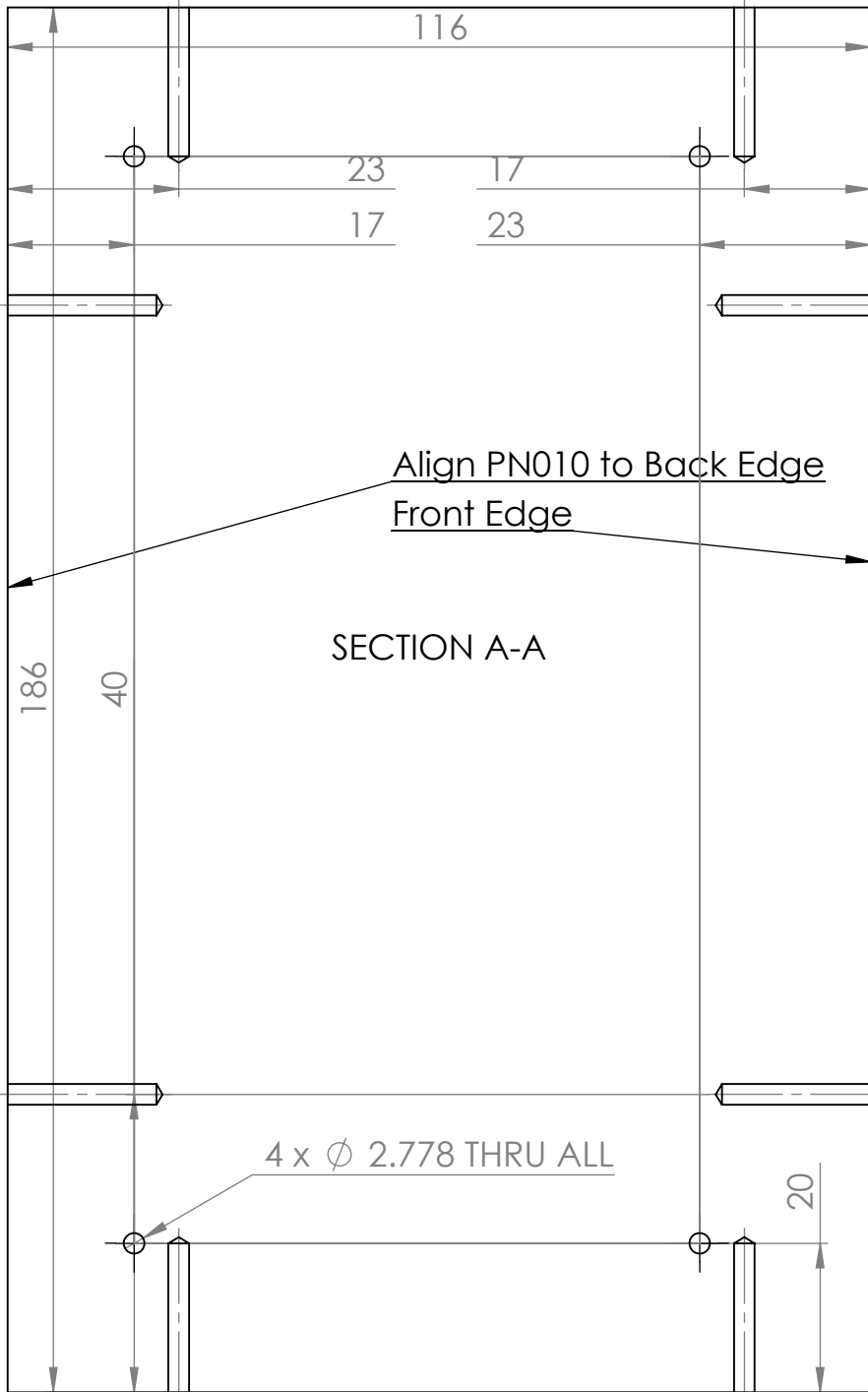

UNLESS OTHERWISE SPECIFIED:
 DIMENSIONS ARE IN MILLIMETERS
 SURFACE FINISH:
 TOLERANCES:
 LINEAR: .5mm
 ANGULAR: N/A

FINISH:

Sand Smooth

DEBUR AND
 BREAK SHARP
 EDGES

DO NOT SCALE DRAWING

REVISION

A

2x

	NAME	SIGNATURE	DATE		
DRAWN	J.R.B.		4/16/2014		
CHK'D	JRB		4/27/14		
APPV'D					
MFG					
Q.A					
				MATERIAL:	
				Wood or Equivalent	
				WEIGHT:	

TITLE:

Case Endcaps

DWG NO.

0.3_PN011

A4

SCALE:1:1

SHEET 1 OF 1

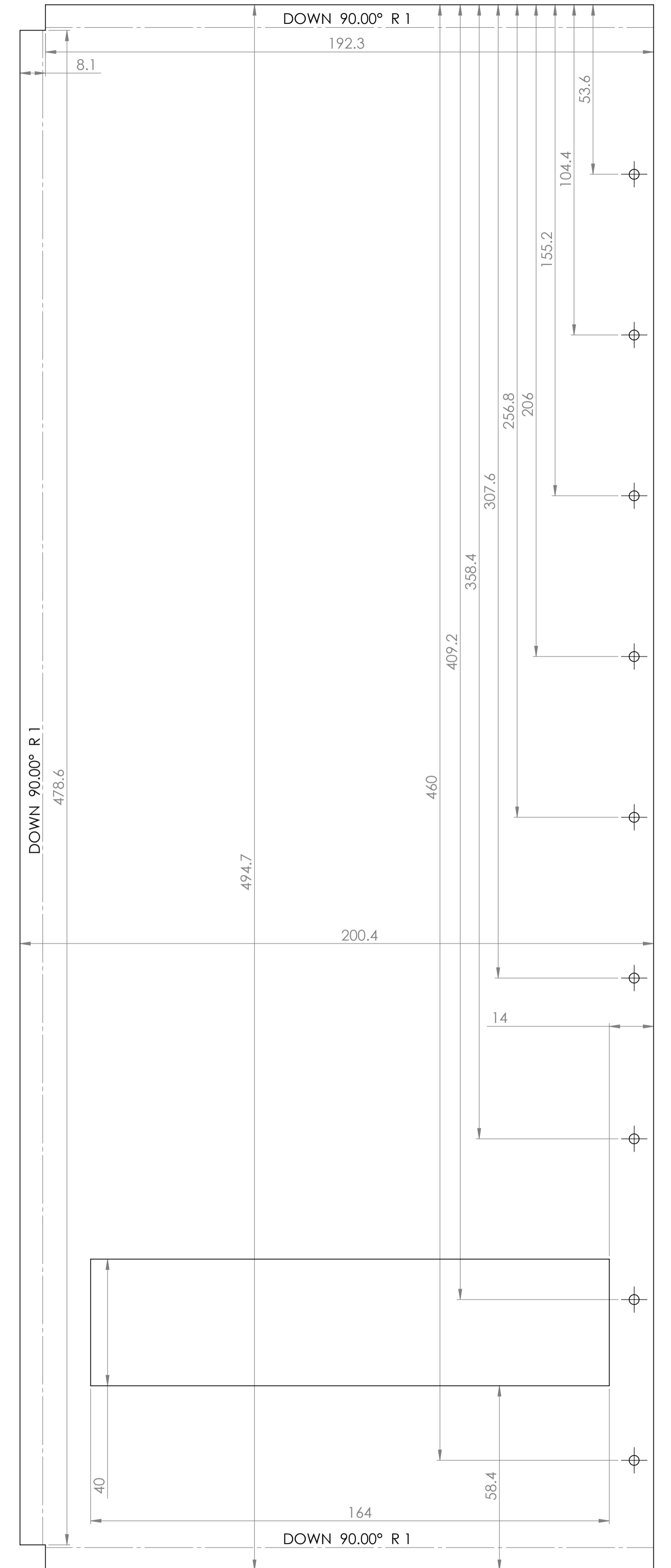
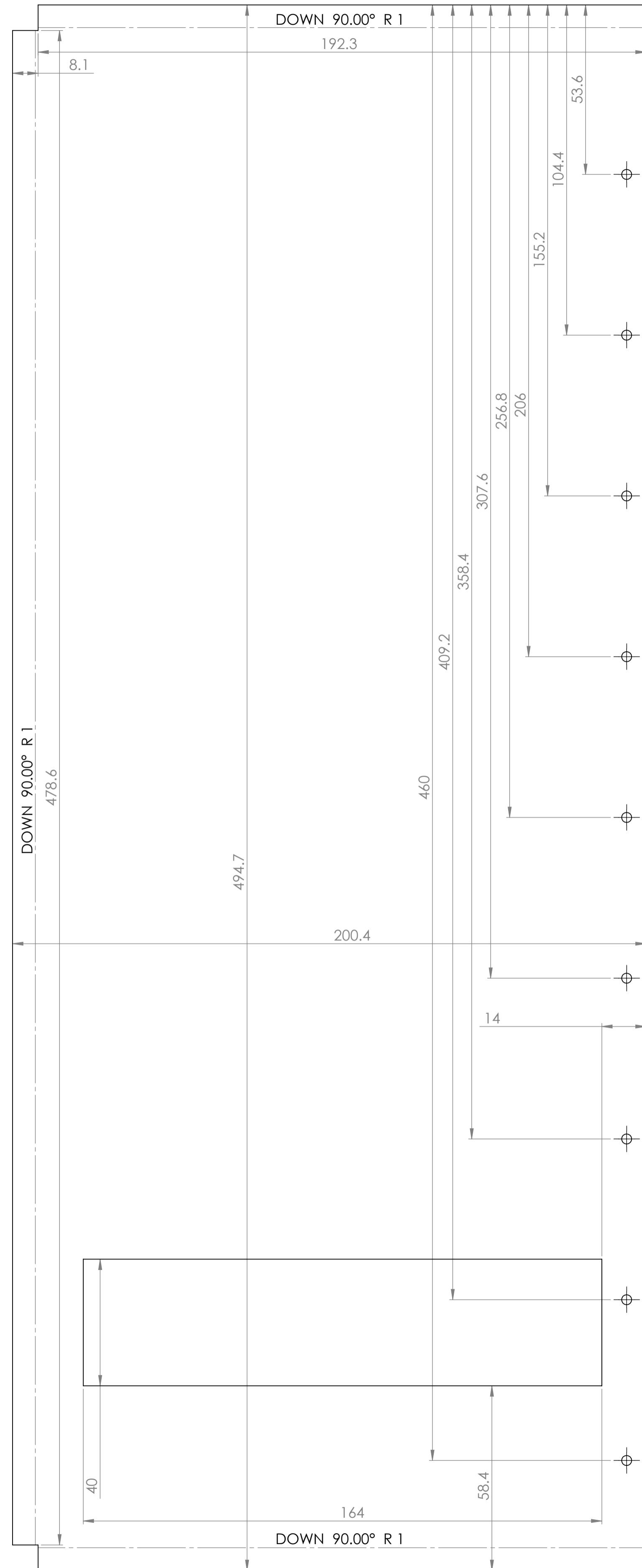
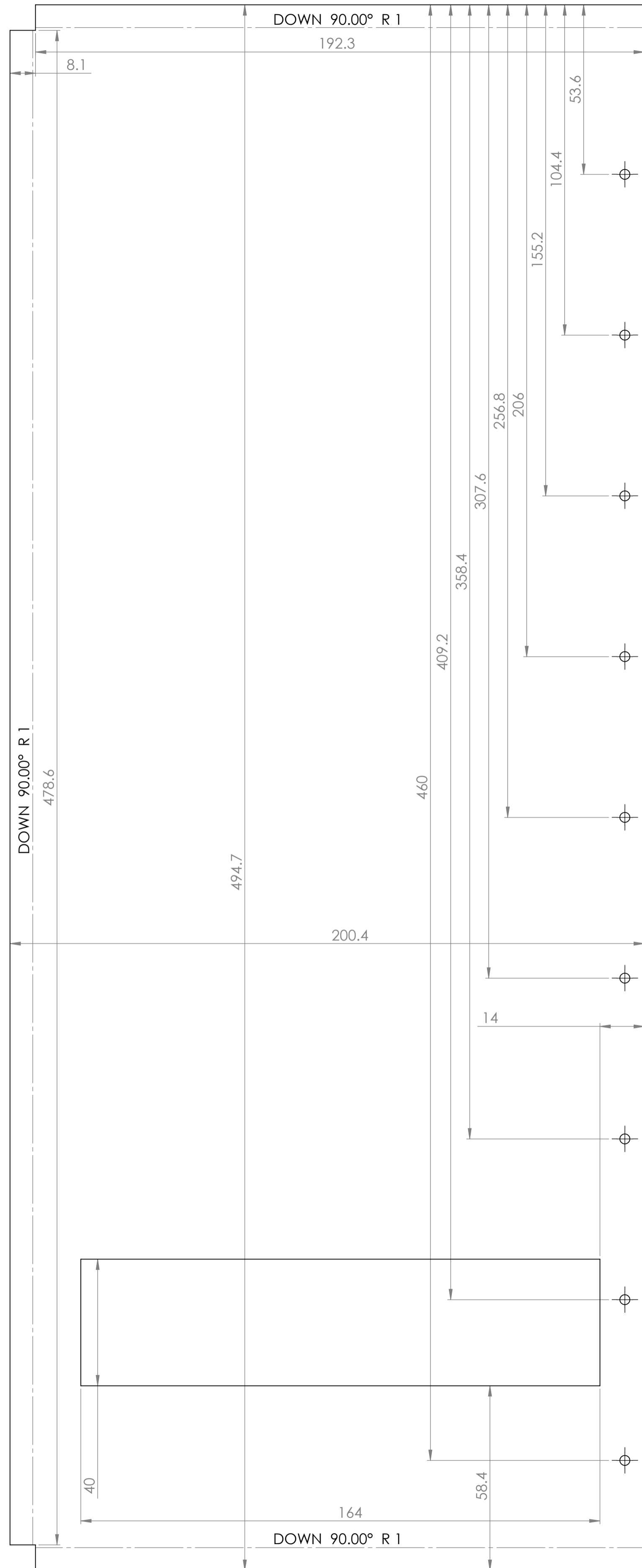

UNLESS OTHERWISE SPECIFIED: DIMENSIONS ARE IN MILLIMETERS SURFACE FINISH: TOLERANCES: LINEAR: ANGULAR:				FINISH: Debur	DEBUR AND BREAK SHARP EDGES	DO NOT SCALE DRAWING	REVISION
					1x		
					Lid		
					0.3_PN012		
					A1		
					SHEET 1 OF 1		

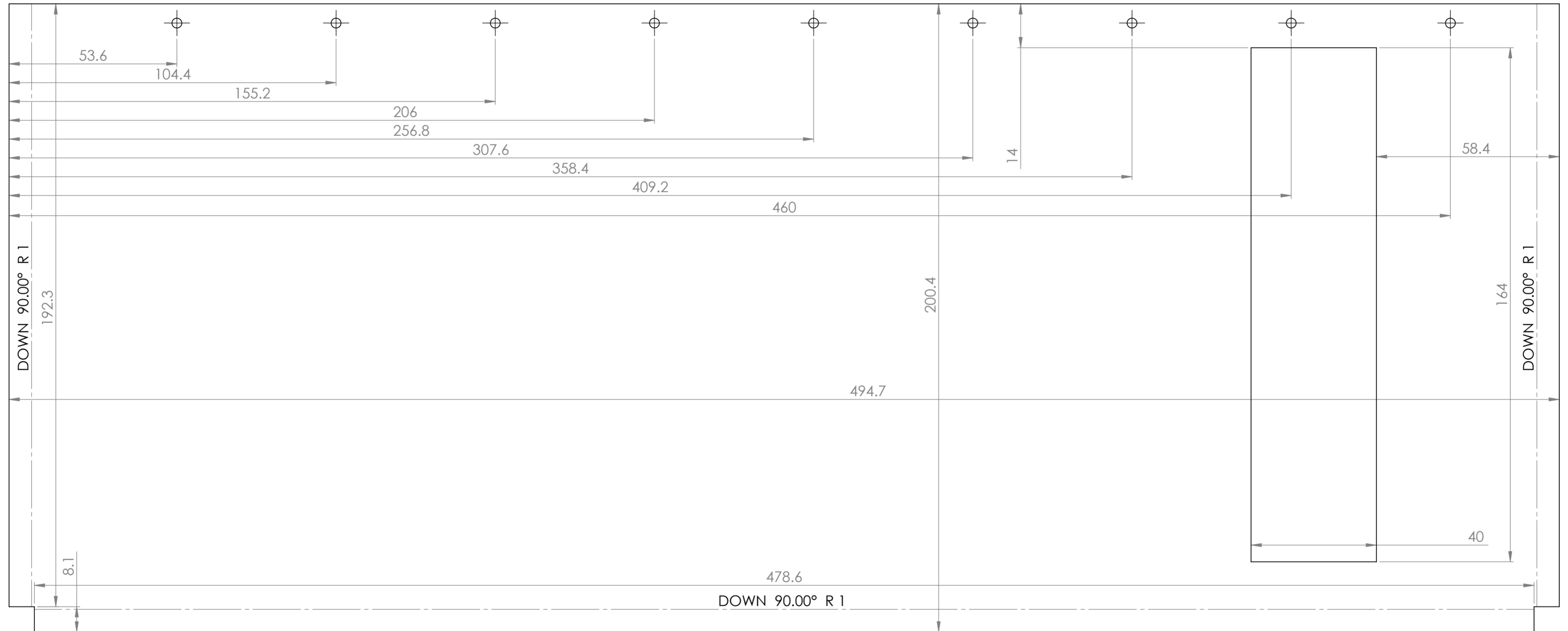

UNLESS OTHERWISE SPECIFIED: DIMENSIONS ARE IN MILLIMETERS				FINISH: Debur		DEBUR AND BREAK SHARP EDGES		DO NOT SCALE DRAWING		REVISION	
SURFACE FINISH:								1x			
TOLERANCES:								TITLE:		Lid	
LINEAR:								DWG NO.		0.3_PN012	
ANGULAR:								SCALE:1:1		SHEET 1 OF 1	
DRAWN		NAME		SIGNATURE		DATE		MATERIAL:		A2	
CHK'D		JRB				06/26/14		26-32ga Al/St			
APP'VD		JRB				06/26/14		WEIGHT:			
MFG											
Q.A											

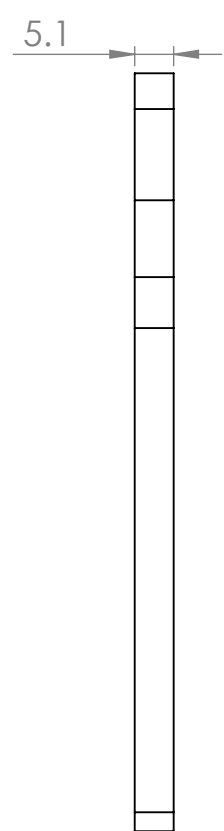
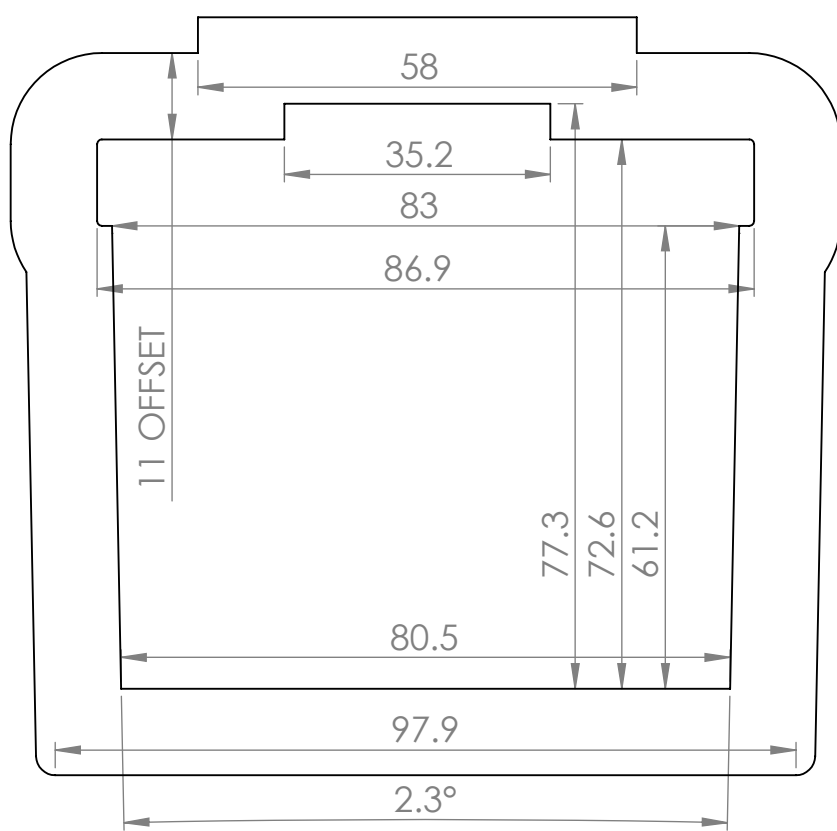
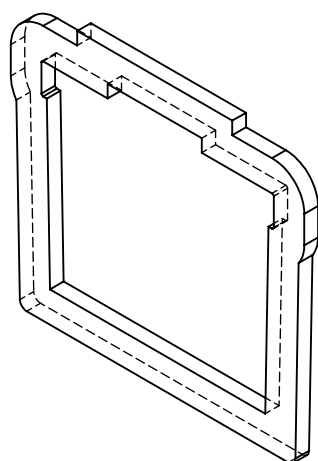

UNLESS OTHERWISE SPECIFIED:
DIMENSIONS ARE IN MILLIMETERS
SURFACE FINISH:
TOLERANCES:
LINEAR:
ANGULAR:

FINISH:
Smooth

DEBUR AND
BREAK SHARP
EDGES

DO NOT SCALE DRAWING

REVISION

1x

	NAME	SIGNATURE	DATE		
DRAWN	JRB		06/26/14		
CHK'D	JRB		06/26/16		
APPV'D					
MFG					
Q.A					
				MATERIAL:	
				Wood, Plastic, Equiv.	
				WEIGHT:	

TITLE:	Coin Mech Spacer	
DWG NO.	0.3_PN013	A4
SCALE:1:1	SHEET 1 OF 1	

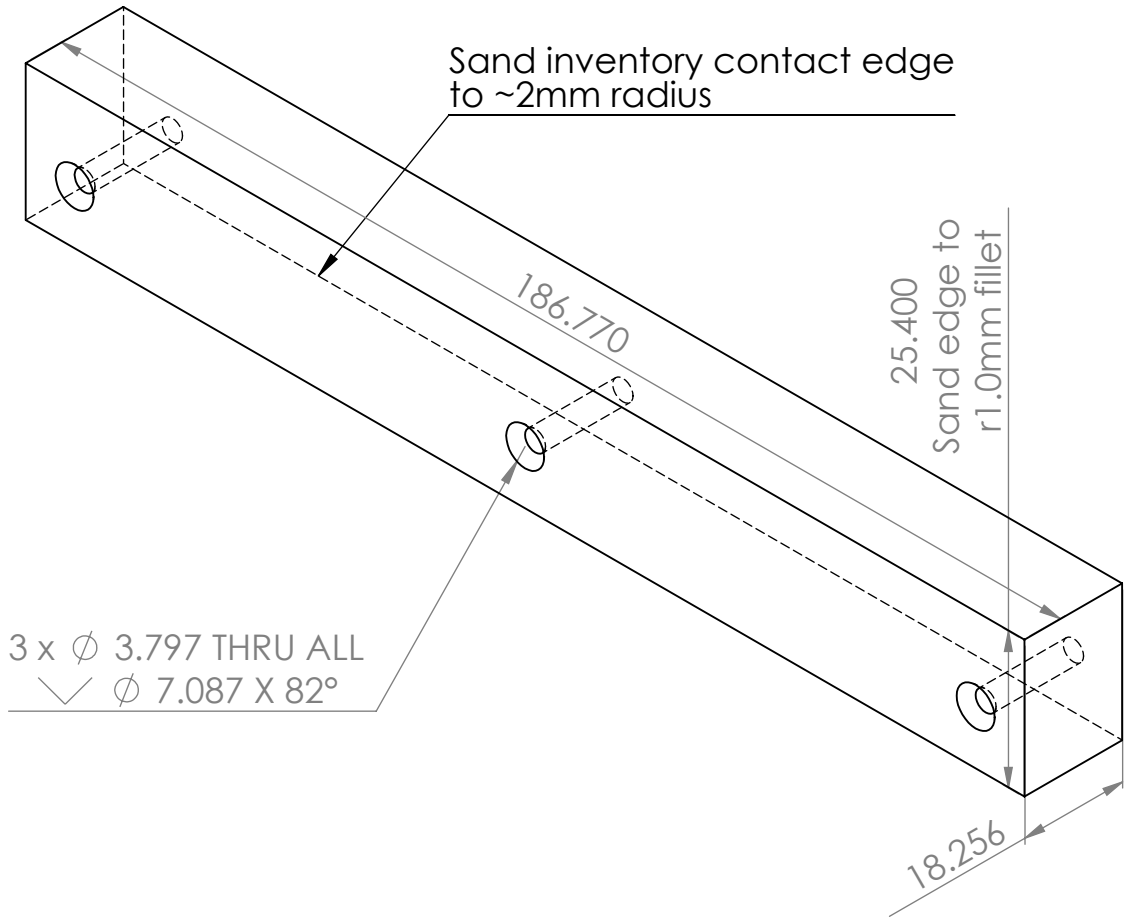
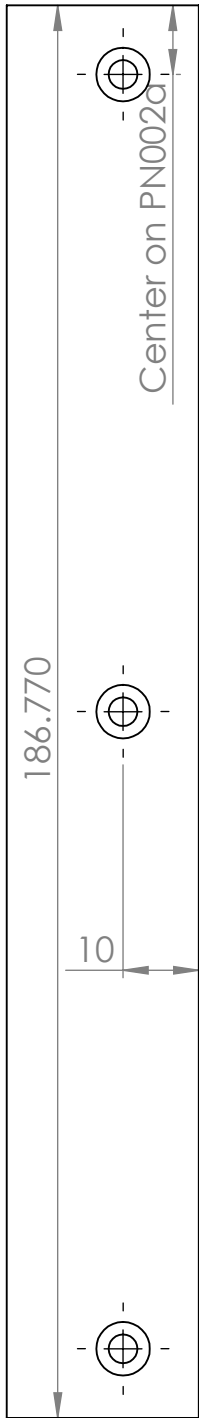

UNLESS OTHERWISE SPECIFIED:
DIMENSIONS ARE IN MILLIMETERS
SURFACE FINISH:
TOLERANCES:
LINEAR:
ANGULAR:

FINISH:
Sand smooth as noted

DEBUR AND
BREAK SHARP
EDGES

DO NOT SCALE DRAWING

REVISION 2

1x

	NAME	SIGNATURE	DATE		
DRAWN	JRB				
CHK'D					
APPV'D					
MFG					
Q.A				MATERIAL:	
				Wood or Equivalent	
				WEIGHT:	

TITLE:

Inventory Faceplate

DWG NO.

0.33_PN001a

A4

SCALE:1:1

SHEET 1 OF 1