

MONROE TOWNSHIP MUNICIPAL UTILITIES AUTHORITY
RULES AND REGULATIONS FOR
PROPOSED SEWERAGE SYSTEMS

S:1 CONDITIONS REQUIRING AUTHORITY APPROVAL.

Any developer shall be required to obtain approval of his/her development from the Authority. All property owners shall be subject to provisions of Chapter 92, Sewers of the Code of the Township of Monroe, New Jersey.

S:2 DEFINITIONS.

As used in these Rules and Regulations, unless a different meaning clearly appears from the context, the following words shall have the following meanings:

Applicant: Means a developer submitting an application for development. (MLUL).

Authority: Means the Monroe Township Municipal Utilities Authority.

Block: Means an area delineated as such on the Tax Map of the Township of Monroe.

Developer: Means the legal or beneficial owner or owners of a lot or of any land proposed to be included in a proposed development, including the holder of an option or contract to purchase, or other person having an enforceable proprietary interest in such land. (MLUL).

Developer, Original: Means any developer or owner of a vacant lot who installs a sewer improvement pursuant to these Rules and Regulations to be owned by the Authority which improvement is installed larger and/or deeper in order to be capable of being utilized by other developers.

Development: Means the division of a parcel of land into two or more parcels; the construction, reconstruction, conversion, structural alteration, relocation or enlargement of any building or other structure, or of any mining excavation or landfill; and any use or change in the use of any building or other structure, or land, or extension of use of land, for which permission may be required per the Municipal Land Use Law. (MLUL).

Easement: The right to use the land of another for a specific purpose.

Equivalent Dwelling Unit: Shall be defined as follows:

- a. Residential:

Each single family dwelling or a portion of a structure normally occupied by a single family.

Each single family apartment dwelling in a multiple family structure or structures.

b. Other Than Residential:

For users other than residential, each commercial, industrial, professional, institutional, public, or other user not heretofore mentioned, one unit shall equal the average residential consumption per household as defined in N.J.S.A. 40:14A-21 and shown on the current rate schedule.

GDP Applicant: Means any applicant to the Monroe Township Municipal Utilities Authority who has: a. received overall preliminary site plan approval for a planned development from the Monroe Township Planning Board for a tract of a minimum of 400 contiguous acres; b. intends to develop as a single entity; and c. has obtained first phase development approval of the planned development from the Monroe Township Planning Board.

House Service Connection: Means the pipe and appurtenances between the Authority's street and main and the individual cleanout, including the cleanout.

Lot: Means a designated parcel, tract, or area of land established by a plat, or otherwise as permitted by law, and to be used, developed, or built upon as a unit. (MLUL).

Major Application - Sewer: A major application is any application other than a minor application. All commercial/industrial applications are major applications.

Minor Application - Sewer: A minor application is any residential application which does not involve an extension of Monroe Township Municipal Utilities Authority sewer facilities and which will not connect more than 3 houses to the Monroe Township Municipal Utilities Authority sewer system.

Original Developer: See "Developer, Original."

Plat: A map of a development.

Revision or Modification: Means any change in a project which has received M.T.M.U.A. approval, which said change requires a change in the physical improvements to be installed by the applicant or a change in the proposed use to be connected to the Monroe Township Municipal Utilities Authority Sewer System.

Right-of-Way: Means a strip of land occupied or intended to be occupied by a street, crosswalk, railroad, road, electric transmission line, gas pipeline, water main, sanitary or storm sewer main, shade tree, or for another special use.

Sewer Capacity: Means the amount of flow which the sewerage system can carry without surcharging backup. The sewer capacity varies from point to point in the overall

system so care must be taken to describe the capacity of all downstream sewers and pumping stations.

Sketch Plan: Means the sketch map of a development of sufficient accuracy to be used for the purpose of discussion and classification and meeting the requirements of these Rules and Regulations.

Street: Means any street, avenue, boulevard, road, parkway, viaduct, drive, or other way, which is an existing State, county, or municipal roadway, or which is shown upon a plat heretofore approved pursuant to law, or which is approved by official action as provided by the MLUL, or which is shown on a plat duly filed and recorded in the office of the county recording officer prior to the appointment of a planning board and the grant to such board of the power to review plats; and included the land between the street lines, whether improved or unimproved, and may comprise pavement, shoulders, gutters, curbs, sidewalks, parking areas, and other areas within the street lines. (MLUL).

Township: Means the Township of Monroe, in the County of Middlesex, New Jersey.

S:3 SUMMARY OF REQUIREMENTS FOR SUBMISSION OF APPLICATIONS

S:3-1 Application for Preliminary Approval of Plans for Sewer Systems.

- a. An applicant for preliminary approval shall be required to submit:
 1. Preliminary Application Forms
 2. General Plan (paper and digital copies). Digital copies shall meet or exceed the requirement of NJDEP Mapping and digital standards.
 3. Fees
 4. Preliminary Engineer's Report
 5. Wetlands Delineation by N.J.D.E.P.
 6. M.C.U.A. forms where applicable
 7. Attend meetings
 8. Taxpayer I.D. form W-9 (for deposit of escrow fees)

S:3-2 Tentative Approval of Plans for Sewer Systems.

- a. An application for Tentative approval is required when extending Authority facilities. An applicant for Tentative approval shall be required to submit:

1. Tentative Application Forms
2. Engineer's Cost Estimate
3. Engineer's Report
4. General Map (Overall sewer plan showing manhole numbers and direction of flow, at a scale to maximize one 24" x 36" sheet)
5. Plan and Profiles (Paper and digital copies)
6. Specifications
7. Details of Construction (The MTMUA has supplied standard details which have been reviewed and approved; however, applicant may submit other details for review and approval).
8. N.J.D.E.P. Permit Application to Construct Sanitary Sewers (if necessary)
9. M.C.U.A. Permit Forms (if necessary)
10. USEPA Grant Condition Waiver (if necessary)
11. N.J.D.E.P. Environmentally Sensitive Areas mapping revision (L.O.I.) or Presence/Absence Letter
12. Fees
13. Attend meetings

S:3-3 Application for Final Approval of Plans for Sewer Systems.

- a. An applicant for final approval must submit:
 1. Final Application Forms
 2. Engineer's Estimate
 3. Engineer's Report
 4. General Map (Paper and digital copies)
 5. Plans and Profiles (Paper and digital copies)
 6. Specifications
 7. Details of Construction

8. Deed(s) of easement(s) with separate map and metes and bounds descriptions.
9. Copies of all required N.J.D.E.P. and/or MCUA, D&R CC Permits
10. Performance Guarantee
12. Fees
13. Attend meetings

S:3-4 Approval of Plans by State and County Agencies and Others.

- a. Prior to construction an applicant must submit the following approvals where necessary:
 1. SCS
 2. County and/or Local Road Opening Permits
 3. Confined Space Entry Program
 4. Cut Sheets
 5. Shop Drawings
 6. Dewatering plans/Permits

S:3-5 Application for Individual Sewer Connection.

- a. Where a lateral and cleanout exist to the lot, an applicant for sewer connection must submit:
 1. Duplicate Application Form for Individual Connection
 2. Connection Fee as Per Current Rate Schedule
 3. For homes built after September 30, 1980, either a wetlands L.O.I. (with USEPA mapping revision or grant waiver) or presence/absence letter from a qualified professional.
- b. Where a lateral and cleanout to the lot do not exist, the applicant must make a Preliminary Application and submit permits, bonds and applicable fees.

S:3-6 Revised Application.

- a. An applicant for a revised application must submit:
 - 1. Revised Application Forms
 - 2. Engineer's Cost Estimate
 - 3. Engineer's Report
 - 4. General Map
 - 5. Plan and Profile
 - 6. Specifications
 - 7. Details of Construction
 - 8. Fees
 - 9. Revised Permits (if necessary)
 - 10. Attend meetings.

S:4 APPLICATION TO THE AUTHORITY.

- a. Preamble.
 - 1. Time for Submission.

All applications must be complete and submitted at least fourteen (14) calendar days before a regularly scheduled agenda meeting of the Authority. All items must be collated and packaged together for each application. Application number, once assigned, shall appear on all subsequent documents submitted.
 - 2. Incomplete Applications.

Should it be found upon review of any application that the application is deficient in any items as required above, the application shall be deemed to be incomplete and shall not be heard at the Authority meeting until all deficiencies are corrected. If, upon review of the plan submission, it should be determined that the plans or technical submissions are deficient in the requirements set forth herein, the application shall also be deemed incomplete. Resubmission of any plan which has been deemed incomplete must be accompanied with the required

application number. Piecemeal submissions are discouraged; the Authority reserves the right to return incomplete applications.

3. Separate Application for Water System Required.

Each application for preliminary approval must also be accompanied by a separate application for preliminary approval for a water system. All applications are to be signed by the applicant or an officer of the applicant. If the applicant is not the owner, the owner must also sign. The applicant or his/her representative should be present at the agenda meeting to discuss the application.

4. Concurrent Applications.

Concurrent submission of applications for two or more different stages (e.g. Preliminary and Tentative) of Authority approval on any project are discouraged, but may be requested prior to submission and may be approved, subject to the discretion of the Authority.

5. Expiration of Approvals.

Approved Preliminary applications will be null and void after a one-year period from the date of Resolution, approved Tentative applications will be null and void after a one-year period from the date of Resolution, and approved Final applications will be null and void after a one-year period if no construction takes place or after a two-year period if all work has not been completed. Date of approval is the date of the meeting at which the Authority grants its total or conditional approval of an application. Extension of approvals may be approved in accordance with Section 4.6 of these rules.

6. Unused Deposits.

Unused portions of deposits on approved applications that become null and void are refundable within two months after request in accordance with N.J.S.A. 40:14B-20.1.

7. Conditions of Approvals.

Approvals are not deemed valid until all conditions of approval have been satisfied.

8. Payment of Expenses.

Applicants requesting special meetings of the Authority to consider their applications will be responsible for payment of all

expenses which are incurred by the Authority (such as advertising costs, secretarial costs, attendance of staff members, attendance of professionals, etc.) in conducting such a meeting. The expenses for secretarial cost and staff members shall be at one and one-half times their hourly rate.

9. Reserved Capacities.

No capacity shall be reserved in the Authority's sewer system for any development until that development has received approval of its application for final approval as required by Section S:3-3 and Section S:4-5, and all fees have been paid.

10. Grant Restrictions.

Portions of the Authority's and the MCUA's sewerage system were funded in part by an EPA Grant which contained certain restrictions. Consequently, no sewer hookup or other connection to this system will be permitted from any building, facility or other construction on land within wet lands or the 100 year floodplain which was undeveloped as of September 1, 1980.

11. Drawings, Designs and Reports.

All drawings, design reports, specifications and estimates submitted by the applicant must bear the signature and raised seal of the applicant's engineer. All sheets shall be numbered consecutively. Drawings not meeting reasonable engineering standards as to accuracy, correctness and neatness will not be accepted.

S:4-1 Application for Preliminary Approval of Plans for Sewer Systems.

a. Preliminary Application Forms.

1. An application for preliminary review of the proposed sewer system for the proposed development, shall be submitted to the Authority for a ruling on whether a comprehensive sewer system is required.
2. Information as to ownership. If Applicant is a corporation or partnership, a list of the names and addresses of all stockholders or individual partners owning at least 10% of its stock of any class or at least 10% of the interest in the partnership as the case may be, as required by N.J.S.A. 40:55D-48.1 and 40:55DF-48.2.

3. This application shall be filed, in duplicate, on a form which may be obtained from the Authority.
 4. All commercial/industrial applicants must complete the MTMUA Industrial Waste Survey Form (which can be obtained from the MTMUA)
- b.. Preliminary Plan.
1. The applicant shall furnish two (2) copies of a general plan showing the location of the development in the Township with the location of the nearest Authority existing facilities in the area, and description of the proposed method of connection.
 2. The sketch plat may be incorporated in the general plan. Plans must be of uniform size, 24" x 36".
 3. The General Plans shall be based on an acceptable survey and drawn at a scale of not more than two hundred (200) feet to the inch and shall contain at least the following information:
 4. A title sheet shall be submitted which includes items (a, b, c, d & f below:
 - (a) Proposed development name, identifying title, or Block and Lot No(s).
 - (b) Name and address of the owner of the tract.
 - (c) Name and address of the developer (if other than the owner).
 - (d) Name, address, and professional seal of person preparing plan.
 - (e) Development details.
 - (f) Key map showing the location of the tract in the municipality.
 - (g) The location of that portion of the tract which is to be developed relative to the entire tract.
 - (h) The location of any wetland and/or flood hazard areas on the tract or a licensed P.E.'s certification as to the absence of same based on a review of available mapping and on-site observation.

- (i) The location of all existing sewers and water mains on the tract. Also indicated to the same scale as the rest of the plan shall be the proposed location and means of connection to the existing sewer system.
 - (j) The general layout and number of all proposed lots.
 - (k) The smallest lettering size shall be .10 inches.
 - (l) All proposed easements.
 - (m) Based on USC & GS 1988 vertical datum and N.J. Coordinate Plane Systems. (NAD '83)
- 5. An overall plan of the proposed application at a scale which maximizes one 24" x 36" plan sheet (include g, h, l, h & l above).
- c. Fees.

Fee as per fee schedule attached shall accompany the application.
- d. Preliminary Engineer's Report.
 - 1. Provide sewer capacity required, using current N.J.D.E.P. standards, with calculations indicating the adequacy of the downstream pipes, for average and peak consumption rates.
 - 2. As per NJAC 5:21-1.5(d)2, the M.T.M.U.A. is seriously concerned with the depletion of non-renewable resources, and wishes to promote the conservation of energy wherever feasible.
 - 3. Provide sufficient information to enable the Authority's Engineer to determine if site can be served by gravity. The determination of whether service is provided by gravity or PS/force main will be based on CFR C U.S.E.P.A. "Cost Effectiveness Guidelines". This analysis is to be made to satisfy the intent and purpose of NJAC 5:21-1.3 (a) 2 to "provide site improvement standards that are both sound and cost effective".
- e. Attend Meetings:

In addition, the applicant should appear before the Authority at a regularly scheduled agenda meeting to discuss the application with the Authority. The purpose of this discussion shall be to establish the general guide lines to be followed by the applicant in developing the sewer plan for the project and to further define the project.

S:4-2 Application for Tentative Approval of Plans for Sewer Systems.

- a. These Rules and Regulations are consistent with N.J.A.C. 5:21, Residential Site Improvement Standards. Any questions as to this consistency should be raised prior to approval of plans and specifications in order not to create delays or unsafe conditions in the field.
- b. Tentative Application Forms.
 1. If a sewer system is required, the applicant must submit an application, in duplicate, for Tentative approval on a form to be furnished by the Authority. The then current Sanitary Sewer Master Plan, with these Rules and Regulations, will govern the approximate sizes and location of mains, and places of discharge.
 2. If the size of any sewer main, as shown by the applicant's Engineer, and checked by the Authority's Engineer, is inadequate for the future requirements of the area, or if the Authority requires a pumping station of greater capacity or head than that required by the applicant, the applicant shall install the larger facility or facilities if required to do so by the Authority. The applicant shall be entitled to reimbursement from future developers utilizing the facilities in accordance with the reimbursement regulations contained in these rules and regulations.
 3. Individual connections shall be provided for each individual family dwelling proposed for connection. Each connection shall be provided with a cleanout two feet behind the curb line or edge of pavement or the easement line.
 4. Where a sanitary sewer passes conforming vacant lots and/or existing homes other than the ones proposed, it will be the applicant's responsibility to install laterals, deep house connections and cleanouts off wyes on mainline to same vacant lots and/or homes. It is the responsibility of the applicant's engineer to show building footprint, first floor elevation and location of existing septic tank which should be obtained from Middlesex County Health Department.
 5. Where the Authority issues a conditional Tentative approval, the applicant must make a resubmission including a cover letter indicating how the conditions were satisfied.
 6. All sewers must be designed on a separate plan, in which all water from roofs, cellars, streets and any other stormwater runoff areas must be excluded. No by-passes which allow raw sewage to be discharged from sewers or which permit storm water to enter the sewers shall be installed.

7. All sewer designs shall be based on N.J.D.E.P. regulations regarding gravity and force main sewers dated 6-6-94, or latest revision thereof.
 8. For a Tentative application to be considered complete, the applicant must submit New Jersey Department of Environmental Protection (N.J.D.E.P.) wetland delineation, USEPA mapping revisions, and CP-1 forms where required. The applicant shall obtain permits for all stream crossings, wetlands or encroachments from the N.J.D.E.P. Division of Water Resources, where required. Permits to construct sewer mains or other structures within the right-of-way limits of State, County, and Municipal Roads and all Railroads must be secured and paid for by the applicant.
 9. The applicant must also secure any necessary permits or clearances from any public utilities or agencies involved.
- c. Engineer's Estimate of Construction Cost. (2 copies) (signed and sealed by a NJ licensed P. E.)

Construction cost shall include, as a minimum, the following items where required: pipe, manholes, house connections and cleanouts, pumping stations, force mains, treatment plants, appurtenances, restoration of disturbed areas including existing roadways and easements, and preparation of as-built drawings. Construction cost estimate shall reflect costs of the Authority's installation of the facilities.

- d. Engineer's Report. (2 copies)
1. A complete engineer's report, setting forth the basis of design shall be submitted to the Authority for each project.
 2. All residential sewer mains shall be designed to carry 3 times the average daily flow upon full development of the tributary area. Peak factors for non-residential flow must be determined at the time of application. Average flow shall be calculated in accordance with current N.J.D.E.P. regulations.
 3. Sewers and force mains shall be designed to flow with a minimum velocity of not less than two feet per second at full flow, utilizing a Manning friction factor of $n = 0.013$ for all pipes other than PVC. The friction factor for PVC shall be $n = 0.010$. Based upon the projected peak flow, the pipe velocities shall be as close to 2.0 fps as practical; **INCREASING PIPE DIAMETER TO REDUCE SLOPE IS NOT ACCEPTABLE**, if velocities at peak design flow are less than 2 fps.

4. Minimum size and slopes of sewers shall be as shown on Table 1. in paragraph f,2(d)(13)(ii) below.
 5. Materials used in the construction of sewers, force mains, and outfalls shall be as follows: gravity sewers shall be constructed of reinforced concrete, polyvinyl chloride ductile iron, or sewer pipe.
 6. Residential developments may also choose to use clay pipe as specified. Force mains and outfalls shall be constructed of ductile iron, PVC, or precast reinforced concrete pipe, unless otherwise permitted by the Authority. House connections shall be constructed of a minimum diameter of 4 inch extra heavy weight cast or ductile iron soil pipe or polyvinyl chloride pipe or ABS. Deep house connections shall be provided where the sewer main centerline is more than 8 feet below the finished surface and shall be of heavy duty cast iron or PVC precast in reinforced concrete construction as shown on the Sewerage System Details attached hereto. Each house connection shall include a complete 4 inch diameter cast iron, ductile iron or PVC clean out assembly as shown on the sewage system details attached hereto. Material specifications and construction details are specified under "Detailed Information on Sewers". The Authority will establish flow standards for any construction not included in the above.
- e. General Map of the Entire Development:
- Two (2) copies of an overall map of the entire application shall be furnished, showing sewers, manholes, force mains, pumping stations, easements and the like for the entire development, necessary off-site facilities and the location of that portion of the tract to be developed relative to the entire tract. Maps shall also be supplied in digital format and be consistent with the N.J. State Plan Coordinate System. Digital copies shall meet or exceed the requirement of NJDEP Mapping and digital standards.
- f. Plans and Profiles of all Proposed Sewers, Pipelines and Structures:
1. Two sets of paper drawings shall be submitted and one compact disc containing digital copies of the plan. Digital copies shall meet or exceed the requirement of NJDEP Mapping and digital standards.
 2. The Plans shall contain the following:
 - (a) General Information
 - (1) Proposed development name, identifying title or block and lot no.(s).

- (2) Name and address of the owner of the tract.
- (3) Name and address of the developer, if other than owner.
- (4) Name, address and professional seal of person preparing plans.
- (5) Drawings uniform in size, 24" x 36".
- (6) Drawings at a scale of not more than fifty (50) feet to the inch.
- (7) The smallest lettering size shall be .10 inches. (No exceptions)

(b) Site Information.

- (1) A key map showing the location of the tract in the municipality.
- (2) The location of any wetlands, transition areas and flood hazard areas on the tract or within 50 feet of the tract.
- (3) Tract boundaries as determined from a legal description or engineering survey.
- (4) Existing contours of one (1) foot intervals on the tract. Datum, symbols and conventions shall refer to established USCGS elevations and standards based on 1988 vertical. Horizontal control must be consistent with the N.J. State Plan Coordinate System.
- (5) Locations of all existing buildings, streets, waterways, and other significant features.
- (6) Locations of all existing sewers, laterals, water mains, water services, culverts, fire hydrants, storm drains, catch basins, manholes, and other manmade features in and within three hundred (300) feet of the tract.
- (7) Locations of all existing easements and rights-of-way on the tract.
- (8) Results of boring logs and tests to indicate subsurface conditions on the tract including

potential for acid soils, and dewatering. Borings must be taken during the period January 1st and April 30th unless approved by the M.T.M.U.A. Engineer. Design Engineer's report to specify season high water table. Soil borings shall be taken on centerline at 100 to 200 foot intervals. Depth of boring below designed pipe invert should be 5 feet or more to allow for latitude in final design affecting this invert elevation, and to aid in the design of dewatering system(s) where needed. When soil borings indicate poor or unstable soils, boring depth will be a necessary depth requisite for kind of foundation such as bearing piles or replacing poor soil with other consolidating materials. Soil Engineers Report shall include acid soils and methods for its mitigation. Also the report shall include dewatering recommendation and a depth of groundwater encountered at each soil boring. No test pit will be allowed as a soil boring substitute. (Manual of Engineering Practice 8, A.S.C.E.)

(c) Planning Information.

- (1) Proposed locations of all roads, curbs, and sidewalks within and adjacent to the tract, with a notation as to the proposed widths of their rights-of-way.
- (2) Proposed locations of all lot lines and front set-back lines. All lots shall be numbered and all lot lines dimensioned.
- (3) Proposed locations and widths of all easements and rights-of-way to be established on the tract and the purpose for which they are to be established. Easements are to be avoided whenever possible.
- (4) Designations as to the proposed use of each lot and an indication of the types, location, and number of buildings and units proposed.

(d) Engineering Information

- (1) Proposed and existing locations for all proposed water mains, valves, water services, curb stops, meter pits, fire hydrants, booster pumping stations, treatment lines, storage tanks, storm and sanitary

sewers, laterals, clean outs and their accompanying manholes, inlets, culverts and appurtenances, including underground gas, electric, telephone and cable TV.

- (2) Sanitary sewers mains to be constructed as close to the centerline of the road as possible, and be a minimum of ten (10) feet off proposed or existing water mains or separated by a vertical clearance of 18 inches, sanitary line being lower, unless sewer pipe is ductile iron with mechanical or slip on joints, or sewer main is encased within concrete. In addition, one full length of sewer pipe should be located so both joints will be as far from the waterline as possible. Where a watermain crosses under a sewer, adequate structural support for the sewer shall be provided.
 - (a) If the sewer main crosses a storm sewer with 8 to 18" clearance between the utilities, the area between the utilities is to be choked with 3/8" stone. If there is less than 8" clearance between the utilities, the area between the utilities will be evaluated by the MTMUA and a recommended design will be required to be incorporated into the drawing documents.
 - (b) The height of a deep house connection is to be indicated on the profile. The height is from the invert of the sewer main to the invert of fitting at the top of the riser. The riser is to be designed such that there is 6" clearance with other utilities when taking into consideration the minimum slope of the lateral from the riser to the cleanout, the pipe diameter and the 6" clearance with other utilities.
- (3) Pipe sizes, types and strength classifications. Any sewer at a depth greater than sixteen feet from proposed grade to invert must be class 56 D.I.P. smooth wall (PVC lined) minimum or ribbed PVC sewer pipe from manhole to manhole. Marston calculations will be used for determining class of pipe. The applicant's engineer may propose to utilize other pipe material such as PVC C900

provided they provide the necessary calculations which prove the pipe deflection meets the MTMUA requirements.

- (4) Where proposed sewers cross under transite watermain, the transite pipe shall be removed from joint to joint to undisturbed ground 1-1/2' minimum beyond the sanitary sewer trench's angle of repose, and replaced with class 52 D.I.P. using Mueller split repair sleeves or approved equal or as directed by the Authority's Engineer.

Note: Existing watermain shut down must be coordinated forty-eight (48) hours in advance prior to shut down with the M.T.M.U.A. water department personnel.

- (5) Benchmarks referring to established USC&GS monuments, (NGVD 1988) shall be permanently established for the area and shall be located on each drawing sheet for sanitary facility and set at all pumping stations and treatment plant sites. Each application must be verified to a USC&GS monument, not to an elevation established by a previous application.
- (6) Spot elevations to the nearest 0.1 foot.
- (7) Finished first floor elevations at each unit.
- (8) Proposed contours of one (1) foot intervals for the whole tract.
- (9) Distances between manholes and slopes of sewers.
- (10) Arrows showing flow direction.
- (11) Manholes are to be provided at ends of sewer lines, intersections, grade changes and alignment changes. Where manholes are over 16 feet deep the base section of the manhole shall be 6 feet in diameter by a minimum 5 feet in height with a reducing section 3 feet high to 4 feet in diameter transition.

- (12) Distances between manholes not to exceed 400 feet for sewers 18 inches or less in diameter, 500 feet for sewers greater than 18" in diameter.
- (13) "Plan" and "Plan and Profile" drawings shall show:
 - (i) All existing and proposed utilities including water supply, sanitary sewers, storm drains, manholes, pumping stations and existing grades and proposed profiles.
 - (ii) Gradients, lengths, sizes, materials, and strength classifications of all pipes. Sewers shall be designed with the following minimum hydraulic slopes (grades producing velocities of greater than 10 feet per second are not recommended). Minimum acceptable "As-built" slopes are also shown below:

TABLE 1

PVC Pipe (Polyvinylchloride) Pipe Diameter (based on Kutter's or Manning's formula with N=0.010)	Fall in feet per 100 feet of sewer	
	(Minimum)	
	<u>As-Built</u>	<u>Design*</u>
8 inches.....	0.30	0.35
10 inches.....	0.20	0.25
12 inches.....	0.15	0.20
15 inches.....	0.10	0.15
18 inches.....	0.075	0.09
20 inches.....	0.065	0.07
21 inches.....	0.06	0.065
24 inches.....	0.05	0.055
27 inches.....	0.042	0.047
30 inches.....	0.035	0.04
36 inches.....	0.028	0.033

*Where manhole runs are 200 feet or less, the minimum design slopes should be increased by an additional 0.05 feet per 100 feet in order to allow for construction tolerances.

All other Pipe Material (based on Kutter's or Manning's

formula with $n=0.013$)

Pipe Diameter	Fall in feet per 100 feet of sewer	
	(Minimum)	
	<u>As-Built</u>	<u>Design*</u>
8 inches.....	0.40	0.45
10 inches.....	0.29	0.34
12 inches.....	0.22	0.27
14 inches.....	0.17	0.22
15 inches.....	0.16	0.21
16 inches.....	0.14	0.19
18 inches.....	0.12	0.17
20 inches.....	0.10	0.15
21 inches.....	0.095	0.10
24 inches.....	0.080	0.085
27 inches.....	0.067	0.072
30 inches.....	0.058	0.063
36 inches.....	0.046	0.051

*Where manhole runs are 200 feet or less, the minimum design slopes should be increased by an additional 0.05 feet per 100 feet in order to allow for construction tolerances.

- (iii) Top of casting elevations and 0.1 drop required across manhole sewer inverts at each manhole.
- (iv) Connections made into existing manholes shall be machine cored, and a Link-Seal by Thunderline Inc. with stainless steel hardware shall be installed as an approved watertight connection.
- (v) Inverts and stations of deep house connection laterals at sewer main.
- (vi) Clearances between pipe crossings.

- (vii) Standard drawing scales (1" = 50' Horizontal 1" = 5' Vertical minimum) on each sheet.
 - (viii) Sheets numbered consecutively.
 - (ix) An index of the streets shall also be shown on each sheet.
- (14) Plans for pumping stations shall include a general site plan showing boundaries and existing and proposed one (1) foot contours, pumping stations pumping unit capacities, proposed mechanical and piping plans, electrical plans, underground piping, underground and overhead wiring and other details necessary for review of the proposal. Automatic on-site standby power facilities and approved odor control facilities shall be provided.
- (15) Individual connections provided for each individual family dwelling shall be provided with a cleanout and protection box 2 feet behind the curblineline or edge of pavement or at the easement line. Under no circumstances shall cleanouts or manholes be allowed in pedestrian walkways or driveways. All sewer laterals shall be designed and constructed leaving the sewer main as close as possible to 90 degrees.
- (16) The plans and specifications must indicate provisions for landscaping, paved roads and walkways.
- (17) Any residential dwelling designed and constructed with sewer facilities in the basement or below ground elevation shall have its 4" lateral protected against sewer backups using a whole house check valve, in accordance with the National Plumbing Standards and be located in the basement for accessibility. The MTMUA will not be responsible for any backups for which the subject plumbing fixture was located below the elevation of the nearest MTMUA sanitary sewer manhole.
- (18) At crossings, ductile iron sewer or 6" minimum thickness of concrete encasement on sewer mains shall extend at least 10 feet either side of the watermain crossing when sewer main is above

watermain or when 18" clearance cannot be achieved. In addition, one full length of sewer pipe should be located so both joints will be as far from the water line as possible. Where watermain crosses under a sewer, adequate structural support for the sewer shall be provided.

(e) Facilities Outside the Township.

In the event that a proposal involves the use of a collection system lying entirely or partially outside of the Township limits, submission shall include comprehensive plans of all mains, treatment works, pumping stations, and all connecting appurtenances. Developer shall comply with all regulations and contractual obligations of the Authority which are applicable.

(f) Easements.

Easements are to be avoided wherever possible. All required easements to be deeded to the Authority shall be clearly indicated on the drawings. Easements shall be unencumbered, restricted to water/sewer utilities only and shall be a minimum of twenty (20) feet. Description of easements shall be metes and bounds along centerline of pipe with 10' minimum on either side. The description shall be in the form of a map and metes and bounds description. The POB (point of beginning) shall be tied to an existing surveyed point, bearings and distances should be described in words and numeric characters. All turning points shall be labeled with their corresponding N.J. State Plane Coordinate (northing, easting) consistent with NAD '83 horizontal datum. Where sanitary sewers are to be installed in streets which will not be dedicated to the Township of Monroe, the County of Middlesex or State of New Jersey, the easement width shall be the entire width between the curb lines, plus 10 feet on either side. A deed in recordable form satisfactory to the Authority shall be submitted with an application for Final Approval. (See Section S:15i, Form S9, Deed of Easement). For above ground installations, a fee simple title is required.

g. Specifications for the Construction of Sewer Facilities.

Two copies of complete specifications for the construction of the proposed sewerage system and appurtenances, including sewage

pumping stations and treatment plants, shall accompany the plans marked "Tentative".

h. Details of Construction.

Two copies of construction details shall accompany the plans. Details shall be drawn to standard scales to show clearly the nature of design marked "Tentative".

i. Fees.

The proper review fee for review of the application shall be based on the review fee schedule attached under "Tentative".

j. Attend Meetings.

The applicant should appear at a regularly scheduled M.T.M.U.A. agenda meeting for discussion of the project.

S:4-3 Application for Final Approval of Plans for Sewer Systems.

a. Application to Authority.

1. Final Application Forms:

Upon notification by the Authority that Tentative approval has been given to the proposed sewer system with its appurtenances, or that all conditions of Tentative approval have been satisfied, the applicant may file an application for Final approval of plans and specifications and for authorization to proceed with construction.

This application will be filed, in duplicate, on a form furnished by the Authority.

2. Engineer's Estimate of Construction Cost:

Four (4) copies of the approved Tentative Engineer's estimate labeled "Final".

3. Engineer's Report:

Four (4) copies of the approved Tentative Engineer's report labeled "Final".

4. Overall Map: Paper and Digital. Digital copies shall meet or exceed the requirement of NJDEP Mapping and digital standards.

Four (4) copies of the approved Final general map, marked "Final".

5. Plans and Profiles: Paper and Digital. Digital copies shall meet or exceed the requirement of NJDEP Mapping and digital standards.

Four (4) copies of the approved Final Plans and Profiles.

6. Specifications:

Four (4) copies of the approved Final specifications.

7. Details of Construction:

Four (4) copies of the approved Final details of construction.

8. Approval of Plans by State and County Agencies and Others:

- (a) Where necessary, approval of plans for construction and operating permit by the New Jersey Department of Environmental Protection (N.J.D.E.P.) or other agencies will be required by the Authority as a condition of the Authority's Tentative approval. The applicant shall obtain permits for all stream crossings, wet lands or encroachments from the N.J.D.E.P. Division of Water Resources, where required. Permits to construct sewer mains or other structures within the right-of-way limits of State, County, Municipal Roads and all Railroads must be secured and paid for by the applicant.

- (b) The applicant must also secure any necessary permits or clearances from any public utilities or agencies involved.

- (c) The applicant must have written proof of correct lot and block numbers from the Township prior to requesting the M.T.M.U.A. signing off on same.

9. Performance Guarantee:

Performance Guarantees shall be in a form acceptable to the Authority's attorney and shall be in the amount of one hundred twenty (120%) percent of the total construction cost as defined under "Engineer's Estimate of Construction Cost". It shall be furnished guaranteeing complete construction within the time period to be specified by the Authority and further guaranteeing that said construction will be in accordance with the Rules and Regulations of the Authority, and the Plans and Specifications, Engineer's Report and Cost Estimates are approved by the Authority. The guarantee may be either:

- (a) 10% cash and 90% acceptable bond or Letter of Credit or
- (b) 100% Letter of Credit

10. Fees:

- (a) Application fees shall be based on the latest fee schedule.
- (b) Review fees shall be based on the latest fee schedule.
- (c) Inspection fees shall be based on the latest fee schedule.

For those developments for which the reasonably anticipated inspection fees are less than \$10,000, fees may, at the option of the developer, be paid in two installments. The initial amount deposited by a developer shall be 50% of the reasonably anticipated fees. When the balance on deposit drops to 10% of the reasonably anticipated fees because the amount deposited by the developer has been reduced by the amount paid to the Staff Engineer for inspection, the developer shall deposit the remaining 50% of the anticipated inspection fees. For those developments for which the reasonably anticipated fees are \$10,000 or greater, fees may, at the option of the developer, be paid in four installments. The initial amount deposited by a developer shall be 25% of the reasonably anticipated fees. When the balance on deposit drops to 10% of the reasonably anticipated fees because the amount deposited by the developer has been reduced by the amount paid to the Staff Engineer for inspection, the developer shall make additional deposits of 25% of the reasonably anticipated fees. The Staff Engineer shall not perform any inspection if sufficient funds to pay for those inspections are not on deposit.

- (d) Connection fees (as set forth in the Authority's current rate schedules) shall be applied as follows:
 - (1) In the case of real estate developers the connection fees for the development shall be payable at the time of final approval.
 - (2) In any development of more than ten (10) but less than forty (40) units, connection fees for twenty-five percent (25%) of the units shall be payable at the time of final approval with the balance of connection fees payable in advance of actual connection.

- (3) In any development of more than forty (40) units, connection fees for the first ten (10) units shall be payable at the time of final approval with the balance of connection fees payable in groups of ten (10) units at a time in advance of the actual connection.
- (4) For users other than residential, connection fees (as set forth in the Authority's current rate schedules) shall be calculated by using the Engineer's estimate based on N.J.D.E.P. Standards of sewage average daily flow, and dividing it by the Equivalent Dwelling Unit or E.D.U. and multiplying the E.D.U. by the connection fee amount set forth in the schedule.
- (5) If a non-residential applicant wishes to estimate usage based on other than D.E.P. standards, the Authority may permit it, provided the applicant enters into a written agreement allowing the Authority to monitor the actual flow and assess additional connection fees, at the then current rate, for increases in flow above the original estimate.
- (6) Where an Engineer's estimate is not available the applicant will use published N.J.D.E.P. Standards and apply it to the formula mentioned above.

11. Easements:

For all lands other than public right of ways, Deeds of Easement fully executed in accordance with Section S:15i, Form S9, Deed of Easement, shall be submitted. They shall be accompanied by metes and bounds descriptions with drawings signed and sealed by a licensed land surveyor. All easements will be recorded by the MTMUA, not the applicant.

12. Attend Meetings:

The applicant should appear at a regularly scheduled Authority agenda meeting.

S:4-4 Application for Individual Sewer Connection.

- a. Property owners desirous of making connection to existing sewer mains, shall file an application for sewer connection with the Authority on a form

furnished by the Authority. This application shall be accompanied by the appropriate connection fees as set forth in the Authority's current rate schedule. The applicant shall also be responsible for the construction of the sewer tap. Connection shall be made to an existing street main at the expense of the applicant with inspection by the Authority. Connection to the sewer main shall be made in accordance with the Authority's Construction Details, Appendix A, as amended.

- b. A house service connection shall be defined as the pipe and appurtenances between the Authority's street main and the individual curb cleanout, including the cleanout. Connections beyond the curb cleanout assembly are under the jurisdiction of the Township Construction Office Plumbing Inspector whose approval will be required before the Authority will service the facility.
- c. Any residential dwelling designed and constructed with sewer facilities in the basement or below ground elevation shall have its 4" sewer lateral protected against sewer backups using a whole house check valve in accordance with the National Plumbing Standards. The MTMUA will not be responsible for any backups for which the subject plumbing fixture was located below the elevation of the nearest MTMUA sanitary sewer manhole.

S:4-5 Revised Application.

Whenever there is substantive change in the configuration of the system and/or revision of the road pattern, and/or any offsite change related to the project or section proposed, then a revised application for the previous stage of approval is required.

S:4-6 Application for Extension of Approval.

If an approval has become null and void as per Section S:4, the applicant may apply for an extension of approval. He shall attend the M.T.M.U.A. meeting to explain the reasons necessitating an extension.

S:5 DETAILED INFORMATION ON DESIGN AND CONSTRUCTION OF SEWERAGE SYSTEMS.

- a. Preamble.
 1. Materials used in the construction of sewers, force mains, and outfalls shall be as follows: gravity sewers shall be constructed of

reinforced concrete, ductile iron, cast iron, or ribbed or smooth wall polyvinyl chloride. Force mains shall be constructed of cast iron, ductile iron pipe or PVC C-900 or C-905 unless otherwise permitted by the Authority. (Revised 1-16-03)

2. All references to standard specifications A.S.T.M., A.N.S.I., and the like, shall be of the latest revision thereof.
3. Before any field changes are made, the design engineer shall revise drawings and submit copies to the Authority for approval. Three (3) copies of the approved drawings shall be submitted to the M.T.M.U.A. prior to construction.

S:5-1 Specifications.

a. General.

1. The applicant's contractor shall provide all labor, pipe, fittings, gaskets, manholes, accessories, and other materials, equipment, special services, and all else necessary to furnish, install, and provide complete, in place, all sewer mains and appurtenances as required by the plans and specifications or as required in order to fulfill the intent of same. All work and materials shall conform to the requirements of the Utilities Authority Rules and Regulations.
2. This specification includes the construction of sewer mains and appurtenances at the locations shown on the plans and shall include performing all operations in connection with the installation of all pipe, fittings, gaskets, manholes, accessories and other materials, and connections to existing and new piping, manholes and concrete encasement, bedding, trenching, backfilling, accessories, appurtenances, miscellaneous work, and the testing of the entire new system.
3. The quality of all materials, manufacturing procedures, and the finished pipe shall be subject to inspection and approval of the Engineer. Such inspection may be made at the place of manufacture and/or at the work site after delivery, and the pipe shall be subject to rejection at any time on account of failure to meet any of the specification requirements, even though sample pipes may have been accepted as satisfactory at the place of manufacture.

b. Condition of Site.

1. A complete set of pre-construction videos of the areas adjacent to the proposed work must be made by the applicant's contractor.

Any post-construction damage not clearly shown in the pre-construction videos will be assumed to have been caused by the construction, so the contractor is advised to carefully document all pre-construction conditions adjacent to the work (i.e., curbs, sidewalks, foundations, etc.)

2. The applicant's Contractor shall protect and take care of all work until final completion and acceptance thereof. During construction, the applicant's Contractor shall keep the site free and clean from all rubbish and debris and in a sanitary condition, and shall promptly clean up the site after being notified by the Authority.
3. All work shall be confined to the applicant's site and/or right-of-ways existing easements. If property owned by other than the owner is disturbed it shall be restored to at least as good a condition as prior to disturbance as soon as the work is completed. The M.T.M.U.A. may order a halt of construction until such restoration is effected.
4. After completion of the work and before application for acceptance of the work, the applicant's contractor shall clean the site of the work and all ground and property that has been occupied or used by him in connection with the work, removing all rubbish, surplus materials, false work, temporary structures, and equipment, and all parts of the work shall be left in a neat, presentable and operable condition.

c. Protection of Traffic.

All streets and roads used shall be kept free from dust. Unless permission to close certain streets or roads is obtained from the Monroe Township Council, at least one-half of the width of each street or road shall be kept open to traffic at all times.

d. Storm and Waste Water.

The applicant's contractor shall take care of storm water and waste water reaching the right-of-way from any source and shall prevent damage to property on or off the right-of-way due to interruption or diversion of such storm or waste water on account of his/her operations.

e. Standard Practices.

1. Water mains and sewers shall be installed in separate trenches and separated by a horizontal distance of 10 feet. Where they cross they shall be separated by a vertical clearance of 18 inches,

sanitary line being lower, unless sewer pipe is cast iron with mechanical, or slip-on joints, or sewer main encasement provided.

2. Sewer mains shall be separated from drainage pipes a minimum of 18 inches. If clearance is between 8" –18", then the area between pipes shall be chocked with 3/8" clean stone.
3. If mains, fittings, and appurtenances are to be installed in an area that has been previously excavated for water mains or storm drains, the backfill beneath the water facilities shall be backfilled to 95% Modified Proctor Density and so certified by a soils lab acceptable to the Authority. If clean stone is used in the trench for dewatering instead of choked stone blend, the clean stone shall be encapsulated in suitable approved geotechnical filter fabric.
4. If sewer mains, fittings and appurtenances are to be installed in an area that has been previously excavated for sanitary sewers or storm drains, the backfill beneath the water facilities shall be backfilled to 95% Modified Proctor Density and so certified by a soils lab acceptable to the Utility.
5. If clean stone instead of choked stone blend is used in the trench for control of groundwater, the clean stone shall be encapsulated in suitable approved geotechnical filter fabric.

S:5-2 Construction of Sewer System.

All construction, materials, methods, etc. shall conform to the following requirements of Monroe Township Municipal Utilities Authority Rules and Regulations for Proposed Sewerage Systems, Section S:5-2 through Section S:5-25.

S:5-3 Reinforced Concrete Pipe - Only for Pipes > 24" Diameter.

- a. Concrete pipe shall meet all the requirements of the A.S.T.M. Specification C76, Wall B.
- b. Reinforced concrete pipe joints shall be the steel and rubber gasketed joint as described in Gifford-Hill American specification SP-32, and as manufactured by Gifford-Hill American, Price Brothers or equal.
- c. Rubber and steel joints shall be externally mortared after jointing. In no case shall pipe with a strength classification of less than Class IV be permitted. For depths less than three feet, measured from top of the pipe, installed under traffic areas, Class V pipe shall be required.

- d. Non-residential developments can use a minimum of Class III R.C.P. and, in the case of depths less than 3 feet in a traffic area, Class IV. In any event, a Marston calculation shall be performed to determine the proper class of pipe dependent on loading conditions.

S:5-4 Ductile Iron Pipe.

- a. Ductile iron pipe shall be centrifugally cast in metal or sand molds in accordance with A.N.S.I. Specification A21.51, minimum thickness Class 52 unless otherwise required. The joint shall conform to the requirements of A.N.S.I. A.21.11 and shall be of a type that employs a single elongated groove gasket to effect a joint seal such as United States Pipe Company's "Tyton" joint, James B. Clow and Sons, Inc. "Bell-tite", or equal. Gaskets shall be of a composition suitable for exposure to sewage.
- b. The outside of the pipe shall be coated with a uniform thickness of a hot applied coal tar and the inside of the pipe shall be lined with PVC or similar smooth wall material.
 - 1. Testing:

Force Mains, Fittings and Appurtenances - Hydrostatic and leakage tests required. Gravity Sewers and Fittings - Low air pressure tests in accordance with Section S:6-2e, Table II.

S:5-5 Cast Iron Pipe.

- a. Cast iron (pit cast) house connection pipe and fittings shall be extra heavy thickness conforming with the requirements of A.N.S.I. Specification A74.
- b. Neoprene gasket joints shall conform to A.S.T.M. C-564. Lead and oakum joints shall be made in accordance with A.W.W.A. Standard C-600.
 - 1. Testing:

Force Mains, Fittings and Appurtenances - Hydrostatic and leakage tests required.

Gravity Sewers and Fittings - Low air pressure tests in accordance with Table II, Section S:6-2e,. Lamp and mandrel testing.

S:5-6 Ribbed PVC Sewer Pipe.

- a. Pipe shall be Polyvinyl Chloride (PVC) ribbed sewer pipe with an integral bell and spigot type rubber gasketed joint. Each spigot end shall be complete with a single rubber gasket. All fittings furnished with the ribbed pipe shall be made from smooth wall SDR 35 pipe to ribbed pipe sealing dimensions. The rubber gasket shall be pretensioned around the spigot of the pipe and inserted into a smooth bell to provide a tight joint in compliance with ASTM-D3212.
- b. Pipe shall have a smooth interior with a solid cross sectional, integrally extruded, rib exterior. Exterior ribs shall be perpendicular to the axis of the pipe to allow placement of the sealing gasket without additional cutting or machine.
- c. Ribbed PVC gravity sewer pipe shall meet the requirements of ASTM F794 "Standard Specification for Polyvinyl Chloride (PVC) Ribbed Gravity Sewer Pipe and Fittings Based on Controlled Inside Diameter" and Uni-Bell UNI-B-9 "Recommended Standard Performance Specification for Polyvinyl Chloride (PVC) Profile Wall Gravity Sewer Pipe and Fittings Based on Controlled Inside Diameter".
- d. Each length of pipe shall be marked with size, company name or logo, PVC sewer pipe, ASTM F794 - '91 manufacturer's code, cell classification.
- e. Ribbed PVC sewer pipe shall have a minimum pipe stiffness (F/Y) of 60 PSI in sizes 8" - 12" and 46 PSI in sizes 15" - 30" when tested in accordance with ASTM D-2412.
- f. All fittings shall utilize rubber gasketed joints and be compatible with that of the pipe, and be manufactured by H.A.R.C.O., the Harrington Corporation, and meet the deep bell and minimum cross section requirements stipulated in Section S:5-7.
- g. The pipe shall be located and installed to the lines and grades shown on the drawings.
- h. References.

ASTM D618 Methods of conducting plastics and electrical insulating materials for testing.

ASTM D883 Definitions of terms relating to plastics.

ASTM D1784 Specification for rigid polyvinyl chloride (PVC) compounds and chlorinated polyvinyl chloride (CPVC) compounds.

ASTM D2122 Methods of determining dimensions of thermoplastic pipe and fittings.

ASTM D2152 Test method for degree of fusion of extruded polyvinyl chloride (PVC) pipe and molded fittings by acetone immersion.

ASTM D 2321 Practice for underground installation of flexible thermoplastic sewer pipe.

ASTM D2412 Test method external loading properties of plastic pipe by parallel-plate loading.

ASTM D2444 Test method for impact resistance of thermoplastic pipe and fittings by means of a tup (falling weight).

ASTM D2855 Practice for making solvent-cemented joints with polyvinyl chloride (PVC) pipe and fittings

ASTM D3034 Specification for Type PSM polyvinyl chloride (PVC) sewer pipe and fittings.

ASTM D3212 Specification for joints for drain and sewer plastic pipes using flexible elastomeric seals.

ASTM F402 Practice for safe handling of solvent cements and primers used for jointing thermoplastic pipe and fittings.

ASTM F412 Definitions of terms relating to plastic pipe systems.

ASTM F477 Specification for elastomeric seals (gaskets) for joining plastic pipe.

ASTM F794 Standard specification for polyvinyl chloride (PVC) ribbed gravity sewer pipe and fittings based on controlled inside diameter.

i. Materials.

1. Ribbed PVC sewer pipe shall be made of PVC material having a cell classification of 12454-B, 12454-C, or 13364-B as defined in ASTM D1784

"Specifications for Rigid Polyvinyl Chloride (PVC) Compounds and Chlorinated Polyvinyl Chloride (CPVC) Compounds".

2. Pipe and fittings shall be homogenous throughout and free from cracks, holes, foreign inclusions, or other defects. The pipe shall be as uniform as commercially practicable in color, opacity, density, and other physical properties.
3. There will be no evidence of splitting, cracking or breaking when pipe is flattened by 60% of its outer diameter between parallel plates.
4. Pipe shall not disintegrate or flake when tested in accordance with ASTM D2152 "Test for Quality of Extruded Polyvinyl Chloride Pipe by Acetone Immersion".
5. The impact resistance of ribbed PVC sewer pipe shall meet the requirements shown below when tested in accordance with ASTM

D2444 "Test for Impact Resistance of Thermoplastic Pipe and Fittings by Means of a Tup (Falling Weight)".

8" 210 FT/LBS.

10" - 30" 220 FT/LBS.

6. The minimum "pipe stiffness" ($F/\Delta Y$) at 5% deflection shall be 60 PSI for 8" - 18' when tested in accordance with ASTM D2412 "External Loading Properties of Plastic Pipe by Parallel-Plate Loading". The minimum "pipe stiffness" ($F/\Delta Y$) at 5% deflection shall be 46 PSI for 21" - 30" when tested in accordance with ASTM D2412.

j. Handling and Storage.

Handle pipe and fittings with care to prevent damage. Store pipes on flat surfaces so the barrels are evenly supported. If materials are stored outside for an extended period of time, cover with opaque material to protect from direct sunlight.

k. Jointing and Installing.

1. Pipe and fittings shall be installed in accordance with the manufacturer's recommendations and as specified in ASTM D 2321.
2. Field cut pipe shall have square cut ends and shall be cut between ribs.
3. Pipe bedding shall have a minimum thickness as shown on the drawings.
4. Haunching material shall be placed to the spring line of the pipe and compacted by hand adjacent to the pipe. Sufficient material shall be worked under the haunch of the pipe to provide adequate side support. Precautions shall be taken to prevent movement of the pipe during placement of the haunch.
5. Material for initial backfill shall be as shown on the drawings. Initial backfill shall be placed in two (2) stages. The first stage shall be to the top of the pipe. The second stage shall be to a point at least twelve inches (12") over the top of the pipe.

l. Measurement.

Measurement of pipe and fittings is on a linear foot basis measured centerline to centerline of manholes except where the pipe enters a structure other than a manhole.

m. Testing.

Gravity Sewers and Fittings - Low air pressure test in accordance with Section S:6-2e, Table II, Lamp and mandrel..

S:5-7 Smooth Wall Polyvinyl Chloride Pipe.

- a. Plastic pipe shall be polyvinyl chloride sewer pipe with bell and spigot ends, O-Ring rubber gasketed joints shall conform to ASTM D-3212. Plastic pipe and fittings shall conform to ASTM D-3034 - latest revision, with a wall thickness designated of SDR 35 (minimum) as defined in Section 7.4.1. Fittings in sizes through 8" shall be molded in one piece with elastomeric joints and minimum socket depths as specified in Sections 6.2 and 7.3.2. Fittings 10" and larger shall be molded or fabricated in accordance with Section 7.11 with manufacturers standard pipe bells and gaskets. PVC material shall have a cell classification of 12454-B or C as defined in ASTM D-1784.
- b. The material from which the pipe and fittings are extruded shall be high impact types of PVC, unplasticized having high mechanical strength and maximum chemical resistance conforming to Type I, Grade 1, of the specification for rigid polyvinyl chloride compounds, ASTM D-1784, latest edition.
- c. Pipe shall be free from defects, bubbles and other imperfections in accordance with accepted commercial practice. The adequacy of the pipe gasketed joint shall be demonstrated, if required, by a test at the manufacturing plant in accordance with ASTM D-2444 for impact and ASTM D-2412 for Deflection and Pipe Stiffness, latest revisions.
- d. Rubber ring gaskets shall be manufactured as per ASTM F-477 latest revision. The gasket shall be the sole element depended upon to make the joint watertight and have a minimum cross sectional area of 0.20 sq. in.
- e. The applicant shall submit for approval, details of the pipes, joints, fittings, beddings, etc., which he intends to use. The applicant shall arrange for such tests as the Engineer may require sufficiently in advance that the work will not be delayed. All cost associated with the performance of such tests shall be borne by the applicant.

- f. The pipe shall be installed as specified in ASTM designation D-2321, latest revision. In no case shall less than a Class III material be used for bedding and haunching material unless approved in writing by the Engineer. Particular attention should be given to the special requirements for installing pipe in unstable soil or excessive ground water. Any additional cost for materials used under these trench conditions is to be borne by the applicant.
- g. The maximum length of 4" PVC piping shall be 12.5'.
- h. Testing.

Gravity Sewers and Fittings - Shall be low air pressure tested in accordance with Section S:6-2e, Table II.

S:5-8 Vitrified Clay Pipe.

- a. Pipe shall be manufactured from fire clay, shale, surface clay, or a combination of these materials that, when formed into pipe and fired to suitable temperature, yields a product that conforms to these specification references ASTM-C301, C425, C700, C828, C896, and C1091. The joint shall conform to the requirements of ASTM C-425-96 and shall be of a compression rubber type located in a groove on the spigot end of the pipe which compresses upon installation into the bell end of either a similar pipe or fitting. Sealing elements shall be compressed between bearing surfaces to assure watertight integrity as required in ASTM Section 7 of C425. Sealing elements shall either be bonded to bearing surfaces or be independent elements as required in ASTM C425 and in accordance with all reference documents.
- b. Testing.

Gravity Sewer and Fittings - Shall be low air pressure tested in accordance with Sections S:6-2h through S:6-2o, Tables III to X.

Force Mains, Fittings and Appurtenances - Hydrostatic and leakage tests required. Where PVC pipe is utilized, the trace wire must be tested for continuity.

S:5-9 ABS Laterals And Clean Outs.

- a. Pipe shall be manufactured, design, installed and tested in accordance with ANSI/AWWA Standards, D1084, D1600, D1784, D2235, D2241, D2564, D2661, D2665, D3138, F402, F412, F493.

b. Testing.

Gravity Sewer and Fittings - Shall be low air pressure tested in accordance with Section S:6-2e, Table II.

S:5-10 Pressure PVC Pipe 4" to 30".

Pressure PVC pipe, appurtenances, fittings, design, manufacturing, tapping, testing and installation shall conform to ANSI/AWWA Standards C600, C605, C900, C901, C905, C909, M23, M17, M31 and ASTM Standards F1483, D2241, D1598, D1599, D2239, D2237, D2837, D3035, D3350, F412, D2774, D2487, D1784, D3139 and UNI-B-9. (All PVC pressure pipe used for sewage force mains shall have a minimum DR-18 requirement.) Where PVC pipe is used, a trace wire detection (8 gauge, coated) shall be supplied. Continuity test of trace wire is required before final acceptance.

S:5-11 Hydrostatic Testing - Force Mains.

All pressure sewer pipe shall be hydrostatically tested in accordance with AWWA 600. The pipe shall be cleaned, filled and remain filled with water for a period of at least twelve hours. After absorption is complete, the pipe, valves, and appurtenances shall be tested under a pressure equal to twice the maximum possible pressure or 150 PSI, whichever is greater. No leakage will be permitted over a two hour period. All valves, air release assemblies, and blow off assemblies shall be independently tested by sections of the tested forcemain valve to valve to various assemblies. The applicant's contractor shall furnish all labor, material, and equipment necessary for the testing. Any new pipe, joint, or other part of the sewer forcemain whether PVC or DIP found to show leakage shall be removed and replaced.

S:5-12 Pipe Bedding and Trenching.

a. Method of Construction.

1. Excavation.

Prior to any excavation, notice shall be given to Monroe Township Municipal Utilities Authority 48 hours in advance. The developer shall locate and mark all existing utilities and structures in the vicinity of, or intersecting the proposed sewers. The developer shall be responsible for the continuity of such services affected by his/her operation, and shall maintain them in a safe and satisfactory operating condition. The developer or his/her

contractor shall apply for all local, state and county road opening permits in advance and having those approval permits in hand prior to excavation or cutting of roadways.

2. Excavation and Preparation of Trench.

(a) Underground Utilities and Structures.

It shall be the applicant's contractor's responsibility to contact the utilities companies involved and to locate existing structures. Underground drains, electrical lines, sprinklers or other underground improvements in the public rights-of-way shall be maintained in service by the contractor during construction, and restored, after construction is complete, to at least the condition prior to construction. As the excavation approaches pipes, conduits, or other underground structures, digging by machinery shall be discontinued and the excavation shall be done manually. The trench in which the sewers and appurtenances are to be constructed shall be opened in accordance with the indicated grades or as approved by the M.T.M.U.A. All excavation shall be open cut from the surface except where otherwise directed, and shall be excavated to the limits shown on the Trench Detail drawing or as directed to provide suitable room for construction operations.

(b) Length of Open Excavation.

Open excavation shall not exceed 200 feet in length at any time. Pipe laying, inspection and backfilling shall be coordinated with excavation to minimize the amount of open trench remaining unfilled at the end of the day. The M.T.M.U.A. shall have the right to stop excavating operation where pipe laying and backfilling do not keep pace with excavation.

(c) Backfill Material.

(1) Unsuitable material at or below trench invert as shown on the drawings shall be removed as the M.T.M.U.A. may approve and backfilled with select material I-2 (NJ DOT) when suitable on site material is not available.

(2) The applicant may provide, as an alternate, a written recommendation from a licensed professional engineer as to suitability of on-site

backfill material, its emplacement and compaction or suitable off-site backfill and its method of installation.

(d) Trench Width.

The trench width at the ground surface may vary with and depend upon its depth and the nature of the ground encountered in accordance with current O.S.H.A. regulations and Confined Space Entry requirements. The minimum clear width of unsheeted or sheeted trench measured at the horizontal diameter of the pipe shall be one foot greater than the outside diameter of the barrel of the pipe. Maximum clear width of trench at the top of the pipe shall be not more than outside of the barrel of the pipe plus two feet. Greater width of trench at the top of the pipe shall be permitted only on written approval by the Design Engineer and the Authority.

(e) Blasting.

Blasting for excavation will be permitted only after securing approval of the Design Engineer and the Authority and only when proper precautions are taken for the protection of person and property. The hours of blasting will be fixed by the Authority. Any damage caused by the blasting shall be repaired by the applicant at his/her expense. The applicant's procedures and methods of blasting shall conform to local laws and municipal ordinances, and all applicable State and Federal regulations.

(f) Maintenance of Site.

The applicant shall also remove pavement as stipulated; excavate the trenches and pits to the required dimensions; excavate the bell holes; construct and maintain all bridges for traffic control; sheet, brace, and support the adjoining ground or structure where necessary; handle all drainage or ground water; provide barricades, guards and warning lights; lay and test the pipe, fittings and accessories; backfill and consolidate the trenches and pits; restore the site; remove surplus excavated materials; clean the site of the work; and maintain the street or other surface over the trenches as specified.

(g) Storage of Excavated Materials.

All excavated material shall be piled in a manner that will not endanger the work and/or workmen and will avoid obstructing sidewalks and driveways. Ramps, shoulders and access roads shall be kept clear or other satisfactory provisions shall be made for street drainage and safe crossings.

(h) Trench Digging Machinery.

The use of trench-digging machinery will be permitted except where its operations will cause damage to trees, buildings or existing structure above or below the ground. At such locations hand methods shall be employed to avoid such damage.

(i) Construction Signs, Barricades and Lights.

To protect persons from injury and to avoid property damage, adequate barricades, construction sign, torches, warning lights, and guards as required shall be placed and maintained during the progress of the construction work and until it is safe for traffic to use. When trenches are cut through any traveled way, watchmen shall be provided to prevent accidents.

(j) Accessibility of Driveways, Hydrants.

Excavations pipe laying operations shall be conducted to cause the least inconvenience for the general public. The applicant shall provide suitable bridges at street and driveway crossings where traffic must cross open trenches. Hydrants under pressure, valve pit covers, valve boxes, curb-stop boxes, fire or police call boxes, or other utility controls shall be unobstructed and accessible during the construction period.

(k) Water Flow.

Adequate provisions shall be made for the flow of sewers, drains and water courses encountered during construction. The structures which may have been disturbed shall be satisfactorily restored by the applicant.

(l) Excavation to Bedding Layer.

Trenches in stable soil shall be excavated to the bottom of bedding layer, as shown on the plans. If ledge rock,

boulders or large stones are encountered, they must be removed to prevent protrusion into the bedding.

(m) Bell Holes.

Bell holes shall be excavated in the bedding material to allow for unobstructed joint assembly. The holes shall be carefully filled with bedding or haunching material subsequent to making the joint to furnish adequate support of the pipe along its entire length.

(n) Trench Dimensions.

Trench dimensions, maximum depths, and bedding requirements (including cradles and encasement) for sewers, laterals, etc. shall be in accordance with the manufacturer's recommendations and as a minimum shall conform to the details shown on the Sewerage System Detail Drawings included as part of these Rules and Regulations.

(o) Bedding Details.

The applicant's application for Tentative review by the Authority shall include bedding details including reinforcing bar schedules for concrete cradles where applicable. All PVC sewer pipe shall be bedded with 6" of 3/8" clean stone below and 1' above and along sides as required.

(p) Ribbed PVC Pipe.

When ribbed PVC pipe is used in trench depths greater than 16 feet, clean 3/8" crushed stone shall be used 6" below ribbed pipe to 1 foot above ribbed pipe and along sides of pipe as required in the trench width schedule on the drawings.

3. Sheeting and Bracing.

The sides of all trenches shall be securely supported as required by the Code of the State of New Jersey and the Federal Occupational Safety and Health Act (OSHA) including Confined Space Entry requirements. All pertinent and applicable requirements shall be complied with, except as otherwise approved herein or by the Township. When, in the opinion of the Township, sheeting or bracing cannot be safely removed, it shall be left in place. Removable trench boxes or shields shall not be used where compaction of the backfill to minimum specified

densities is required unless approved in writing by the M.T.M.U.A. These trench boxes or shields shall be designed by a N.J. Professional Engineer in accordance with current O.S.H.A. standards.

4. Dewatering of Trench.

- (a) All pipes shall be laid on a solid, dry foundation. The applicant's contractor shall furnish all equipment, material and labor necessary to keep all trenches free from water to 1 foot below invert of pipe. Any pipe laid in water or wet trenches must be removed and reinstalled by the applicant's contractor.
- (b) The applicant's contractor shall provide, maintain and operate such drains, percolation stone, trenches, sumps, pumps, hoses, piping, deep wells, well-point systems, and other approved methods and equipment as may be necessary to keep the excavations free from water during all stages of the construction operations and course of work. Where dewatering is required after working hours, overnight or weekends all pumps shall be electrically operated from commercial power lines. No diesel or gasoline operated generators or pumps will be allowed in these situations unless approved in writing by the M.T.M.U.A..
- (c) The applicant's contractor shall provide such dikes, ditches, sumps and pumping that may also be required to prevent the flow of surface waters into excavated areas and into any and all areas where construction or installations are in progress. All water pumped from the excavation shall be discharged in such manner as shall not cause injury to work completed, damage to property, health hazards or impediment to traffic. Surface runoff, water from the trench, or water diverted from any sewer, drain or water course shall be conveyed in conformance with N.J. State Soil Conservation Committees' "Standards for Soil Erosion and Sediment Control in New Jersey" Dewatering permits required by N.J.D.E.P. shall be obtained by the developer.
- (d) Water shall be completely removed from all excavations to one foot below invert of pipe promptly and continuously throughout the progress of the work and the applicant's contractor shall keep excavations absolutely dry at all times until the water mains have been properly joined and

bedded and work completed. Precautions shall be taken to protect uncompleted work from flooding during storms or from other causes.

- (e) Where groundwater is encountered, the Staff Engineer and/or Authority inspector may require at their discretion, that the contractor install "clay stops" piped to drainage structures in order to prevent groundwater from following along the length of sewer pipe stone bedding.

5. Handling of Pipe.

- (a) The applicant shall, unless otherwise specified, furnish all material, equipment, tools, and labor necessary to do the work required under this standard and unload, haul and distribute all pipe fittings and accessories. Unloading of pipe from the delivery vehicle shall be done in accordance with manufacturer's installation guide. Pipe shall not be handled with chains or cables unless pipe is delivered with frames suitable for such lifting. Pipe may be unloaded manually, one pipe at a time. Pipe shall not be acceptable if dropped or damaged by unloading. Pipe shall be stacked in accordance with manufacturer's recommendations.
- (b) Proper implements, tools and facilities satisfactory to the Engineer shall be provided and used by the applicant for the safe and efficient execution of the work. All pipe fittings and accessories shall be carefully lowered into the trench using suitable equipment in such manner as to prevent damage to pipe and fittings. Under no circumstances shall pipe or accessories be dropped or dumped into the trench.
- (c) All foreign matter or dirt shall be removed from the interior of pipe before lowering into position in the trench. Pipe shall be kept clean by means approved by the Engineer during and after the laying.

6. Alignment and Grade.

- (a) Pipe shall be placed in the location and to the lines and grades shown on the drawings. No deviation shall be made from the required line or grade except with the written consent of the M.T.M.U.A. The M.T.M.U.A. shall have the authority to order the removal or relaying of any pipe laid contrary to final approved plan. 8" PVC pipe to be placed at a grade of not less than 0.30%, all other pipe

material at 0.40%, and shall be placed by use of a laser grade instrument.

- (b) Where the grade or alignment of the pipe is obstructed by existing utility structures such as conduits, ducts, pipes, service connections to water mains, or drains, the obstruction shall be permanently supported, relocated, removed or reconstructed by the applicant in cooperation with owners of such utility structures, or the pipe shall be constructed in a manner to avoid such obstruction, maintaining the alignment shown on the Plans.

7. Water Lines.

- (a) The sewer shall not be closer horizontally than a full ten feet separation distance to a water-supply line. Where gravity-flow sewers cross above water lines and where the minimum clearance between waterlines and sanitary sewers as stated above is not possible, the sewer pipe for a distance of ten feet on each side of the crossing shall be fully encased in concrete. The thickness of the concrete encasement, including that at the pipe joints, shall be not less than nine inches.
- (b) Prior to connecting new sewer construction to the existing collection system, the existing system shall be isolated by means of a test plug and masonry bulkhead, which will not be removed until the M.T.M.U.A. approves.

8. Laying and Joining the Pipe.

- (a) Before being set in place, each component of piping shall be inspected for damage and cleaned. Damaged components shall be reject or repaired. Pipe bells shall be laid on the upstream end. Sewer laying shall commence at the lowest elevation and shall terminate only at manholes, service branches or clean outs. Trenches shall be dewatered, if necessary. Whenever pipe laying is interrupted, the end of the pipe shall be temporarily plugged to prevent the entrance of water, mud, or foreign matter, and the pipe shall be secured to prevent its being dislodged.
- (b) Pipe and fittings shall be embedded in the trench with the invert conforming to the required elevations, slopes and alignment, and with the pipe bottom uniformly and continuously supported by a firm bedding and foundation.

- (c) For shorter than standard pipe lengths, field cuts may be made with either hand or mechanical saws or plastic pipe cutters. Ends shall be cut square and perpendicular to the pipe axis. Spigots shall have burrs removed and ends smoothly beveled by a mechanical beveler or by hand with a rasp or file. Field spigots shall be stop-marked with felt tip marker or wax crayon for the proper length of assembly insertion. The angle and depth of field bevels and lengths to stop-marks shall be comparable to factory pipe spigots.
- (d) Assemble all joints in accordance with recommendations of the manufacturer. Proper joints may be verified by rotation of the spigot by hand or with a strap wrench. If unusual joining resistance is encountered or if the insertion mark does not reach the flush position, disassemble the joint, inspect for damage, reclean the joint components and repeat the assembly steps. Fitting bells may permit less insertion depth than pipe bells.

9. Backfilling.

- (a) Materials for backfill shall be as specified on Monroe Township Municipal Utility Authority "Construction Details for Sewerage Systems".
- (b) Backfilling for PVC pipe shall be in accordance with ASTM D2321 and for all other pipe materials, in accordance with A.S.C.E. Manual of Practice 37.
- (c) Backfilling shall not proceed until the sewer, utility, or structure therein has been approved by the M.T.M.U.A. and unsuitable material removed from the site. Fill shall be placed in a manner to prevent nesting of rock fragments or in a manner such that voids are not created. Choked stone shall be compacted by hand tools as per details in Section S:5-17. Clean stone shall be placed from the crown of the sewer to a level one foot above existing or restored facilities. All other fill shall be placed in uniform layers not exceeding the thickness shown on the drawings or allowed by the M.T.M.U.A. Each layer of unclassified fill shall be compacted to the required density of the approved drawings with a vibratory compactor or other approved equipment.
- (d) The applicant shall submit for approval, prior to trenching operations, his/her method of compaction. Approval of any

proposed method shall not constitute a waiver of density requirements.

- (e) Where the excavation is made through or below permanent pavement, curbs, driveways, or sidewalks, or where such structures are undercut by the excavation, the entire backfill to the subgrade of the structures shall be made with bankrun gravel compacted to a density as shown on the approved drawings, as determined by A.S.T.M. D-1557 (MCD Proctor) for compaction and density of soils.
- (f) Backfilling shall not be done in freezing weather except by permission of the Engineer and it shall not be made with frozen material. No fill shall be made where the material already in the trench is frozen.
- (g) Gravel used for backfill shall consist of natural bankrun gravel having durable particles graded from fine to coarse in a reasonably uniform combination with no boulders or stones larger than 2 inches in size. It shall be free from slag, cinders, ashes, refuse, or other deleterious or objectionable materials. It shall not contain excessive amounts of loam and clay and shall not be lumpy or frozen. No more than 15 percent shall pass a No. 200 sieve.
- (h) A minimum depth of 36 inches of backfill shall cover the top of pipe before the trench may be wheel loaded.
- (i) A minimum depth of 24 inches of backfill shall cover the top of pipe before mechanical compactions may be used.
- (j) The applicant shall restore all removed or damaged paving, curbing, sidewalks, gutters, shrubbery, fences, sod or other disturbed surfaces to conditions equal to that before work began. The Engineer shall be the determiner of whether the conditions are equal.

S:5-13 Manholes

- a. Design and Construction Standards.
 - 1. Manholes shall be provided at ends of sewer lines, at intersections and at changes of grade of alignment. Distances between manholes shall not exceed 400 feet for sewers 18 inches or less in diameter, 500 feet for sewers greater than 18 inches in

diameter. Where lateral sewers enter manholes at elevations two feet or more above the invert, drop manholes shall be provided and drop pipes shall be built. Manholes shall be of precast concrete or cast-in-place concrete construction. Use of concrete block manholes is recommended only for special construction conditions which prevent use of precast manholes.

2. Precast manhole bases, without precast channels, barrels and cones shall be equal to reinforced concrete pipe and fittings conforming to A.S.T.M. Specification C-478, with round rubber gasketed joints, conforming to A.S.T.M. Specification C-361 and ASTM C-443. Maximum absorption shall be 9% in accordance with A.S.T.M. Specification C-478 Method A.
 3. Where manholes are over 16' deep a concrete safety platform shall be installed and the manhole base enlarged from 4 foot diameter to 5 foot diameter.
 4. Manhole frames and covers shall be of cast iron conforming to Specifications A.S.T.M. A-48, Class 30 and be suitable for H-20 loading capacity. Frames shall weigh a minimum 312 pounds, covers shall weigh a minimum 182 pounds. The letters "SANITARY SEWER" shall be cast integrally in the cover.
 5. All manhole covers in easements or in remote areas shall be provided with locking devices, unless otherwise required by the Authority. Manhole covers in low lying or flood prone areas shall be water tight and locking. Manholes shall be supplied with suitable adaptors for the various pipe materials used.
 6. Where manholes are located in all paved areas, the frames and covers shall be initially installed to stabilized base grade. Raise frame a cover with manhole bricks when adding final pavement to finished grade. (Revised 3-1-02)
 7. Details of manholes, manhole pipe connections, manhole frames and covers and resilient joint (ASTM C-923) with integrally cast in waterstop, are required to be as shown on the construction details drawing attached.
 8. Manhole ladder rungs shall be constructed with an integrally cast-in retainer clip; manhole sections with holes precast or drilled all of the way through the wall will not be accepted.
- b. Manhole Connections.
1. Pipe to manhole connections shall be of the flexible mechanical type with water stop embedded into manhole wall consisting of a

protruding flexible sleeve to be tightened by means of a stainless steel tightening ring with the annular space between pipe, sleeve, and manhole to be caulked with a flexible material, or a compression assembly with waterstop placed internally in the concrete manhole wall providing a positive watertight connection, 10 degrees of omnidirectional deflection to eliminate infiltration and shear due to settlement or ground movement.

2. Final grouting of all connections shall consist of non-shrink grout or a polyurethane foam ring impregnated with Portland Cement.
3. Openings for pipe shall be cast in manhole sections at elevations and directions shown on the approved drawings. Through lift holes will not be permitted for handling. Provisions for sections shall be numbered to match the manhole numbers shown on the drawings. Drop connection openings shall be located to provide pipe connections at the locations and elevations indicated on the drawings. Exteriors of all manhole sections shall receive two shop coats of epoxy waterproofing material. All manhole joints, including platform slabs, are to be reinforced. (Revised 1-16-03)

c. Assembly and Construction.

1. The base section shall be placed upon a bed of clean stone or concrete over undisturbed subgrade as shown on the drawings or as approved by the Engineer. Where trench for manholes is "over" excavated, the bed of clean stone shall extend to the limits of excavation. Stone bedding may be wrapped in filter fabric in order to prevent settlement. Manholes shall be oriented to pipe connection locations and set at locations and elevations shown on the drawings. Manholes shall be assembled using bases, risers and eccentric conical top sections or slab tops as shown or required. Eccentric reducing section shall be used to connect riser sections of different diameters. Joints between assembled sections shall be grouted on the outside and inside of walls with non-shrink grout. After grouting, all joints shall be protected on the outside with an approved bitumastic strip, eight inches, minimum, in width. The strip is a waterproofing product consisting of a sandwich of polyethylene on one side, release paper on the other side, and a mixture of rubber, asphalt and oils in the middle. Strips shall be applied in accordance with the manufacturer's instructions. Pipe connections shall be mortared on both sides of the manhole wall with non-shrink grout except where recommended otherwise and fully warranted by the manhole manufacturer. Waterways (channels) shall be constructed after the manhole has been installed. Shapes and sizes of waterways shall conform to the shapes of connection pipes with smooth

transition between pipes of different sizes. Change in direction of flow shall be made with a smooth curve with as large a radius as the size of the manhole will permit. Channels shall have a steel trowel finish or be of preformed PVC or fiberglass as approved by the Staff Engineer with 3000 PSI concrete poured around them to the sloping bench grade. Benches shall have a broom finish with striations at right angles to the slope.

2. Base sections, riser sections, conical sections, and grade rings shall be given a protective exterior coat consisting of two shop coats of asphaltic paint. The total dry film thickness shall be not less than 4 mils.
 3. Height adjustment between manhole concrete and cast iron manhole frame shall be constructed of the necessary combination of grade rings and unit masonry as shown on the drawings. Masonry units shall conform to ASTM C 32 grade MS or ASTM C139. Grade rings and masonry shall be set with a mortar mix using 1:2 ratio of cement to sand with equal quantities of masonry cement and portland cement. Masonry shall be laid in running bond on a full bed of mortar and full head joints. The inside and outside faces of the masonry shall be rubbed with burlap and coated with a wash coat of neat cement applied with a stiff bristle brush. The outside face of the masonry shall be finished with a minimum of two coats of bitumastic to a minimum total thickness of 24 mils.
- d. Shop Drawing and Certifications.
1. Shop drawings shall be submitted for approval showing all manufacturing details including reinforcement, inserts, joints, appurtenances, pipe connections and elevations and deflection angles of openings. Certificates of compliance shall be furnished attesting to conformance with ASTM C478 for the manhole sections, ASTM C443 or ASSHTO M-198 or Fed Spec SS-S-210 for the gaskets, and ASTM C361 and ASTM C443 for the joints. Terms of warranty of seals at pipe-to-manhole connections shall be subject to approval of the M.T.M.U.A..
- e. Field Inspection.
1. Any failure listed in Section 15 of ASTM C478 and any subsequent damage may be cause for rejection.
 2. The applicant must notify the Monroe Township Municipal Utilities Authority 48 hours in advance to schedule the necessary field inspections.

S:5-14 Clean Outs.

All clean outs shall be left a minimum of 24" above finished grade during initial construction. Immediately after final testing of all clean outs, installation of the cleanout protection box as shown on the construction details will be required and installed to final grade.

S:5-15 Wyes and Tees.

a. Location.

Location and orientation shall be as shown on the drawings or directed by the Township. Tees will be used only where deep house connection risers are to be installed or where specifically directed.

b. Materials and Installation.

Sizes of wyes and tees shall match those of the sewer lines and laterals or risers to which they connect. Adapters shall be furnished as required. They shall be plastic or ductile iron and of the same material as the sewer to which they connect. They shall be capped or plugged pending connection of laterals or risers. Caps or plugs shall be air tight and readily removable without damage to the wye or tee. Caps or plugs shall be marked by two 2" x 3" stakes. One stake shall be placed at the face of the cap or plug and shall extend upward from the invert to a minimum of eight inches above final grade. The second shall be placed a minimum of ten feet from the first stake and off the edge of existing pavement in a location to indicate the direction of the stem of the wye (or tee) and shall extend from four feet below to eight inches above final grade. In areas subject to traffic, upper ends of stakes shall terminate one foot below final grade.

S:5-16 Laterals.

a. The developer shall maintain and submit to the M.T.M.U.A. a map, tabulation, or other document, suitable in format, indicating for every lateral constructed, the following minimum information:

1. Station distance along the main sewer line from the lateral connection to the nearest downstream manhole.
2. Type, size and material connection: wye, tee, deep house connection, riser or other and CI, DI, PVC, ABS, etc.

3. Locations of bends in laterals if any.
4. Direction and length of lateral and depth of invert at clean out or end.
5. Deep house connection, station, and elevation.
6. Sewer laterals are an integral part of the sewer system and will be installed with same bedding and compaction requirements as sewer main.*

*Note: The Authority will not be responsible for any damage or cleanup caused by a backup of sewage without a check valve properly installed and maintained on the house lateral in accordance with the plumbing code. (Revised 2-19-02)

S:5-17 Cut Sheets.

- a. The developer shall 48 hours in advance of construction supply to the M.T.M.U.A. cut sheets for their approval. The cut sheets must be developed from field stake out and contain the following minimum information:
 1. Sewer.
 - (a) Stake out and layout of sewer lines according to plans and specifications.
 - (b) Stationing must match plans.
 - (c) Minimum 50' stationing with stake elevations.
 - (d) Cut to invert.
 - (e) Manhole, tee wye, and cleanout stationing.
 - (f) Proposed elevations and pipe grades.
 - (g) Alignment and offset stakes are required.
 - (h) Stationing of any special constructions, i.e., encasements, casings, crossings, etc.
 - (i) Proposed invert of deep house connection at main (if applicable).
 - (j) Forcemain: see water cut sheet requirement.

S:5-18 Construction in Acid Soil Areas.

- a. In the event that during excavation for sewer and water facilities construction through buried marshes, bogs, or where landfilling has taken place, the dewatering effluent contains excessive amounts of hydrogen sulfide, it is the contractor's responsibility to lower the hydrogen sulfide concentration to allowable levels before discharging the effluent to nearby surface waters. The allowable concentrations of hydrogen sulfide in dewatering effluent, as stated by the U.S.E.P.A. shall be 0.01 mg/l (10 PPB). Any concentration greater than This is to be considered excessive. A standard for the surrounding air has also been set, and it is also the applicant's contractors responsibility to ensure that the concentration of hydrogen sulfide (associated with construction) in the air, at any point, shall not exceed 45 PPB.
 1. Polyethylene Tubing and Tape Wrap (on all pipe materials except PVC)
 - (a) In all cases where acid soils are encountered and reported by the soils specialist, a polyethylene tubing and tape wrap shall be placed round the pipe effectively bagging each length of pipe protecting it from the acid soils.
 - (b) Polyethylene tubing and tape wrap shall be installed in accordance with manufacturers specifications and AWWA C105.
 - (c) The above bagging technique shall be used in addition to select backfill 2 feet above pipe embedment zone.
 - (d) Remaining trench shall be backfilled as specified under "Backfilling".
 2. Acid Soil Conditions.
 - (a) Due to the possibility of encountering extremely acid soil conditions in the course of construction, special acid soil requirements and conditions will apply.
 - (1) The top two feet of soil shall be stripped and stockpiled separately from the material to be excavated. A soils specialist, to be provided by the developer at his/her cost, will monitor the excavation operation.

- (2) When acid soils are encountered, as determined by the soil specialist, excavated trench material shall be returned to the trench in order of removal, i.e., lower material first followed by upper material. In addition, the top one to two inches of soil on which the deeper soil was stockpiled shall be scraped and placed below a depth of two feet. The quantity of material to be displaced by bedding and pipe as well as soil scraped from the stockpile area shall be subtracted from the deeper excavated material and this quantity of deeper material removed to a disposal site approved by the N.J.D.E.P.. Any soil disposed of in this way shall be covered with a minimum of two feet of cover to prevent rapid oxidation and subsequent acid formation. After backfilling the deeper soil, one ton of limestone per 2,000 square feet shall be spread over the deeper soil in the trench as a precautionary measure. This liming requirement shall be applicable in areas of well drained, non-saturated soils as determined by the soils specialist. The top two feet of soil, stockpiled for this purpose, shall then be replaced.
- (3) The excavated acid soil material shall not be exposed for a period longer than 8 hours. As a result of this condition, when acid soils are encountered, the trench opened in any construction day must be backfilled and the area cleaned up by the close of the day.
- (4) Temporary restoration of vegetated areas shall consist of mulching and shall be implemented at the end of each day's construction. Permanent restoration of the area shall begin as soon as the area is no longer needed for access and after the results of the incubation tests, where necessary, are available.
- (5) Where acid soils are encountered, a layer of topsoil of at least 6 inches shall be required, during restoration.
- (6) The soil specialist will perform pH tests on the soil to determine the lime requirements. If the pH is below 4, this is an indication that extremely acid soils have been mixed into the soil, necessitating an intensive liming effort in order to make the soil

suitable for plant survival. The soil specialist will be required to determine the lime requirement. This will necessitate an incubation test as follows:

- (i) The incubation test requires that a sample be oxidized for six weeks. The sample test must be air dried and ground so that the whole sample passes a 1/2 mm sieve. The lime requirement to reach pH 6.5 must be determined initially and again at 2 week intervals for six weeks using standard soil testing techniques. The lime requirement can be extrapolated to the area under consideration.
 - (ii) A minimum of 30 tons of limestone per acre on the incubation test result must be applied prior to seeding and planting where the pH is less than 4. Where the pH is 4 or greater, liming and fertilizing requirements set out in "Fertilizing and Seeding" shall apply.
- (7) All efforts must be employed to avoid spreading and mixing of the subsoil and any topsoil contaminated with extremely acid soil around the site and beyond the site. To This end, areas used for stockpiling shall be minimized. Equipment used for excavation and backfilling shall be cleaned, to the extent practical, at the end of each day's operation and the soil removed must be placed in the trench below a depth of two feet. No construction shall take place during significant rain storms and while the area is saturated to avoid smearing or spreading of the extremely acid soil material over the area.

3. Acid Soils Area.

Where subsurface investigations required for Tentative Approval indicate acid soils may exist in construction areas, additional testing shall be performed to determine definitively to what extent the condition exists. Initial tests and all subsequent testing, excavation, lime application, restoration, disposal, etc. shall be in accordance with N.J.D.E.P. specifications for construction in acid soils areas.

S:5-19 Elimination of Unsuitable Backfill.

a. Suitability of Backfill.

1. If, in the opinion of the Engineer, the material at or below grade to which excavation would normally be carried is unsuitable for foundation, it shall be removed in such widths and depths as the Engineer may direct according to the item entitled, "Other Earth Excavation", and be replaced with sand, gravel, or crushed stone, all as specified under "Sand Choked Crushed Stone Backfill Below Subgrade", or 3/8" clean crushed stone.
2. If, in the opinion of the Engineer, the material from any other part of the sewer trench is unsuitable for backfill, it shall be replaced with suitable surplus material excavated from other parts of the contract.

b. Furnishing of Suitable Materials.

If suitable surplus material is not available from other parts of the contract, then the applicant's contractor shall furnish suitable material when and where determined necessary by the Engineer.

c. Recommendation From Licensed Engineer.

The applicant may, as an alternate, provide a written recommendation from a licensed professional engineer as to suitability of on-site backfill material, its emplacement and compaction or suitable off-site backfill and its method of installation.

d. Disposal of Unsuitable Material.

1. The applicant's contractor shall note that all unsuitable backfill materials shall be separated from suitable material prior to disposal.
2. Except as otherwise approved, the applicant's contractor shall dispose of unsuitable surplus excavated materials promptly, at locations selected by him and in conformance with all state and local regulations. The applicant's contractor's attention is directed to acid soil mitigation procedures under "Acid Soil Conditions".

e. Disposal of Suitable Material

1. It is expressly understood that no excavated materials shall be removed from the site of work or disposed of by the applicant's contractor except as directed or approved by the Engineer.

2. All suitable surplus material is to be stockpiled in areas separate from the unsuitable material, where required. Suitable surplus excavated material shall be used for fill or backfill on other parts of the work to replace unsuitable materials and for embankment, where required. Surplus material used under pipe for replacement of unsuitable material below subgrade shall conform with "Sand, Gravel or Crushed Stone Backfill Below Subgrade".
3. Suitable surplus material not used as backfill or embankment shall be neatly deposited so as to flatten side slopes, fill depressions or for other uses within the limits of the project area, but not within floodplains, or as to alter pre-existing drainage patterns.

S:5-20 Sand, Choked Stone, Crushed Stone, Backfill Below Subgrade - Concrete Cradle-Sand Backfill Above Pipe Bedding and Pipe

- a. Gravity Sewers or Force Mains.

When determined necessary by the Engineer, the applicant's contractor shall furnish and place sand-choked stone or crushed stone wrapped in filter fabric as specified beneath gravity sewers or force mains to replace material removed from below subgrade. Material shall be placed where existing pipe crosses trench of new sewers and support is required, or where special fill is required as determined by the Engineer.

- b. Sewer Pipes.

When determined necessary by the Engineer, the applicant's contractor shall furnish and place concrete cradle under the sewer pipe. Concrete cradle shall be of Class "B" concrete.

- c. Pipe Bedding and Pipes.

When determined necessary by the Engineer, the applicant's contractor shall furnish sand backfill to be used to replace unsuitable material above the pipe bedding and the pipe, where no suitable material is available from any location within the contract area.

- d. Impermeable Backfill.

When determined necessary by the Engineer, the applicant's contractor shall furnish impermeable backfill.

- e. Sand and Crushed Stone.

Sand shall be bank run or mason sand comparatively free of clay and other deleterious materials.

Three-quarter inch crushed stone shall be either trap rock or limestone passing 1 inch mesh screen and retained by 1/4 inch mesh screen. The mixture producing choked stone shall be 50% sand and 50% 3/4" crushed stone.

f. Placing and Compacting.

The choked stone shall be spread in layers not over 6 inches thick and thoroughly compacted as specified.

The 3/8" clean crushed stone shall be placed as follows:

1. Excavating of trench established and stabilized (Shoring, dewatering, etc.)
2. Clean crushed 3/8" stone placed for a minimum of 6" thick.
3. Sewer line/water line placed on line and grade and remaining excavation filled with clean crushed stone to 12" above top of pipe. The remaining trench may then be backfilled as specified.

S:5-21 Final Cleanup.

- a. On or before the completion of the work, the applicant shall, unless otherwise especially directed or permitted in writing, tear down and remove all temporary building and structures built by him; shall remove all temporary works, tools, and machinery or other construction equipment furnished by him; shall remove, acceptably disinfect and cover all organic matter and material containing organic matter in, under, and around privies, houses, and other buildings used by him; shall remove all rubbish from any grounds which he has occupied; and shall leave the roads and all parts of the premises and adjacent property affected by his/her operations, in a neat and satisfactory condition.
- b. The applicant shall restore or replace, when and as directed, any public or private property damaged by his/her work, equipment, or employees, to a condition at least equal to that existing immediately prior to the beginning of operation. To this end the applicant shall do as required all necessary highway and driveway, walk and landscaping work. Suitable materials, equipment and methods shall be used for such restoration.

S:5-22 Deep Sewers.

- a. Where sewers are to be installed with more than sixteen (16) feet of cover the following requirements shall be met.

1. Ductile Iron Pipe.

Sewer main pipe shall be centrifugally cast ductile iron pipe of class shown on the drawings or at least Class 56 with push-on or mechanical joints and conforming to ANSI/AWWA C151/A21.51, ANSI/AWWA C111/A21.11, and ASTM A746. Marston calculations for the proper class of pipe shall be submitted as part of the Engineer's Report. Ductile iron pipe shall be bituminous coated and flexible type lining as described in ASTM A746.

(a) Ductile Iron Fittings. (tees)

Sewer pipe fittings shall be ductile iron with mechanical joints conforming to ANSI/AWWA C110/A21.10, ANSI/AWWA C111/A21.11.

(b) Lining.

The lining material for pipe and fittings shall be virgin polyethylene complying with ANSI/AWWA D1248, compounded with an inert filler and with sufficient carbon black to resist ultraviolet rays during aboveground storage of the pipe and fittings. The polyethylene shall be bonded to the interior of the pipe or fitting by heat.

(c) Surface Preparation.

All surface areas to be lined shall be blast cleaned comparable to the requirements of SSPC-SP6 or NACE #3.

(d) Application.

Polyethylene linings shall cover the inner surface of pipe and fittings. In pipe utilizing push-on gaskets, the lining shall extend from the spigot end through the socket to the edge of the gasket sealing area. In mechanical joint pipe the lining shall extend from the spigot end through the socket to the edge of the gauging ring. The lining in fittings shall cover the interior surfaces including the socket areas as defined above.

(e) Lining Thickness.

Lining in pipe and in fittings shall be 40 mils nominal thickness. Minimum lining thickness shall be 30 mils.

(f) Polyethylene Encasement.

In areas of highly acid soils D.I.P. sewers shall be encased with polyethylene wrap in tube or sheet form of 8 mils minimum thickness in accordance with ANSI/ASTM D1248 and ANSI/AWWA C105/A21.5.

(g) Method of Construction.

- (1) Methods of construction and testing shall conform to paragraphs b. and c. hereinbefore described to the extent applicable. All pipe and fittings and appurtenances shall be handled, assembled, set to grade, jointed, and bedded in accordance with good practice, manufacturers guides and ANSI/AWWA standards.
- (2) At all areas where ductile iron pipe is exposed to corrosive soil conditions, runs parallel to cathodically protected gas lines on the same side of the road or crosses gas lines, the ductile iron pipe shall be protected by encasing the pipe with plastic. Polyethylene film shall be applied loosely but continuously to the pipe with joints in plastic made by polyethylene adhesive tape. Care shall be taken in the installation and backfilling operation to prevent tearing the plastic and exposing the bare metal pipe.
- (3) In any areas where excavation for trenching and pipe installation causes water pipe or service connections or other structures to be undercut and installed on backfill, the backfill shall be constructed with the full depth of approved granular material compacted to a density of 90 percent, except for the pipe zone and pavement zones which will be 95%, as determined by the A.A.S.H.O. Method T99. Water pipe, services or structures may then be installed in trenches properly excavated in the properly backfilled areas. Soil tests may be required by M.T.M.U.A. to verify quality of backfill.

S:5-23 Existing Paved Surfaces.

- a. Existing paved roads or streets shall be repaired to the satisfaction of the applicable agency (i.e. Township Engineer, County Road Supervisor or N.J.D.O.T.)

1. Cutting and Removing Pavement.

- (a) The line between the trench and the existing pavement to remain shall be cut with a saw, or approved equal, so as to leave a smooth, straight, and vertical edge. The existing pavement may be bituminous, brick, block, non-reinforced concrete, reinforced concrete, etc. The excavated pavement shall be broken up and removed.
- (b) Where excavations are to be made on concrete roads, the existing concrete shall first be saw cut and removed. All protruding reinforcing rods shall be cut off and removed. Any loose or broken longitudinal portions of adjacent existing lanes shall be removed and replaced.

2. Temporary Pavement Repairs.

- (a) During the interval between the completion of backfill and the time of placement of permanent paving, all pavement and drives shall be maintained in a safe and satisfactory condition. The applicant's contractor shall install all temporary pavement repair in accordance with these specifications.
- (b) Temporary pavement repair shall be installed by the end of each day, unless otherwise approved by the Engineer.
- (c) Temporary pavement repair shall consist of 4 inch minimum (compacted measure) of cold patch on all Borough roads and 6 inch (compacted measure) of cold patch on County and State roads. Prior to placing of cold patch, the trench shall be thoroughly cleaned of all loose and foreign material. It shall not be applied when surface is wet or dusty. Application shall be made only when the condition of the surface is acceptable to the Engineer.
- (d) The contractor shall continuously maintain temporary paving for the entire period it remains in place; shall inspect trenches at such intervals as may be necessary, including but not limited to immediately following rainstorms, winter thaws, and similar occurrences which may cause settlement, erosion, or other problems; and shall promptly make necessary repairs to maintain trenches in a satisfactory condition. In the event the applicant's contractor fails to make such repairs, the applicant may make such repairs as are deemed necessary and the contractor shall pay for the cost of this work.

- (e) The applicant's contractor is required to repair all areas that are damaged by his actions during construction. If the damaged areas are outside the maximum trench width shown on the detail, additional costs of restoring the damaged areas shall be borne by the contractor.
- (f) The Engineer, giving one week's notice, may direct the applicant's contractor to remove the cold patch surface and replace it with the permanent base course (bituminous stabilized base).
- (g) If, at the time of the placement of temporary pavement, it is demonstrated that the applicant's compaction method has achieved the specified soil densities within the 24 hour time limit for the placement of temporary pavement, the Engineer will approve the placement of the permanent base course in lieu of cold patch. If the specified soil densities are not achieved within this time limit, the applicant's contractor will be required to place cold patch as specified. The placement of cold patch should not be construed as relieving the applicant's contractor from any of the requirements of the backfilling specifications.

3. Pavement Repairs in County Roads.

- (a) The County road, when opened, shall be cut in straight lines; the pavement and the base shall be removed prior to repairing to at least twelve (12) inches beyond the outer limits of the sub-grade that is to be disturbed, leaving a twelve-inch shoulder of undisturbed material in each side of the excavated trench. The face of the remaining pavement shall be approximately vertical. A power-driven concrete saw shall be used so as to permit complete breakage of concrete pavement or base without ragged edges. Asphalt paving shall be scored or otherwise cut in a straight line.
- (b) Trench restoration shall be in accordance with the then Middlesex County Road Department specifications.

4. Trench restoration within county roads right of way but outside of paving area.

- (a) The trench shall be open cut in a straight line; down to 6" below the invert of the pipe with trench walls almost vertical.

- (b) Immediately after the work is performed for which the opening was made, backfilling with 3/8" clean crushed stone to 6" below invert and up to the springline of pipe shall be completed and compacted by hand chocking method. Backfilling the remainder of the trench shall be free of excavated material from trench, clay, or black loam and be of dense graded aggregate compacted in maximum 8" thick layers with no exceptions unless authorized by the Middlesex County Roads Engineer. The backfill shall be compacted by mechanical means to a degree equivalent to that of the undisturbed ground in which the trench was dug to within four (4) inches of the surface. The remaining 4" of open trench shall be filled in with 4" thick topsoil, fertilized, seeded, type P, and straw mulched on top.

S:5-24 Existing Sewer Replacement.

- a. Where existing active sewers are to be replaced, the work shall be done with materials and methods described elsewhere as far as possible. Other special conditions and requirements shall be as described hereafter or as required and approved by M.T.M.U.A. or other authorities.
- b. The applicant's contractor shall confer with M.T.M.U.A., local police, fire protection, school, street department, and other affected parties to properly coordinate the work and provide for their needs. At least 48 hours notice shall be provided to all parties of the time work will be done. Road closings and detours must be approved in advance by the Township Council.
- c. The work shall be organized and performed so that discrete segments will be completed, tested and returned to service on a daily basis. Note that accurate elevations and grade of all pipes and inverts is critical to successful performance and completion. The applicant's contractor will be required to correct any deficiencies.
- d. Sanitation.
 - 1. All sewage flow coming to the sewer being replaced shall be diverted upstream and pumped around the work area and discharged properly into the sewer downstream of the work area. No sewage shall be allowed to flow open over the ground or street surface or in the gutters, nor to drop open in manholes.
 - 2. All house connections shall be maintained in operation and sewage intercepted or arrangements made with homeowners for use restrictions as approved by M.T.M.U.A.. Any soil or other

areas that may be contaminated shall be disinfected and treated with chlorine, lime or other methods approved by M.T.M.U.A..

e. Manholes.

1. Existing manhole openings shall be modified and used. Any enlargement or reorientation of existing openings shall be neatly cut as needed. Existing manholes shall be machine-cored and pipes sealed in the opening by use of a "Link-seal" as manufactured by Thunderline, Inc.
2. Inverts shall be cleaned, surface roughed to hold finish mortar. Invert shelf shall be raised to 80% of trunk pipe diameter (11-1/4 inch) and finished as described in Section S:5-13.
3. Channels shall be reshaped and graded as necessary with steel trowel finish as described in Section S:5-13. Sewage shall not be allowed to flow against unprotected new mortar for at least three (3) days or as approved by M.T.M.U.A.
4. Where trench excavation will remove backfill on one side of a manhole to a depth of more than eight (8) feet, the far side of the manhole shall also be excavated to prevent the depth of unbalanced earth from exceeding seven (7) feet. Proper ventilation, illumination and assistance will be provided all workmen in manholes.
5. Where manholes are over 16' deep, safety platforms shall be placed at each 16 foot level.
6. Manholes that are less than 16' are required to have a base section and reducing cone. Slab top manholes within pavement may be permitted at the discretion of the Authority's Engineer.

S:5-25 Pumping Stations.

- a. All raw sewage shall be screened and hydraulically ground up before pumping. Sewage screens and hydraulic grinders shall be installed in a separate concrete manhole or vault. The concrete structure shall be provided with a bypass channel, adequate forced ventilation (12 air changes per hour), lighting, aluminum ladder, Bilko door (with 2 ladder-up bars by Bilko or approved equal), bar screens, stop gates with poly glides and fiberglass grating 300 psf rated (N.S. type) cast into channel walls. Sufficient space shall be provided for the removal of the hydraulically operated grinder and operation of the stop gates, raking of the bar screens and bypass channel. The concrete manhole or vault shall be

exterior waterproof epoxy coated (2 coats) including top and interior PVC lined (Dura Plate 100) or equal. (Revised 1-16-03)

- b. An air release/vacuum assembly will be required in a separate concrete manhole just outside the valve pit discharge side on the force main to release small amounts of accumulated air during pump starts and open impending vacuum to admit air when pump starts. Air/vacuum assemblies shall be by A.R.I. or approved equal. The manhole shall be exterior waterproof epoxy coated (2 coats) and interior epoxy coated white (2 coats). The concrete manhole shall be provided with "A" lok joint old style or approved equal with aluminum ladder, Bilko door and two ladder-up safety bars by Bilko or approved equal. The concrete manhole shall contain a trapped ball style floor drain and poured in place floor, sloped to drain. Floor drain shall be by Zurn model 742 or approved equal piped to wet well. Piping and appurtenances shall be supported by a hot dipped galvanized adjustable floor support, a minimum of 18" off the floor and all fittings shall be full body with plug valves manufactured by DeZurik or equal. All fasteners shall be stainless steel. (Revised 1-16-03; 7-17-03)

- c. At least two (2) submersible pumps with control panel by Flygt Pump, KSB, or approved equal shall be provided, each capable of handling the total peak flow. All pumps shall be supplied with certified pump curves. If more than two pumps are used, their capacities shall be such that upon the failure of the largest pump, the others will handle the peak flows. All pumps and equipment shall be 460 volt 3 phase explosion-proof and damp-proof. A separate concrete vault shall be provided on the discharge piping side of the wet well to contain piping, valves and fittings. All fittings to be full body type; valves to be plug type with wheeled geared operators by DeZurick or equal, check valves shall be by Golden Anderson, air/oil cushioned swing type or approved equal. The valve pit shall be provided with adequate static ventilation (separate pipe type with 180° bend with bug screen installed opposite end from aluminum Bilko door). The concrete vault shall be provided with "A" lok joint old style for pipe penetrations or approved equal with aluminum ladder and 2 ladder-up safety bars by Bilko or approved equal. The aluminum ladder shall be centered under an aluminum Bilko door with stainless steel hardware including channel drain piped to outside of vault or approved equal. The concrete vault shall contain a trapped ball style floor drain and poured-in-place floor, sloped to drain and piped back to wet well. Floor drain shall be by Zurn – Model 742 or approved equal. Piping and appurtenances shall be supported by a hot dipped galvanized adjustable floor support, a minimum of 18" off the floor. All fasteners shall be stainless steel type. Valve chambers are to be interior epoxy coated white (2 coats) and waterproofed exterior epoxy coated (2 coats) including top. (Revised 1-16-03)

All sewage pump motors shall be capable of running off reduced voltage starters.

- d. Submersible pumps shall be installed in a wet well deep enough to maintain a flooded condition (positive suction head) at starting. The minimum internal dimensions of the concrete wet well shall be ten (10) feet diameter by ten (10) feet high and 10 inches thick. The wet well shall be completely separate and shall be provided with adequate ventilation, lighting, and drainage. Sufficient space shall be provided in the wet well for the removal of explosion-proof submersible pumps and motors. Where operational/maintenance duties are required in enclosed areas, forced ventilation shall be provided with a minimum capacity of 12 air changes per hour. The capacity of the wet well shall not exceed ten minutes when flow is at the average dry weather rate. The floors of the wet well shall slope at least 45 degrees toward the pump suction with one deep sump pit below wet well floor to the dimensions required by the M.T.M.U.A. The pump suction shall terminate with a flared straight end. Aluminum Bilko doors with stainless steel hardware, double leaf, piston assist or approved equal shall be supplied with locking device and tee handle. Doors shall be sized large enough to pass both pumps with 12" clearance to door using hoist. Wet wells shall be supplied with a fabricated aluminum ladder and Bilko ladder-up safety bars opposite pump door opening. Removable type ladder shall be located under its own Bilko door with a minimum opening of 24" x 24". Wet wells are to be waterproofed exterior epoxy coated (2 coats) and interior PVC lined (Dura Plate 100) or equal.

Note: All wet wells, grinder chambers and valve chamber shop drawing submissions shall include flotation calculations, signed and sealed by a N. J. P. E.

(Revised 1-16-03)

- e. The wet well shall be supplied with a multitrode level monitoring and control system. There shall be a separate bypass off the force main just outside of the wet well with Evertite disconnect coupling and (2) plug valves with gear operators to allow temporary bypass of the pump station should repairs be required in the future to the submersible pumps.
- f. An auxiliary source of power shall be provided for electrically driven explosion-proof 230/460 volt 3 phase submersible pumps and equipment required for operation. The auxiliary power shall be diesel or natural gas operated (if gas mains available to area) and shall be housed in an approved superstructure. An automatic transfer switch with timer shall be interconnected enabling the gen set to operate when live power is discontinued and to shut down the gen set when line power is returned. Timer required for automatic gen set exercising under load. All diesel

operated facilities shall be supplied with sufficient above ground fuel storage in concrete vault for a twenty-four hour operating period.

- g. Flow measurement equipment shall be by a magnetic flowmeter. Coil excitation whose current shall be pulsed bi-polar DC. The flowmeter shall be auto-zeroing. The flow tube shall be 304 stainless steel with carbon steel flanges and welded steel coil enclosure. The flow tube liner shall be polyurethane or hard rubber. The electrodes shall be 316 stainless steel. Grounding shall be by grounding electrodes (probes) of the same material as the sensing electrodes. Grounding rings and straps shall not be acceptable.
- h. General.
 - 1. The overall systems characteristics shall be as follows:
 - (a) Accuracy: 1.0% of rate from 1 to 33 ft/sec.
0.01 ft/sec below 1.0 ft/sec.

The accuracy of each meter shall be verified by calibration in a flow laboratory traceable to the National Institute of Standards (NIS).
 - (b) Full scale: Adjustable from 3.0 ft/sec up to 33 ft/sec.
 - (c) Outputs: Bi-directional: isolated 4-20 mAdc and 24 Vdc scaled pulse.
 - (d) Minimum conductivity: 1 microohm/centimeter
 - (e) Power consumption: 11 VA maximum
 - (f) Sensor and transmitter protective coatings shall be 7 mils of epoxy or approved equal.
 - (g) Temperature limits, ambient: -20 F to + 140 F.
 - (h) Temperature limits, process: Elastomers +160EF; Teflons +300EF.
 - (i) Field Selectable Low Flow cutoff: 0 - 9%
 - (j) All printed circuit boards shall be interchangeable as a single module. Sensor calibration shall remain unchanged.
 - (k) The manufacturer shall furnish application performance guarantee with submittals.

- (l) Environmental rating: NEMA-4X, Class I, Division 1, Groups B, C and D for both sensor, and electronics whether remote or sensor mounted.
- (m) Meters 4" and smaller shall be accidental submergence proof, 30 ft., 48 hours standard.
- (n) The LCD display and 4 - 20 mAdc outputs shall have field adjustable dampening.
- (o) The manufacturer shall have a minimum of 5 years experience in the manufacture of bi-polar DC magnetic flow meters.

i. Transmitter.

- 1. The transmitter shall be microprocessor based with integral 4-digit flow rate indicator with movable decimal point and 10-digit totalizer, all in engineering units. The transmitter shall be mounted on the flow sensor, wall or 2-inch pipe mounted as indicated in the instrument list.
 - (a) The preamplifier input impedance shall be a minimum of 10^{11} ohms. Electrode cleaners shall not be acceptable.
 - (b) Power Requirements: 117 Vac, "10% 50/60 Hz.
 - (c) Selection and change of all flowmeter settings shall be made by use of a magnetic probe (Magcommand) without opening the transmitter enclosure. The software shall incorporate an owner selectable password.
 - (d) Totalized flow and programmed configuration shall be maintained in memory for up to 10 years.
 - (e) Interconnecting cable to connect the sensor to the transmitter shall be furnished by the magnetic flow meter manufacturer.

j. Optional Features.

- 1. The following optional features are required when listed in the instrument schedule:
 - (a) Remote mounted electronics.
 - (b) 1/2% of rate calibration
 - (c) 300# flanges

- (d) Empty pipe detection (6" and larger)
- (e) Meters 6" and larger, accidental submergence proof, 30 ft., 48 hrs.

k. Magnetic Flowmeters.

1. The magnetic flowmeters shall be Sparling Tigermag Series 600, or approved equal.
2. All interior piping and exterior piping above ground (including piping in wet well) shall be prime coated and two finish coats with a paint approved by the Staff Engineer.
3. All sewage pump stations superstructure shall be large enough to house odor control facilities and related equipment supplied by developer. This superstructure shall be as described below.
4. All pump stations shall be located in areas that are not subject to flooding and that are accessible by motor vehicle. Each pumping station must be on a parcel of land adequate to meet the requirements of the Authority for operations and maintenance (minimum 100' x 100'). The plans and specifications must include provisions for lawns, shrubbery, eight (8") inch thick paved drive and four (4") inch thick concrete walk, and the entire property must be surrounded by a six foot chain link fence with three strands of barbed wire above the fence. Truck and pedestrian gates shall be provided.
5. Electrical motors and power equipment shall not be installed in subsurface chambers. The superstructure shall conform to the neighborhood architecture and shall be vandal proof. The superstructure must be of insulated wood and masonry construction. Insulation shall consist of 6" within walls with 12" in ceiling en faced with vapor barriers. Automatic alarms shall be installed independent of station power and they shall give warning of high and low water, power failure or breakdown. Also, a vandal alarm compatible with those in use by the Authority shall be provided. These alarms shall be connected to an annunciator on-site and remotely by telemetry to the Authority offices. The applicant shall provide and install at his/her expense a telemetry system identical to existing M.T.M.U.A. telemetry systems in operation at other sewer pumping stations consisting of the following components:
 - (a) Solid state electronic level transmitter as manufactured by RACO, Model Verbatim #VSS-8C with 4 channel analog.

- (b) Direct acting 12" circular level recorder using linear weekly charts.
- (c) Remote terminal unit (RTU), Model VSS-8C by RACO.
- (d) Voltage surge protection.
- (e) Alarm dry contacts required:
 - (1) Security
 - (2) General mechanical failure
 - (3) Pump #1 running
 - (4) Pump #2 running
 - (5) Generator failure
 - (6) Generator running
 - (7) Flow totalizer (pulse)
 - (8) Flow (4-20 ma)
 - (9) Low wet well
 - (10) High wet well

I. Facilities.

Adequate light, ventilation, dehumidification, heat and fresh water supply with hose outlets and floor drains by Zurn Model 742 or approved equal shall be provided for all stations. Floor drains to be piped back to wet well. Toilet facilities shall be provided for all stations with superstructure. No connections between freshwater and sewage pumps or pipes are permitted and proper backflow prevention is required.

(Revised 1-16-03)

m. Repair Tools.

Complete repair tools and accessories along with spare parts, shall be provided with the pump stations.

n. Force Mains.*

Force mains shall be ductile iron pipe, as specified herein and velocities shall be no less than two (2 fps) feet per second nor more than five (5 fps) feet per second at the design pumping rate. Force main diameter shall

be 4 inch minimum. Properly designed air release valves shall be provided on high points of the force main. Air and vacuum valve assemblies will be required at critical locations. The force main shall be provided with acceptable blow-off manholes. A pigging launch shall be provided. Where the force main ties into the gravity system, the manhole receiving the force main and the next three downstream manholes are to be waterproofed exterior epoxy coated (2 coats green) and interior PVC lined. All force mains shall be provided with pipe tracing wire as follows: Prior to backfilling the trench (whether DIP or PVC), a PVC coated single solid 8 gauge copper trace wire shall be installed in the pipe embedment zone directly over the force main. The copper trace wire shall be installed for the entire length of the force main with extension leads coming up through valve boxes at air release and remote blow off manifold assemblies or a separate utility box where force main begins at the valve pit terminals at the gravity sewer connection. A continuity test after backfill completed shall be performed by the contractor to insure that the copper wire or its connections have not been pulled apart. All connections shall be performed with CAD weld system approved by the M.T.M.U.A. Engineer. All buried full body mechanical joint fittings, whether installed on DIP or PVC force mains when determined to be installed in acid soils, shall have all bolts and nuts manufactured from stainless steel, if determined by the Staff Engineer. Minimally, where acid soils are not present, the exterior of the full body mechanical joint fitting and its standard bolts and nuts shall be bituminous coated (2 coats) and poly bagged.

*Note: Size of force main and its discharge affect how many downstream manholes will be PVC interior lined. A 1,000 ft. minimum downstream sewer and manholes are typically PVC lined.

(Revised 1-16-03; 7-17-03))

o. Space Requirements.

Space must be provided in the superstructure housing generator and/or motors and electrical equipment for odor control equipment and tanks. All piping must be provided. Odor control, tanks and equipment must be furnished. These facilities must be compatible with existing M.T.M.U.A. odor control chemical usage (i.e. Bioxide).

p. Detailed Estimates.

Detailed estimates of operational costs of the pumping station must be submitted with the Engineer's estimate. Alternate pumping stations where appropriate due to low flows will be considered by the Authority.

q. Incoming Electrical Service (Transient voltage surge suppression).

1. System voltage surge protection shall be by Liebert Interceptor series or approved equal whose size (model #) shall be determined by a professional electrical engineer based on number of life cycle surges per mode and phase with the following characteristics:
 - (a) Noise Attenuation: the filter shall provide insertion loss with a maximum of 60 C/B from 100 khz to 100 mhz per 50 phm insertion loss methodology from MIL 220A.
 - (b) Dual Form C Contacts: the specified system shall have two sets of electrically isolated form C dry contacts, one normally open, and one normally closed for remote monitoring.
 - (c) Overcurrent Protection: all components are individually fused and rated to allow maximum specified surge current capacity. For every 100 ka of surge current capacity, 120 amps RMS of internal fusing shall be provided.
 - (d) Life Cycle Testing: the system shall be duty life cycle tested to survive 10 ka, 20 kv, 1EEE C 62.41 category C3 surge current with less than 5% degradation of clamping voltage. The minimum number of surges the unit shall be able to protect against. (See table below:)

# of Life Cycle Surges per Mode		# of Life Cycle Surges per Phase	
L-N	L-G	N-G	(L-N+L-G)
3,000	3,000	3,000	6,000
6,000	6,000	6,000	12,000
9,000	9,000	9,000	18,000
12,000	12,000	12,000	24,000

- (e) Enclosure: The TVSS shall be provided in a heavy duty NEMA 12 dust – tight, drip – tight enclosure with no ventilation openings. The cover of the enclosure shall be hinged on the left side with a drawing pocket provided inside the door for storage of drawings and manuals. All monitoring indication will be visible without opening the

door. The enclosure dimensions vary according to specific model number (maximum dimensions shall be 30 X 24 X 9).

- (f) Modes Of Protection: All modes shall be provided, Line to Neutral, or Line to Line, Line to Ground, and Neutral to Ground (where applicable).
- (g) UL 1449 Ratings: The maximum UL 1449 listed surge ratings for each protection mode shall not exceed the following in any mode of protection:

System Voltage	Without Disconnect	With Disconnect
120/208 or 120/240	400 V	500 V
208, 240, 277, 230/400, or 277/480	800 V	1000 V *(800 V)
346, or 346/600	1200 V	1500 V
480	1500 V	1500 V
600	2000 V	2000 V

- (h) Agency Listing: All TVSS devices shall be UL 1449 listed and labeled, UL 1283 listed and labeled, and CSA listed. Control Concepts/Liebert is also company certified ISO 9001 for manufacturing, design, and service.
- (i) Warranty: A full five year, on site, parts and labor warranty.
- (j) Integral Fused Disconnect: The specified system shall include a 300 KAIC integral fused disconnect switch located in line with the system enclosure with an external manual operator. The switch rating is as follows:

Amp Rating
40 Amps
40 Amps

80 Amps
100 Amps

- (k) Audible Alarm: The specified system shall be equipped with an audible alarm that shall be activated when summary alarm contacts are activated. An On/Off switch shall be provided to silence the alarm and an alarm push-to-test switch shall be provided to test the alarm function. A visible LED will confirm whether alarm is on or disabled. Both switches and audible alarm will be located on the unit's front cover.
- (l) Single Transient Counter: The specified system shall be equipped with a single, adjustable transient counter. The single counter shall total transients that occur in the common mode. The counter will be located on the unit's front cover and features a seven digit LCD, a lithium battery (with 10 year life), and a reset switch.
- (m) Dual Transient Counters: The specified system shall be equipped with two, adjustable transient counters which total transient surges in both normal and common modes. The counter will be located on the unit's front cover and features a seven digit LCD, lithium batteries (with 10 year life), and remotely located reset switches.
- (n) Remote Monitor Panel: The specified system shall include a self contained, UL Listed, monitoring panel. Input power to the monitoring panel shall be equipped with a 6 foot power cord with a 3 NEMA 5-15 plug. The monitor shall have an audible alarm, red and green LED's, silence switch, and a test switch.
- (o) Reduced Voltage Starters: Shall be furnished including all labor, equipment, material and incidentals necessary to install completely and make ready for operation, two (2) reduced voltage solid state starters as required for the operation of (2) sewage pumps and motors. This shall include all logic, wiring and interfacing with other control components and systems.
- (p) Ground and Lightning Protection: Furnish and install grounding systems complete in accordance with the minimum requirements established by the NEC, NFPA, and as shown on the drawings. In addition to the NEC

requirements the following shall be permanently and effectively grounded:

- (q) Building electrical equipment:
 - (1) Equipment grounding shall be made between ground pads and system ground grid.
 - (2) The lightning protection system shall be installed on the highest portions of the structure and as shown on the drawings.
 - (3) The system shall consist of air terminals, roof conductors, down conductors and shall be in accordance with the National Fire Protection Association lightning code, ANSI C5.1 and shall bear the master label of UL.

S:6 INSPECTION OF SEWERAGE SYSTEM DURING THE COURSE OF CONSTRUCTION.

S:6-1 General.

a. Authority.

All inspection of construction of sewerage systems shall be under the jurisdiction of the Engineer for the Authority, either directly or through inspectors under his/her supervision. He shall enforce compliance with the approved plans, specifications, Authority Rules and Regulations and policies. He shall have the authority to stop work in the event of non-compliance.

b. Pre-construction Meeting Required.

Prior to construction of any sewer project the following is required:

1. A pre-construction meeting with the M.T.M.U.A. Staff Engineer, the developer, and the contractor must be scheduled well in advance of construction.
 - (a) Agenda items to be covered shall be permits, cut sheets, material, pipebedding, dewatering, installation, backfill, trench composition, paving, punch lists, as-builts, testing and any other conditions pertaining to the project.

c. Hours of Testing.

Construction or testing of sewerage systems shall be performed during the regular M.T.M.U.A. working hours of 8:00 A.M. to 4:30 P.M. Monday thru Friday unless otherwise approved by the Authority.

d. Notice to Authority.

The applicant shall give 48 hours notice to the Authority prior to construction or testing of sewers at all times during the construction period for the project. Should any sewer construction be performed when a qualified inspector is absent due to the applicant's failure to provide the proper notification, the Authority will require said work to be uncovered at the applicant's expense. Failure to do so will result in non-acceptance of the work.

e. House Connections.

1. The applicant shall also furnish the name of the occupant, the street address and lot and block number of every connection made to an approved section of sewer main during the month.
2. No house service connections shall be made to a street main, whether tested or not, unless under the inspection of the Engineer for the Authority.
3. When a section of sewer main has been satisfactorily tested, then all individual house connections must also be satisfactorily tested.

f. Temporary Plugs.

1. A temporary, leak-proof, masonry bulkhead type plug shall be installed in the downstream (outlet) side of the manhole furthest downstream in any sewer main or branch under construction and shall remain intact and unloosened until written permission is received from the Authority Engineer to remove same.
2. This permission will not be granted until each section of the sewer has been cleaned and flushed in a manner acceptable to the Authority's Engineer.

g. Visual Inspections, Television Inspections.

All sewer lines shall be inspected visually to verify accuracy of alignment and freedom from debris and obstruction. Should any deficiencies appear or a question arise by the M.T.M.U.A. Staff Engineer, then the entire line in question will be television inspected in accordance with the following sections on television inspection. The full diameter of the pipe for straight alignments shall be visible when viewed between consecutive manholes.

h. Power Flushing Required.

All sewer lines prior to inspection and testing shall be power flushed clean using a jet flushing truck. No other means will be accepted.

i. Certifications.

Upon satisfactory completion of construction, the Authority's Engineer will certify to the Authority and to the N.J.D.E.P. that the project has been inspected and tested under his/her supervision. The applicant's Engineer must certify to the Authority and to the State that the project has been constructed according to the approved plans and specifications. N.J.D.E.P. requires that such certification be given prior to its issuance of a permit to operate new sewage facilities.

j. Responsibilities of Applicant.

1. The applicant shall provide all labor, pipe, fittings, gaskets, manholes, accessories, and other materials, equipment, special services, and all else necessary to furnish, install, and provide complete, in place, all sewers and appurtenances as required by the plans and specifications or as required in order to fulfill the intent of same. All work and materials shall conform to the requirements of the M.T.M.U.A. Rules and Regulations, of Monroe Township in Middlesex County.
2. The applicant shall protect and take care of all work until final completion and acceptance thereof. During construction, the applicant shall keep the site free and clean from all rubbish and debris and in a sanitary condition, and shall promptly clean up the site after being notified by the Owner.
3. After completion of the work and before he makes application for acceptance of the work, the applicant shall clean the site of the work and all ground and property that has been occupied or used by him in connection with the work, removing all rubbish, surplus materials, false work, temporary structures, and equipment, and all parts of the work shall be left in a neat and presentable and operable condition.
4. All streets and roads used shall be kept free from dust and unless permission to close certain streets or roads is obtained, at least one-half of the width of each street or road shall be kept open to traffic. Construction safety warning signs, cones and lighted barricades shall also be used when any excavation occurs in existing roadways.

5. The applicant's contractor shall take care of storm water and waste water reaching the right-of-way from any source and shall prevent damage to property on or off the right-of-way due to interruption or diversion of such storm or waste water on account of his/her operations.

S:6-2 Testing of Completed Sewerage System.

- a. Required; Cleaning Prior to Testing.

All gravity sewer facilities shall be subjected to physical visual inspection, lamping, air pressure testing, television inspection (where directed by the Staff Engineer), and deflection testing. Prior to testing, all lines and manholes shall be cleaned by high pressure hydraulic cleaners (jet flushing trucks), string left for pulling mandrel, as-builts reviewed and approved by the M.T.M.U.A., permits to operate sanitary sewers, and all punch list items completed.

- b. Completion Required Prior to Testing.

Sanitary sewer system must be complete before testing by the Authority. This includes finished manholes inside and out, clean outs in proper location and base course pavement over lines to be tested, easements final graded, and punch lists completed. All manholes in pavement shall have their frames and covers set to stabilized base pavement grade. When finish pavement is applied, 2" riser rings (solid one piece cast iron) shall be used to raise the manhole frames and covers to grade. In no case shall manhole frames and covers be set to finish grade of finish pavement prior to application of finish pavement (by tamping of stabilized base around frames and covers).

- c. Cleaning (Jet Flushing Trucks).

1. The developer's contractor shall furnish high pressure hydraulic cleaners, vacuum trucks (where necessary) and all else necessary to clean sanitary sewers; sanitary sewers to be television inspected, lamped and mandril tested. He shall also supply adequate traffic control, power, and adequately trained technicians to perform the required work.

2. The preparatory cleaning should remove all construction mud, sand, or gravel from the sewer pipes to be inspected.

- d. High Pressure Hydraulic Cleaners.

1. High pressure hydraulic cleaners used to clean the sewer lines shall have a heavy duty positive displacement type water pump with a minimum continuous rating of 65 GPM at 1,250 psi. A minimum 600 LF of hose shall be mounted on a power driven hose reel with manual rewind. The hose shall be 1" ID hose having a 2,000 psi working pressure and a minimum burst pressure of 5,000 psi. The water tank shall have a minimum 1,250 gallon capacity. The Contractor shall supply all nozzles and accessories as needed to complete the cleaning operation.
2. The cleaner truck shall be equipped with amber strobe beacon lights for traffic protection.
3. The tests shall be performed between two manholes or as otherwise directed by the Engineer for the Authority and shall include all related sewerage including laterals and clean outs.
4. The applicant's contractor shall furnish all labor, material and equipment necessary for the testing.
5. Air pressure testing shall start at a minimum 5.0 PSIG with a 0.5 PSIG allowable drop over the time required (see Table II, paragraph e below).
6. The air pressure correction, which must be added to the 5.0 PSIG normal test starting pressure, shall be calculated by dividing the average vertical height, in feet of groundwater above the invert of the sewer pipe to be tested, by 2.31. The result gives the air pressure correction in pounds per square inch to be added. Groundwater height shall be determined by the developer using a method approved by the Authority. In no case should the starting test pressure exceed 9.0 PSIG.
7. When required by the M.T.M.U.A. Staff Engineer, the developer or his/her contractor shall perform television inspections of any and all sanitary sewers found deficient during the lamping, mandril or air testing phase of the project. This selective television inspection will be required between 2 manholes immediately after high pressure jetting or flushing out of the sewer line. In no case shall television inspection be performed unless the high pressure flushing has been accomplished to the satisfaction of the M.T.M.U.A. inspector.
8. Where required, the television inspection will be required for every lineal foot of sewer pipe installed within the development, or in some cases, offsite if offsite sewers are required as part of the development approval requirements. If any of the proposed sewers tie into existing sewer mains whose integrity is questioned

during the design phase of the project, then they too shall be television inspected in accordance with the following requirements.

- (a) The developer or his/her contractor shall furnish all labor, power, electronic equipment, and technicians to perform the closed circuit television of the sewers. Operation of the equipment shall be controlled from above ground with a skilled technician at the control panel in the television studio controlling the movement of the television camera. The technician shall have the capability to adjust the brilliance of the built-in lighting system and to be able to change the focus of the television camera by remote control. The built-in lighting system shall be capable of producing at least 100 footcandles of light. Picture quality shall be sufficient to produce a continuous 600 line resolution picture showing the entire inside periphery of the pipe.
- (b) The video seen by the television camera shall be transmitted to the monitor of not less than 14" measured diagonally. The monitor shall be located inside a heated and air conditioned mobile TV studio or in a trailer type unit sectioned off by a doorway from the outside noise and light.
- (c) The television inspection shall be performed by pulling the television camera through the section of the sewer along the axis of the pipe at a speed of approximately 12FPS, or as approved by the Engineer. The inspection shall be performed in a forward and/or backward direction as dictated by the line conditions at the time of inspection. During inspection of the pipe, every possible means shall be taken to ensure total viewing of the inside periphery of the pipe.
- (d) The M.T.M.U.A.'s inspector shall be scheduled 48 hours in advance and must be present during the television inspection. Comfortable seating arrangements shall be furnished for the inspector and he shall have access to fully view the television screen at all times. The technician shall provide narrated videotapes of the pipe inspection. Narrated videotape shall be VHS format at Standard Play (SP). In addition to the videotapes, television inspection log reports, 2 copies (one hand written and later one typed a day later), shall be submitted to the M.T.M.U.A.'s

inspector at the close of work each day with the following information:

(1) Video Tapes:

- (i) Shall be narrated and contain all stationing (footages), sewer lateral tee wyes, deep house connections, manhole numbers, and any deficiencies encountered.
- (ii) Date, time, project name, digital readout of footage inspected along pipe, pipe size, pipe material, manhole to manhole number, and street name shall be shown digitally in the television screen to be recorded on tape.

(2) Inspection Logs:

- (i) The log reports shall locate and describe at various stations (footages) sewer lateral tee wyes, deep house connections, manhole to manhole numbers and any deficiencies encountered. The log reports shall be written in clear, legible detail to determine the condition of the pipe without having to review the videotape. The log reports shall be cross referenced with videotapes with tape number, manhole number, tape footage with respect to a manhole number, actual distance from manholes to lateral connections, deep house connections, and any defects encountered.

e. Table II Gravity Sewer Pressure Test For Sdr-35 Pvc & Cip, Dip, And Rcp, Specification Time Required For A 0.5 Psig Pressure Drop For Size And Length Of Pipe Indicated For Q = 0.0015

1 Pipe Diameter (in.)	2 Minimum Time (min: sec)	3 Length for Minimum Time (ft)	4 Time for Longer Length (sec)	Specification Time for Length (L) shown (min:sec)								
				100 ft	150 ft	200 ft	250 ft	300 ft	350 ft	400 ft	450 ft	
4	1:53	597	.190 L	1:53	1:53	1:53	1:53	1:53	1:53	1:53	1:53	:53
6	2:50	398	.427 L	2:50	2:50	2:50	2:50	2:50	2:50	2:50	2:51	3:12

8	3:47	298	.760 L	3:47	3:47	3:47	3:47	3:48	4:26	5:04	5:42
10	4:43	239	1.187 L	4:43	4:43	4:43	4:57	5:56	6:55	7:54	8:54
12	5:40	199	1.709 L	5:40	5:40	5:42	7:08	8:33	9:58	11:24	12:50
15	7:05	159	2.671 L	7:05	7:05	8:54	11:08	13:21	15:35	17:48	20:02
18	8:30	133	3.846 L	8:30	9:37	12:49	16:01	19:14	22:26	25:38	28:51
21	9:55	114	5.235 L	9:55	13:05	17:27	21:49	26:11	30:32	34:54	39:16
24	11:20	99	6.837 L	11:24	17:57	22:48	28:30	34:11	39:53	45:35	51:17
27	12:45	88	8.653 L	14:25	21:38	28:51	36:04	43:16	50:30	57:42	64:56
30	14:10	80	10.683 L	17:48	26:43	35:37	44:31	53:25	62:19	71:13	80:07
33	15:35	72	12.926 L	21:33	32:19	43:56	53:52	64:38	75:24	86:10	96:57
36	17:00	66	15.384 L	25:39	38:28	51:17	64:06	76:55	89:44	102:34	115:23

All lines from manhole to manhole shall be lamped for alignment. The applicant's contractor shall pass a device through the pipe that will check for excessive vertical deflection. A pipe that has deflected more than 5% of its base internal diameter has deflected excessively. The test shall be conducted a minimum of thirty (30) days after installation.

The deflection device or mandril for checking the deflection shall be provided by the applicant's contractor. Details of the deflection device or mandril shall be submitted to the M.T.M.U.A.'S engineer for approval, prior to its use and shall be fabricated and based on the following table:

f. Table IIA

PIPE SIZE	MANDRIL SIZE		BASE I.D.		O.D.	
	SMOOTH WALL	RIB PIPE	SMOOTH WALL	RIB PIPE	SMOOTH WALL	RIB PIPE
8"	7.28	7.25	7.665	7.637	8.40	8.80
10"	9.08	9.05	9.563	9.529	10.50	11.00
12"	10.79	10.75	11.361	11.322	12.50	13.098
15"	13.20	13.16	13.898	13.849	15.00	16.043
18"	16.13	16.15	16.976	17.003	18.701	19.626

21"	19.00	18.99	20.004	19.985	22.047	23.102
24"	21.36	21.48	22.48	22.613	24.803	26.142
27"	24.06	24.22	25.327	25.490	27.953	29.563

Note that the deflection device shall be pulled through the pipeline using only the force of one (1) person without the aid of any devices other than the rope/chain attached to the deflection device.

Should any test section of pipe fail to meet the testing criteria, the applicant's contractor shall, at his/her own expense, locate, and replace defective pipe section until specified criteria are met.

g. Gravity Sewer Pressure Test For Clay Pipe; Table III.

1. Gravity Sewer Pressure Test For Clay Pipe

Specification time required for a 1.0 PSIG pressure drop for size and length of pipe indicated for $Q=0.000371$.

(a) Test Procedure.

- (1) Clean pipe to be tested using high pressure jet truck and appurtenant cleaning fittings and nozzles prior to testing.
- (2) Plug all pipe outlets with suitable test plugs. Brace each plug securely.
- (3) If the pipe to be tested is submerged in ground water, insert a sump pipe along side a manhole during the backfill procedure making sure sump pipe is at least 4" in diameter and end of sump pipe is in crushed foundation stone of manhole bedding. After testing, sump pipe to be filled with clean crushed stone and cut off 12" below subgrade. This sump pipe shall determine the ground water pressure on pipe installed by measuring how much ground water is present above the invert of the clay pipe. The air pressure correction which must be added to the 3 PSIG normal test starting pressure

400	70	158													
450	79	170													
500	88														
550	97														
600	106														
650	113	170	227	283	340	425	510	595	680	765	851	935	1020	1105	

NOTE: TO BE USED WHEN TESTING ONE DIAMETER ONLY

i. Table IV.

		LENGTH OF MAIN LINE IN FEET											8" DIAMETER			
		25	50	75	100	125	150	175	200	225	250	275	300	400	500	
4" DIAMETER	25	22	40	57	75	92	110	128	145	163	180	198	216	223	224	
	50	26	44	62	79	97	114	132	150	167	185	202	218	220	221	
	75	31	48	66	84	101	119	136	154	172	189	207	214	217	219	
	100	35	53	70	88	106	123	141	158	176	194	209	211	214	216	
	125	40	57	75	92	110	128	145	163	180	198	206	207	211	214	
	150	44	62	79	97	114	132	150	167	185	201	202	204	209	212	
	175	48	66	84	101	119	136	154	172	189	197	199	201	206	210	
	200	53	70	88	106	123	141	158	176	192	194	197	199	204	208	
	225	57	75	92	110	128	145	163	180	189	192	194	196	202	206	
	250	62	79	97	114	132	150	167	183	186	189	191	193	200	204	
	275	66	84	101	119	136	154	172	181	184	187	189	191	198	202	
	300	70	88	106	123	141	158	174	178	181	184	187	189	196	200	
	350	79	97	114	132	150	166	170	174	177	180	183	185	192	197	
	400	88	106	123	141	157	162	166	170	174	176	179	181	189	194	
	450	97	114	132	148	154	159	163	167	170	173	176	178	186	191	
500	106	123	140	146	151	156	160	164	167	170	173	175	183	189		

j. Table V.

		LENGTH OF MAIN LINE IN FEET											10" DIAMETER			
		25	50	75	100	125	150	175	200	225	250	275	300	400	500	
Length of lateral in feet	4" DIAMETER	25	32	59	87	114	142	169	197	224	252	277	277	278	279	280
		50	36	64	91	119	146	174	201	229	256	271	272	273	275	277
		75	41	68	96	123	151	178	206	233	261	265	267	268	272	274
		100	45	73	100	128	155	183	210	238	258	260	262	264	268	271
		125	50	77	105	132	160	187	214	242	253	255	257	259	264	268
		150	54	81	109	136	164	191	219	244	248	251	253	255	261	265
		175	58	86	113	141	168	196	223	239	243	246	249	251	258	262
		200	63	90	118	145	173	200	228	235	239	242	245	248	255	260
		225	67	95	122	150	177	205	226	231	235	239	242	244	252	257

		250	72	99	127	154	182	209	222	227	231	235	238	241	249	255
		275	76	103	131	158	186	211	218	223	228	231	235	238	247	253
		300	80	108	135	163	190	208	214	220	224	228	232	235	244	250
		350	89	117	144	172	194	201	208	213	218	222	226	229	239	246
		400	98	125	153	179	188	196	202	208	213	217	221	224	235	242
		450	107	134	162	174	183	191	197	203	208	212	216	220	230	238
		500	116	143	160	170	179	186	193	198	203	207	212	215	226	235

k. Table VI.

		LENGTH OF MAIN LINE IN FEET										12" DIAMETER				
		25	50	75	100	125	150	175	200	225	250	275	300	400	500	
Length Of lateral in feet	4"DIAMETER	25	44	84	123	163	202	242	282	321	332	333	334	334	336	336
		50	48	88	128	167	207	246	286	323	324	326	327	328	331	333
		75	53	92	132	172	211	251	290	316	317	319	321	323	327	329
		100	57	97	136	176	216	255	295	308	311	313	316	317	323	326
		125	62	101	141	180	220	260	297	301	304	308	310	312	319	323
		150	66	106	145	185	224	264	290	295	299	302	305	308	315	319
		175	70	110	150	189	229	268	283	289	293	297	300	303	311	316
		200	75	114	154	194	233	271	277	283	288	292	296	299	308	313
		225	79	119	158	198	238	265	272	278	283	288	291	295	304	310
		250	84	123	163	202	242	259	267	273	278	283	287	291	301	308
		275	88	128	167	207	244	254	262	269	274	279	283	287	298	305
		300	92	132	172	211	239	249	257	264	270	275	279	283	295	302
		350	101	141	180	218	231	241	249	256	262	268	272	276	289	297
		400	110	150	189	210	223	233	242	249	255	261	266	270	283	292
		450	119	158	189	204	216	227	235	243	249	255	260	264	278	288
		500	128	166	184	198	210	221	229	237	243	249	254	259	273	283

i. Table VII.

		LENGTH OF MAIN LINE IN FEET										15" DIAMETER				
		25	50	75	100	125	150	175	200	225	250	275	300	400	500	
Length Of lateral in feet	4"DIAMETER	25	66	128	190	252	314	376	414	415	416	417	418	418	420	421
		50	71	133	194	256	318	380	403	406	408	409	411	412	415	417
		75	75	137	199	261	323	385	393	397	400	402	404	406	410	413
		100	80	141	203	265	327	378	384	388	392	395	397	400	406	409
		125	84	146	208	270	331	369	375	380	385	388	391	394	401	406
		150	88	150	212	274	336	360	367	373	378	382	385	388	397	402
		175	93	155	216	278	340	351	359	366	371	376	380	383	392	398
		200	97	159	221	283	332	343	352	359	365	370	374	378	388	395

		225	102	163	225	287	324	336	345	353	359	365	369	373	384	392
		250	106	168	230	292	317	329	339	347	353	359	364	368	380	388
		275	110	172	234	293	310	323	333	341	348	354	359	364	377	385
		300	115	177	238	287	303	316	327	336	343	349	354	359	373	382
		350	124	185	247	275	292	305	316	325	333	340	346	351	366	376
		400	132	194	242	264	281	295	306	316	324	332	338	343	359	370
		450	141	203	233	255	272	286	298	308	316	324	330	336	353	365
		500	150	199	225	247	264	278	290	300	309	316	323	329	347	359

m. Table VIII.

		LENGTH OF MAIN LINE IN FEET											18" DIAMETER			
		25	50	75	100	125	150	175	200	225	250	275	300	400	500	
Length Of lateral in feet	4"DIAMETER	25	94	183	272	361	450	496	498	499	501	502	502	503	505	506
		50	98	187	276	365	454	483	487	489	492	493	495	496	499	502
		75	102	191	281	370	459	470	476	480	483	485	488	489	494	497
		100	107	196	285	374	450	459	465	470	475	478	481	483	489	493
		125	111	200	289	378	438	448	456	462	467	470	474	477	484	489
		150	116	205	294	383	427	438	446	453	459	463	467	471	480	485
		175	120	209	298	387	416	428	438	445	452	457	461	465	475	481
		200	124	213	303	388	406	419	430	438	445	450	455	459	470	478
		225	129	218	307	378	397	410	422	431	438	444	449	453	466	474
		250	133	222	311	369	388	402	414	424	431	438	443	448	462	470
		275	138	227	316	360	380	395	407	417	425	432	438	443	457	467
		300	142	231	320	352	372	387	400	411	419	426	433	438	453	463
		350	151	240	308	337	358	374	388	399	408	416	422	428	445	457
		400	160	249	295	323	345	362	376	388	397	406	413	419	438	450
		450	168	246	283	312	333	351	365	378	388	396	404	411	430	444
		500	177	235	273	301	323	341	355	368	379	388	396	403	423	438

n. Table IX.

		LENGTH OF MAIN LINE IN FEET											21" DIAMETER			
		25	50	75	100	125	150	175	200	225	250	275	300	400	500	
Length Of lateral in feet	4"DIAMETER	25	126	247	368	490	577	581	582	584	585	586	587	588	590	591
		50	130	251	373	494	561	567	570	573	576	578	579	581	584	586
		75	135	256	377	498	545	553	559	563	567	569	571	574	579	582
		100	139	260	381	503	531	541	548	553	558	561	564	567	573	578
		125	143	265	386	503	518	529	537	544	549	553	557	560	568	573
		150	148	269	390	488	505	518	527	535	541	546	550	553	563	569
		175	152	273	395	475	493	507	518	526	533	538	543	547	558	565

		200	157	278	399	462	482	497	509	518	526	531	536	541	553	561
		225	161	282	403	450	472	448	500	510	518	524	530	535	548	557
		250	165	287	408	439	462	479	492	502	511	518	524	529	544	553
		275	170	291	397	429	452	470	484	495	504	511	518	523	539	549
		300	174	295	387	420	443	462	476	488	498	505	512	518	535	546
		350	183	304	368	402	427	446	462	474	485	493	501	507	526	538
		400	192	304	352	386	412	432	448	462	473	482	490	497	518	531
		450	201	291	338	372	398	419	436	450	462	472	480	488	510	524
		500	209	279	325	360	386	407	425	439	452	462	471	479	502	518

o. Table X.

		LENGTH OF MAIN LINE IN FEET										24" DIAMETER				
		25	50	75	100	125	150	175	200	225	250	275	300	400	500	
Length Of lateral in feet	4"DIAMETER	25	163	321	480	638	662	665	667	669	670	671	672	673	674	676
		50	167	326	484	637	645	650	654	658	660	662	664	665	669	671
		75	172	330	488	617	629	636	642	647	650	653	656	658	663	666
		100	176	334	493	599	613	623	631	637	641	645	648	650	658	662
		125	180	339	497	582	599	611	620	627	632	637	640	643	652	658
		150	185	343	502	567	585	599	609	617	623	623	633	636	647	653
		175	189	348	506	552	573	588	599	608	615	615	626	630	642	649
		200	194	352	506	538	560	577	589	599	607	607	619	623	637	645
		225	198	356	492	525	549	566	580	591	599	599	612	617	632	641
		250	202	361	478	513	538	556	571	582	591	591	605	611	627	637
		275	207	365	465	501	528	547	562	574	584	592	599	605	622	633
		300	211	370	454	491	518	538	554	567	577	585	593	599	617	629
		350	220	375	432	471	499	521	538	552	563	573	581	588	608	621
		400	229	356	413	453	482	505	523	538	550	560	569	577	599	613
		450	238	340	397	436	467	491	509	525	538	549	558	566	590	606
		500	244	326	382	422	453	477	497	513	526	538	548	556	582	599

p. Leakage.

Any new pipe, joint or other part of the sewer construction found to show leakage in excess of the permissible limit shall be removed and replaced.

q. Pressure Testing of Force Mains.

1. Non-residential requirements for pressure testing of force mains are as follows:

Prior to making pressure tests, the force main must be complete; including, but not limited to, air release assemblies, blow off assemblies, valves and all connections to pumping stations. Where lines are located in paved areas, the base course must be constructed, as-builts reviewed by the M.T.M.U.A., permit to operate (4 copies of WQM 005 and MUA certification) delivered to the Authority for approval, and all punch list item completed prior to testing. The pipe shall be filled with clean water for at least twelve hours. After absorption is complete, the pipe shall be tested under a pressure to twice the maximum working pressure or 150 PSI whichever is greater, except that the manufacture's rated test pressure shall not be exceeded. No leakage will be permitted over a two hour period. Prior to pressure tests, the contractor shall provide all work, labor and materials necessary to perform a continuity test of the trace wire. Any discontinuities found shall be repaired in accordance with these rules and regulations. The applicant's contractor shall furnish all labor, material and equipment necessary for testing.

2. For residential developments, pressure and leakage of force main pipe testing shall be determined by AWWA C600. Any pipe, joint, or other part of the force main construction found to show leakage shall be repaired, or removed and replaced.

r. Requirements for Pressure Testing.

The requirements for pressure testing of pump stations and treatment plants shall be as follows:

1. The contractor shall supply materials, labor and equipment for testing of H.V.A.C. mechanical, plumbing and electrical systems.
2. The contractor shall coordinate the tests with the owner and shall insure that the procedures of the test do not interrupt or otherwise affect the owner's operation.
3. System testing shall consist of the sequential concurrent testing of all components of a system to demonstrate compliance with the operating sequences, functional interlocks, protective interlocks and alarms required by the project specifications.
4. Testing of individual components may be scheduled concurrently with the system testing.
5. The contractor shall coordinate the test with the respective manufacturers and shall notify the Monroe Township M.T.M.U.A. Staff Engineer in writing, ten days before the testing date.

6. Testing shall be performed in the presence of the M.T.M.U.A. inspection personnel and manufacturer's representatives for the equipment being tested.
7. The manufacturer's representatives present during the test shall be qualified to adjust and operate the respective components and shall be prepared to adjust the instruments and equipment as needed to insure continuity of the test.
8. Before the test, the contractor shall verify that the individual equipment and instruments are adjusted to the required settings.
9. Before testing each system in the presence of the M.T.M.U.A. inspection personnel, the contractor shall run a trial test to insure that the witnessed test can be performed without major interruption.
10. During the performance of the tests, the contractor shall keep accurate records of all items tested listing each required function, sequence and interlock.
11. Main sewage pumps shall be tested recirculating clean water back to wet well. Testing of This system should follow individual components testing. Included in This system test is main sewage pumps, reduced voltage starters, pump control panels, reduced voltage starter panels, instrument panel, standby generator, automatic transfer switch, liquid level sensors, and alarm systems. Wet well levels shall be simulated by manipulating liquid level sensors.
12. During main sewage pump testing the pumps and motors shall be checked for the following items:
 - (a) Pump and motor vibration.
 - (b) Pump and motor upper and lower bearing temperature.
 - (c) Pump and motor selector switch in three positions: Hand, Off and Automatic.
13. Simulate power failure with all pumps running. Check that pumps restart with power return. Check that lag pump restarts after time delay period.
14. Simulate power failure. Check that emergency standby generator takes over and restarts pump after adjustable time delay period.
15. Simulate all pump/motor selector switch modes of operation.

16. Testing of piping systems shall be as follows:
 - (a) Clean, bacteria safe water shall be used in all hydrostatic testing.
 - (b) Pipe sections shall be tested prior to connecting the specified equipment if such equipment will interfere with the tests.
 - (c) Pressure testing will be considered acceptable when the test pressure has been achieved and maintained for the duration of the test period without leaks.
 - (d) Leaks developed during the test period shall be promptly repaired and the test shall be repeated until the requirements are met.
 - (e) Faulty joints shall be replaced (repaired only by approval of M.T.M.U.A. Staff Engineer) to the extent of disassembling and remaking a joint and replacing defective pipe sections and fittings. The use of clamps, grout or other temporary means shall not be acceptable.
 - (f) The contractor shall supply his/her own closure devices and plugs for performing the tests. The use of specific valves, equipment or other line appurtenances shall be approved by the M.T.M.U.A. Staff Engineer.
 - (g) Prior to testing, the contractor shall ensure that all pipe accessories and equipment line valves, gauges, switches, etc., that are not rated for the test pressures are removed.
17. Hydrostatic testing and pressure testing valves of piping systems are as follows: All PVC pressure and ductile iron pipe, valves, pumps and appurtenant iron fittings shall be tested to 150 psi for 2 hours with 0 leakage.
 - (a) Pressure testing of control piping, PVC, copper lines under 1" diameter shall be tested to double the working pressure for two hours if not otherwise shown or specified.
18. Prior to testing, the lines shall be thoroughly cleaned and filled with water for a period of not less than 24 hours. After This period the lines shall be subjected to the required test pressures with zero leakage.
19. Heating, ventilation, air conditioning system tests shall be as follows:

- (a) The new system shall be tested and it shall be established that quantities are calibrated accurately and performing satisfactorily and that the thermostats, motors, controls, and fans are working satisfactorily. The system shall be checked for vibration, excessive noise, operating temperatures, and all such conditions corrected.

20. Electrical tests shall be as follows:

- (a) Performance tests shall consist of first class workmanship in every respect.
- (b) The contractor shall furnish all test equipment and a qualified manufacturer's start-up engineer to properly perform all tests required.
- (c) Electrical circuits shall be tested to ensure circuit continuity, insulation resistance, proper splicing, and freedom from improper grounds.
- (d) Necessary adjustments shall be made in cooperation with the respective manufacturers and other contractors when necessary. All tests shall be made in accordance with the latest standards on ANSI, IPCEA, IEEE, and NEMA.

21. Electrical tests for 600V and below equipment is as follows:

- (a) Each panel shall be tested with mains disconnected, branch circuit breakers closed, all fixtures in place and permanently connected, lamps removed or omitted from the sockets, and all wall switches closed. Feeders shall be tested with the feeders disconnected from the panel. Each individual power circuit shall be tested at the panel or motor starter with the power equipment connected for proper operation.
- (b) "Megger" tests of the insulation resistance of rotating machines and power feeders shall be conducted. The results will be accepted when the Megger shows the insulation resistance to be not less than one megohm per 100 volts at 20 degrees centigrade using a 1000 volt Megger. All Megger tests for motors and cables shall be turned over to the owner.
- (c) Transformers shall be shall be meggered in accordance with the manufacturer's recommendations.

- (d) The grounding system shall have a resistance to ground of 0.5 ohms or less when measured by a "Megger" or equivalent device.
- (e) The 230/460 3 phase equipment shall not be energized until all tests and adjustments have been made to the satisfaction of the RPI Transformers.
- (f) All tests shall be witnessed by the M.T.M.U.A. Engineering Staff. The cause of any failure shall be impartially examined by the Staff Engineer and the results shall be binding on the contractor, if in the Staff Engineer's judgment such failure was caused by poor workmanship during installation by the contractor.
- (g) It shall be the contractor's responsibility to perform any and all additional tests as required by vendors for their equipment, inspection agencies as requested or any other test so called for in these rules and regulations but not listed in this section.
- (h) The electrical equipment shall be given an operational test to determine that all components including motors, controls, reduced voltage starters, standby generator, automatic transfer switch and auxiliary associated equipment are in operable condition and can function as described and shown in the relevant specifications, operating instructions and on the drawings.
- (i) Motor current reading shall be taken at full load or as close to full load as the driven machine will develop. If the ammeter reading is over the rated full load current, determine the reason for the discrepancy and take the necessary corrective action.
- (j) The cause of any motor operating above full load rating shall be removed instead of increasing the overload relay trip rating.
- (k) Check the load current in each phase of each distribution panel feeder and make modifications to the circuit loading to correct load unbalance to within one (1) KVA phase to phase for distribution panels.
- (l) After completion of the work, the contractor shall thoroughly test the entire electrical system, including electrical work required for control and power, and shall adjust as required.

22. System performance test runs shall be as follows:
 - (a) Coordinate test runs of electrical systems, mechanical systems, plumbing systems, heating and ventilating systems, etc.
 - (b) Check each item in each system to determine that it is set for proper operation. With Staff Engineer present, operate each system in a test run of appropriate duration to demonstrate compliance with performance requirements. During or following test runs, make final corrections or adjustments of systems to refine and improve performance where possible, including noise and vibration reductions, elimination of hazards, better response of controls, signals and alarms, and similar system performance improvements. Provide testing or inspection devices requested for the Staff Engineer's inspection of actual system performance. Demonstrate that controls and items requiring service or maintenance are accessible.
23. General training of owner's personnel with six (6) sets of operating instructions and manuals shall be given on a separate day and notice given to the M.T.M.U.A. one week in advance to schedule the training session.

S:7 AS-BUILT DRAWINGS, EASEMENT MAPS, DESCRIPTIONS AND MANUALS.

S:7-1 Required.

During construction, the contractor's surveyor shall survey the slope and grades weekly or every 1000 l.f. of progress of construction, rather than waiting for completion of the project. Before final acceptance or reduction of Performance Bonds by the Authority, the applicant is required to submit as-built information in the following form:

- a. After Construction, Before Preliminary Punch Lists.

After construction of the sewer main but before the Authority issues preliminary construction punch lists, before sewer main and laterals with cleanouts are pressure tested, and before sewer main may be used, the applicant shall furnish two (2) sets of prints (blue on white). Additionally, maps shall also be supplied in digital format and the digital data shall comply with all NJDEP Mapping and Digital Data Standards and/or NJDEP GPS Data Collection Standards for GIS Data Development requirements. These prints shall show as-built alignment and grade of sewer main, offsets to easement boundaries (if applicable), deeds and descriptions (if applicable), locations of other utilities (gas, electric,

telephone, cable TV, storm sewers, etc.), stationary light poles, transformers, pads, telephone boxes, and concrete encasements, indicating clearance dimensions to the utility crossed. The Authority may require the verification of other utilities locations which appear to be closer than the required design separation via test pits. Should any of these stationary items be located 3' apart or closer, then those stationary objects shall be relocated to the 5 foot offset. Upon completion of the above, the applicant may activate and use the sewer main (inspector must be present during removal of masonry bulkhead) but not tie the cleanout to the proposed building until paragraph b below of this section is completed.

b. Plumbing Completed to Curb Line.

After construction of the building with all plumbing from the building completed to the newly constructed and tested sewer lateral cleanouts, the applicant shall, every calendar year:

1. Furnish individual plot plans containing building foundation outline, triangulations from foundation outline to sewer cleanout and related items further described under paragraph d. below.
2. As long as two or more homes have been constructed, the applicant will submit, every calendar year, updated full size plan sheets with the same information required under paragraph d. below. Additionally, maps shall also be supplied in digital format that meet the NJDEP GPS Data Collection Standards for GIS Data Development requirements. Upon completion of those items, the applicant may request from the Authority their endorsement of the request for Certificate of Occupancy.

(Revised 7-17-03)

c. Certificates of Occupancy.

After 95% of the Certificates of Occupancy in the proposed development have been endorsed by the Authority, the applicant shall submit full size plan view and full size plan and profile view plans with the same information provided under paragraphs a. and b. above, containing all items outlined under paragraph d. below. Additionally, maps shall also be supplied in digital format that meet the NJDEP GPS Data Collection Standards for GIS Data Development requirements.

d. Project Completion Prior to Final Acceptance.

At completion of the project but before final acceptance by the Authority, the applicant shall submit one (1) complete set of reproducibles, approved by the Authority's Engineer, and four (4) sets of prints (blue on

white) of each drawing showing the details of the collection system, all facilities, connections, etc., as actually constructed in plan view and plan and profile view. The data including depth of cleanout at each curb, length of lateral from cleanout to sewer main, location by GPS and triangulation of cleanout, tee wye, deep house connection 4" tee and any manhole not in pavement, stationing of laterals and deep house connections, elevations of deep house connections 4" tee in profile, upstream and downstream manhole data, sewer main distance and slope calculations based on revised manhole inverts. Show underground electric, telephone, gas, cable TV, storm sewer, concrete encasements and their clearance dimensions with other utilities or storm sewers, any above ground structures (transformer bases, telephone ground boxes, etc.) if they are within 3' of sewer mains or laterals, stationing of laterals, deep house connections based on sewer centerline stationing. Stationing will always begin 0+0 at downstream manhole to upstream manhole. Offsets to sewer mains required in easements from easement boundary line. All features shall be physically located using GPS technology and referenced to New Jersey State Plane Coordinate System, NAD '83. Additionally, maps shall also be supplied in digital format that meet the NJDEP GPS Data Collection Standards for GIS Data Development requirements.

S:8 USE OF SYSTEM PRIOR TO ACCEPTANCE.

S:8-1 Satisfactory Completion.

After satisfactory completion of all facilities proposed, and before use, the Authority shall be in receipt of the following:

- a. The facilities shall be final tested.
- b. As-Builts
- c. All test certifications and permits to operate shall be given to the Authority.
- d. Easements
- e. N.J.D.E.P. Permits to Operates (4 originally signed copies)
- f. Approvals from all other agencies as applicable.

S:9 ACCEPTANCE OF NEW SEWER SYSTEM BY THE AUTHORITY.

S:9-1 Requirements for Acceptance; Satisfactory Completion.

- a. After satisfactory completion of all facilities proposed, including roadways final paved, all sewer easements restored, and landscaped according to project drawings and Township requirements, and prior to acceptance by the Authority, the Applicant will:
 1. Give proper title to all lands, easements, structures, appurtenances and improvements by deed or appropriate dedication.
 2. Post a Maintenance Guarantee in a form acceptable to the Authority's attorney and equal to 10% of the Performance Guarantee guaranteeing the satisfactory performance of the system for a period of two (2) years. The guarantee may be either:
 - (a) 10% cash and 90% acceptable bond or Letter of Credit or
 - (b) 100% Letter of Credit.
 3. Prior to acceptance by the Authority the applicant's engineer will certify to the Authority, and the State where necessary, that all plans and specifications were prepared in conformance with the Authority's Rules and Regulations and with N.J.D.E.P. requirements, that actual construction costs are not significantly different than the originally submitted cost estimates, and that construction has been in conformance with the approved Plans and Specifications and in full compliance with the Authority's Rules and Regulations.
 4. Where required, the Authority's Engineer will certify to the State that the system has been inspected and tested in accordance with and complies with all State performance standards and regulations.

S:9-2 Approval.

- a. Upon receipt and approval of the above listed items, the Authority will:
 1. Release the applicant from the Performance Guarantee.
 2. Accept the title to all lands, easements, structures, appurtenances and improvements.
 3. Assume the operation and maintenance of the system thereafter.

S:9-3 Partial Reduction of Performance Guarantee.

The developer may request not more than one reduction in the amount of the Performance Guarantee and only when in excess of 50% of the improvements to be installed are completed, i.e. tested and activated. The reduction shall only be made upon favorable recommendation of the Authority's Engineer and shall not exceed 70% of the dollar value of the improvements installed.

S:10 REQUIREMENTS AS TO WASTE DISCHARGE INTO SEWERS.

S:10-1 Industrial Wastes.

a. Approval.

Prior written approval shall be obtained from the Authority in order to discharge in the sewerage wastes containing any of the following:

1. A five (5) day B.O.D. greater than two hundred (200) mg/l; or
2. A suspended solids content greater than two hundred and fifty (250) mg/l; or
3. A chlorine demand greater than fifteen (15) mg/l; or
4. Any quantity of substances as described in Section S:10-3, "Prohibited Wastes".

b. Industrial Users.

Industrial users may, at the option of the Authority, be required to execute an individual contract with the Authority for sewerage service. Said contract may contain special conditions relating to pretreatment, metering, sampling or additional requirements as the Authority deems necessary and appropriate for the protection and proper operation of its sewerage system.

S:10-2 Pretreatment, Odor Control, Metering and Sampling of Industrial Wastes.

a. Pretreatment of Wastes.

Whenever necessary, in the opinion of the Authority's Engineer, the applicant shall provide at his/her own expense such facilities for pretreatment of industrial wastes as may be necessary to:

1. Reduce five (5) day B.O.D. to two hundred (200)mg/l, suspended solids to two hundred fifty (250) mg/l, chlorine demand to fifteen (15) mg/l, or
2. Reduce objectionable characteristics or constituents to conform to the maximum limits permitted in these Rules and Regulations; or
3. Provide equalization of discharge over a 24 hour period to prevent temporary overloading of the Authority's treatment or conveyance facilities.
4. Odor control in the form of Bioxide chemical feed with pumps, tanks and controls or as determined by the M.T.M.U.A Engineer.

b. Sampling

1. Whenever necessary, in the opinion of the Authority's Engineer, the applicant shall provide at his/her own expense a suitable precast chamber with cast in place Bilco doors model J-2AL with stainless steel hardware, two Bilco ladder up safety posts model LU-2, ISCO model no. 2870 bubbler type flow meter, ISCO model 2700 sequential sampler; and the following appurtenances for observation, metering, and sampling of waste materials:
 - (a) One (1) ISCO model 2700 sequential sampler with glass bottles part no. 68-2700-002.
 - (b) One (1) nicad battery part no. 60-1684-040.
 - (c) One (1) battery charger part no. 60-3004-059.
 - (d) One (1) 3/8" I.D. x 25' teflon suction tubing part no. 60-2703-114.
 - (e) One (1) S.S. strainer part no. 60-1684-110.
 - (f) One (1) ISCO 22' connection cable from sampler to flow meter part no. 60-1874-032.
 - (g) One (1) ISCO model 2870 portable bubbler type flow meter part no. 68-2870-001.
2. Depending upon peak design flow either of the following Palmer Bowles flumes must be cast into precast meter pit channel:

	<u>Minimum Flow</u>	<u>Maximum Flow</u>
4" Palmer Bowles	1/3 GPM	84 GPM
6" Palmer Bowles	9/10 GPM	232 GPM

8" Palmer Bowles

1.8 GPM

475 GPM

c. Plans and Specifications.

Plans, specifications, and all other pertinent information relating to proposed facilities for pretreatment, metering or sampling of industrial wastes shall be submitted to the Authority for approval. No construction shall be permitted until written approval has been granted by the Authority and all governmental regulatory bodies having jurisdiction.

d. Accessibility.

Pretreatment, metering and sampling facilities shall be accessible to the Authority's authorized agent at all times. The applicant may, at the option of the Authority, be required to grant title to said facilities to the Authority in order to insure the proper operations or maintenance thereof.

S:10-3 Prohibited Wastes.

No person shall discharge or cause to be discharged any storm water, surface water, ground water, roof runoff, subsurface drainage or discharge from a sump pump into any sanitary sewer. Except as otherwise provided in these Rules and Regulations, no person shall discharge or cause to be discharged any of the following described wastes or waters into the Sewer System:

- a. Any liquid or vapor having a temperature higher than one hundred and fifty (150) degrees Fahrenheit.
- b. Any water or waste containing more than one hundred (100) ppm by weight of fats, oils, or grease.
- c. Any gasoline, benzene, naphtha, fuel oil or other flammable or explosive liquid, solid or gas which, by reason of its nature or quality, may cause fire or explosion or which, in any other way, may be injurious to persons or the Sewer System.
- d. Any noxious or malodorous gas or substance which, either singly or by interaction with other wastes, shall be capable of creating a public nuisance or hazard to life or of preventing entry into any sewer for maintenance and repair.
- e. Any garbage, except properly shredded or ground garbage.
- f. Any solid or viscous substance which shall be capable of causing obstruction of the flow in any sewer or other interference with the proper operation of the Sewer System.

- g. Any water or waste having a pH lower than 5.5 or higher than 8.5 or having any corrosive property capable of causing damage or hazard to structures or equipment of the Sewer System or to personnel engaged in operation and maintenance thereof.
- h. Any water or waste containing any toxic substance in quantity sufficient to constitute a hazard to humans or animals.
- i. Discharges containing B.O.D. in excess of two hundred (200) mg/l or S.S. in excess of two hundred and fifty (250) mg/l or having chlorine demand greater than fifteen(15) mg/l unless prior written approval from the M.T.M.U.A. is obtained first.
- j. Any toxic radioactive isotopes, except by special permission of the Authority.
- k. Cesspool or septic tank contents.
- l. Any waters or wastes containing concentrations of materials in excess of the following limits.

<u>Material</u>	<u>Maximum Concentration (mg/l)</u>
Arsenic	0.1
Cyanide	0.2
Lead	0.3
Cadmium, Hexavalent Chromium, Copper, Nickel, Tin, Zinc	1.0
Fluorides, Iron	5.0
Hydrogen Sulfide	0.1

- m. Any hazardous waste as defined by the New Jersey Administrative Code, Sections 7:26-1.4 and 7:26-8.1 et. seq.
- n. Any materials in concentrations specifically prohibited by M.C.U.A. Rules and Regulations.

S:10-4 Control of Grease.

- a. Parameters.

As defined in Section S:10-3, Prohibited Wastes, of these regulations, no person shall discharge or cause to be discharged into the Sewer System, any water or waste containing more than one hundred (100) ppm by weight of fats, oils or grease. Despite such regulations, the Authority continues to experience the buildup of these materials in the Sewer System which result in a loss of capacity, blockages, and additional costs for their removal.

b. Control.

The Authority has determined that such discharges may be controlled and treated through the use of commercially available and tested bacteriological culture formulations and through the proper operation and maintenance of grease traps. The Authority has determined the need to adopt the regulations contained herein, as a means of controlling both existing and proposed users of the Sewer System by requiring the generators of such discharges to limit their discharge of oils and grease to no more than 100 mg/l. This may be done by many means including, but not limited to, regular cleaning of their grease traps and treatment of their waste with bacteriological formulations.

1. The bacteriological formulations, if used, shall be live, viable bacteria and acceptable for use in a sewage system. The use of free-enzyme products is unacceptable. The formulations shall be capable of functioning over a wide range of operating parameters such as pH, temperature, and dissolved oxygen.

c. New Establishments.

New grease generating establishments, as defined, are required to make written application to the Authority for connection to the Sewer System. In addition to the submittal requirements as stipulated elsewhere in these regulations, the owner shall also furnish or cause to be furnished a detailed description of the type and size of the building, nature of the business or building use, the number and type of fixtures to be served, the type, volume and chemical characteristics of the waste to be discharged, design and pertinent data related to grease control devices, a plumbing diagram, and details of the sewer connection components. The method of submission and number of documents to be submitted shall be as defined elsewhere.

1. Any new grease generating establishments requiring a permit from the Township may be required to install an underground grease monitoring pit (in addition to grease traps or interceptors as may be required by other regulations) in accordance with the details contained in these regulations. The grease pits shall be installed for purposes of the Authority in obtaining samples for determining the quantity of grease being discharged into the Sewer System.

d. Existing Establishments.

Existing grease generating establishments shall be required to install within 60 days of notification by the Authority an underground grease monitoring pit (in addition to grease traps or interceptors as may be required by other regulations) in accordance with the details contained in

these regulations. The grease monitoring pits shall be installed for purposes of the Authority in obtaining samples for determining the quantity of grease being discharged into the Sewer System.

e. Provision and Maintenance of Monitoring Pits.

1. Grease monitoring pits shall be provided and maintained at the expense of the owner or tenant, in a continuous efficient operating condition. Grease monitoring pits shall be constructed of impervious materials, capable of withstanding abrupt and extreme changes in temperature. The unit(s) shall be watertight, precast concrete, and equipped with readily removable access covers, suitable for traffic loadings. Pits must be constructed entirely on the property of the Owner and shall be located as to be readily and easily accessible for cleaning.
2. Grease monitoring pits shall be designed to provide easy access for Authority personnel to collect a sufficient quantity of the wastewater discharge from the grease generating establishment without prior notice to owner or tenant. Details of an acceptable grease pit are included in these regulations.
3. Grease monitoring pits shall not be required for single, private family dwelling units. Grease monitoring pits must be located to provide for easy access for inspection by the Authority or the local Board of Health. Grease traps or interceptors, as may be required by Municipal Regulations, are installed either within or outside of the building whereas grease monitoring pits are to be located at a point on the sewer connection line as close as possible to the street main, at a location approved by the Authority.
4. Grease monitoring pits will be inspected by Authority personnel to insure proper maintenance and operation of the traps or interceptors. Inspections will be made during reasonable hours. Samples of the wastewater discharge will be taken and tested for grease. Should these inspections or any test results reveal unsatisfactory conditions, the owner and tenant will be notified in writing of the non-compliance and the Authority may assess a penalty as defined by these regulations.
5. The owner and/or tenant may add or cause to be added into each sanitary sewer line servicing such use, a bacteriological culture formulation approved by the Authority to control and treat such discharges. The application of such bacteriological culture formulation shall be in accordance with the manufacturer's specifications, unless otherwise directed by the Authority.

6. The Authority shall maintain a list of approved bacteriological culture formulations and furnish same upon request to any owner and/or tenant required the use of such formulation. The owners and/or tenants may submit or cause to be submitted additional formulations to the Authority for their approval.
7. The bacteria culture formulations shall be introduced into the owner's sewer line at such points and in such quantities as recommended by the manufacturer or supplier of the product. Preparation of the formulation, prior to introduction into the system, shall also be in accordance with the manufacturer's or supplier's recommendations.
8. All records required to be maintained hereunder shall be available for inspection by the Authority or its designee upon request. In addition, the Authority may require of any person or entity regulated by the provisions of this section to periodically submit such records to the Authority.
9. In the event it is determined that blockage of an Authority sewer main is a result of the discharge from any grease generating establishment, all costs incurred by the Authority will be charged to the owner and/or tenant. Such costs can include but are not limited to, cost of clearing the blockage; damages to sewer lines; administrative, legal, and engineering costs, cleanup of pollution to surrounding soils or water; and reimbursement of any penalties imposed by regulatory agencies. In the event the premises of the grease generating establishment are leased, copies of the assessment costs shall be provided to both the owner of the premises and the tenant.

f. Violations.

1. In addition to such other remedies as may be provided by law for violation of these regulations, the Authority may add such bacteria formulations to System servicing grease generating establishments regulated herein. The Authority may charge the cost thereof as an additional sewer use charge to the person or entity responsible for payment of sewer bills. In all events, the owner of the premises shall be ultimately responsible for any such charges.
2. In the event of any violation of this regulation or of any improper unauthorized use of any portion of the sewer system, then the owner and/or tenant shall in the discretion of the Executive Director be penalized a maximum of One Hundred and 00/100 (\$100.00) Dollars for each violation or improper unauthorized use.

Each day in which a violation or improper use occurs, shall be deemed a separate offense. For purposes of this regulation, two (2) test readings showing more than 100 parts per million by weight of fats, oils or grease within a calendar month shall be deemed to be presumptive evidence of a violation occurring in each day of that calendar month. In all events the owner of the premises shall bear ultimate responsibility for any such penalties.

3. In the event the Authority determines through testing that there has been a violation of these regulations, the Authority shall provide notice to the Owner of the premises and to the Tenant (if different from Owner of premises) of the details of the test results.
 4. All penalties are due and payable within thirty (30) days from the date that the Owner is notified in writing of the violations charged and the penalty to be imposed. In the event that any person aggrieved by the imposition of such penalty wishes to contest the violation or the penalty imposed, the person so aggrieved must file with the Authority a written notice that the violation or the penalty is being contested within thirty (30) days from the date of the notice of the penalty. The Authority shall thereafter schedule a hearing at which time the Executive Director or his/her designee, as well as the person contesting the violation or penalty or his/her attorney, may present evidence regarding the matter in dispute. If after the hearing, the Authority determines there is a penalty due and payable, it shall be paid within thirty (30) days after the aggrieved party receives written notice of the decision of the Authority. In the event the penalty is not paid as required under these rules, then the Authority in its discretion may take all actions available to it for the non-payment of sewer charges as provided in N.J.S.A. 40:14B-1 et seq. For purposes of these regulations, the Owner shall be responsible for the actions of any tenant using the sewer system.
 5. The penalties imposed in this section shall be cumulative to the penalties described in other sections of these Rules and Regulations and to other remedies afforded to the Authority by statute.
- g. Cost of Sampling.
- The cost of sampling and analyses shall be borne by the grease generating establishment. The owner of the premises is ultimately responsible for any cost charged to a tenant.
- h. Minimum Size.

All new grease traps to be installed in either new or existing grease generating establishments must be at least 100 lbs. minimum in size.

i. Significant Grease Generation.

Where any facility is termed a significant grease generating structure by the Authority, the applicant will be required to install a 1,000 gallon exterior grease trap. This includes but is not limited to all Chinese and Italian restaurants, cafeterias, and institutional kitchens.

j. Waivers.

The Authority may in its discretion waive or defer the requirements of this section if the grease generating establishment proves to the satisfaction of the Authority that it will not exceed the 100 ppm limit.

k. Definitions.

Definitions of terms as used in this section of the regulations shall have the following meanings:

Grease: Grease is defined to include the accumulation of oils, fats, cellulose, starch, proteins, wax, or grease, whether emulsified or not, in the Sewer System of the Authority. These are substances which may solidify or become viscous at temperatures between thirty-two (32) degrees Fahrenheit and one hundred fifty (150) degrees Fahrenheit (0 degrees - 65 degrees Celsius).

Grease Generating Establishments: Grease generating establishments shall mean all retail food establishments, catering establishments, commercial food preparation facilities, meat processing facilities, and other establishments that may be capable of accumulating and discharging grease into the Sewer System.

Owner: Owner shall mean individual, person, firm, company, association, society, corporation, or group upon whose property the building or structure is located or will be constructed.

l. Grease Monitoring Pit Detail.

GREASE MONITORING PIT DETAIL

N.T.S.

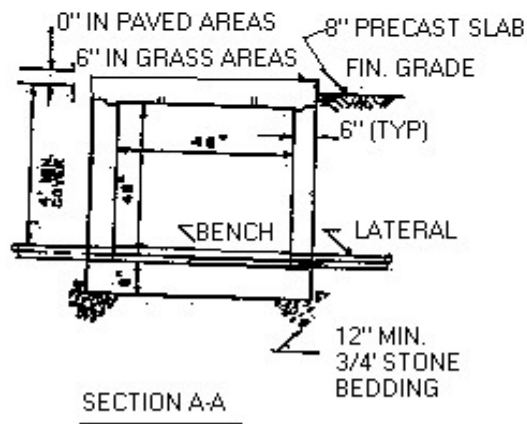
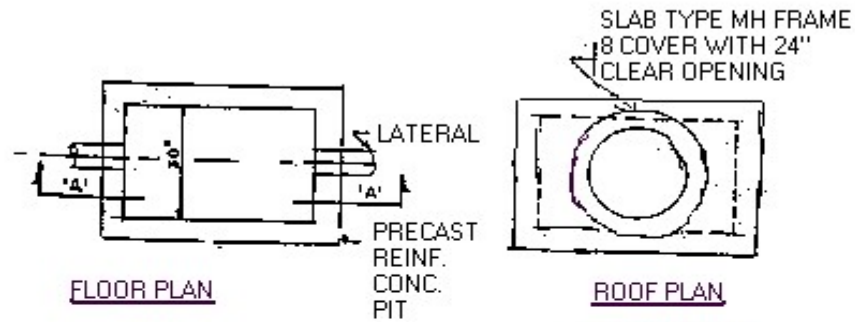

SPECIFICATIONS:

1. Concrete shall be designed to obtain a strength of 4,000 PSI in 28 days.
2. Reinforcing steel shall have a yield strength of 60,000 PSI.
3. The inlet shall be designed to meet the requirements of ASTM Spec. C-193.
4. Box shall be designed to carry H20 loadings when located in vehicle traffic area.

For Non H-20 Loading Area.

FOR NON H-20 LOADING AREA

(If applicant requires H-20 loading type or non H-20, a submittal to the MTMUA is required for approval)

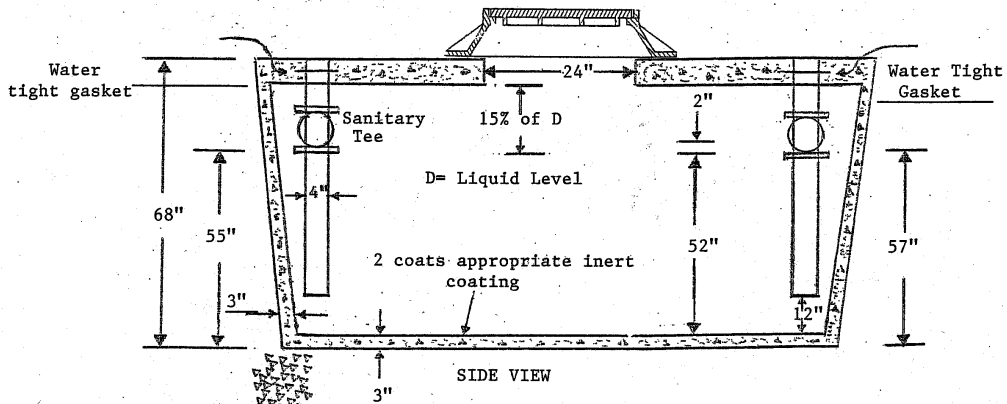
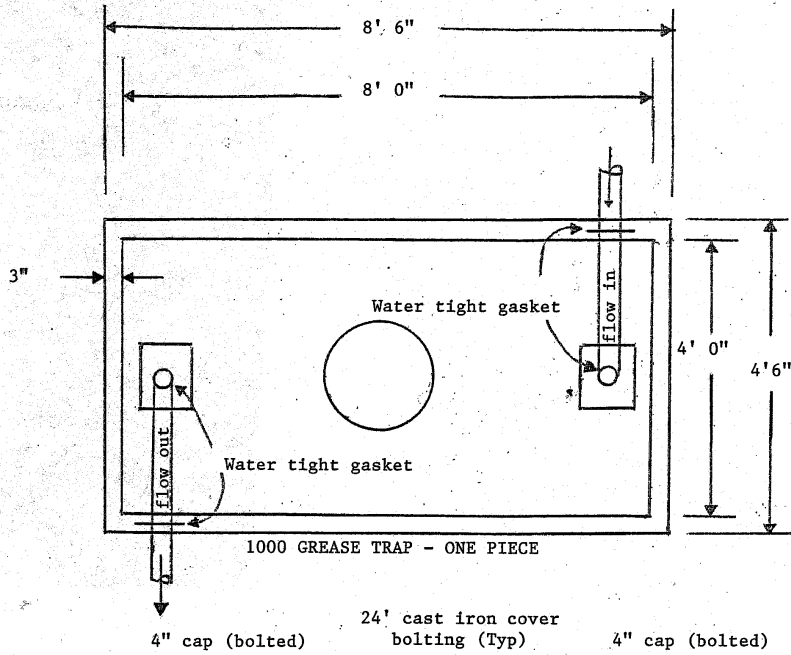

12" of 3/4" clean crushed blue stone

TANK IS 4000 PSI CONCRETE - STEEL REINFORCED
 CONCRETE CONFORMS TO ACI 318-16-4.5.1
 AND 318-16-4.5.2

S:11 USE OF SEWERAGE SYSTEM.

S:11-1 Use of Sewer by Authority.

During construction and before final acceptance, the Authority shall have the right to use any portion of the system completed without waiving their right to order correction of any defects.

S:11-2 Unauthorized Use of System.

- a. Use of the system for the discharge of sump pumps, or drainage from cellar drains, leaders, downspouts, drainage tile, developers cellar pits or pumping out septic tanks is strictly prohibited.
- b. Similarly, discharge of any non-approved commercial or industrial flow into the system is strictly prohibited.

S:12 COMPLIANCE WITH RULES AND REGULATIONS.

S:12-1 General.

- a. The Applicant shall comply with all of the Rules and Regulations as set forth herein. Failure to do so will result in a stop work directive by the Authority.
- b. The Applicant shall exercise all construction constraints needed to conform to the New Jersey Department of Environmental Protection Regulations.

S:12-2 Noncompliance.

- a. The Authority reserves the right to refuse to any applicant the privilege of connecting to the Authority's system, or to compel discontinuance of use of a sewer, or to compel the pretreatment of industrial wastes at any time, in order to prevent discharge into the sewerage system of wastes deemed to be harmful to the sewerage system, treatment process or operating personnel.
- b. If any person or industry shall fail or refuse, upon receipt of written notice from the Authority, to remedy any unsatisfactory condition relating to sewage discharge within a period of 24 hours of receipt of said notice, the Authority shall have the right to disconnect all service to said person or industry until such time as all violations have been corrected to the

satisfaction of the Authority. Violators will be charged for all costs incurred in emergency correction of the unsatisfactory condition and for all Authority expenses incurred.

S:13 PLANNED DEVELOPMENT PROCEDURE.

S:13-1 Procedure; Application.

- a. GDP applicants that seek to pursue this planned development procedure shall submit an application to the M.T.M.U.A. at least fourteen (14) days prior to the next regularly scheduled agenda meeting of the M.T.M.U.A.. Said application shall consist of the following:
 1. A completed "Sewer Service Preliminary Application" as set forth by the M.T.M.U.A. in these Rules and Regulations.
 2. A copy of the Monroe Township Planning Board resolution approving the General Development Plan ("GDP") application of the GDP applicant covering a tract of a minimum of 400 acres.
 3. A copy of the Planning Board resolution approving the first phase final major subdivision or final site plan application of the GDP applicant in connection with the planned development.
 4. A statement from the GDP applicant that it intends to develop the tract as a single entity.
- b. Sewer Capacities.
 1. Notwithstanding anything in Section S:4 or any other Section of the Rules and Regulations to the contrary, other than as set forth in Section S:12, approval of the application shall be deemed final approval of the vesting of the requested amount of sewer capacity as set forth in the Engineer's Report submitted by the GDP applicant as part of the Sewer Service Preliminary Application required by the M.T.M.U.A.'s Rules and Regulations. Said sewer capacity allocation shall not exceed the actual sewer capacity required or 200,000 GPD, whichever is less. Furthermore, any future applications for revisions or amendments to the initial approved Planned Development Preliminary Application shall be subject to review and approval by the M.T.M.U.A.. Any such revised or amended application shall not reduce the vested allocation previously obtained, provided however, that if said revision or amendment causes the actual sewer allocation required by the applicant to be less than that previously vested, then the application shall be revised to that lesser amount. The

GDP applicant will submit for preliminary, tentative and final approval of the specifications and plans for the utilization of said allocation in accordance with the Rules and Regulations in connection with each phase of its planned development.

2. In the event that the actual amount of sewer capacity for the planned development as set forth in the Engineer's Report exceeds 200,000 GPD, the GDP applicant may reapply for vesting of the requested amount of sewer capacity once fifty (50%) percent of its allocation has been used. Consistent with these Rules and Regulations, said sewer capacity allocation shall not exceed the actual sewer capacity that is still required or 200,000 GPD, whichever is less.

S:13-2 Payment Schedule.

- a. The vested sewer capacity shall be purchased on the following terms:

Within thirty (30) days of M.T.M.U.A. approval of the GDP applicant's application pursuant to this paragraph, the GDP applicant shall deposit with the M.T.M.U.A. the connection fee charge attributable to 5% of the applicant's vested capacity and the connection fees attributable to 10 equivalent dwelling units. The connection fees deposited, attributable to 5% of the applicant's vested capacity, shall be allocated to the last capacity to be utilized by the GDP applicant in the planned development.

The remaining connection fee charges attributable to each specific project of the planned development shall be paid by the GDP applicant to the M.T.M.U.A. in accordance with these Rules and Regulations.

Payment of connection fee charges by a GDP applicant shall be at the M.T.M.U.A. adopted and approved rate in effect at the time payment of the connection fee charge is made by a GDP applicant.

S:13-3 Forfeiture of Capacity.

The reservation of capacity to a GDP applicant pursuant to this Section S:13 shall remain in full force and effect so long as it is not forfeited pursuant to this section. A GDP shall forfeit his/her vested capacity, if during any three-year period, he has not utilized an average of five (5%) percent per year of the capacity reserved for the GDP applicant pursuant to This Section. In the event of a forfeiture, the M.T.M.U.A. shall immediately refund to the GDP applicant any connection fees paid by the GDP applicant which have not actually been utilized prior to the date of forfeiture.

S:14 REIMBURSEMENT REGULATIONS.

The Authority has determined that it is totally impractical to continue to calculate reimbursement on the basis of certified costs after construction. Subsequent developers' projects were being delayed waiting for certified costs from original developers, and the process has become unmanageable, hence these revised reimbursement regulations.

S:14-1 Definitions.

Developer. See S:2 Definitions of the MTMUA Rules & Regulations

Original Developer. Any developer or owner of a vacant lot who installs a sewer improvement pursuant to these Rules and Regulations to be owned by the Authority which improvement is capable of being utilized by other developers.

Subsequent Developer. Any developer or owner of a vacant lot who utilizes a sewer improvement installed by an original developer. Once a subsequent developer has paid the reimbursement amount chargeable to it pursuant to these Rules and Regulations, the subsequent developer will in turn be eligible for reimbursement from other subsequent developers.

Unit Price Matrix. A schedule of standardized unit prices for various elements of sewer construction to be used in calculating reimbursable amounts. This matrix will be revised by the Authority from time to time to keep pace with price changes. See Appendix A.

S:14-2 Developers Eligible for Reimbursement.

A Developer who is required by the Authority to make certain regional or sub-regional improvements may enter into a reimbursement agreement with the Authority by requesting same in writing. Such an agreement shall indicate that the Authority shall collect from each and every subsequent Developer a share of the cost of the improvements. These amounts will then be transferred to the original Developer or subsequent Developers who have paid reimbursement pursuant to these rules and regulations. These reimbursement agreements may provide for costs associated with gravity mains, force mains, pumping stations, sewage treatment facilities, etc. Any such agreements shall be subject to the following:

- a. The decision to enter into a reimbursement agreement shall be within the full discretion of the Commissioners of the MTMUA made only pursuant to a written request from the developer. Reimbursement agreements shall only be entered into when the proposed sewer improvements are in the best interests of the Authority as determined by the Authority Board of

Commissioners, such as when a regional approach is required or desirable.

- b. The amount which the Authority shall be required to collect from each and every subsequent Developer who is tributary to the constructed regional improvement shall be based upon the anticipated percentage of units that said Developer shall require and shall be calculated in accordance with S:14-3.

S:14-3 Amount of Reimbursement.

- a. The amount of the reimbursement shall be calculated as follows:

$$\frac{A}{B} \times C = \text{reimbursement amount}$$

Where:

A = The total number of Equivalent Dwelling Units (EDU's) for the subsequent Developer's entire project. An EDU shall be determined annually by the Authority as required by NJSA 40:14B-22.

B = The sum of all the EDU's of any and all developers including the EDU's reserved for the subsequent developer currently being required to reimburse, the total amount of which will be expressed in EDU's, as determined by the Authority Engineer.

C = Cost of the project eligible for reimbursement based on a unit price schedule as determined by the Authority Engineer to be reviewed and updated periodically.

- b. Example 1 - Developer 1 constructs a sewer system for his 1,000 unit development at cost determined by the Authority Engineer of \$3,000,000. After the project is complete, Developer 2 applies for approval of a project of 500 EDU's which utilizes all of the facilities which comprised the \$3,000,000 cost. Developer 2 must reimburse Developer 1 for \$1,000,000, calculated as follows:

A = Developer 2's total # of EDU's = 500 EDU's

B = Developer's 1&2 combined total # of EDU's=1,500 EDU's

C = \$3,000,000

(500 divided by 1,500) X \$3,000,000 (1's project cost) = \$1,000,000

If developer #2 had used only half of the facilities comprising the \$3,000,000 cost, then "C" would have been \$1,500,000 in the formula above, and the reimbursement would have been $(500/1,500) \times \$1,000,000 = \$500,000$.

- c. Example 2 - The facts are the same as in example 1 except that after Developer 2 finishes its project, Developer 3 seeks approval of a separate project with a capacity requirement also of 400 EDU's, which utilizes all the facilities comprising the total \$3,000,000 costs. Developer 3 would be required to reimburse Developers 1 and 2 in the amount of \$631,578.98, calculated as follows:

A = Developer 3's total # of EDU's = 400 EDU's

B = Developer 1 & 2 & 3's combined total # of EDU's = 1,900 EDU's

C = \$3,000,000

$400 \text{ divided by } 1,900 \times \$3,000,000 \text{ (1's project cost)} = \$631,578.98$

This reimbursement would be split between developers 1 and 2 as follows:

$\text{Developer 1} = \$631,578.95 \times \frac{(1000 \text{ EDU's})}{(1000 + 500 \text{ EDU's})} = \$421,052.59$

$\text{Developer 2} = \$631,578.95 \times \frac{(500 \text{ EDU's})}{(1000 + 500 \text{ EDU's})} = \$210,526.29$

S:14-4 Reimbursement Collection

The amounts to be collected from each subsequent Developer shall be collected within 60 days of the Final Approval. Final Approval will be subject to reimbursement within 60 days. Approval will become null and void if the reimbursement amount is not paid within the 60 day time period. Subsequent developers will not be allowed to connect to existing lines until the reimbursement has been paid.

S:14-5 Allocation of Reimbursement Amounts.

Any amount reimbursed pursuant to these regulations shall be allocated to prior developers in proportion to their dollar outlay of the cost.

The Authority shall be entitled to withhold from any reimbursement payments received, prior to remitting the same to the Developer, an amount equal to its administrative costs associated with the implementation of this Agreement. Such costs shall be calculated based upon the hourly compensation paid to the employee(s) or consultant(s) involved, including overhead costs.

S:14-6 Costs Eligible for Reimbursement.

The cost of a project eligible for reimbursement shall be based upon the Authority Engineer's approved estimate of project cost based upon the unit price matrix attached hereto as Appendix A. Eligible costs include construction costs plus "soft" costs. Soft costs include construction design, survey work, review and inspection fees, easement acquisition, permit fees, bonds payable to the Authority and any other costs determined by the Authority to be directly related to the construction of the project. These soft costs will be added to the construction costs as 40% of the construction costs. (See Appendix B to see how the 40% was derived.)

S:14-7 Terms and Conditions of Reimbursement.

- a. Upon written request from a developer, the Authority may enter into an agreement with each developer entitled to reimbursement at the time of final approval covering, among other things, any fees to the Authority to reimburse for administrative time in handling the reimbursement and any other matters agreed to by the developer and the Authority. Among the factors to be taken into consideration in negotiating such agreement may include:
 1. The size of the development.
 2. The estimated time to complete the development.
 3. The amount of improvements to be constructed by the developer.
 4. The likelihood that the facilities may be utilized by other developers.
 5. The dollar value of the improvements.
 6. The number of EDU's utilized by the developer.
 7. The term of all reimbursement agreements shall be no more than ten years.

8. Any governmental entity, or an existing residence or business on a septic system shall be exempt from any and all reimbursement terms and conditions. Vacant lots are not exempt.

S:14-8 Indemnification.

The Authority will use its best efforts in accordance with existing law to collect the reimbursement amounts from subsequent parties but, in no event, shall be liable to the Developer for failure to collect.

S:14-9 Assignability

This agreement shall not be assignable by the Developer without the prior written consent of the Authority, which will not be unreasonably withheld or delayed and which consent shall be conditioned upon the posting of proper Performance Guarantees, if any, and the execution of such documents as deemed appropriate by the Authority attorney to assure that the assignee shall be entitled to all the obligations and benefits to Developer under this agreement.

The Authority will include indemnification provisions in the reimbursement agreements that require the Developer who enters said agreement to hold harmless, indemnify and defend the Authority in the event that the reimbursement agreement is subjected to legal challenge. Said agreements may also provide that any legal defense that the Developer may provide to the Authority shall be under the direct supervision and control of the Authority attorney and that any settlement decisions with respect to any such litigation shall be within the full discretion of the Authority.

S:14-10 Legal Challenge

Any Developer wishing to enter a reimbursement agreement may be required by the Authority to provide an appropriate Bond or Letter of Credit in the form and amounts required by the Authority attorney in order to protect the Authority in the event that the reimbursement agreement is subject to legal challenge.

S:15 FORMS.*

- a. Preliminary Sewer Application, See Form S1.
- b. Tentative Sewer Application, See Form S2.

- c. Final Sewer Application, See Form S3.
- d. Application for Extension of Approval for Sewer, See Form S4.
- e. Approval to Obtain Building Permit for Sewer, See Form S5.
- f. Individual Sewer Connection Application, See Form S6.
- g. Approval of Water and/or Sewer Facilities for C.O., See Form S7.
- h. Deed of Easement, See Form S8.

*Editor's Note: Forms may be found at the end of this section.

S:16 FILING, REVIEW, AND INSPECTION FEES

- a. Where mains are to be constructed by anyone other than the Authority, the applicant shall make application and pay fees on an hourly basis to draw down against the deposit as listed below:
 - 1. Application for Review of Preliminary Plans:
 - Minor.....\$250.00
 - Major - Deposit..... \$ 7.25 per unit
\$450.00 minimum
 - 2. Application for Tentative Approval
 - Review Fee.....1 1/2% of est. construction cost
 - 3. Application for Final Approval:
 - Review Fee.....1 1/2% of est. construction cost
 - Inspection Fee.....5% of est. construction cost
- b. Grant Restriction Waiver. Request for wetlands grant restriction or waiver or USEPA Mapping Revision processing must be made by the owner of the property. A \$363.30 processing fee made payable to the Monroe Township Municipal Utilities Authority must accompany the request.
- c. Extensions and Revisions. Applications for extensions of approval with no changes must be accompanied by a review fee deposit of \$290.00. Application for revisions after submittal and initial review must be accompanied by a review fee deposit of \$450.00.
- d. Depletion of Deposit Prior to Completions. If the deposit is depleted before completion of review or inspection, the applicant shall deposit an additional amount to complete the review or inspection as estimated by the Authority Engineer within five (5) days of notification or all review and inspection will cease at the end of five (5) days after notification. Any

deposit monies not used will be returned to the applicant within two (2) months after acceptance of the maintenance bond for the project.

- e. Calculation of Fees. The amount charged by the Authority shall be calculated by the Authority's budget for the coming fiscal year, and shall be based on the hourly salary cost to the Authority, the cost of fringe benefits payable to said individual and the cost of the overhead of the Authority allocable to that employee.

*Applicant is required to submit IRS Form W-9 (request for taxpayer identification number and certification) with filing, review and inspection fees.

(Revised 6-19-03)

FORM S1 PRELIMINARY SEWER APPLICATION, SEE SEPARATE FILE

FORM S2 TENTATIVE SEWER APPLICATION, SEE SEPARATE FILE

FORM S3 FINAL SEWER APPLICATION, SEE SEPARATE FILE

FORM S4 EXTENSION OF APPROVAL FOR SEWER, SEE SEPARATE FILE

FORM S5 APPROVAL TO OBTAIN BUILDING PERMIT, SEE SEPARATE FILE

FORM S6 INDIVIDUAL SEWER CONNECTION, SEE SEPARATE FILE

FORM S7 WATER/SEWER FACILITIES "C.O." APPROVAL APPLICATION, SEE SEPARATE FILE

FORM S8 DEED OF EASEMENT

Deed of Easement

This Deed, made on This _____ day of _____, _____,

BETWEEN _____, referred to as Grantor, whose address is _____,

AND THE MONROE TOWNSHIP MUNICIPAL UTILITIES AUTHORITY, a public body corporate and politic of the Township of Monroe, County of Middlesex and the State of New Jersey, with its principal office at 143 Union Valley Road, in the Township of Monroe, County of Middlesex and State of New Jersey, referred to as the Authority.

WITNESSETH, that the Grantor, in consideration of LESS THAN ONE HUNDRED AND NO/100 DOLLARS (LESS THAN \$100.00), the receipt of which is hereby acknowledged, does hereby grant and convey to the Authority, an Easement across the property in the Township of Monroe, County of Middlesex and State of New Jersey, being part of the premises known as Lot _____,

Block _____ on the Tax Map of Monroe Township, Middlesex County, New Jersey and more particularly described in Schedule A attached hereto.

The easement herein granted and conveyed by the Grantor to the Authority gives the Authority the right to construct, maintain, replace, or supplement its sewerage/water and appurtenant facilities on or under the surface of the said premises and to have free access to and across the said premises without need of notice, insofar as such right of access is necessary to the proper use of any right granted herein, on the condition that the Authority, after doing any work on the premises, shall restore the premises substantially to its original condition, to the extent possible.

With respect to the easement herein granted, the GRANTORS, their heirs and assigns, shall have the right to surface use of the said premises, but agree to be limited as follows:

Prepared by:

1. No obstruction or encumbrance, physical or otherwise, shall be placed in or about the said premises which will obstruct the Authority's purposes as expressed herein. This prohibition includes, but is not limited to, the planting of trees, placement of permanent structures, the storage of materials or the erection of fencing.

2. No fill, material, machinery, appliances, or similar objects may be placed on the said premises which will impose an additional loading in excess of one hundred pounds per square inch (100 lbs./sq. inch) without the prior written approval of the Authority.

3. Fencing may be erected, as approved by the Authority, provided the Grantor or his/her successor is responsible for all costs associated with removal and/or reinstallation of the fencing if and when it becomes necessary for the Authority to work within the easement.

THE GRANTOR promises that the Grantor has done no act to encumber the property. This promise is known as a "covenant as to Grantor's acts". (N.J.S.A. 46:4-6).

IN WITNESS WHEREOF, the said Grantor has hereunto set his/her hand and seal the day and the year first above written.

ATTEST:

BY:

STATE OF NEW JERSEY, COUNT OF

SS:

I certify that on _____, under oath, to my satisfaction, that This person (or if more than one, each person):

- (a) is named in and personally signed This Deed;
- (b) signed, sealed and delivered This Deed as his/her or her act and deed; and
- (c) made This Deed for less than \$100.00 plus other valuable consideration as the full and actual consideration paid or to be paid for the grant of easement.

FOR RECORDING RETURN TO:

MONROE TOWNSHIP MUNICIPAL UTILITIES AUTHORITY

143 UNION VALLEY ROAD

MONROE TOWNSHIP , NEW JERSEY 08831