

WOOD THAT WORKS

DAVE & MARJI ROY

TUMBLER



Large Rear Wheel

Metal Hook

Metal Hook

Small Wheel

Light Weight

Heavy Weight

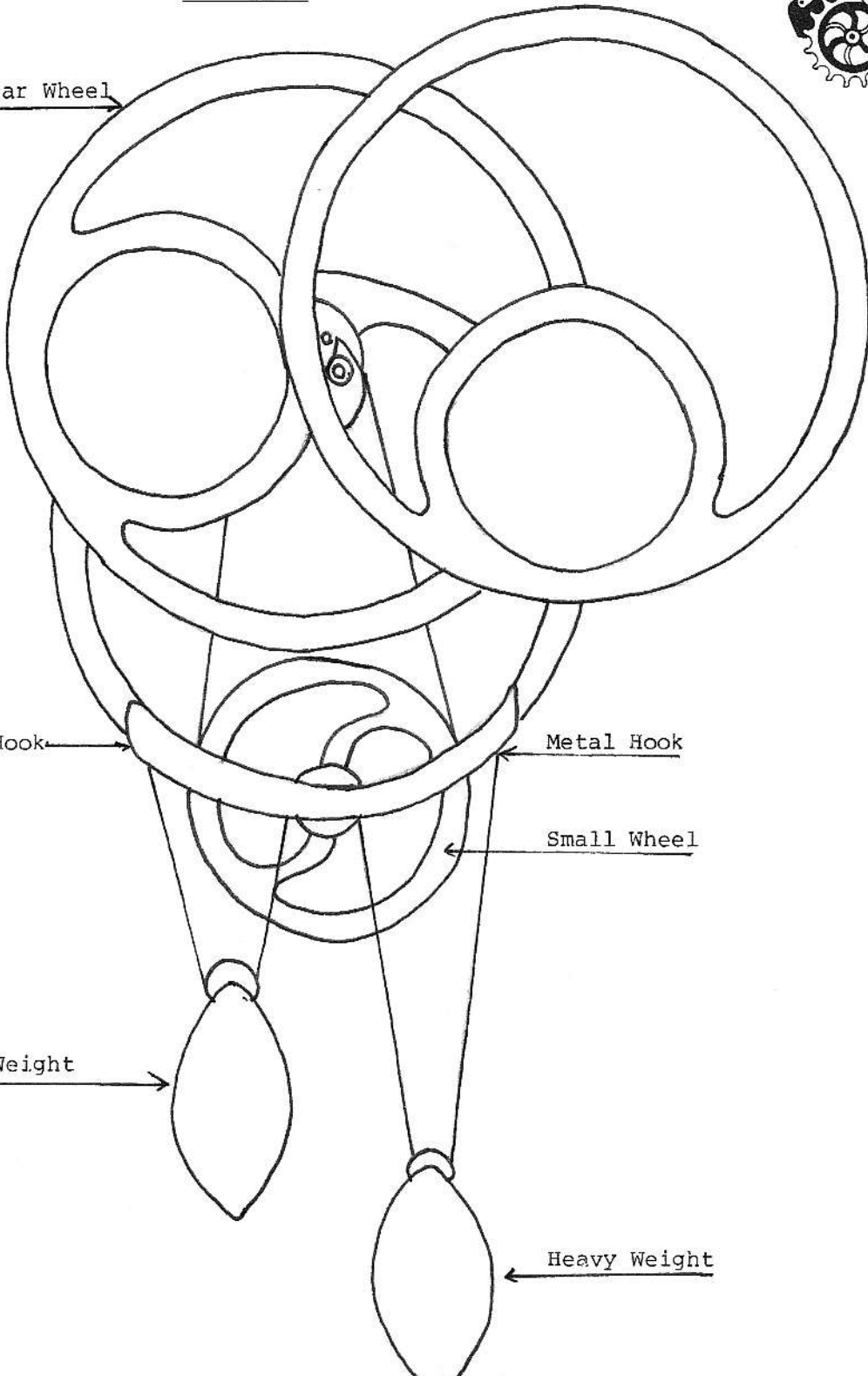

TUMBLER

Directions:

To Unpack:

1. Remove packing material and unscrew sculpture from packing backboard.
2. Carefully untape and remove the cardboard covers and shipping spacers. Be careful not to damage the parchment papers under the covers.

To Mount on Wall:

1. Hold the backboard/template in the desired location against the wall. Make sure the bottom edge is level.
2. Place a sharp instrument through the mounting screw holes marking their positions on the wall. The proper holes are labeled.
3. Drill pilot holes. If the wall is sheetrock or plaster use the plastic anchors.
4. Hang the sculpture up using 1½" round head brass screws.

To Suspend the Weights:

1. Place the two weights on the floor below the sculpture with the heavy weight on the right.
2. Tie a small loop in one end of the string provided.
3. Loop this string over the small metal hook on the dowel on the lower-right side of the sculpture.
4. Pass the other end of the string under the pulley on the heavy weight and up and over the pulley on the front of the small wheel.
5. Cut the end of the string about 12" below the bottom of the sculpture. Tie a loop in this end. Hold the the light weight and pass the string under its pulley and place the loop over the hook on the dowel on the lower-left side.

To Wind:

1. Slowly pull the left weight down until it reaches the floor.

To Start:

1. Push the large, rear circle one revolution in a clockwise direction.

Please save the shipping box and backboard to aid you when moving, storing or shipping your sculpture. The box can be collapsed for easy storage.