

# INTERPRETATION OF REAL PROPERTY DESCRIPTIONS



This page intentionally left blank

**FLORIDA ASSOCIATION OF CADASTRAL  
MAPPERS**

**In conjunction with**

**THE FLORIDA DEPARTMENT**

**OF REVENUE**

**Presents**

**FACM COURSE 3  
INTERPRETATION OF REAL PROPERTY  
DESCRIPTIONS**

**Objectives**

**Upon the successful completion of this course the student should:**

Know why we use the systems of describing land that we do;

Understand the different methods of describing real property;

Understand the terminology used in the various descriptions;

Be able to break down the different types of descriptions into their various parts to aid in plotting or computing same;

Understand the basics of resolving discrepancies among descriptions;

Have a rudimentary understanding of water boundaries and the effects both mankind and nature may have on same;

Plot different types of descriptions and begin map compilation in preparation for FACM Course 4; and

Know where to go for help if all else fails.

---

# Interpretation of Real Property Descriptions

---

## Table of Contents

Objectives .....	ii
INTRODUCTION.....	vi
<b>Day 1.....</b>	<b>1</b>
FUNDAMENTALS of DESCRIPTIONS .....	2
What is A Description?.....	2
What is a "Legal" Description? .....	2
Types of Descriptions .....	3
Projections & Florida State Plane Zones .....	8
Description Word Definitions .....	12
Description Phrase Definitions.....	17
Miscellaneous Description Information.....	20
Who Writes Descriptions? .....	23
Fundamentals of Descriptions - Quiz .....	25
METES AND BOUNDS DESCRIPTIONS .....	27
Original Concept .....	27
Requirements of a Metes and Bounds Description.....	28
Format of a Description .....	29
Reference Descriptions .....	32
How to Read a Metes and Bounds Description.....	33
Measurements of Distance .....	43
ENGINEERING SCALE.....	49
PROTRACTOR.....	54
BEARING & DISTANCES .....	60
LAND COMPASS .....	62
Metes and Bounds Descriptions - Quiz.....	69
<b>Day 2.....</b>	<b>72</b>
CURVES.....	73
Definitions.....	73
Circular Curve .....	74
Five Elements Necessary to Plot a Curve .....	75
Tangent curves .....	76
Compound Curve.....	76

# Interpretation of Real Property Descriptions

---

Reverse Curve .....	77
Spiral Curve .....	78
Concavity or Convexity .....	79
Radial Line .....	80
Non-tangent .....	80
Point of Cusp .....	80
Different Types of Curves and Parts of Curves .....	81
Abbreviations .....	82
MAPPING STUDY EXERCISES - CURVES .....	84
Curves - Quiz .....	86
Typical Curve .....	88
Curve Exercises .....	89
Curve Exercises - Homework .....	98
<b>Day 3 .....</b>	<b>100</b>
SUBDIVISION DESCRIPTIONS .....	101
History of Subdivision Descriptions .....	101
Check the Plat Perimeter Description to the plat drawing .....	102
Dedication .....	102
Basis of Bearing .....	103
F.S. 177.081 Dedication and Approval .....	103
Subdivision Examples .....	104
STRIP DESCRIPTIONS .....	112
What is a Strip Description? .....	112
Strip Description Examples .....	113
Subdivision & Strip Descriptions - Quiz .....	118
STATIONING .....	119
What is a Stationing? .....	119
Stationing Along Curves .....	121
Stationing - Quiz .....	127
Day 3 Homework: .....	129
Mapping in the Office of the Property Appraiser .....	130
General Information .....	130
Florida Statutes .....	150
Cadastral Mapping Guidelines .....	152

# Interpretation of Real Property Descriptions

---

Property Appraiser Mapping - Quiz .....	178
<b>Day 4.....</b>	<b>180</b>
RESOLVING PROBLEMS .....	181
Different Feet, Degrees, Curves and Elevations .....	181
Relationship between Descriptions and Surveys .....	183
Legal Aspects of Descriptions .....	185
Superiority of Calls .....	186
PRACTICAL ASSISTANCE.....	187
INTENT .....	191
SENIOR RIGHTS .....	191
WHEN ALL ELSE FAILS .....	192
Resolving Problems Quiz.....	193
DAY FOUR MAPPING EXERCISES.....	194
QUIZ ANSWERS .....	212
Day One – Fundamentals Quiz Answers .....	213
Day One - Metes & Bounds Quiz Answers .....	215
Day Two - Curves Quiz Answers .....	217
Day Three - Subdivision & Strip Quiz Answers .....	219
Day Three - Stationing Quiz Answers .....	220
Day Three - Property Appraiser Mapping - Quiz Answers.....	222
Day Four - Resolving Problems Quiz Answers.....	223
Day Two - Curve Mapping & Exercise Solutions.....	225
Day Two – Curve Homework Answers.....	236
Day 3 Stationing on Curves Homework Answers.....	238
Summary of Legal Descriptions .....	239
Perimeter Descriptions.....	239
Strip Descriptions .....	239
Area Descriptions .....	239
Other Descriptions.....	239
Example of Adjoiner Description.....	253
Example of Deflection Angles used in a Description.....	256
<b>Formulas.....</b>	<b>Error! Bookmark not defined.</b>

## FACM COURSE 3

### INTERPRETATION OF REAL PROPERTY DESCRIPTIONS

#### INTRODUCTION

Many books were used as references in the creation of this course. Books, such as *Writing Legal Descriptions* by Gordon H. Wattles, *Clark on Surveying and Boundaries* by Walter G. Robillard and Lane J. Bouman, Skelton's *The Legal Elements of Boundaries and Adjacent Properties* by Ray Hamilton Skelton and *Black's Law Dictionary with Pronunciations* contain material that will help you interpret descriptions. This course is **NOT** necessarily about teaching you how to write descriptions, only to interpret their meaning, but some basic instruction in writing descriptions for cadastral mapping purposes is discussed.

This course will begin with the basics of drawing a cadastral map using what was learned in FACM Courses 1 and 2 along with the instruction in this class. Therefore the student of this class should already know, prior to taking this course, the following:

- 1) What is a bearing within a description?
- 2) What an arc is and the basics on how one plots an arc; Curves will be covered at length in FACM Course 3;
- 3) What are angles and how to work with them,
- 4) What is a township, range, and section and how to determine the basic parts of a section (covered in FACM Course 2 – The Public Land Survey System);
- 5) How to search the public records and research the title of parcels;
- 6) What the Florida State Plane Coordinate System is and how to use coordinates to draw a parcel and calculate the bearing and distance of the sides of the parcel (covered in FACM Course 2);
- 7) The algebra and trigonometry involved to solve for angles and distances (covered in FACM Course 1 – Mathematics for the Cadastralist).

While we will briefly review some of the above items, the purpose of this course is to impart the methods one may use to interpret real property descriptions. If you do not have a good understanding of the items listed above, you will not be able to achieve the class objectives.

Of course the interpretation of descriptions sometimes involves the study of real estate law, including case law. This presentation will expound on various legal issues and interpretations of the rulings by the courts as we understand them but neither the author of this course nor the multiple sponsors are attorneys and you should not rely on what you see or hear as a substitute for competent legal advice from an attorney experienced in real property boundary law.

This page intentionally left blank



# Day 1

## **Fundamentals of Descriptions and Metes and Bounds Descriptions**

# Interpretation of Real Property Descriptions

---

## **FUNDAMENTALS of DESCRIPTIONS**

In this chapter we will define the word description, relate the various types of descriptions, and get into the details of the more commonly used words and phrases and discuss who writes descriptions.

### **What is A Description?**

Wattles say: “..A description of the outline of a certain area is the proper grouping of words which delineate one specific piece of land and which cannot apply to any other piece of land.”

According to *Black’s Law Dictionary* a description is: “A delineation or account of a particular subject by the recital of its characteristic accidents and qualities.” Later on under the same definition, the following is found: “That part of a conveyance, advertisement of sale, etc., which identifies the land or premises intended to be effected.”

*Webster’s Encyclopedic Unabridged Dictionary of the English Language* says a description is: “1. A statement, picture in words, or account that describes; ... 4. Geom. The act or process of describing a figure.”

Since Wattles’ definition relates to the perfect world and assumes that they are for land only, as does Blacks definition, we will use our own throughout the remainder of this text.

A description is:

**A phraseology and construction that conveys the shape and size, sometimes through extrinsic evidence, of a parcel on, below or above the surface of the earth.**

### **What is a "Legal" Description?**

What makes a description legal? According to Black’s Law Dictionary it is a description that is provided for in statutory law. Florida’s statutory law only speaks of lot and block (Chapter 177.021) and condominium parcels (Chapter 718.109). The Federal Code only speaks of sectional breakdown down to the quarter quarter (a 40 acre tract). **Also**, the inclusion of a description into an instrument of conveyance causes the description to become a legal description.

# Interpretation of Real Property Descriptions

---

## **177.021 Legal status of recorded plats. ---**

“The recording of any plats made in compliance with the provisions of this chapter shall serve to establish the identity of all lands shown on and being a part of such plats, and lands may thenceforth be conveyed by reference to such plat.”

## **718.109 Legal description of condominium parcels. ---**

“Following the recording of the declaration, a description of a condominium parcel by the number or other designation by which the unit is identified in the declaration, together with the recording data identifying the declaration, shall be a sufficient legal description for all purposes. The description includes all appurtenances to the unit concerned whether or not separately described including, but not limited to, the undivided share in the common elements appurtenant thereto.”

According to Gurdon H. Wattles in his book *Writing Legal Descriptions in Conjunction with Survey Boundary Control* on Page IX, third paragraph and Page 3.1, first paragraph, a **“legal” description is a description that “...must be able to withstand attack [Ed: litigation] under law.”**

## **Types of Descriptions**

Over the years mankind has created more and more complicated things and conditions for himself. Various different methods of describing a parcel have been created to serve these conditions. This section briefly discusses those different methods, provides examples of each and explains the pros and cons of each.

### **ADJOINER -**

Black’s Law Dictionary for the word “adjoining” says: “...touching or contiguous, as distinguished from lying near to or adjacent.” For adjoining owners it says: “Those persons who own land touching the subject land and who, as a result, have right of notice of proceedings concerning the subject real estate.

Wattles relates: “a boundary description stated totally by reference to other parcels already on record in the public repository.

Example:

“All that land bounded on the North by the Florida/Alabama and Georgia state line, on the East by the Atlantic Ocean, on the South by the Cross Florida Barge Canal and on the West by the Gulf of Mexico and the Perdido River. Said lands also being known as North Florida.”

# Interpretation of Real Property Descriptions

---

Pros and Cons:

Cons: It relies totally on the names of monuments that were common when the description was written, but may not be when the description is reviewed; it provides no means to relate the size of the parcel being described and no way to check the accuracy of the information in the description.

Pros: It is easy to write; no skills were necessary to write it; no skills are necessary to read it other than knowledge of the general area and it provides, in most cases, the on-site visible keys to determining its location.

*[See Appendix for example and sketch.](#)*

## **METES and BOUNDS -**

Black's Law Dictionary says: "The boundary lines of land, with their terminal points and angles. A way of describing land by listing the compass directions and distances of the boundaries..."

Wattles says: "...'metes' means bearings and distances and 'bounds' means and refers to monuments both physical or legal."

In general, it describes a parcel by providing the direction and distance of each course around a figure and relates the monuments that control that figure. Now it is used for just about any description that contains a direction and/or a distance.

Example:

Begin at the Northwest Corner of Section 14, Township 29 South, Range 24 East, Polk County, Florida, thence N.45°W. a distance of 100.00 feet; thence N.45°E. a distance of 100.00 feet; thence S.45°E. a distance of 100.00 feet; thence S.45°W. a distance of 100.00 to the Point of Beginning.

Pros and Cons:

Cons: It is difficult to write because it requires some skill to write (both legal and mathematical); it requires some skill to read it correctly; it is finite and it does not relate in the description itself local items by which a person may understand the location of the parcel being described by physically describing the bounds on the site.

Pros: It is definitive - not much question of what is being described; the size of the parcel can be determined without reference to another object and it can be mathematically checked to determine its accuracy.

# Interpretation of Real Property Descriptions

---

## **SECTIONAL -**

A sectional description method solely utilizes the federal and/or state government subdivision of the public domain into townships, ranges and sections or other such similar grid based systems.

Example:

The Northwest Quarter of Northwest Quarter of Section 10, Township 28 South, Range 23 East, Polk County, Florida.

Pros and Cons:

Pro: This system provides a simplified method of locating the parcel involved; one can describe most any size parcel with few words; a parcel can be located with certainty and it is unique.

Cons: Retracing the original government surveys is often difficult; it is unsuitable for describing irregularly shaped land parcels; land partitioning in areas of rugged terrain or waterways is not convenient because it disregards natural features.

## **SUBDIVISION (also known as Lot and Block) -**

A subdivision description uses solely the name of the parcels as shown on a recorded document that subdivided a larger parcel in accordance with state law.

Example:

Lot 32 of Hillside Heights Subdivision, as recorded in Plat Book 115, Pages 43 and 44, of the Public Records of Polk County, Florida.

Pros and Cons:

Pros: One can describe most any size or shape parcel with few words; a parcel can be located with certainty; and it is unique.

Cons: requires a survey prior to description preparation; a long and expensive trip through the morass of government agencies and its size cannot be determined without reference to the recorded plat.

# Interpretation of Real Property Descriptions

---

## **STRIP -**

A strip description recites a particular line by metes and bounds together with the widths of the parcel being included on one or both sides that **does not** return to the point of beginning.

Example:

A strip of land 20 feet wide in Section 13, Township 28 South, Range 23 East, Polk County, Florida, lying 10 feet on each side of the following specifically described centerline:

From the Northwest Corner of said Section 13, bear N.45°W. a distance of 100.00 feet to the terminus of said centerline.

Pros and Cons:

Pros: One can describe most any narrow but long parcel that has a fixed (even varying) width with few words and the size of the parcel can be determined without reference to any other item.

Cons: requires a survey prior to description preparation; has no means to mathematically check its perimeter and leaves doubt as to what parcel is included if the beginning or its closing lines are not at right angles to the described line and the author didn't tell you what to do in each case; and leaves doubt whether or not the width should be extended past the terminating point.

## **COORDINATE -**

A description of land based on coordinates eliminates many disadvantages found in both the metes and bounds and the rectangular survey systems.

Most surveys of small areas are based on the assumption that the earth's surface is a plane (a flat surface), even though the true relationships of points to each other can only accurately be expressed in terms of spherical coordinates (latitude and longitude). To compute areas, distances, and positions using spherical mathematics is difficult and complicated. Because many surveyors were unable to use this method of referencing points, a system of listing geodetic stations, using plane rectangular coordinates was needed. The United States Coast and Geodetic Survey (nka: National Geodetic Survey of the National Ocean Survey) fulfilled this need by developing a *state plane coordinate system* for each state.

## Interpretation of Real Property Descriptions

---

Such a system provides a common *datum* for referencing the horizontal control of all surveys in a large area. It eliminates individual surveys based on assumed coordinates that are not related to those used in other work.

Because the earth's surface is curved and irregular, it was necessary to develop a *projection* to cover the area that would provide a plane surface for surveyors and mappers. A rectangular grid can be superimposed on the developed plane surface and the positions of points in the plane located by means of X and Y coordinates.

Pros and Cons:

Pros: Coordinates can be used to locate any point and are therefore used more and more by surveyors and mappers. They provide a permanent reference to the earth that is not dependent on man-made markers, natural or cultural features. They can also provide easily relocated property lines.

Cons: They were not used that much by the private surveyors due to the costly and time consuming control network and mathematical calculations for the older means of determining survey quality coordinates.

## Projections & Florida State Plane Zones

Two projections are used in the state plane coordinate systems: the *Lambert conformal conic* projection and the *Transverse Mercator* projection.

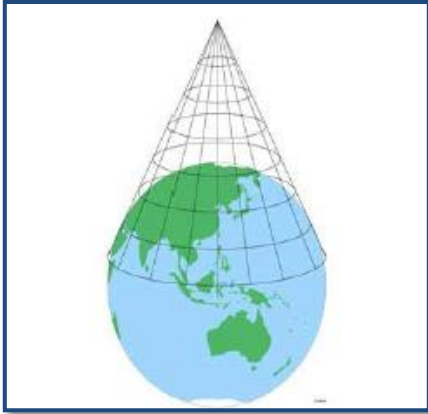

### Lambert Conformal Conic Map Projection

Lambert projects an imaginary cone to cover the area of interest and has greater east - west dimensions than north - south dimensions.

### Transverse Mercator Map Projection

The Transverse Mercator projection is based on an imaginary cylinder covering the area of interest. This projection is best for areas that lie in a north - south direction.

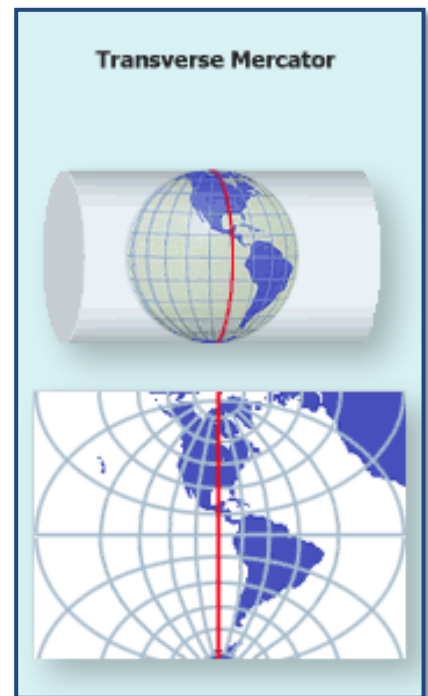

Florida utilizes both projections, the *Lambert conformal conic* projection for the “panhandle” and the *Transverse Mercator* projection for the remainder of the state.



# Interpretation of Real Property Descriptions

After the systems have been established, they provide the same information and are used in the same way. A rectangular grid is developed that covers an entire state or a portion of a state, called a *zone*. The grid actually covers an area larger than the zone in order to provide a zero X and Y position outside the zone. This zero is located south and west so that only positive numbers are used. The *X value is used to show the number of units east of zero* while the *Y is used to show the number of units north of zero*. If a state has two or more zones, there is enough overlap that no county will fail to be entirely covered by at least one zone.

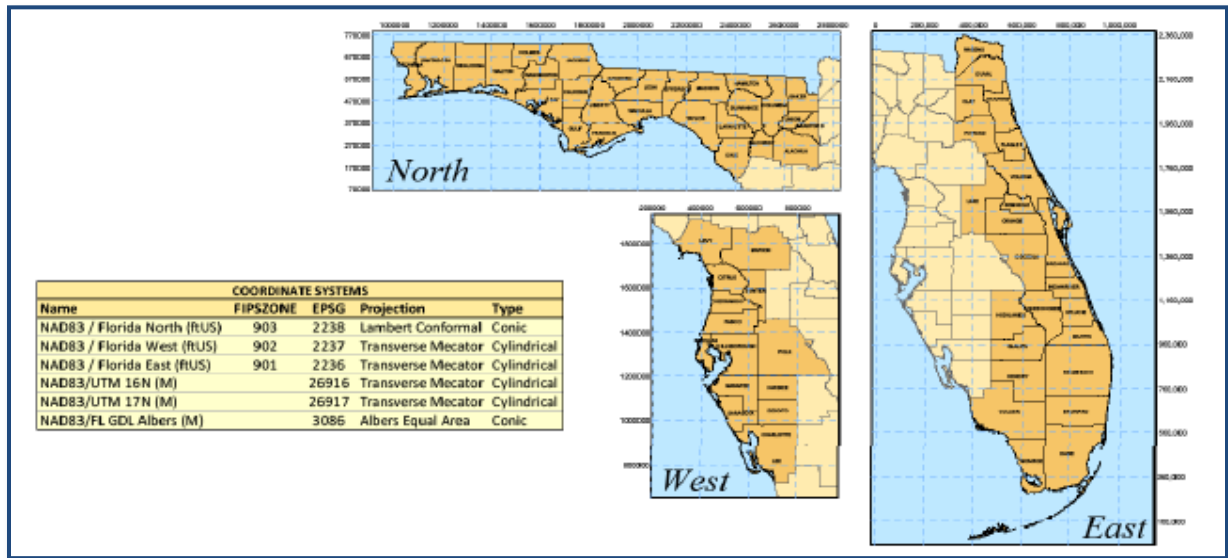

## Florida State Plane Zone Map

Most small states, or narrow and elongated states (such as Tennessee), have only one zone. Larger states have two or three zones, and some have more. For example, Texas has five zones and California has seven. Florida has three state plane coordinate zones. The reason for the multiple zones is to keep the maximum error (difference between the actual ground distance and the grid distance) within a specific range.

# Interpretation of Real Property Descriptions

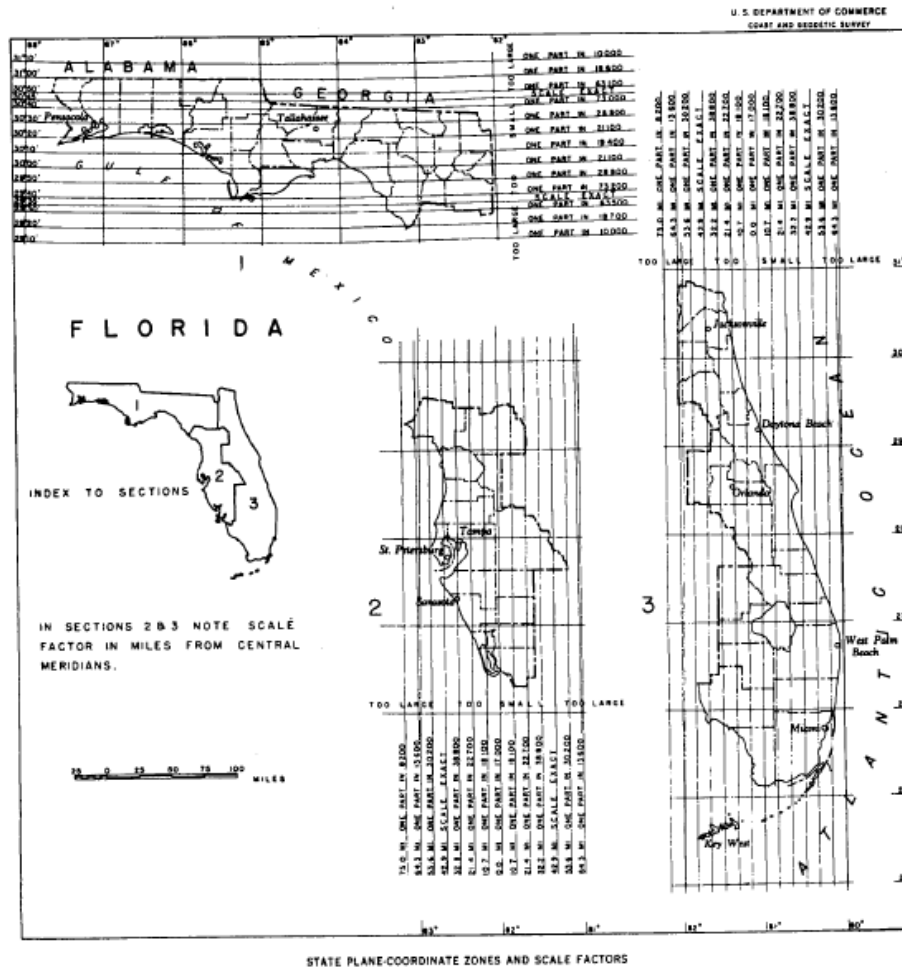

From the state plane coordinate creation for Florida till 1971, there was no official Florida law acknowledging its existence or allowing its use in descriptions, etc. As a part of the 1971 Plat Law created and passed by the surveyor and mappers, Florida officially accepted its existence.

“[177.031 Definitions](#).”--As used in this chapter:

“(19) "State plane coordinates" means the system of plane coordinates which has been established by the National Ocean Service for defining and stating the positions or locations of points on the surface of the earth within the state and shall hereinafter be known and designated as the "Florida State Plane Coordinate System." For the purpose of the use of this system, the zones established by the National Ocean Service in NOAA Manual NOS NGS 5, State Plane Coordinate System of 1983, shall be used, and the appropriate projection and zone designation shall be indicated and included in any description using the Florida State Plane Coordinate System.

## Interpretation of Real Property Descriptions

---

At that point it became possible to write a description for recordation in Florida that used solely state plane coordinates.

The official description of the State of Florida, as worded in the Constitution of the State of Florida under [Article II, Section 1](#) and shown below as an example, uses coordinates exclusively for certain calls. While this description uses geographic coordinates (latitude and longitude), they are still coordinates. In fact the zero points for the x and y coordinates of the Florida Coordinate System are a specific geographic coordinate.

### **Example:**

Begin at the mouth of the Perdido River, which for the purposes of this description is defined as the point where latitude 30°16'53" north and longitude 87°31'06" west intersect; thence to the point where latitude 30°17'02" north and longitude 87°31'06" west intersect; thence to the point where latitude 30°18'00" north and longitude 87°27'08" west intersect; thence to the point where the center line of the Intracoastal Canal (as the same existed on June 12, 1953) and longitude 87°27'00" west intersect; the same being in the middle of the Perdido River; thence up the middle of the Perdido River to the point where it intersects the south boundary of the State of Alabama, being also the point of intersection of the middle of the Perdido River with latitude 31°00'00" north; thence east, along the south boundary line of the State of Alabama, the same being latitude 31°00'00" north to the middle of the Chattahoochee River; thence down the middle of said river to its confluence with the Flint River; thence in a straight line to the head of the St. Marys River; thence down the middle of said river to the Atlantic Ocean; thence due east to the edge of the Gulf Stream or a distance of three geographic miles whichever is the greater distance; thence in a southerly direction along the edge of the Gulf Stream or along a line three geographic miles from the Atlantic coastline and three leagues distant from the Gulf of Mexico coastline, whichever is greater, to and through the Straits of Florida and westerly, including the Florida reefs, to a point due south of and three leagues from the southernmost point of the Marquesas Keys; thence westerly along a straight line to a point due south of and three leagues from Loggerhead Key, the westernmost of the Dry Tortugas Islands; thence westerly, northerly and easterly along the arc of a curve three leagues distant from Loggerhead Key to a point due north of Loggerhead Key; thence northeast along a straight line to a point three leagues from the coastline of Florida; thence northerly and westerly three leagues distant from the coastline to a point west of the mouth of the Perdido River three leagues from the coastline as measured on a line bearing south 0°01'00" west from the point of beginning; thence northerly along said line to the point of beginning. The State of Florida shall also include any additional territory within the United States adjacent to the Peninsula of Florida lying south of the St. Mary's River, east of the Perdido River, and south of the States of Alabama and Georgia.

(2) The coastal boundaries may be extended by statute to the limits permitted by the laws of the United States or international law.

# Interpretation of Real Property Descriptions

---

## COMBINATION -

A combination of one or more of the above types of descriptions. Quite often the adjoining description, using calls to adjoining titles, and the metes and bounds description, which contains bearings and distances was used. The Combination description also is the most common type today where the lands have not been subdivided sufficiently to easily describe the parcel to be acted upon.

### Example:

From the Northwest Corner of Section 10, Township 10 South, Range 2 West, Tallahassee Meridian, bear N.45°W. a distance of 10.00 feet to the intersection thereof with the Centerline of United States Highway 90 (US 90) as per Florida Department of Transportation Right of Way Maps for Section 02601-256-456 having a latest date of January 1, 1956; thence N.45°E. along the said centerline a distance of 10.00 feet to the intersection thereof with the centerline of Fred Street as shown on the recorded subdivision plat of Fred's Subdivision, a subdivision as recorded in Plat Book 34 on Page 23 of the Public Records of Leon County, Florida; thence S.45°E. along said the centerline of said Fred Street, a distance of 10.00 feet to the intersection thereof with a line which lies 10 feet Southeasterly of and parallel with the centerline of said US 90; thence S.45°W. along said parallel line a distance of 10.00 to the Point of Beginning.

### Pros and Cons:

Pros: parcel can be located with a certainty; the description can be mathematically checked; the size of the parcel can be determined without the use of any additional maps or deeds; and one has a sense of the on-site physical visual object (keys) to help determine its location and allow the layperson a sense of understanding.

Cons: requires a high degree of skill to prepare properly, requires a high degree of skill to read and understand what is being said; requires an even higher skill to know the law concerning the location of the parcel (to be able to determine what words control the location should something not match the view of the author); requires extensive additional materials outside of the description itself to check and confirm the correctness of the description and, in most cases, requires a survey prior to description preparation.

See Appendix for '[Summary of Legal Descriptions](#)'

---

# Interpretation of Real Property Descriptions

---

## Description Word Definitions

Any written document consists of various words used in particular sequence to convey a meaning. The words will have a particular meaning to both the author and to the reader and to another reader, they may not mean the same thing. The understanding of the meaning of those words and the phrases used is very important to the successful understanding of descriptions.

The thorough understanding of the meaning of words and phrases is crucial to the interpretation of descriptions. Words that we all may use and are familiar with but which we may not have known the legal interpretation.

Various dictionaries have been printed over the years to help clarify the definitions of words from a legal point of view; which may be different from the common point of view as contained within a standard dictionary. There are several which come to mind or are contained in various reference books on the subject. They are:

- a. Ballentine's
- b. Black's
- c. Bouvier's
- d. Burrill's
- e. The American and English Encyclopedia of Law

We will list some of the common terms used within legal descriptions below and on the following pages. Since we cannot possibly discuss all the definitions of words found in legal dictionaries here we strongly suggest that you or your office acquire a copy of a law dictionary you feel serves your needs.

**Adjacent:** (Wattles, Page 3.5 - Blacks: Page 38): Lying near or close to; sometimes neighboring. Adjacent implies that the two objects are not widely separated, though they may not actually touch, *Harrison v. Guilford County*, 218 N.C. 718, 12 S.E.2d 269, while adjoining imports that they are so joined or united to each other that no third object intervenes. *Wolfe v. Hurley*, D.C. La., 46 F.2d 515,521. Sometimes it is convenient to state what something is not, not what it is. That is the case in the last portion of this definition.

**Adjoining:** (Wattles, Page 3.5 - Blacks: Page 39): The word in its etymological sense means touching or contiguous, as distinguished from lying near or adjacent. To be in contact with; to abut upon. *State ex rel. Boynton v. Bunton*, 141 Kan. 103, 40 P.2d 326, 328. The same meaning has been given to it when used in statutes. Etymological means the derivation of a word, the study of historical linguistic change and the study of the true meaning of words.

---

## Interpretation of Real Property Descriptions

---

**Along:** (Wattles, Page 3.7 - Blacks, Page 71) Lengthwise of, implying motion or at or near, distinguished from across. By, on, up to, or over, according to the subject-matter and context. The term does not necessarily mean touching at all points; nor does it necessarily imply contact. If a description says: "... along the easterly right-of-way Line of Old Town Road.." and a quick review of the right of way maps shows multiple angle deflections as the road right of way width increases and decreases, does the description run along all the "ins and outs" of the right-of-way or does it go with a straight line? Generally, the courts have held that the meaning or intent is to follow the idiosyncrasies of the called for line. Again follow the meaning and intent of the whole instrument.

### **Azimuths:**

Bearings are limited in angular size by ninety degrees and they do not lend themselves to determining the angular relationship among all the lines in a description with one simple computation. Therefore, mathematicians came up with the azimuth means of referring direction. Azimuths are based on the fact that in the sexagesimal system of measurement there are 360 degrees in a full circle and that the circle will not increase to more than 360 degrees. The grad system of measurement can use azimuths that are based on 400 total degrees in a circle.

United States Army Corps of Engineers Method -

One of the problems with azimuths is that they can be counted from multiple points of the circle, normally either North or South as zero azimuth and that they may be counted in either direction from the zero point - either clockwise or counter clockwise. The Army Corps of Engineers counts North as zero azimuth and increases the degrees clockwise. South of the equator a South azimuth is used as zero because that is the way the compass needle points.

### **Bearings:**

Geodetic or True (bearing basis) - True bearings are generally considered to be based on astronomical bearings and are based on "sun shots" or "star shots."

Grid (State Plane) - These are becoming more and more prevalent in today's world due to the use of the Global Positioning System. It means that the bearings in the description or in the survey drawing are based on those bearings one computes when using the state plane coordinate system.

Magnetic (compass) - Not really used much today though some older deeds will have their bearings based on magnetic. In that case, one would be better off trying to plot the description by using the distances as much as possible.

---

## Interpretation of Real Property Descriptions

---

*(Bearings: continued)*

Reference by Specific Line in Description - This method is the most common. The author of the description simply says I assume that the bearing of a line has a specific direction and the entire description is based on that assumption.

Reference by Specific Line Outside of Description - There is no rule that says the line whose direction is being assumed in the description has to be a part of the description. The author may want to make sure that the reader of the description knows that the description should be controlled by the direction of the line some distance away and not connected to the description.

Reference Lacking - Unfortunately, most attorneys and title companies who prepare conveyances do not make the description sketch that is part of the survey a part of the conveyance. Also, they rarely record the actual description they receive from the surveyor which includes the basis of bearing note and other pertinent facts made a part of the description by the surveyor. Nothing requires the inclusion of the bearing basis note, it is just a helpful piece of information when mapping the description.

North (Wattles, Page 3.8 - Black, Page 956) - Just what does “North” mean? Assume you have a quarter’s quarter parcel that an owner received via a sectional breakdown description and sold that same land via metes and bounds descriptions similar to: “Begin at the SE cor, thence west 10 rods, thence north 80 rods thence along quarter line 10 rods, thence south 80 rods.” and “Begin at the SE cor, thence west 10 rods to beginning, thence West 20 rods, thence north 80 rods, thence east 20 rods on quarter line, thence south 80 rods.” If the section were one of those perfect sections, where everything is North/South and East/West and 5280 feet long along all four sides then everything would appear correct. However, not many sections are that way. So what does “West”, “North”, “East” and “South” mean in those descriptions?

North, Due (Wattles, Page 3.8 - Blacks, Page 448): “Just; proper; regular; sufficient; reasonable ...” And the rest of the definition refers to things mainly concerning money. Generally doesn’t seem to refer to description writing does it? Black definition for “North” relates “...due North; opposite direction of south. Same with word northerly.”

True or Geodetic North (Wattles, Page 3.8 - Blacks, Page 1351): “Conformable to fact; correct; exact; actual; genuine; honest. .... a synonym of honest, sincere, not fraudulent...”. True bearings are generally considered to be based on astronomical bearings and are based on “sun shots” or “star shots.” The word “due” gives the impression of almost, but not quite accurate, where as “true” relates as the most accurate. In older descriptions, “due” tends to mean a magnetic direction and “true” means astronomical, but that is not always the case.

---

## Interpretation of Real Property Descriptions

---

**Between:** (Wattles, Page 3.8 - Blacks, Page 146): “A space which separates. Strictly applicable only with reference to two things....As a measure or indication of distance, this word has the effect of excluding the two termini...”

Blacks also includes the definition of: “Sometimes used synonymously with ‘among’”.

Common sense example:

“...between the City of Punta Gorda City Limits and the Intracoastal Waterway Right of Way...” This is definitely a separating space as the distance is several miles.

**Contiguous:** (Wattles, Page 3.5 - Blacks, Page 290): “In close proximity; neighboring; adjoining; near in succession; in actual close contact; touching at a point or along a boundary; bounded or traversed by.”

**Contiguity** (from Wattles, Page 3.5): “... as one parcel contacting another.”

A lot of description authors use the words adjacent when they mean contiguous and vice versa. It looks like adjacent would not be a good word if one is describing parcels that should be coincident with each other, contiguous would be a better word to use. Remember that no matter what the dictionaries say a word means, it’s really the reading of the whole document that controls as well as the intent of the parties involved.

**Conveyed and Described** - (Wattles, Page 3.6, Blacks, Page 301/Page 401)

Again we have a case where the author of a description may have used the two words above in a manner different than what the meaning of the words would indicate.

Conveyed: “... to the intersection of the lands conveyed by Official Records Book 5162 Page 235...” means to intersect with the lands actually conveyed by that particular document.

Described: “... to the intersection of the lands as described in Official Records Book 6892 Page 1029...”; one needs to look up the description contained in that recorded document and intersect with it.

Just because one describes it doesn’t mean that the title actually transfers. The land described and the land conveyed may actually be different lands. For plotting purposes, you would assume that they are one and the same in the absence of evidence to the contrary.

**Each** (Wattles, Page 3.9 - Blacks, Page 455): “A distributive adjective pronoun, which denotes or refers to every one of the persons or things mentioned; every one of two or more persons or things, composing the whole, separately considered. ... The word “any” is equivalent to “each.” Conerty v. Richtseig, 308 Ill. App. 321, 31 N.E.2d. 351.”



---

## Interpretation of Real Property Descriptions

---

**Either** (Wattles, Page 3.9 - Blacks, Page 463): “Each of two; the one and the other; one or the other of two alternatives; one of two. Often used, however, with reference to more than two, in which case it may mean ‘each’ or ‘any.’”

**On** (Wattles, Page 3.8 - Blacks, Page 981): “Upon; as soon as; near to; along; along side of; adjacent to; contiguous to; at the time of; following upon; in; during; at or in contact with upper surface of a thing.”

**To** (Wattles, Page 3.8 - Blacks, Page 1333): “While this is normally a word of exclusion, when used in describing premises, it has been held that the word in a statute may be interpreted as exclusionary or inclusionary depending on the legislative intent as drawn from the whole statute. *Clark v. Bunnell*, 172 Colo. 32, 470 P.2d 42, 44. It may be a word of inclusion, and may also mean ‘into’.”

### Description Phrase Definitions

#### **"...along the water's edge..."**

What edge? The mean high water line? The location of the water when the author of the description was last at the water body? The mean low water line? Chances are that it is the water's location at the time the author was last there. This may create a strip of land between the water's edge as contained in the description and the actual limit of title (mean high water line or ordinary water line). Be very careful when interpreting calls such as this.

#### **"...each side of each lot line..."**

Just what does this mean? Are the front and rear lot lines included? Can one read the entire document and get a better understanding of what was intended by the author? If not, then the literal interpretation needs to be applied. EACH side of EACH lot line has the item involved. Do NOT use your own personal idea or understanding of the term.

#### **"...excepting and reserving..."** (Wattles, Page 3.10, Blacks, Page 501/1175) –

Many deeds contain the phrase: “..excepting and reserving...” whatever, normally after the body of the description as a limiter of the rights granted. The problem arises in the fact that the two words normally mean different things. Excepting generally means to exclude where

## Interpretation of Real Property Descriptions

---

reserving generally means the entire thing is limited by the rights reserved. Reserved does not generally mean to exclude.

If one wanted to preserve the right to use a driveway of a width of 20 feet along the eastern side of a lot, then one shouldn't except that 20 feet from the transfer of the lot. Simply reserving that 20 feet to oneself would be sufficient. However, once again, read the entire document to ascertain if the author intended to limit the transfer to all but the item(s) "reserved."

**"...except the interest in..."** (Wattles, Page 3.11) –

Rarely used, but still could be a problem. A cause generally used by government in the acquiring of land where in they want to acquire only certain rights (similar to an easement) and not to acquire full fee simple title. The older Florida Power & Light Company's prepared transmission line documents generally state that the grantor (the land owner) is granting to them a "right of way easement." Well, just what is a right of way and just what is an easement? You should read the entire document to determine the intent.

Example:

When the Intracoastal Waterway was built in the 1940's thru the 1960's the government acquired various rights to dump spoil on mangrove islands, cut through privately owned islands and to use those parts of the uplands which fell within the width proposed for the waterways right of way. For years, most understood that the governmental entity acquired the fee simple title to all they included within their right of way maps and descriptions. So did the landowners as they excepted the lands included within the right of way of the Intracoastal Waterway when they sold their land. The attorneys preparing deeds also excepted the lands since they didn't correct the land owner's perception.

However, upon research of the status of that land by reviewing the actual condemnation court case in the public records it was found that the judge's instructions to the jury revealed that the government was seeking an easement across the owner's land, not a fee simple interest despite the term "right of way" used in the government's documents. You may need to research back to the original documents to determine what the original intent was.

## Interpretation of Real Property Descriptions

---

### **“...front and rear...”** (Wattles, Page 3.11) –

As Wattles says, they “... are not satisfactory words to use because of their indefiniteness.” Never the less, many people have used them particularly in easement dedication descriptions.

Example: “There are hereby expressly reserved easements of 10' feet along the front and rear lot lines and 12' feet (6.0 ft each side of and parallel to each lot line) for drainage ....”

You would have to look at the plat to determine which is the front and which is the rear lot lines. Usually the intent is for the “front lot line” to be along the roadway or entrance to the lot; the “rear lot line” being the back of the lot.

### **“...in a straight line...”** (Wattles, Page 3.11) –

Wattles says this phrase is unnecessary except in rare occurrences. It is used to indicate that the author wanted to follow a straight (without bends) line between two points. It is an indicator of intent.

### **“...more or less...”** (Wattles, Page 3.12) –

According to Black’s Law Dictionary (Page 910), the phrase means “About; substantially; or approximately; implying that both parties assume the risk of any ordinary discrepancy. The words are intended to cover slight or unimportant inaccuracies in quantity, *Carter v. Finch*, 186 Ark. 954, 57 SWAT 408; and are ordinarily to be interpreted as taking care of unsubstantial differences or differences of small importance compared to the whole number of items transferred.”

In acreage figures the phrase is normally used to reflect that no measurement is exact and to make each party aware that there may be small differences.

Otherwise, it is used to reflect the intent of the author. With the description call running to a monument, the location of the monument controls the terminus of the line, not the length. Therefore, the distance is adjusted to meet the monument.

Also, the term “more or less” is often used by a description author to indicate to the reader that the author had some degree of uncertainty about an object, its location, direction or length to same or to control where the author wanted any discrepancy to be placed.

## Interpretation of Real Property Descriptions

---

### **...to the highway..." –**

Just what does this mean? To the closest right of way line? To the furthest right of way line? To the centerline? To the Department of Transportation centerline survey line? To the centerline of construction? To the lands acquired by deed for the highway? To the lands acquired by condemnation? Just what does the call "to the highway" entail?

Only through reading the entire document can one make an educated guess as to the intent of the author. If the distance called for in the description comes closest to either of the items mentioned above, then one may assume that was the object intended by the author. Another thing to look for is the later calls in the description. You may find a call that tells you that the author is leaving the centerline and going on another line. If so, then it would be reasonable to assume that the previous call was to the centerline.

### **"...to the shore..."**

The shore is defined in Black's Law Dictionary (Page 1236) as: "Strictly and technically, lands adjacent to the sea or other tidal waters. The lands adjoining navigable waters, where the tide flows and reflows, which at high tides are submerged, and at low tides are bare. *Shively v. Bowlby*, 152 U.S. 1, 14 S.Ct. 548, 38 L.Ed. 331. The space bounded by the high and low water marks. *Borax Consolidated v. City of Los Angeles, Cal.*, 296 U.S. 10, 56 S.Ct. 23, 80 L.Ed. 9. And this is also true even though the lands may lie along non-navigable bodies of water. Under the civil law the 'shore line' boundary of lands adjoining navigable waters is the line marked by the highest tide. ..."

So if the description says to the shore, it may fall short of the mean high water line or short of the ordinary high water line. That would create a strip of land of varying width between the limit of the description and the limit of sovereign ownership. One needs to read the entire description to determine in your mind if the author of the description intended to create such a strip.

# Interpretation of Real Property Descriptions

---

## Miscellaneous Description Information

### Halves:

Half of what? The distances along the sides? The right angle distance? The area?

#### In Public Land -

While the federal government still owns the land, assuming that they never gave it up, the half is determined by dividing the opposite from the called half lines by two and drawing a line between those points. Sectional breakdown method or also called aliquot parts.

*(Halves: continued)*

#### In Private Land -

Normally the same thing will occur for all other lands owned by private entities. You may find cases where the author provides sufficient information to overcome the general assumption.

#### Acreage -

The only time one uses acreage as the determining factor in sizing the “half” is in a will document or if sufficient evidence is provided in the document that clearly requires the use of acreage to determine the half. Even the will document assumption can be overcome with the evidence in the document.

## Interpretation of Real Property Descriptions

---

### **Unwritten Words:**

There are some words are un-necessary since they are ALWAYS clearly understood to ALWAYS be the case.

#### Right Angles -

A call of the South 50 feet of ... includes the understanding that the 50 feet is to be measured at right angles to the item. If it is not to be at right angles, then the author will or should have provided a means of how one is to measure the 50 feet. “The South 50 feet of the .... as measured along the West line of ....” is a fair example.

#### Tangent -

It is understood that all curves are tangent to the preceding call (either a line or a curve makes no difference). If the curve is not tangent, then the author will call, or at least should have called, the reader’s attention that it is not tangent.

#### Prolongation -

Parallelism is not limited to the confines of the lines under discussion. It is not necessary for the author to have said “...parallel with the Westerly prolongation of ...” a particular line. According to the main reference, it is understood that in order for a call to work that a line may need to be prolonged or a curve continued, then it will be prolonged or continued just as if that prolongation or continuance was actually stated contained within the description. Therefore, it is an unnecessary set of words that may confuse the clear understanding of the lands being described.

## Who Writes Descriptions?

Actually, just about anyone can write descriptions such as just about anyone can write letters. However, people generally rely on those which have some expertise in the area. Just who has the expertise?

### **Individuals:**

With all due respect, those with no knowledge of the legal meaning of words or of the mathematics involved create descriptions create some of the worst descriptions.

### **Engineers:**

Just because engineers are closely associated with surveyor and mappers due to the nature of their mutual services does not necessarily make them good authors of descriptions. Engineers are not trained in property law or the legal meaning of words used in descriptions. Nor are they trained in the complete set of mathematical tools necessary in today's world to properly prepare descriptions.

### **Attorneys:**

Attorneys are trained in the law of words and in the use of words to achieve a particular purpose. Remember that Wattle's says a description is "...the proper grouping of words which delineate one specific piece of land..." Since a description is a grouping of words, one would think that attorneys would be one of the best persons to write descriptions.

### **Surveyors:**

Only surveyors are fully trained in the law of words, in property law, and in the mathematics necessary to properly prepare descriptions. The marrying of those two functions is unique under the training given to surveyor and mappers. In the state statutes and administrative code, surveyors are the only ones which have any comment whatsoever concerning the preparation of descriptions.

# Interpretation of Real Property Descriptions

---

The following is taken from the Florida Administrative Code:

**5J-17.052 Standards of Practice – Boundary Survey Requirements.**

(6) Descriptions/Sketch to Accompany Description:

- (a) Descriptions written by a surveyor and mapper to describe land boundaries by metes and bounds shall provide definitive identification of boundary lines.
- (b) When a sketch accompanies the property description, it shall show all information referenced in the description and shall state that such sketch is not a survey. The initial point in the description shall be tied to either a government corner, a recorded corner, or some other well-established survey point.

This is the link for the Florida Rules pertaining to Surveying and Mapping:

<https://www.flrules.org/gateway/ChapterHome.asp?Chapter=5J-17>



# Interpretation of Real Property Descriptions

---

## Fundamentals of Descriptions - Quiz

1. How would you describe a property description?  
\_\_\_\_\_
2. According to Wattles, what must a “legal” description be able to do?  
\_\_\_\_\_
3. A \_\_\_\_\_ describes a parcel of land totally by reference to other parcels already on record in the public repository.
4. A \_\_\_\_\_ description provides the direction and distance of each course around a figure and relates the monuments that control that figure.
5. A \_\_\_\_\_ uses solely the name of the parcels as shown on a recorded document that divided a larger parcel in accordance with state law.
6. What are the names of the two projections used for the Florida State Plane Coordinate system? \_\_\_\_\_
7. What projection would you utilize for the panhandle portion of the state of Florida?  
\_\_\_\_\_
8. In the coordinate system a rectangular grid is developed that covers an entire state or a portion of a state, this grid is called a \_\_\_\_\_.
9. A description using calls to adjoining titles and boundaries and which also contains bearings and distances in order to describe a parcel would be called a \_\_\_\_\_ description.
10. Word meaning “touching or contiguous”. \_\_\_\_\_

## Interpretation of Real Property Descriptions

---

11. Word meaning “lying near or close to”. \_\_\_\_\_
  
12. The Army Corps of Engineers counts \_\_\_\_\_ as zero azimuth and increases the degrees \_\_\_\_\_.
  
13. Grid bearings are based on those bearings one computes when using \_\_\_\_\_.
  
14. \_\_\_\_\_ bearings are generally considered to be based on astronomical bearings and are based on “sun shots” or “star shots.”
  
15. What words are used in property descriptions to cover slight or unimportant inaccuracies in quantity? \_\_\_\_\_
  
16. The \_\_\_\_\_ in the description shall be tied to either a government corner, a recorded corner, or some other well-established survey point.
  
17. A reciting of a line by metes and bounds together with the widths of the parcel being included on one or both sides and that does not return to the point of beginning is an example of what type of description?  
\_\_\_\_\_
  
18. What term generally means the entire parcel is limited by the rights described.  
\_\_\_\_\_

## **METES AND BOUNDS DESCRIPTIONS**

In this chapter we will discuss the history of the metes and bounds descriptions, their evolution, the format of a standardized description, why they may be worded the way that they are, and some things to help you read and understand the description style.

### **Original Concept**

Centuries ago a buyer and seller would walk the perimeter of a tract and observe the monuments or place new ones and consummate the transfer with the seller picking up a stone or twig from the land and handing it to the buyer. Later they would describe the land in a document and walk the lines. The walking and transfer of objects from the lands involved was called the action of "livery of seizin." It was common in England, but was not continued by the colonists of the new world. This was the "bounded" portion of the metes and bounds description.

Originally, adjacent land owners, trees, rocks, rivers, traveled ways, and so forth were used to describe the perimeter of the property, this was known as a Reference Description. With the development of better equipment that reduced cost, the evolution of surveying techniques, and the desire of the public to more accurately define what they were doing, the addition of the "metes" portion to the metes and bounds description became feasible. By the time of the break with England, the metes and bounds description was prevalent in, what was to become, the United States.

The system of metes and bounds is and was used to survey and describe land in the original thirteen colonies, Kentucky, Texas, West Virginia, Tennessee, Maine, Hawaii and parts of Ohio. Corners were usually artificial landmarks not of a permanent character. Trees, stumps, bends in creeks, etc., were used and they tend to disappear or change over a time span of several generations. Items of a permanent nature were seldom used and the surveyor and mapper's notes of a survey of the land were often incomplete. People simply didn't have the concept of permanence in their minds as far as descriptions were concerned.

They knew what they are transferring and that was as far as their minds would carry it. Also, while considerably better than earlier equipment, the surveying equipment of the time was, shall we say, less than accurate. All of this caused the founding fathers to create another system called the Public Land Survey System.

In the eastern United States, individuals first acquired land titles by gift or purchase from the European governments that were trying to establish colonies. Surveys and maps were either lacking or inadequately made, and descriptions could be given only in general terms. The remaining land in the thirteen colonies was transferred to the states at the close of the Revolutionary War. Later, this land was parceled out to individuals, usually in irregular tracts.

## Interpretation of Real Property Descriptions

---

Many original transfers, and subsequent ownerships and subdivisions, were not recorded. Those that were legally registered usually had scanty or defective descriptions and the trees, rocks, and natural landmarks defining the corners were soon disturbed. Numerous problems in land surveying stem from the confusion of early property titles, descriptions, and poor surveying equipment. The locations of many corners have been established by compromise after resurveys or by court interpretation of their original or intended positions. Other corners have been fixed by "squatters' rights" or adverse possession. Many boundaries are still in doubt, especially in areas with relatively low property value.

### **Requirements of a Metes and Bounds Description**

In effect, any description may be accepted as a metes and bounds inasmuch as an area has dimensions and boundaries for its determination; however the term commonly applies to a description which *recites successively the various courses of the boundary* of the area, and the *true metes and bounds* must be so considered. The true metes and bounds is the most perfect form of description possible for defining an area. It will include a full heading and caption, recital of all ties and monuments, whether record or physical, which determine the correct position of the boundary, **all** references to adjacent lands by name and record, and a full dimensional recital of the boundary courses in succession, which must be mathematically correct. This is what may be called the Combined Description method.

Such a description in its completeness is rare, and seldom necessary, but the amount of material incorporated in any case should be sufficient to properly identify the land described and make the title certain with respect to adjoining titles.

Metes and bounds descriptions must have a point of beginning. There just is no way to get around this point. This is the root cause of why the courts have tended to make the location of the point of beginning more important than the rest of the points along the perimeter of the description even though none of them are really more important than another. This point may be marked by a physical object, such as a stake, fence post, or road intersection. In recent years, artificial permanent monuments such as metal pipes, steel pins, or concrete posts have replaced natural features.

Early descriptions, with lengths shown in chains, poles, and rods, are being replaced by measurements in feet and decimals. Bearings, if used, have been referenced to magnetic north, a particular line, grid north or to true north. Current descriptions, although developed with modern surveying technology and equipment, will still often refer to the natural features found. This enables someone other than the surveyor to get a rough idea of where the points are and retrace the approximate route of the description on the ground.

## Format of a Description

Just as a letter or book has various named portions, so does a description of the metes and bounds style. Since there are no formal requirements, the various description authors have tended to be rather free in their use and terms of the various portions of a metes and bounds description. Generally, the basic parts of a metes and bounds description are shown in the example on the next page and described as follows:

**Caption** - This is the part that is normally used to ordinate the reader to the general area of the lands to be included with in the description. The words in the caption can limit or control the words that follow. For example, if the caption said the lands lie within Lee County, Florida and the section, township and range call in the heading or body of the description related lands that could only be in Leon County, Florida, then the call to Lee County would fail. However, if it said: "All that part of Block 44, ..." than the lands included in the description may be limited to that Block 44 even if the description described lands outside of that block.

As an example:

"A parcel of land in the Southeast Quarter of Section 12, Township 01 South, Range 03 West, Leon County, Florida; said parcel being more specifically described as follows: ...".

**Heading** - After one has gotten the reader to the proper general location, this portion gets the reader from the Point of Commencement (if any) to the Point of Beginning. Remember, in a metes and bounds description, one does not have to have a Point of Commencement, but a Point of Beginning is necessary.

As an example:

"From the triangle shaped concrete marker at the Southeast Corner of said Section 12, bear S.89°44'15"W. Along the South Line of the said Southeast Quarter a distance of 1000.00 feet to the Easterly Right of Way Line of Old Town Road as shown on the right of way maps for same prepared by the Leon County Surveyor as recorded in Road Right of Way Book 122 on Pages 088 through 104 of the Public Records of said county; thence, N.00°01'10"W. Along said Easterly Right of Way Line a distance of 100.45 feet to the intersection thereof with the South Line of XYZ Subdivision, a subdivision as recorded in Plat Book 34 on Page 99 of the said Public Records and the Point of Beginning: ...".

## Interpretation of Real Property Descriptions

---

**Body** - This portion generally contains all the various calls around the lands to be included within the description. In a metes and bounds description, the angle and distance of a given line or arc is defined as a “call”.

For example the following portion of a body of a description has three calls:

..... **Thence** N12°45'46"E a distance of 23.45 feet; **Thence** N45°41'56"E a distance of 123.23 feet to the Point of Curvature of a curve concave to the South having a central angle of 73°54'31" and a radius of 1311.29 feet; **Thence** Northeasterly, Easterly and Southeasterly along the arc of said curve, a distance of 1691.50 feet to the Point of Tangency; .....

Some authors, in a lengthy metes and bounds description containing a large number of courses, successively number the courses for ready reference:

Example:

"...thence (1) N 27°E 460 feet; (2) S 88°E 1067 feet; (3) N45°E 560 feet; (4) N 56°W 267 feet....."

The absence of the word “thence” with these courses does not mean these are not a call in the description.

**Closing (also known as Qualification) Section** - After one is returned to the Point of Beginning or the Point of Termination is reached, sometimes the author may feel that various statements are necessary to make the reader more knowledgeable of the author’s intent of the extent of the lands included or of the control items under which the description was prepared. Words or phrases like the size of the parcel involved, the method of treating the beginning and starting “cutoff” lines if a strip description, the bearing basis, etc.

# Interpretation of Real Property Descriptions

---

## DESCRIPTION:

**Caption**

A parcel of land lying within Block 44, DeCoster's Addition to Harborview, a subdivision as recorded in Plat Book 1 on Page 24 of the Public Records of Charlotte County, Florida; said parcel being more specifically described as follows:

**Heading**

From the intersection of the Easterly right of way line of Date Street as shown on said plat and the Southerly right of way line of Harbor View Road (AKA: Lime Street, State Road 776 and County Road 776) as shown on the right of way maps of State Road 776, Section 01560-2601 (being the same point of commencement as the description contained within Official Records Book (ORB) 0558 on Page 0892, said Public Records), bear N.89°29'37"E. along the said Southerly right of way line, a distance of 100.00 feet more or less to the Northwest Corner of those lands described within said ORB 0558 on Page 0892; thence continue N.89°29'37"E. along said Southerly right of way line a distance of 86.00 feet more or less to a point which lies S.89°29'37"W. a distance of 114.00 feet from the Northeast corner of those lands as described within said ORB 0558 on Page 0892 and to the POINT OF BEGINNING:

**Body**

thence continue N.89°29'37"E. along said Southerly right of way line a distance of 114.00 feet to the Northeast Corner of those lands described within said ORB 0558 on Page 0892; thence S.00°22'54"E. along the Easterly line of those lands as described within said ORB 0558 on Page 0892, a distance of 99.86 feet more or less to the intersection thereof with a line which lies 30 feet Northerly of and parallel with the Southerly line of those lands as described within said ORB 0558 on Page 0892; thence S.89°28'56"W. along said parallel line, a distance of 114.00 feet; thence N.00°22'54"W. parallel to the said Easterly line of those lands as described within said ORB 0558 on Page 0892, a distance of 99.88 feet more or less to the POINT OF BEGINNING.

**Closing**

Containing 0.261 acres, more or less.

The bearings as shown herein are based on the centerline of Harborview Road being N.89°29'37"E.

## Reference Descriptions

A short discussion of this method of describing land is necessary in any paper presented that purports to discuss descriptions. However, the method never really got started in Florida since neither the English nor Spanish were here long enough or organized well enough to get their colonies fully started, although Saint Augustine is the oldest continually occupied city in North America.

Problems -

The following is taken from the book by Francis J. Marschner, *Boundaries and Records in the Territory of Early Settlement from Canada to Florida*: "...a check of the records by the Surveyor-General revealed that in three of these counties the grants totaled more than ten times the land area of the individual counties..."

And from the same book: "Land ownership was poorly defined in the Carolinas as in other colonies. The metes and bounds surveys for the deeds were frequently executed without attempting identification or correlation of the survey with the boundaries of adjoining properties. This haphazard method and lack of systematic procedure necessarily caused confusion and controversy among the settlers and in the end led to court action."

The only way to solve the problems without extensive surveys which all persons would accept was to call out in the description (to reference) one's neighbor's land as the end of one's own land. This is what they started to do.

This method created another problem. People wanted to keep the cost of selling land low, so they started to bypass the surveyor and mapper. They started writing their own descriptions similar to: "All my lands in Jefferson County, Virginia that lies between Falstead Creek and Jones's fence bounded on the East by W.L. Thompson and on the West by Green Hill Road." It would be difficult to find this tract of land without an extensive review of the courthouse records and possible discussions with the adjacent land owners. As is typical with low cost methods of transferring land without full surveys, the cost to survey land in these states actually went up due to the extra effort needed to correctly determine the location of the described land.



## How to Read a Metes and Bounds Description

Metes and bounds land descriptions are read like a story in which there is a preamble (caption), a beginning (heading), the plot thickens (body), and an end (closing). Most confusion in interpretation of description calls occurs because of the variations in terminology and abbreviations found in deeds and survey descriptions over the years. That is why we went over the meaning of words earlier in the fundamentals of descriptions. If you have not studied those words, do so and if you don't have a legal dictionary available to you at your office, get one.

The caption serves as an introduction to the description and contains a general location reference to indicate to the reader where the lands are located. It may site the section, township, range, city (optional), county (optional), state (optional) or meridian (required if the previous items are left out) or some other such indicator like a subdivision's name and recording information. It may also contain a parent tract citation, being a recital of the book and page in the public records of the tract from which the new parcel is partitioned. The caption serves as a legal limit to the lands conveyed such that if the body of the description included lands located outside of those captioned, only the captioned land is transferred. It usually ends with the words "*...more particularly described as follows:...*" or "*...being more specifically described as follows:...*".

The heading, if any, contains the calls necessary to get one from the point the description starts to the point of beginning of the description. It is not required as the description may begin at a point on the perimeter of the lands being described. It will be started with a point of reference (or commencement) which is used to reference the parcel to some well-established point. Such a point may typically include a government survey corner, a long established artificial monument or the intersecting points of two streets, whatever the author felt was unmistakable, then the calls necessary to get the reader "*to the point of beginning*". If it is present, it will usually end with the words "*...to the Point of Beginning:...*" and if it is not, then it will usually start with the words "*Begin at...*" or "*Beginning at...*".

The body of the description is made up of the number of changes of direction (calls) necessary to traverse around the subject parcel. The sequence of the described courses traversing the parcel follows the point of beginning in the same paragraph, with the last course returning "*to the point of beginning*".

Metes and bounds descriptions also usually contain *qualifying clauses* (closing) such as exceptions to the lands to be included within the description, reservations, acreage, conditions the author imposes on the description. These may include statements of content (acreage or square footage), exceptions, easements, and other restrictions upon use of the property.

## Interpretation of Real Property Descriptions

---

Descriptions found on a deed may be divided into two or more parts or parcels for convenience in form or for segregation with respect to other considerations in the document. Usually, a well written description will separate fee and easement parcels, for example.

### Direction

The calls in a metes and bounds descriptions are read in the order they are written and may include direction and distance. The *direction* of a line may be given by its angle from an established line of reference, called a meridian. This reference line can be the true (geographic) meridian, the magnetic meridian, a grid meridian or assumed as most descriptions are written today. The true meridian for any one place on the surface of the earth is a line that passes through the observer's position and the North and South geographic Poles. If a survey is based upon a plane coordinate system, such as a state plane coordinate system, a grid meridian is used as the reference meridian.

The bearing of a line is the angle between the meridian and the line measured from either the north or south toward the east or west (see diagram on next page). Bearings are generally expressed in degrees, minutes, and seconds (normally in the United States, each degree is divided into 60 minutes; each minute is divided into 60 seconds) and may be written as N.89°52'30"W. Unless the metric system is used, a United States bearing will never exceed 90° in a property description and is always given from the north or south to the east or west.

Some descriptions contain *angles* (rather than bearings), which represent the angle measured in the field by a surveyor and mapper. These angles refer *back* to the previous line rather than to a meridian. Examples of field angle usage in descriptions include:

Deflection angles which are measured between a line and the prolongation of the preceding line. They may be right or left. Without including the metric system, each one will never exceed 360°. The algebraic sum of the deflection angles in a polygon is 360°. [See Appendix for deflection angle description in a Warranty Deed.](#)

Angles to the right which are sometimes called azimuths from back lines. They are measured clockwise from the preceding line and are sometimes called clockwise angles. Without including the metric system, each one will never exceed 360°.

Angles to the left which are measured counterclockwise from the preceding line and are sometimes called counterclockwise angles. Without including the metric system, each one will never exceed 360°.

Interior angles which are measured between the lines inside a polygon. Without including the metric system, each one will never exceed 360°. The algebraic sum of all the interior angles is  $((N - 2) * 180^\circ)$ , where N is the number of lines.

## Interpretation of Real Property Descriptions

---

Exterior angles which are measured between the lines on the outside of a polygon. Without including the metric system, each one will never exceed  $360^\circ$ . The algebraic sum of all the exterior angles is  $((N + 2) * 180^\circ)$ , where N is the number of lines.

Today's computerized mapping software allows precise plotting of descriptions, however when using manual mapping tools it is difficult to plot a bearing more accurately than to the nearest half degree without a giant protractor. When using a protractor to measure angles it is necessary to round the bearings or angles to the nearest quarter degree and approximate as best you can.

# Interpretation of Real Property Descriptions

---

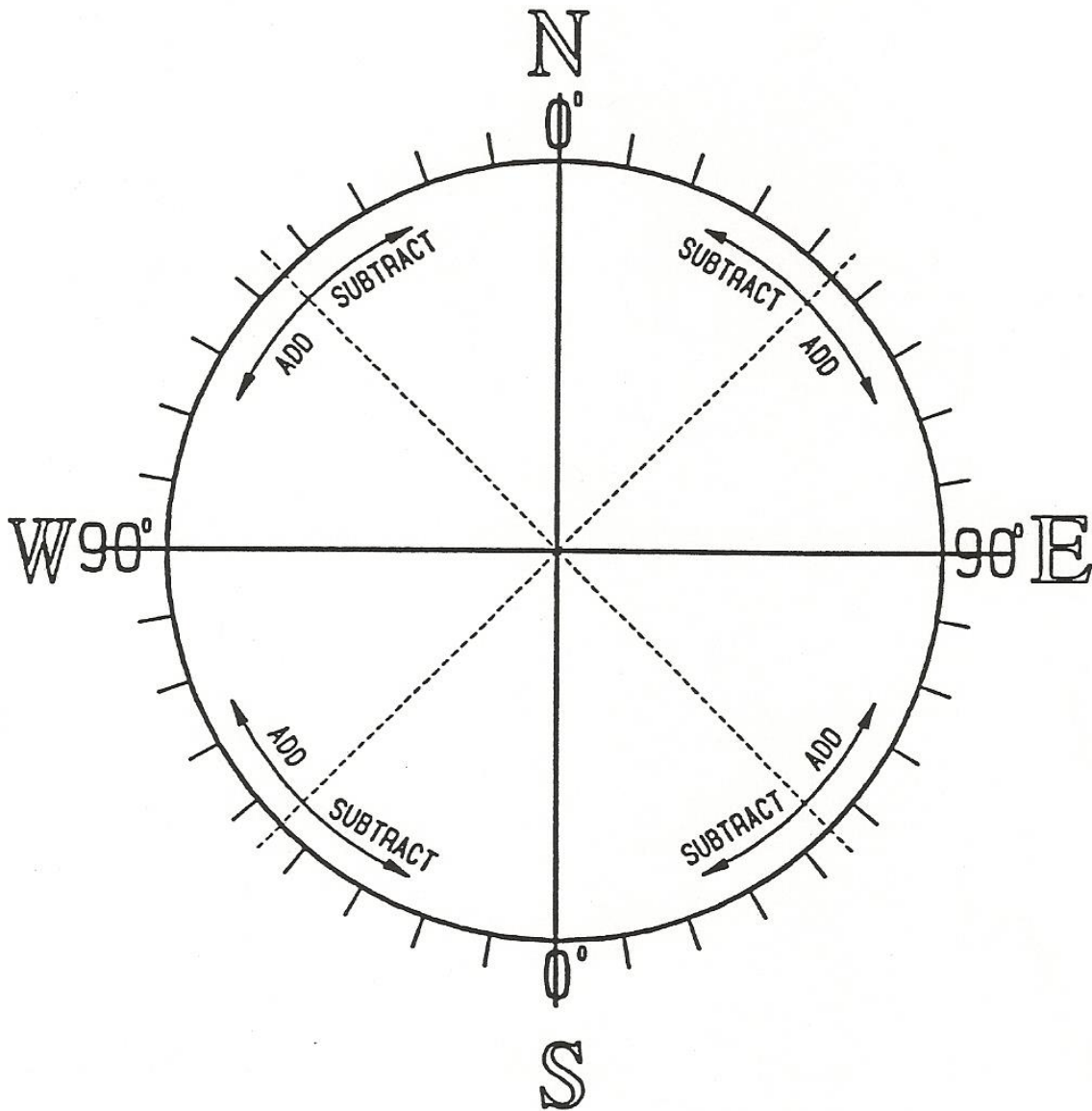

# Interpretation of Real Property Descriptions

---

## **Bearing Directions**

When plotting a metes and bounds legal description where bearings are given you may first calculate the angles between the various calls so as to be able to plot the courses using a protractor or just use the protractor as the angle computer. There are three (3) different rules or methods depending on the bearings given. The following are examples of the three methods:

- 1) Calculating the angle between two (2) courses (lines, tangents, etc.) when bearings are given for the courses and the bearings are in the same quadrant (ie. NE, NW, SE, SW). See Example 1, on following pages.
- 2) Calculating the angle between two (2) courses (lines, tangents, etc.) when bearings are given for the courses, the bearings are in different quadrants and by going from one to the other you would cross the South or North line (ie. going from the NE to NW or SE to SW, etc.). See Example 2, on following pages.
- 3) Calculating the angle between two (2) courses (lines, tangents, etc.) when bearings are given for the courses, the bearings are in different quadrants and by going from one to the other you would cross the East or West line (ie. going from the NE to SE or NW to SW, etc.). See Example 3, on following pages.
- 4) The last one, where one just uses the protractor as the compass or angle turning device is quicker. Just draw a line at the bearing of the first call. Place the protractor over that line (you may have to extend that line to meet the size of the protractor). Align the protractor's center point with the point at which the line turns to the next line. Rotate the protractor's numbers till zero is north. The numbers and direction on the protractor should then match the first line you drew except in the opposite direction. Next, simply determine the direction of the bearing of the next line using the numbers on the protractor. See Example 4, on following pages.

# Interpretation of Real Property Descriptions

## Example 1

### Bearing Calculations

Calculating the angle between two courses (lines, tangents, etc.) when bearings are given for the courses and the bearings are in the **same** quadrant (i.e. NE, NW, SE, SW).

The angle can be calculated by simply subtracting the smaller bearing from the larger. See illustration below:

Course 1 = N 35° 15' 30" E

Course 2 = N 85° 10' 15" E

Subtract the smaller bearing from the larger as follows:

$$\begin{array}{r} \text{N } 85^{\circ} 10' 15'' \text{ E} \\ - \text{N } 35^{\circ} 15' 30'' \text{ E} \\ \hline \text{Angle} = 49^{\circ} 54' 45'' \end{array} \quad \text{OR} \quad \begin{array}{r} \text{N } 84^{\circ} 69' 75'' \text{ E} \\ - \text{N } 35^{\circ} 15' 30'' \text{ E} \\ \hline 49^{\circ} 54' 45'' \end{array}$$

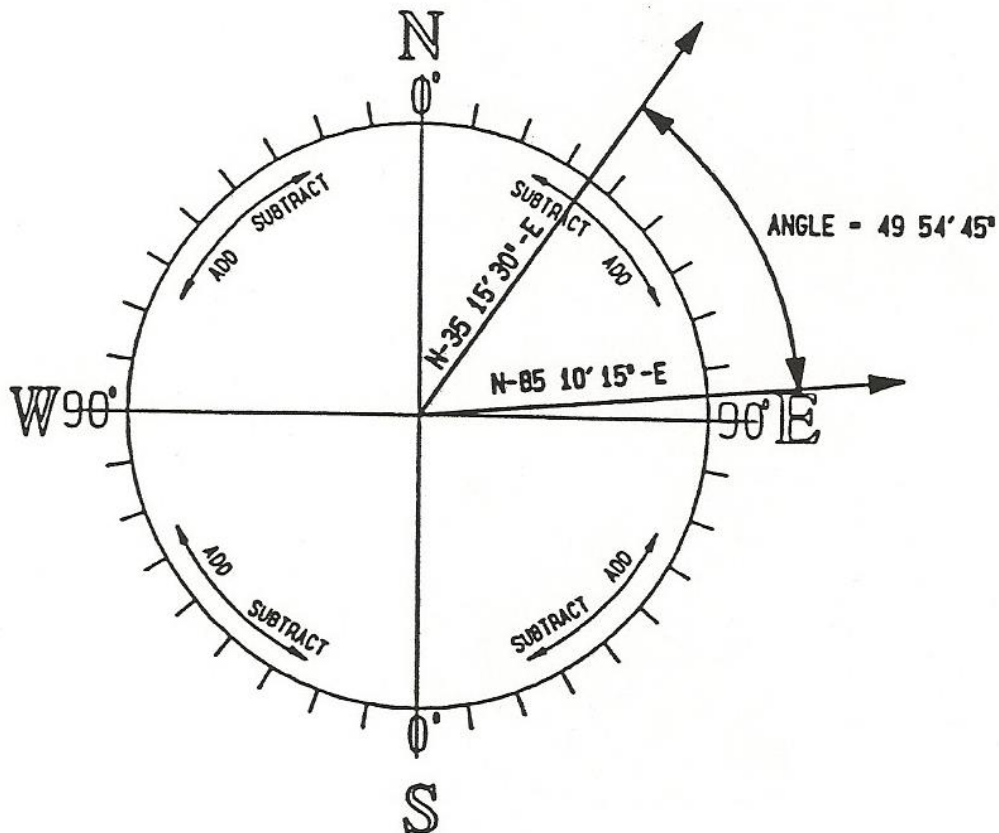

# Interpretation of Real Property Descriptions

## Example 2

### Bearing Calculations

Calculating the angle between two courses (lines, tangents, etc.) when bearings are given for the courses, the bearings are in the **different** quadrants, and by going from one to the other you would cross the South or North line (i.e. going from the NE to NW or SE to SW, etc.).

The angle can be calculated by simply **adding** the two bearings. See illustration below:

Course 1 = N 35° 15' 30" E

Course 2 = N 59° 25' 55" W

$$\begin{array}{r} \text{Add} \quad \quad \quad \text{N } 35^{\circ} 15' 30'' \text{ E} \\ + \quad \text{N } 59^{\circ} 25' 55'' \text{ W} \\ \hline \text{Angle} = \quad \quad \quad 94^{\circ} 40' 85'' \quad \text{or} \quad 94^{\circ} 41' 25'' \end{array}$$

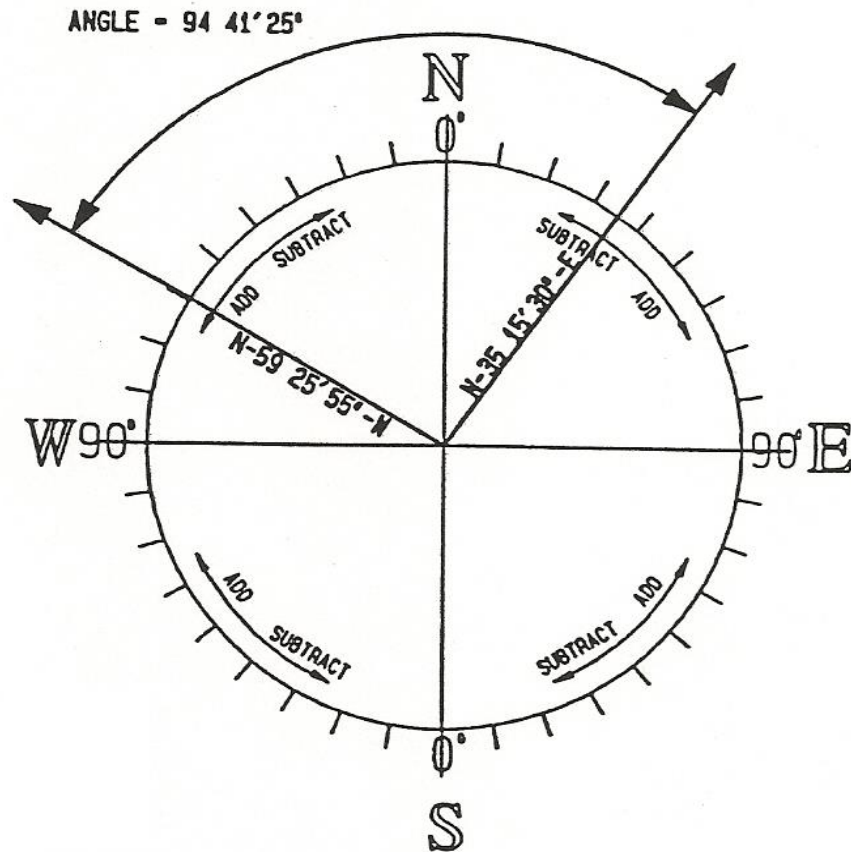

# Interpretation of Real Property Descriptions

## Example 3

### Bearing Calculations

Calculating the angle between two courses (lines, tangents, etc.) when bearings are given for the courses, the bearings are in the **different** quadrants, and by going from one to the other you would cross the East or West line (i.e. going from the NE to SE or NW to SW, etc.).

The angle can be calculated by simply **adding** the two bearings and **subtracting from 180°**. See illustration below:

Course 1 = N 35° 15' 30" E

Course 2 = S 68° 35' 10" E

Add  
N 35° 15' 30" E  
+ S 68° 35' 10" E  
103° 50' 40"

180° = 179° 59' 60"  
- 103° 50' 40"  
Angle = 76° 09' 20"

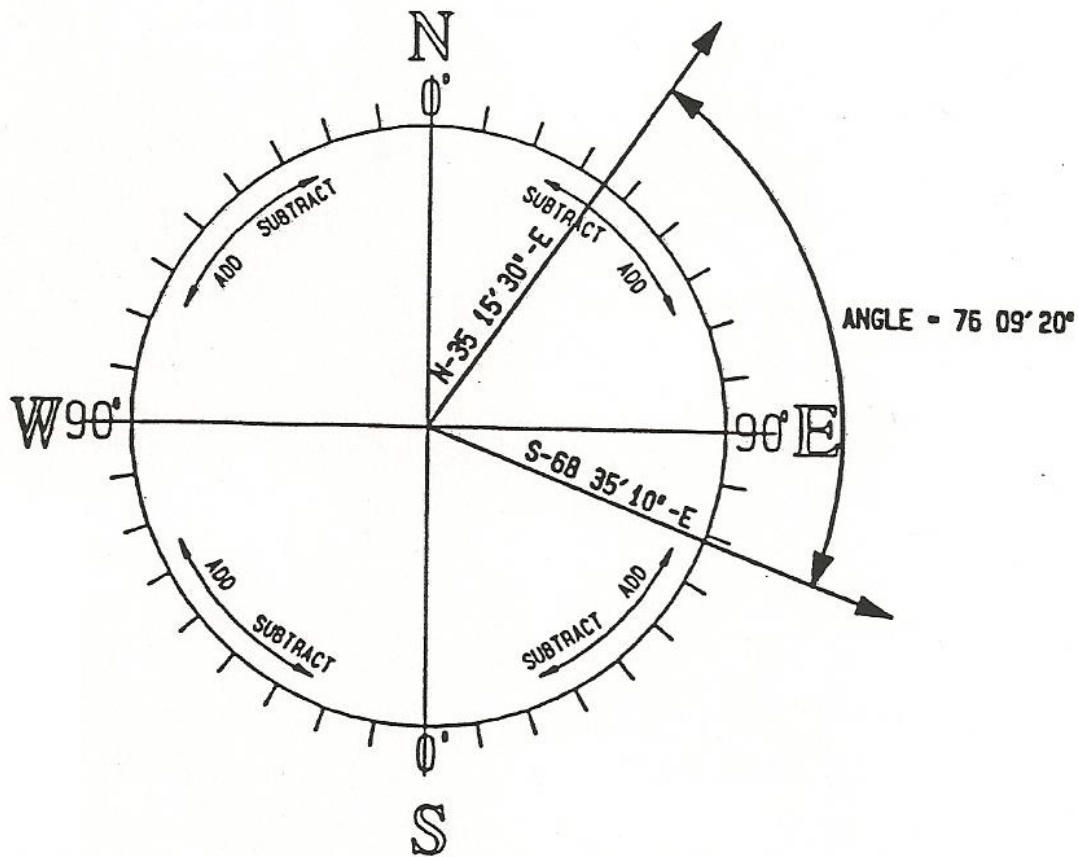



**Example 4**

**Bearing Calculations**

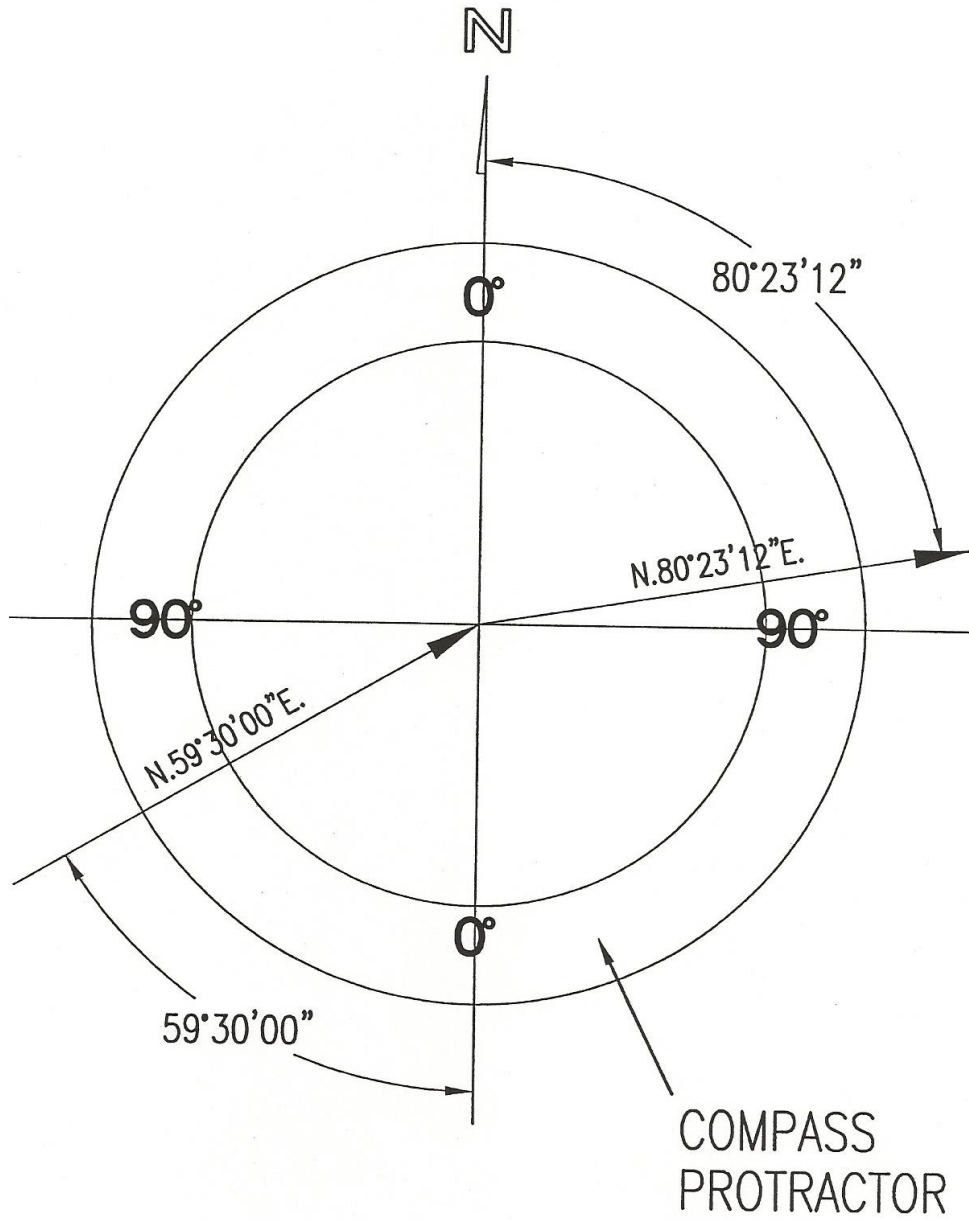

# Interpretation of Real Property Descriptions

---

## **Distance**

The instruments and tools used to measure the land by the government surveyors during the early and late 1800's and early 1900's were crude by today's standards. The purpose for those surveys was to locate and rate the value of the public lands for sale to generate revenue for the government. Deeds of conveyance for these lands were given to purchasers and described multiple sections in multiple townships down to sections and parts of sections. Most subsequent conveyances of properties have been for portions of the original purchases necessitating a metes and bounds or combination description. The metes (measures) portion was recorded utilizing the common unit of measurement for that period which was based on the *Gunter's chain*.

In order to plot descriptions it is useful to refer to a list of the various surveyors' measurements to convert distances to today's commonly used values of feet and *tenths of a foot*. After the line's bearing direction has been established, measure its desired length using an engineer's scale. As with the protractor, some approximation is necessary in this procedure. The point that is established becomes the takeoff for the next course in the description and is repeated until the return to the point of beginning. See page 43 for a table of various different measurement standards and the conversion among them.

---

*Next we will look at measurements, get familiar with our scale, protractor, and land compass. We'll also learn how to calculate chains into feet, measure angles, learn about the surveyor's quadrants, and map out some elementary metes and bounds descriptions.*

---

## Measurements of Distance

Remember, the instruments and tools used to measure the land during the early and late 1800's and early 1900's were crude by today's standards. The distance was recorded utilizing the common unit of measurement for that period which was based on the *Gunter's chain*.

The Gunter's chain measurement is a geodetic system, formerly popular in Britain and its colonies. It was developed in the 17<sup>th</sup> century by Edmund Gunter and is rarely used today in the United States.

Gunter used an actual measuring chain of 100 links (see image below). These, the chain and the link, have become units of their own. A Gunter's chain is 4 rods long, with the rod being a standardized measurement of 5 ½ yards or 16 ½ feet. This rod is also called a perch or a pole.

A Gunter's chain is 22 yards or 66 feet in length. A Gunter's link is 1 chain divided by 100; or exactly 7.92 inches (or 0.66 feet) in length.

In order to plot descriptions it is useful to refer to a list of the various surveyor's measurements to convert distances of chains, links and rods into today's commonly used values of feet, tenths of a foot, and inches. This can be done by utilizing the conversion sheet on the following page.



*Gunter's Chain*

# Interpretation of Real Property Descriptions

## Measurement Length Relationships

Inches	Feet	Yards	Rods*	Miles
12	1	0	0	0
36	3	1	0	0
198	16 ½	5 ½	1	0
63,360	5,280	1,760	320	1

\*Rod or perch or pole

Inches	Feet	Yards	Rods*	Acres	Miles
39,204	272 1/4	30 1/4	1	0	0
0	10,890	1,210	40	0	0
0	43,560	4,840	160	1	0
0	0	0	0	640	1

\*Perch or square rods

7.92 inches                    1 link  
 25 links                        1 rod  
 4 rods                          1 chain  
 10 sq. chains or 160  
 sq. rods                        1 acre  
 640 acres                      1 sq. mile  
 36 sq. miles (6 miles  
 sq.)                              1 township

One link is 7.92 inches  
 One foot is 12 inches  
 One vara is 33.3 inches  
 One yard is 3 feet or 36 inches  
 One rod is 16 ½ feet, 5 ½ yards  
 or 25 links  
 One chain is 66 feet or 4 rods or  
 100 links  
 One furlong is 660 feet or 40 rods  
 One mile is 8 furlongs, 320 rods,  
 80 chains, or 5280 feet  
 One square rod is 272 1/4 square  
 feet or 30 1/4 square yards  
 One acre contains 43,560 square feet  
 One acre contains 160 square rods

One acre is about 8 rods by 20 rods  
 long or any two numbers (of rods) whose  
 product is 160.

One acre may be divided into about 8 lots  
 30 x 125 feet.

5 ½ yards                      1 pole  
 16 ½ feet                      1 pole  
 66 feet                        1 surveyor's chain  
 7.92 inches                  1 link  
 100 links                      1 chain  
 4 poles                        1 chain  
 25 links                       1 pole  
 320 poles                      1 mile  
 1,760 yards                  1 mile  
 5,280 feet                    1 mile  
 160 square rods            1 acre  
 4,840 square yards        1 acre  
 43,560 square feet        1 acre  
 5,645.37 square vara     1 acre  
 70 x 70 yards  
 (approx.)                      1 acre  
 208.71 x 208.71            1 acre  
 640 acres                      1 section  
 4,428.4 acres                1 league

**Let's pull out some information from the previous page that you will find useful.**

**1 Chain** = 4 rods, or 66 feet, or 100 links

**1 rod or pole** = 16.5 feet or 25 links

**1 link** = 0.66 foot or 7.92 inches

**1 mile** = 5,280 feet

**1 acre** = 43,560 square feet

**1 township** = 36 square miles

**1 section** = 1 square mile or 640 acres

# Interpretation of Real Property Descriptions

## DEED DESCRIPTIONS USING CHAINS, LINKS, RODS, ETC.

30154

Printed for Lawyers' Title Guaranty Fund, Orlando, Florida

DEF REC 534 PAGE 287

## Warranty Deed

STATUTORY

This Indenture, Made this 6th day of October 1961, Between

**BETTY JANE BRIDGES and JAMES THEODORE BRIDGES, husband and wife,**  
 of the County of Polk B. State of Florida, grantor, and

**DALTON E. KNOWLES and MARY KNOWLES, his wife,**  
 whose post office address is 1226 West Ruby, Lakeland,  
 of the County of Polk, State of Florida, grantee,

**Witnesseth,** That said grantor, for and in consideration of the sum of TEN Dollars,  
 and other good and valuable considerations to said grantor in hand paid by said grantee, the receipt whereof is hereby  
 acknowledged, has granted, bargained and sold to the said grantee, and grantee's heirs and assigns forever, the fol-  
 lowing described land, situate, lying and being in Polk County, Florida, to-wit:

Begin at the NW corner of the SE 1/4 of NE 1/4 of Section 17, Township 25  
 South, Range 24 East, run thence South 13 chains, thence East 5 chains, thence  
 North 7 chains, thence East 10 chains, thence North 6 chains, thence West 15  
 chains to the point of beginning, less a strip of land 15 feet wide off the South  
 side of the first 5 chains above stated for road purposes. FILED FOR RECORD



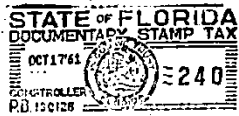

STATE OF FLORIDA  
DOCUMENTARY STAMP TAX  
OCT 17 61  
240  
CONTROLLER  
P.O. 150125

1961 OCT 13 PM 4 11

D. H. SLOAN, JR.  
CLERK, ST. POLK CO.  
FLORIDA

and said grantor does hereby fully warrant the title to said land, and will defend the same against the lawful claims  
 of all persons whomsoever.  
 (Herein the terms "grantor" and "grantee" shall be construed to include masculine, feminine, singular, or plural as the context indicates.)

**In Witness Whereof,** Grantor has hereunto set grantor's hand and seal the day and year first above written.  
 Signed, sealed and delivered in our presence:

*Edith R. Conroy*  
 \_\_\_\_\_  
*[Signature]*  
 \_\_\_\_\_

*Betty Jane Bridges* (Seal)  
 Betty Jane Bridges  
*James Theodore Bridges* (Seal)  
 James Theodore Bridges  
 \_\_\_\_\_ (Seal)  
 \_\_\_\_\_ (Seal)

---

STATE OF FLORIDA  
 COUNTY OF POLK

I HEREBY CERTIFY that on this day before me, an officer duly qualified to take acknowledgments, personally  
 appeared **BETTY JANE BRIDGES and JAMES THEODORE BRIDGES, husband and wife,**  
 to me known to be the persons described in and who executed the foregoing instrument and acknowledged before  
 me that they executed the same.

WITNESS my hand and official seal in the County and State last aforesaid this 6th day of October  
 1961

My commission expires:

Notary Public, State of Florida at Large  
 My Commission Expires Jan. 5, 1965  
 Bonded by American Surety Co. of N. Y.

*[Signature]*  
 \_\_\_\_\_  
 Notary Public

**FILED, RECORDED AND  
 RECORD VERIFIED  
 D. H. SLOAN, JR., CLERK**

BY *R. J.*

30154

# Interpretation of Real Property Descriptions

FORM 1109 Florida Quit Claim Deed. 36089 TULSA REGISTERED & PAY OFFICE Tulsa Law Print Publishers, Tulsa, Okla.

## This Indenture

REC 652 PAGE 366

Wherever used herein, the term "party" shall include the heirs, personal representatives, successors and / or assigns of the respective parties herein; the use of the singular number shall include the plural, and the plural the singular; the use of any gender shall include all genders; and, if used, the term "and" shall include all the names herein described if more than one.

Made this 9<sup>th</sup> day of November A. D. 19 62  
 Between Thomas B. Harrison and wife, Georgia Dobson Harrison

Polk and State of Florida, of the County of  
 and Alna H. Willis, party of the first part,  
 H 12 11th ST, AUBURNDALE  
 Polk and State of Florida, of the County of

**Witnesseth**, that the said party of the first part, for and in consideration of the sum of other valuable considerations and TEN - - - - - Dollars, in hand paid by the said party of the second part, the receipt whereof is hereby acknowledged, has remised, released and quitclaimed, and by these presents does remise, release and quitclaim unto the said party of the second part all the right, title, interest claim and demand which the said party of the first part has in and to the following described lot, piece or parcel of land, situate lying and being in the County of Polk State of Florida, to wit:

An undivided one-half interest in and to the following described real property: Begin at the NE corner of the W $\frac{1}{2}$  of the NE $\frac{1}{4}$  of the NE $\frac{1}{4}$  of Section 34, Township 27 South, Range 25 East, run thence South 3 chains, 18 links, run thence West to the water's edge of Lake Arietta, run thence Northeasterly along the shore line of said Lake Arietta to the North line of Section 34, thence run East along the said section line to the point of beginning.

**To Have and to Hold** the same, together with all and singular the appurtenances thereunto belonging or in anywise appertaining, and all the estate, right, title, interest and claim whatsoever of the said party of the first part, either in law or equity, to the only proper use, benefit and behoof of the said party of the second part.

**In Witness Whereof**, the said party of the first part has hereunto set his hand and seal the day and year first above written.

Signed, Sealed and Delivered in Our Presence:

Otto C. Owen Jr. Thomas B. Harrison  
Dora Everett Georgia Dobson Harrison

FILED, RECORDED AND  
 RECORD VERIFIED  
 D. H. SLOAN JR. CLK. Cir. Ct.  
 POLK COUNTY, FLA

State of Florida,  
 County of Polk  
 I HEREBY CERTIFY, That on this day personally appeared before me, an officer duly authorized to administer oaths and take acknowledgments,  
 Thomas B. Harrison and wife, Georgia Dobson Harrison  
 to me well known to be the person<sup>s</sup> described in and who executed the foregoing instrument and they acknowledged before me that they executed the same freely and voluntarily for the purposes therein expressed.  
 WITNESS my hand and official seal at Auburndale  
 County of Polk and State of Florida, this 9<sup>th</sup>  
 day of November A. D. 19 62

Dora Everett  
 Notary Public, State of Florida at Large  
 My Commission Expires June 21, 1966  
 Issued by American Fire & Casualty Co.

36089





**ENGINEERING SCALE**

## Scales

Drawings are made to a certain scale, which represents the ratio between the actual item and a drawing of it. **Usually** the drawing is a **reduced scale** but in some cases it is enlarged beyond actual size in order to show details. One unit of measurement on the map – 1 inch or 1 centimeter- could represent 10,000 of the same units on the ground. This would be a 1:10,000 scaled map.

Scales are classified as either metric or English. The English is divided into architectural, **engineering**, and mechanical groups. The most commonly used scale in the construction, maintenance and reading of assessment maps is the engineer's twelve- inch long triangular scale. It is divided decimally into ten units per inch, 20 units per inch, 30 units per inch, 40 units per inch, 50 units per inch and 60 units per inch. These are commonly referred to as 10, 20, 30, 40, 50 or 60 scales.

To use any scale, lay the scale on a surface parallel to a line. Use a sharp pencil to mark all measurements before moving the scale. Your moving the scale for each measurement increases the likelihood of a cumulative error. Indicate the measurements with a sharp pencil. Do not draw against the machined increment of the scale, instead use a straight edge to draw your line.

## Interpretation of Real Property Descriptions

---

**On the next few pages you will find a series of lines with the scale noted.**

Determine the length of the following lines at the scale indicated:

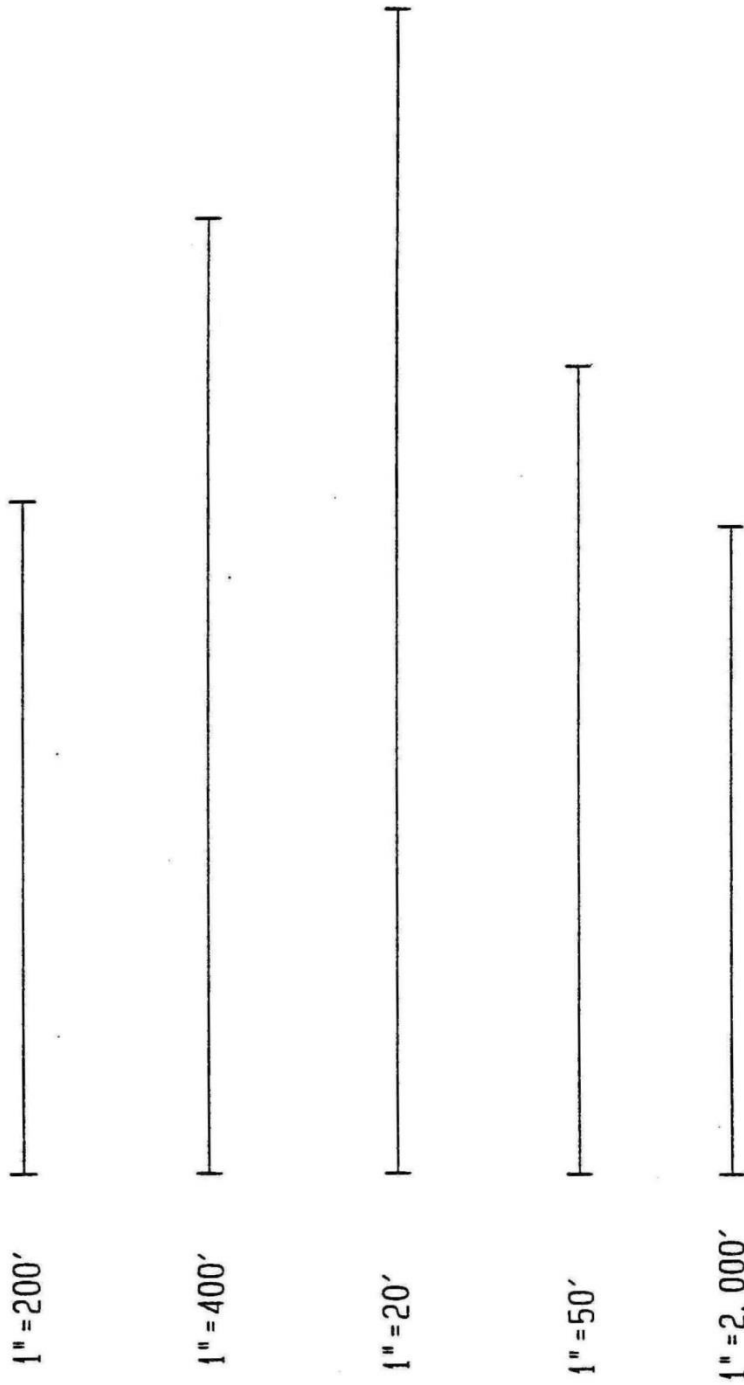

## Interpretation of Real Property Descriptions

---

Using your engineer's scale, give the distance for each line.

1. \_\_\_\_\_  
\_\_\_\_\_ ft.                      Scale 1" = 200'

2. \_\_\_\_\_  
\_\_\_\_\_ ft.                      Scale 1" = 300'

3. \_\_\_\_\_  
\_\_\_\_\_ ft.                      Scale 1" = 100'

4. \_\_\_\_\_  
\_\_\_\_\_ ft.                      Scale 1" = 400'

5. \_\_\_\_\_  
\_\_\_\_\_ ft.                      Scale 1" = 500'

6. \_\_\_\_\_  
\_\_\_\_\_ ft.                      Scale 1" = 600'

## Interpretation of Real Property Descriptions

---

7. \_\_\_\_\_  
\_\_\_\_\_ ft.                      Scale 1" = 400'

8. \_\_\_\_\_  
\_\_\_\_\_ ft.                      Scale 1" = 500'

9. \_\_\_\_\_  
\_\_\_\_\_ ft.                      Scale 1" = 200'

10. \_\_\_\_\_  
\_\_\_\_\_ ft.                      Scale 1" = 100'

**PROTRACTOR**

# Interpretation of Real Property Descriptions

---

## Protractor

The protractor is an instrument used to measure degrees in angle. It is either circular or semicircular (*like the one below*) and is divided into degrees and half degrees.

In the illustration of the semicircular protractor above, the center or zero degree crosshair is placed at the vertex of the angle, coinciding with the line to which the angle is referred. A mark is then made on the map or drawing at the proper graduation of the protractor arc. The protractor is removed, and a line is drawn joining this mark with the vertex.

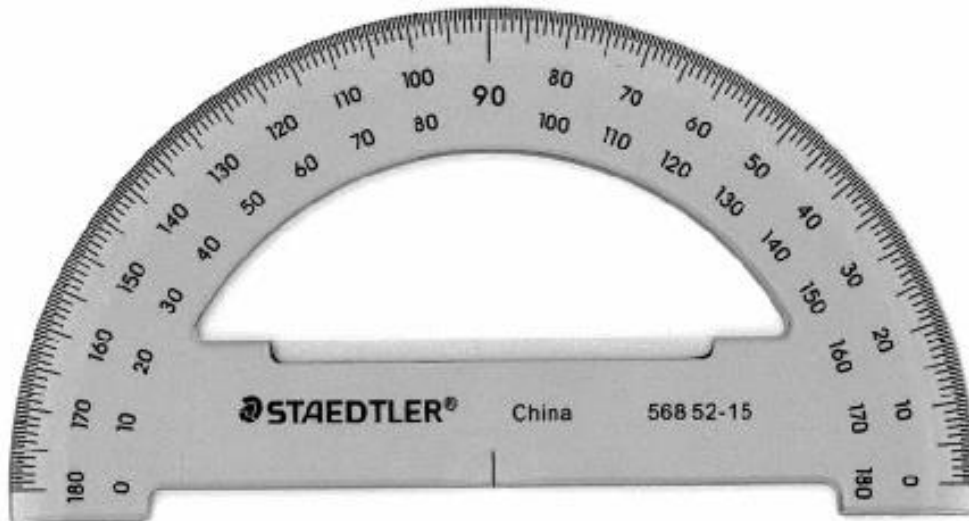

## Interpretation of Real Property Descriptions

---

Using your protractor, determine the angle on the figure below:

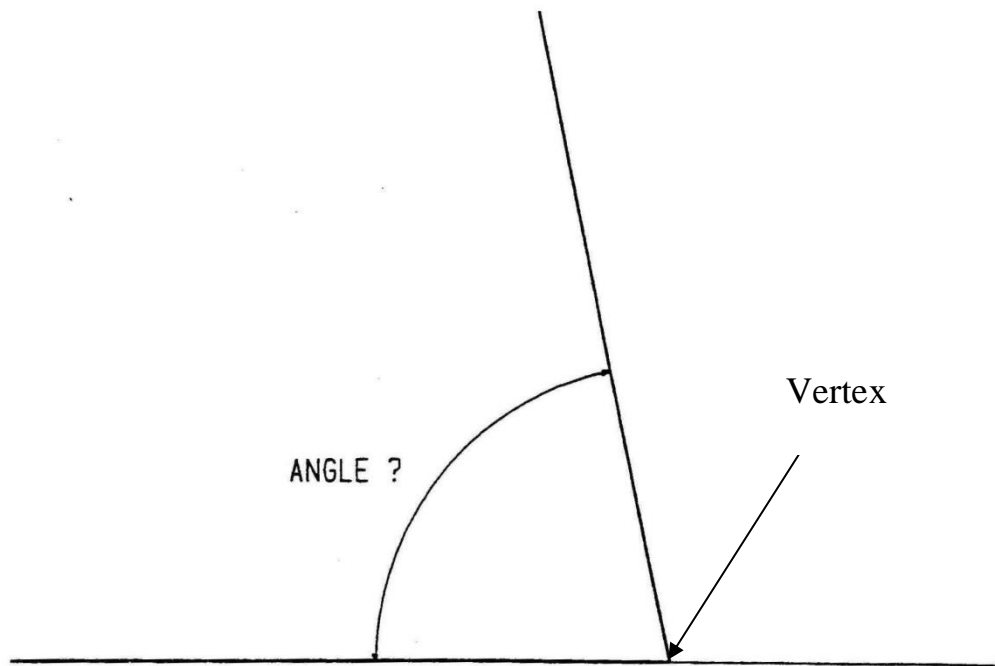



## Interpretation of Real Property Descriptions

---

Using your protractor, determine the angle on the figure below:

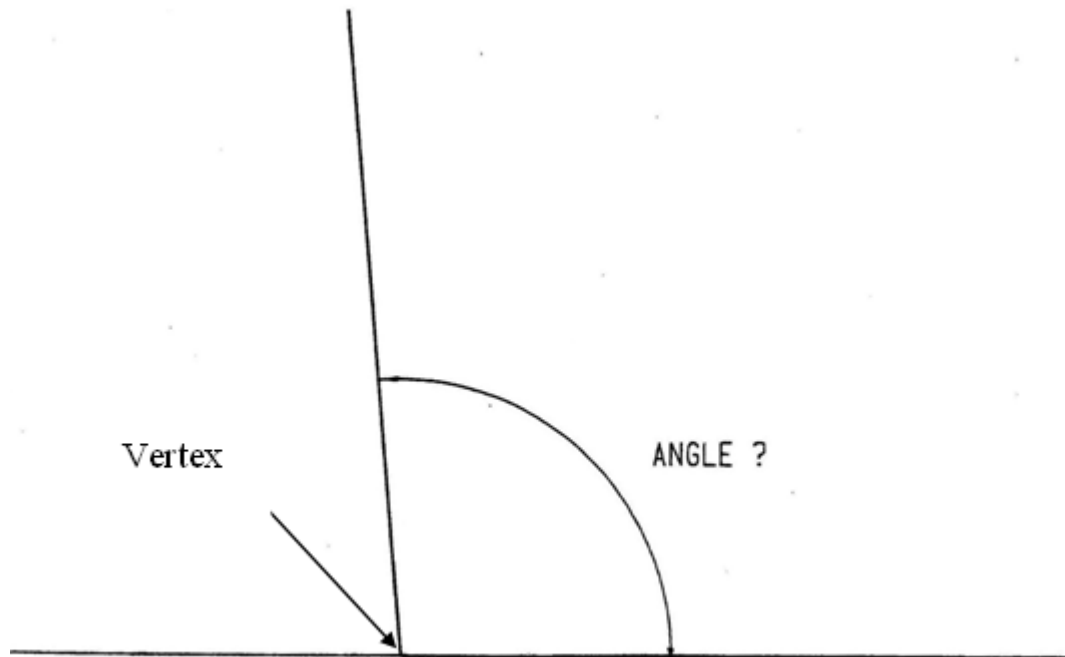

## Interpretation of Real Property Descriptions

---

Using your protractor, determine the angle on the figure below:

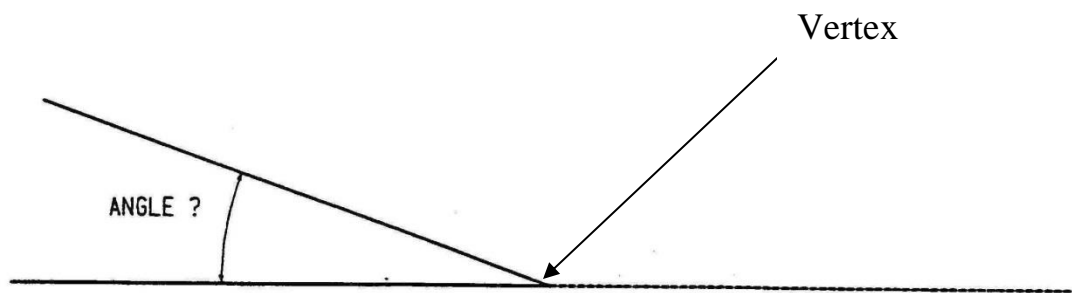

## Interpretation of Real Property Descriptions

---

Using your protractor, determine the angle on the figure below:

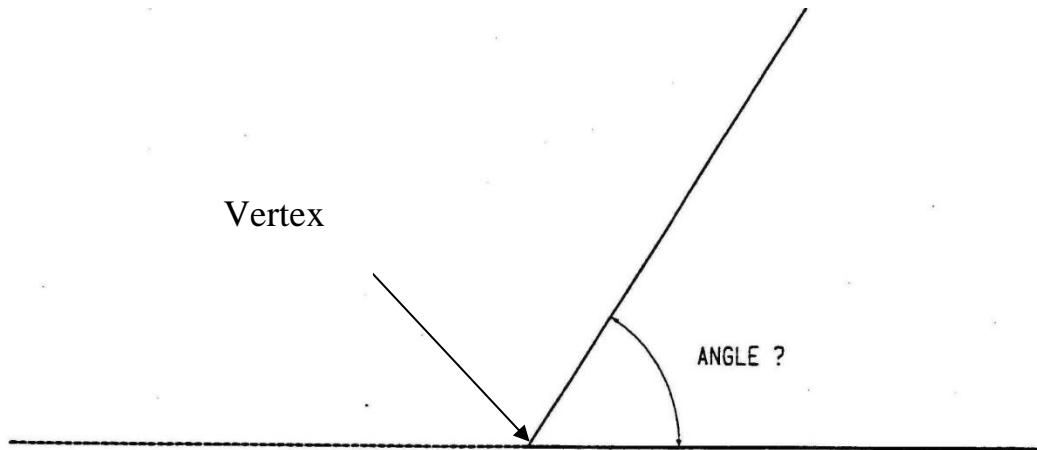

## BEARING & DISTANCES

*Putting it together*

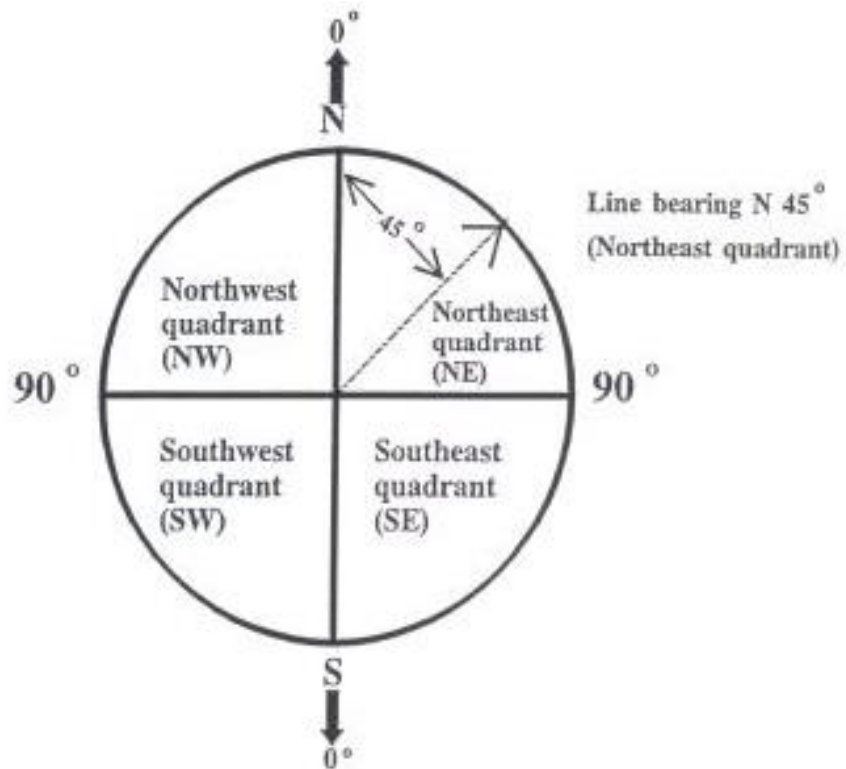

# Interpretation of Real Property Descriptions

The bearing of a line is the angle between the meridian and the line measured from either the north or south toward the east or west.

Bearings are expressed in **degrees, minutes, and seconds** (each **degree** is divided into **60 minutes**; each **minute** is divided into **60 seconds**) and may be written as:

N89deg52'30"W

A bearing will never exceed 90 deg and is always given from the north or south to the east or west.

**One degree = 60 minutes**

**One minute = 60 seconds**

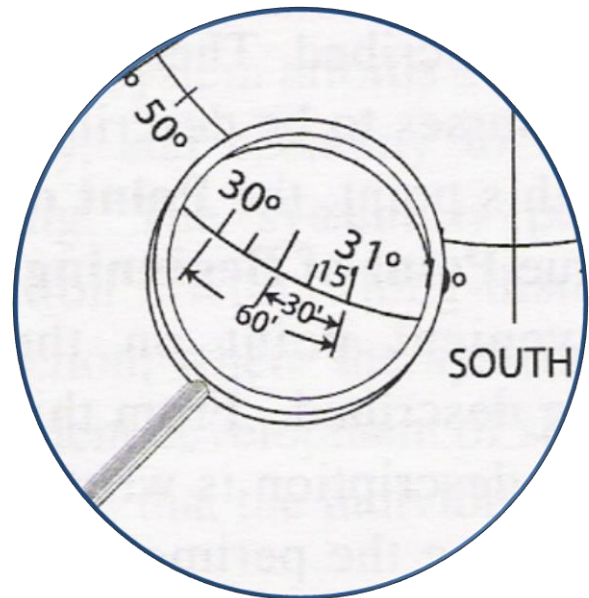
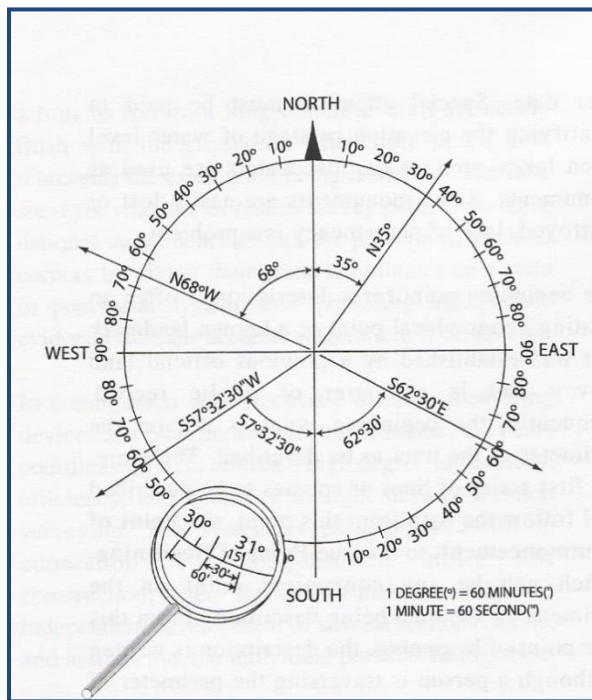

**LAND COMPASS**

*LAND COMPASS*



The Pronto Compass is constructed on the principle of the surveyor's compass; each quadrant of the circle is divided into 90 degrees.

# Interpretation of Real Property Descriptions

## To Lay Out a Description Using the Land Compass:

Beginning thence North 40 degrees East 200 feet,  
thence South 30 degrees East 250 feet,  
thence South 20 degrees West 150 feet,  
thence North 45 degrees West 290 feet,  
to the point of beginning.

Place the center of the compass at the point of beginning of the first line of the course, designated at Point A in FIGURE 1, with the North and South line of the compass coinciding with the line selected to be the North and South line of the map.

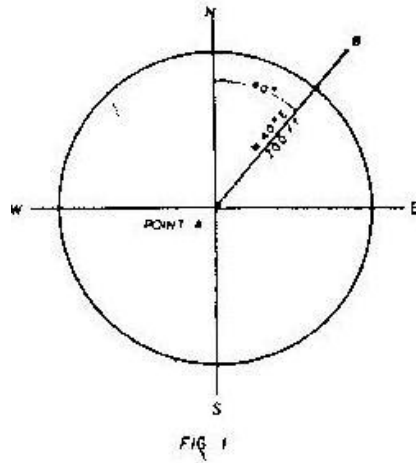

A “course” is the combination of the direction and length of any particular line, as ‘North 40 degrees East 200 feet,’ etc.

Then lay off 40 degrees from North toward East (see FIGURE 1), draw a line through this point.

With your scale measure off the first distance, which is 200 feet. This will fall at Point B.

Then move the center of the compass to Point B (see FIGURE 2) keeping the North and South line of the compass on a North and South line of the map. Repeat the process using the data in the second course. In the second course the bearing is South 30 degrees East; the angle to be laid off is 30 degrees from the South toward East, etc.

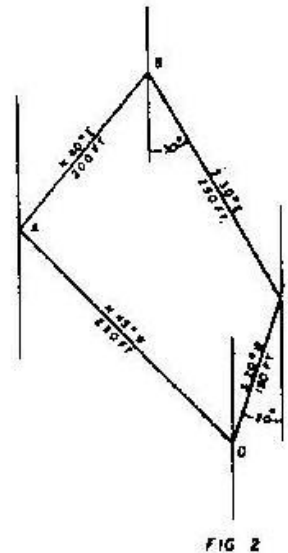

Proceed in the same manner throughout the balance of the description. When the last line ( in this case DA) is drawn it must pass through A and the distance from D to A must measure the distance given in the last course.

If the last two conditions are not fulfilled there is either an error in laying out the description, or the description is in error.

In the example given, the description proceeds clockwise. Had it been written so that it proceeded counter-clockwise, the dimensions would be the same but the directions would be reversed; that is, ‘North 45 degrees West’ would be South 45 degrees East; ‘South 20 degrees West’ would be North 20 degrees East etc.



## Interpretation of Real Property Descriptions

---

**Draw the bearing & distance from the information below on the map, start at the P.O.B.**

**Scale: 1"=10'**

N 00 deg E 10', N 90 deg E 10', S 00 deg W 10', S 90 deg W 10' to P.O.B.

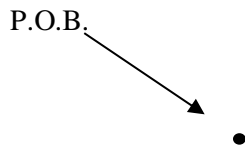

## Interpretation of Real Property Descriptions

---

**Draw the bearing & distance from the information below on the map, start at the P.O.B.**

**Scale: 1"=10'**

S 38 deg E 25', S 52 deg W 25', N 38 deg W 25', N 52 deg E 25', to P.O.B.

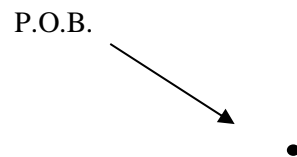

## Interpretation of Real Property Descriptions

---

**Draw the bearing & distance from the information below on the map, start at the P.O.B.**

**Scale: 1"=10'**

N 25 deg W 20', S 65 deg W 20', S 25 deg E 20', N 65 deg E 20', to P.O.B.

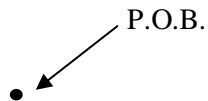

# Interpretation of Real Property Descriptions

---

This page intentionally left blank

# Interpretation of Real Property Descriptions

---

## Metes and Bounds Descriptions - Quiz

1. The walking and transfer of objects from the lands involved was called the action of \_\_\_\_\_.
2. The description that makes calls to adjacent land owners, trees, rocks, rivers, traveled ways, and so forth used to describe the perimeter of the property, is known as a \_\_\_\_\_.
3. The type of description used to describe land in the original thirteen colonies, Kentucky, Texas, West Virginia, Tennessee, Maine, Hawaii and parts of Ohio was the \_\_\_\_\_.
4. What is the type of description that will include a full heading and caption, recital of all ties and monuments, whether record or physical, **all** references to adjacent lands by name and record, and a full dimensional recital of the boundary courses in succession, and which must be mathematically correct.  
\_\_\_\_\_.
5. Items such as metal pipes, steel pins, or concrete posts are known as \_\_\_\_\_.
6. What must every metes and bounds description have in order to be valid?  
\_\_\_\_\_.
7. What is the part of a metes and bounds description that is normally used to ordinate the reader to the general area of the lands to be included with in the description and serves as a legal limit to the lands conveyed? \_\_\_\_\_.
8. A Gunter's chain is \_\_\_\_\_ links long and \_\_\_\_\_ feet in length.
9. If the basis of bearing was found on a survey it would be found in which part?  
\_\_\_\_\_.

## Interpretation of Real Property Descriptions

---

10. The portion of a metes and bounds description that gets the reader from the Point of Commencement to the Point of Beginning.  
\_\_\_\_\_
11. A Point of Commencement is necessary in every metes and bounds description.  
TRUE            FALSE
12. That portion of a metes and bounds description that generally contains all the various calls around the lands to be included within the description.  
\_\_\_\_\_
13. What is the angle between the meridian and the line measured from either the north or south toward the east or west called?  
\_\_\_\_\_
14. In the United States a bearing in a property description will *never* exceed 90°.   
TRUE            FALSE
15. A link in a Gunter's chain is equal to \_\_\_\_\_ inches.
16. A bearing is *always* given *from* the north or south *to* the east or west.  
TRUE            FALSE
17. Which type of angle is measured between a line and the prolongation of the preceding line?  
\_\_\_\_\_
18. The common unit of measurement in surveying boundaries in the 1800's was  
\_\_\_\_\_.
19. Angles to the left are measured \_\_\_\_\_ from the preceding line.
20. A survey based on a state plane coordinate system uses which type of meridian as the reference meridian? \_\_\_\_\_

# Interpretation of Real Property Descriptions

---

This page intentionally left blank

# Day 2

## CURVES



## CURVES

Besides their lengthy appearance, some feel that the most intimidating part of a metes and bounds description is the existence of a curve. But it should not be so. A curve is simply a part of the arc of a circle; the radius point being the center of the circle. The radius will radiate from the center of the circle to the edge of the circle.

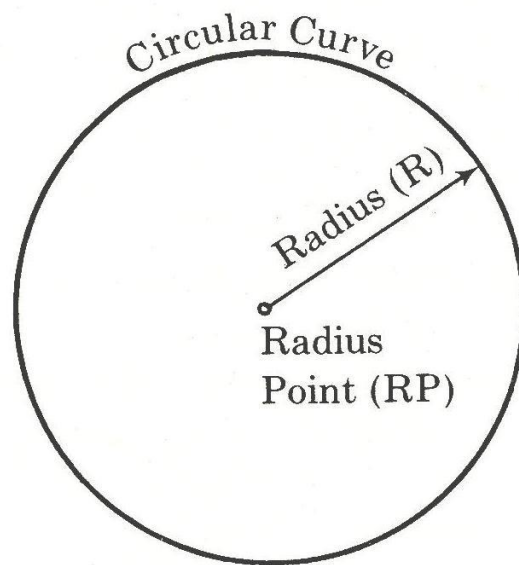

## **Definitions**

Radius is the distance from a point on the curve to the center of a circle.

Length of curve is the linear measurement of the curve.

Concavity is the inside or indented side of the curve. Conversely, the convex side of a curve is the outside or the side of the curve away from the center of the circle.

Direction upon a curve is the general bearing along the curve (such as northerly, southerly, southwesterly, etc.) Direction applied to concavity specifies the bearing from the concave curve at its midpoint to the center of the circle.

Tangency occurs when a curve is tangent to a course at a point if the radius of the curve at that point makes an angle of 90 with the course.

# Interpretation of Real Property Descriptions

## Circular Curve

The most frequently used curve in property descriptions is the *plane circular curve* which is simply a portion of the *arc of a circle* and can be plotted with a protractor and compass using the following:

The intersection of the tangents and the radii at the P.C. and P.T. are *always* right angles ( $90^\circ$ ).

The tangents are *always* of equal length.

The radii are *always* of equal length.

The intersection angle is *always* equal to the delta angle (a/k/a central angle).

The deflection angles between the tangents and the long chord are *always* equal to each other and are each one-half of the delta (central) angle.

The correlated parts, known as elements of a curve are as follows: *radius*, *arc length*, *central angle* (sometimes called *delta angle*), *semi-tangent* (usually described as *tangent*), and *chord*.

The figure below illustrates a circular curve and its elements.

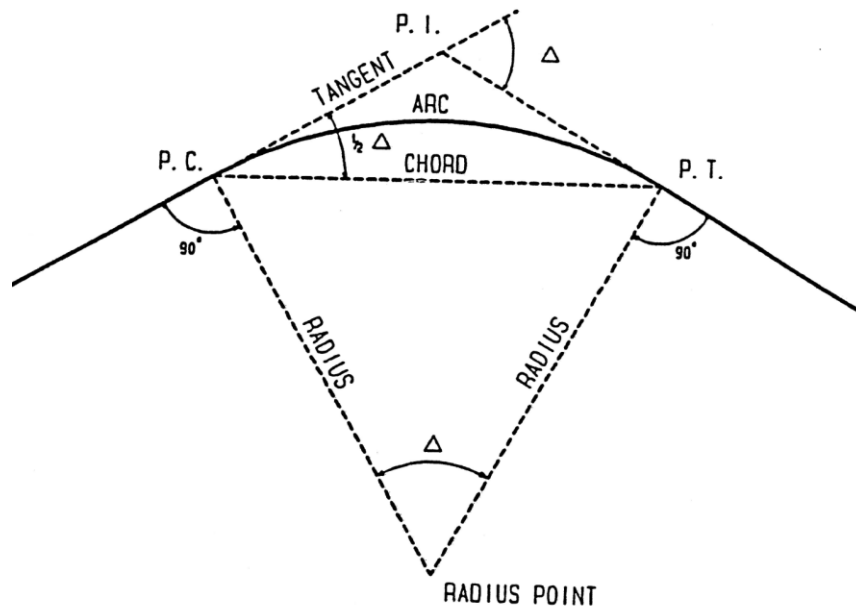

Most of the time, mathematically, a plane circular curve is fully determined by two of its elements; those most frequently used are the radius, length, tangent, delta (a/k/a central angle). In working with descriptions, surveyors tend to always provide the radius, central angle, and arc length. This provides three of the arc's elements to provide a check. Any other of the elements is a bonus allowing one to fully check the typing of the description.

## Five Elements Necessary to Plot a Curve

In description work, at least five elements are necessary to plot a curve:

1. & 2. At least two of the elements of the arc, preferably the radius and the central angle, from which all other mathematical elements may be determined;
3. The direction of curvature (“...concave to the Southeast”, “... curve to the right...”, or “...curve to the left...”. Convex is rarely used because it points away from the radius point;
4. The direction of travel (extension) along the curve (Ely; Sly); and
5. The relation of the curve to the preceding course or curve. It is assumed that all curves are tangent unless otherwise specifically noted as non-tangent or similar wording. The author may also include wording to assist the reader in understanding the relationship of the currently being described arc to any preceding or following arc (compound, reverse, or at a point of cusp) or line. See the figures on the following pages.

Optional additions to the five elements may include one or more of the dimension elements (tangent, chord bearing and/or length, etc.); relation of the curve to the next succeeding course or curve; and any other data for clarity or interpretation. Obviously, the additions must be precisely consistent with the necessary elements given. The more you have the more you can check the mathematics.



## Reverse Curve

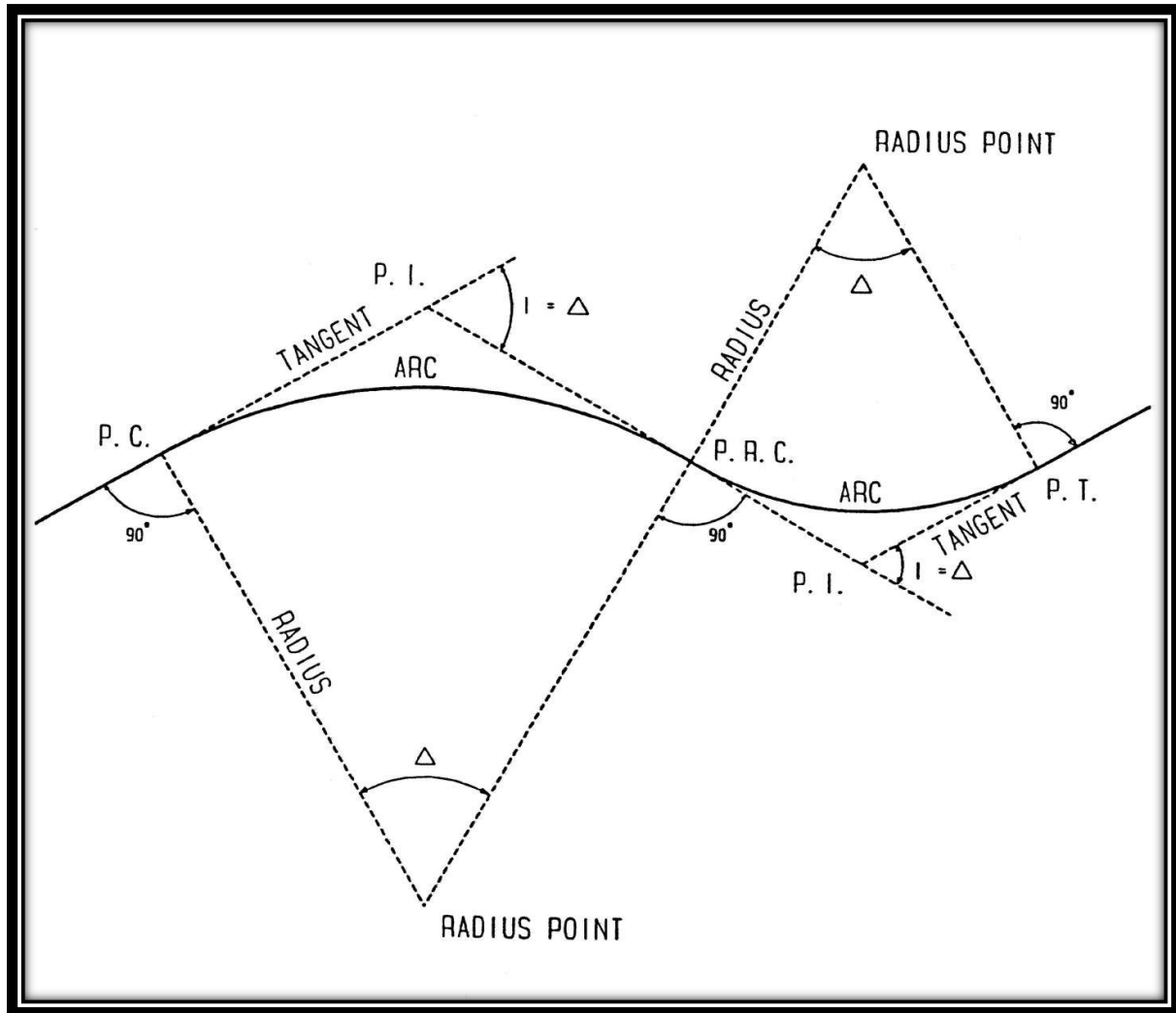

**Reverse curves** have a common radial line at the point of reverse and the centers of the circles are on opposite sides of the curve. The radial line of the adjoining curve is the prolongation of a radial line of the opposite curve.

## Spiral Curve

A spiral curve is a collective group of multiple compound curves having radii of successively decreasing or increasing lengths.

**Spiral curves** are generally used to provide a gradual change in curvature from a straight section of road or railroad to a curved section. They are sometimes called transition curves.

The figure below shows the placement of spiral curves in relation to circular curves.

Spiral curves are necessary on high-speed roads and railroads from the standpoint of comfortable operation and gradually bringing about the full superelevation of the curves.

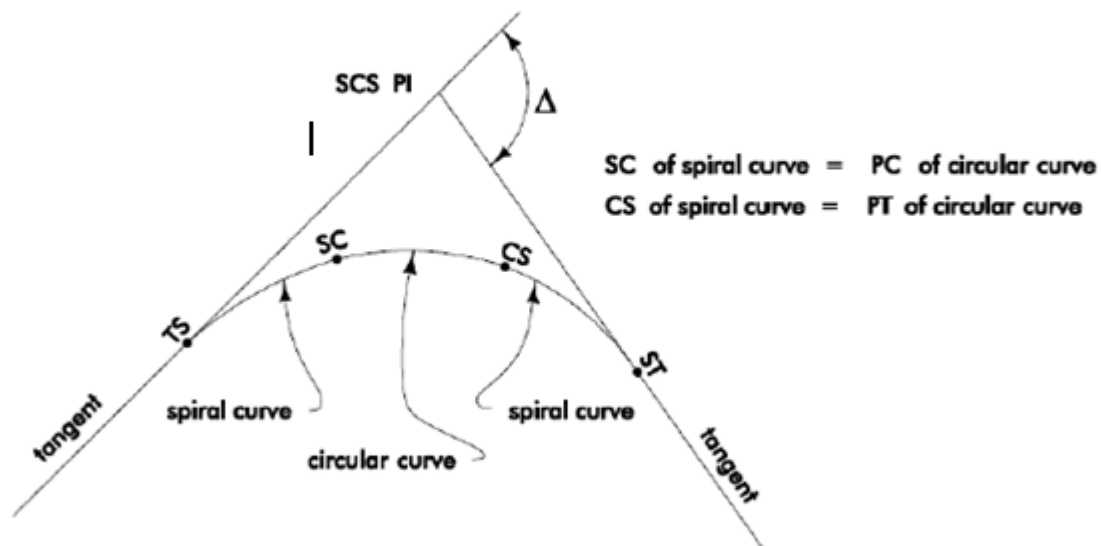

**Spiral Curve Abbreviations:**

SC: End of Spiral curve

TS: Beginning of Spiral curve

ST: End of Spiral Curve

CS: End of Circular Curve

**PLACEMENT OF A SPIRAL CURVE**

## Concavity or Convexity

The **concavity** (“...concave to the ...”) direction of a curve is that of the direction of the center of the circle of said curve from the mid-point of the arc described; a described segment of a record curve may be concave to the East, while the whole of the record curve may be concave to the North.

**Concavity** relates to the enclosed side of a curve toward the center of the circle. The general direction given for the concavity is that of the radial line from the midpoint of the arc toward the center.



**Convexity** relates to the outside face of a curve away from the center which is why it is seldom used.

The **direction** given along the curve is a general one (NE'ly, S'ly, etc.) for the total arc; however if the total angle is more than about 120°, two or more directions may be combined, such as W'ly and NW'ly.

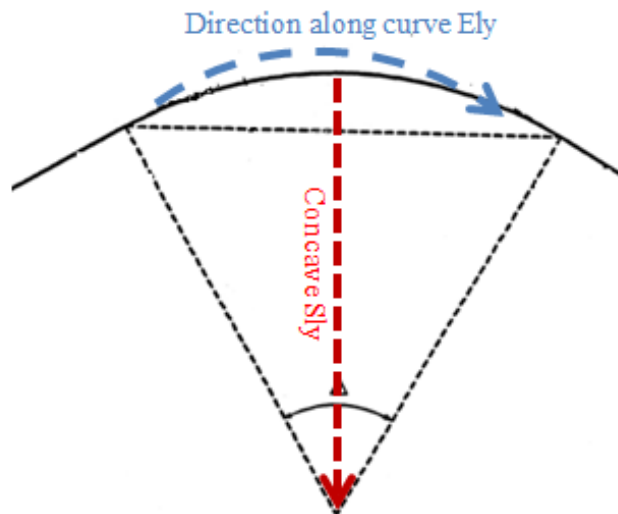

# Interpretation of Real Property Descriptions

## Radial Line

A radial line is a line drawn from a point on an arc to that arc's radius point.

Note: **Radial bearings** are furnished if a curve is not tangent to a course at the point of intersection thereof. The length and bearing of the radius must be given to determine the center of the circle.

## Non-tangent

Non-tangent relates to the fact that the point of curve is not tangent to the preceding line or curve. This is also known as a *broken-back curve*.

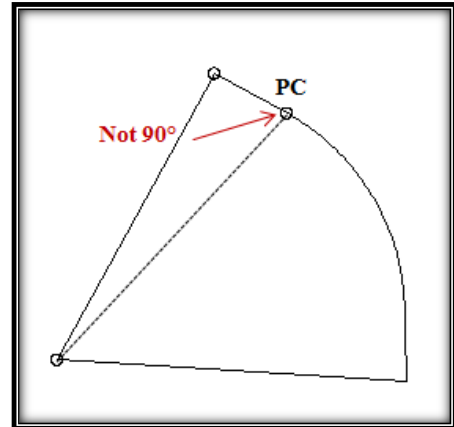

## Point of Cusp

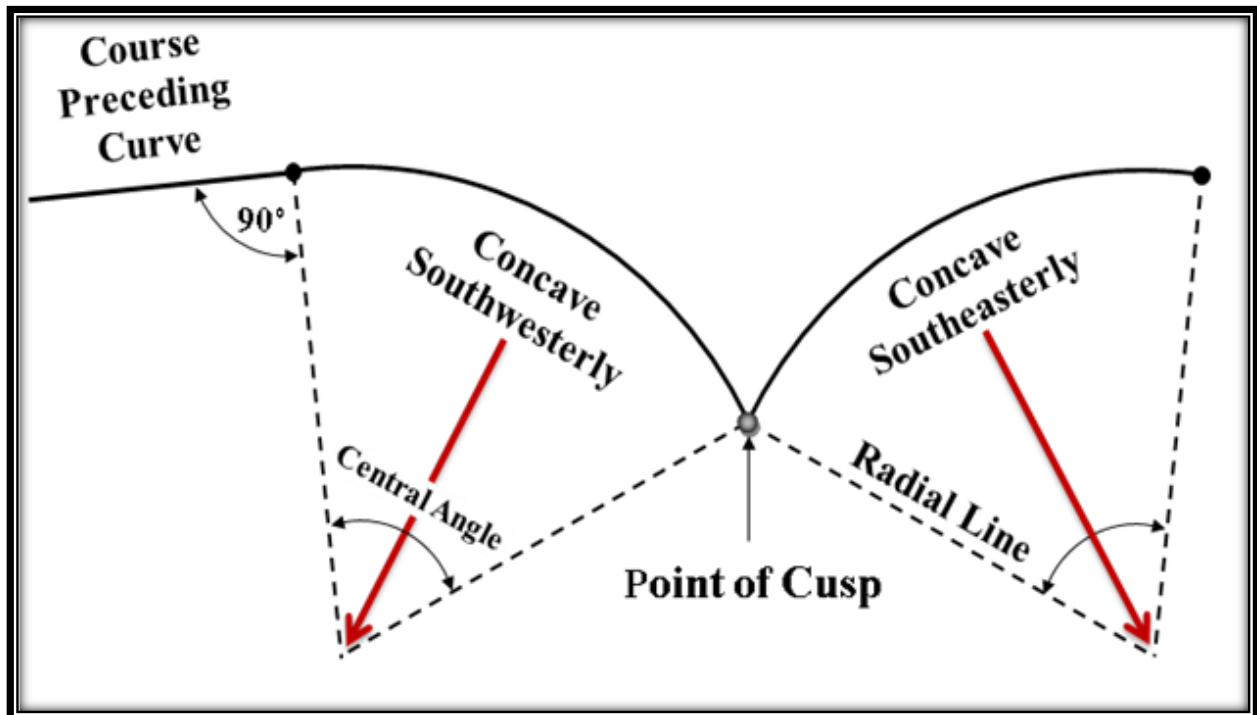

A *cusp* is the meeting of two curves or a curve and a straight line having the same general direction. The point of a crescent is a cusp.



Different Types of Curves and Parts of Curves

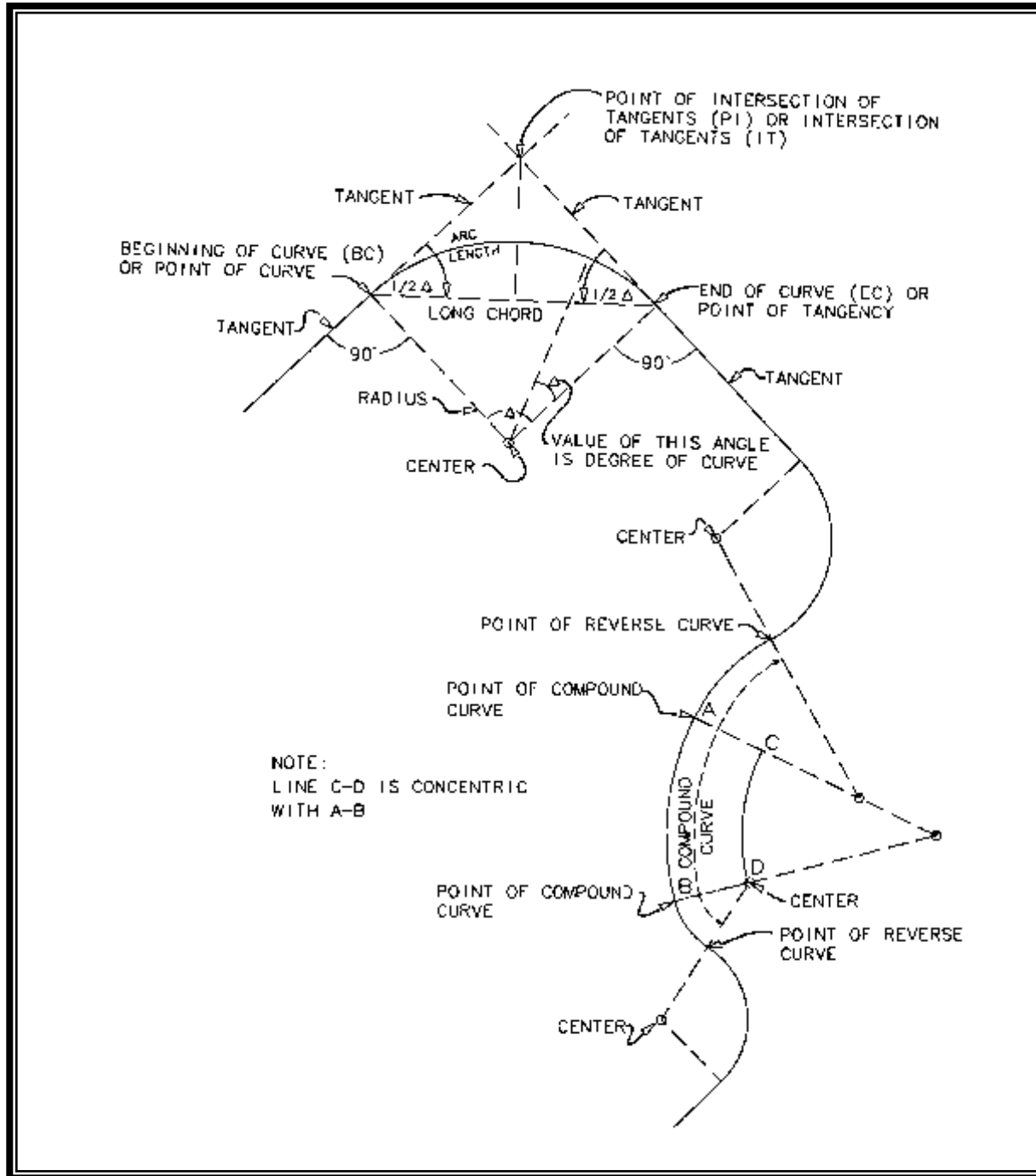

# Interpretation of Real Property Descriptions

---

## Abbreviations

The Board of Professional Surveyor and Mappers came up with the requirement that should the drawing reflecting the field survey contain a non-common abbreviation, the surveyor and mapper will place on that drawing an explanation of the abbreviation. The standard abbreviations are as follows:

N = North  
S = South  
E = East  
W = West  
or any combination such as NE, SW, etc.  
° = Degrees  
' = Minutes when used in a bearing  
" = Seconds when used in a bearing  
' = Feet when used in a distance  
" = Inches when used in a distance  
AC = Acres  
+/- = More or less (or Plus or Minus)  
metric notation

Any other abbreviations relating to survey matters must be clearly shown within a legend or notes appearing on the face of the map or report.

The following are somewhat standard abbreviations relating to curves that are used throughout Florida.

<u>Abbreviation</u>	<u>What it Means</u>	<u>What it is</u>
P.C.	Point of Curvature	- the beginning of the curve.
T	Tangent Distance	- each curve has two tangents, always of equal length.
P.I.	Point of Intersection	-the point where the tangents intersect.
I	Intersection Angle	-angle created between the continuations of the two tangents (angle at the P.I.). Sometimes called a Deflection Angle. Equal to the delta angle.
P.T.	Point of Tangency	- the point at the end of the arc for an arc that is tangent to the following course.
A	Arc (length)	- a length measured along the arc from the P.C. to the P.T.

## Interpretation of Real Property Descriptions

---

<u>Abbreviation</u>	<u>What it Means</u>	<u>What it is</u>
L.C.	Long Chord	- a straight line from the beginning of the curve (not necessarily the P.C.) to the end of the arc (not necessarily the P.T.). Quite often just called “chord”.
P.C.C.	Point of Compound Curve	- point at end of arc of one curve which is the point at which a second curve begins. Radius lengths of the two curves will be different lengths but share a common radial line.
P.R.C.	Point of Reverse Curve	-point at end of the arc of first curve where the curve reverses and changes direction; the radial line of the adjoining curve is the prolongation of the radial line of the opposite curve.
R	Radius	-one half the diameter of the “circle”; a straight line from the center of the “circle” (the radius point) to a point on the arc that is tangent at the point of arc intersection; the lines from the radius point to the P.C. or the P.T. The two radii are always of equal length.
$\Delta$	Delta Angle or Central Angle	-the angle formed by the intersection of the radii at the center of the “circle”; the delta angle is equal to the intersection angle at the P.I.
L.C.B.	Long Chord Bearing	-the bearing of the long chord.
D	Deflection Angle	-the angle between the tangents and the long chord; always equal to each other in the same curve; each is equal to 1/2 the delta angle.

## MAPPING STUDY EXERCISES - CURVES

**Draw the tangent and non-tangent curves using the below information.**

**Scale of 1" = 100'**

- 1) N 56 deg E, a distance of 66'; thence ne'ly along the arc of a non-tangent curve concave to the SE having a radius of 250' and a central angle of 57 deg (the radius point bearing S87 deg E from the arc beginning), a distance of 250'.
- 2) N 60 deg E, a distance of 293'; thence ne'ly and se'ly along the arc of a tangent curve concave to the SW having a radius of 220' and a central angle of 90 deg, a distance of 345'.
- 3) S 78 deg E, a distance of 82' to a point on a curve concave northwesterly, having a radius of 200' and whose radius point bears N 1 deg E; thence ne'ly along said curve through a central angle of 62 deg, a distance of 218'.
- 4) N 29 deg E, a distance of 143' to the point of curvature of a curve concave southeasterly, having a radius of 150'; thence ne'ly along said curve through a central angle of 73 deg, a distance of 192'.
- 5) N 88 deg W, a distance of 158' to a point on a curve concave easterly, having a radius of 451'; and whose radius bears N 79 deg E, thence northerly along said curve through a central angle of 12 deg, a distance of 97'.
- 6) S 30 deg E, a distance of 267'; thence se'ly and ne'ly along the arc of a tangent curve concave to the NE having a radius of 105' and a central angle of 60 deg, a distance of 110'.
- 7) N 26 deg W, a distance of 103' to the point of curvature of a curve concave to the east, having a radius of 200'; thence n'ly along said curve to the right through a central angle of 41 deg for 146' to a point of reverse curvature with a curve concave to the west, having a radius of 100'; thence n'ly along said curve to the left through a central angle of 36 deg for 63'.
- 8) S 88 deg E, a distance of 172' to a point on the arc of a non-tangent curve concave to the southeast, a radial line of said curve through said point having a bearing of S 72 deg E; thence ne'ly along the arc of said curve to the right, having a central angle of 7 deg and a radius of 333' for an arc distance of 43'.

## Interpretation of Real Property Descriptions

---

- 9) S 64 deg E, a distance of 110' to a point on the arc of a non-tangent curve concave to the southeast, a radial line of said curve through said point having a bearing of S 64 deg E; thence ne'ly along the arc of said curve, to the right, having a central angle of 17 deg and a radius of 278' for an arc distance of 88'.
- 10) S 47 deg E, a distance of 201' to a point on the arc of a curve concave to the southeast, a radial line of said curve through said point having a bearing of S 47 deg E, thence sw'ly and s'ly along the arc of said curve to the left, having a central angle of 40 deg and radius of 437' for an arc distance of 305'.
- 11) N 70 deg E, a distance of 104' to the point of curvature of a curve to the right, having a radius of 280', thence, se'ly along said curve, through a central angle of 86 deg, a distance of 420' to a point of reverse curvature of a curve concave ne'ly, having a radius of 200'; thence, se'ly, along said curve, through a central angle of 65 deg, a distance of 230'.

**12) Use a 1" = 200' scale for the following:**

N 89 deg W, a distance of 286' to a point of curvature of a tangent curve concave to the northeast, thence nw'ly along the arc of said curve to the right, having a central angle of 85 deg and a radius of 350' for an arc distance of 519' to a point of compound curvature of a curve concave to the east, thence northerly along the arc of said curve to the right, having a central angle of 23 deg and a radius of 668' for an arc distance of 276'.

## Curves - Quiz

1. The \_\_\_\_\_ is the distance from a point on the curve to the center of the circle.
2. The \_\_\_\_\_ is always equal to the delta angle in a tangent curve.
3. Which angle is equal to one-half of the delta angle?  
\_\_\_\_\_
4. How many elements of the arc of a curve are necessary in order to plot the curve?  
\_\_\_\_\_
5. A group of two or more segments of arcs that have a common radial line at the point of contact, have different lengths of radius, and the radius points are on the same side of the curves are called what type of curve?  
\_\_\_\_\_
6. A \_\_\_\_\_ is a collective group of multiple compound curves having radii of successively decreasing or increasing lengths.
7. \_\_\_\_\_ relates to the enclosed side of a curve toward the center of the circle.
8. A single segment of arc of a circle is called a \_\_\_\_\_.
9. The meeting of two curves or a curve and a straight line having the same general direction is called a cusp.    TRUE    FALSE
10. Concavity relates to the outside face of the curve.    TRUE    FALSE
11. What is the name of the angles between the tangent and the chord?  
\_\_\_\_\_
12. The intersection of the tangents and the radii at the P.C. and the P.T. are always  
\_\_\_\_\_.

## Interpretation of Real Property Descriptions

---

13. How many total elements are needed in order to plot a curve?

---

14. What does the abbreviation P.C.C. stand for?

---

15. What does the abbreviation P.R.C. stand for?

---

16. The concavity direction of a curve is that of the directions of the center of the circle of said curve from the \_\_\_\_\_ of the arc described.

17. A \_\_\_\_\_ is a line drawn from a point on an arc to the arc's radius point.

18. What is another term for a broken-back curve?

---

19. What is the term used for the center of a circle?

---

20. Name the five elements of a curve.

---

## Typical Curve

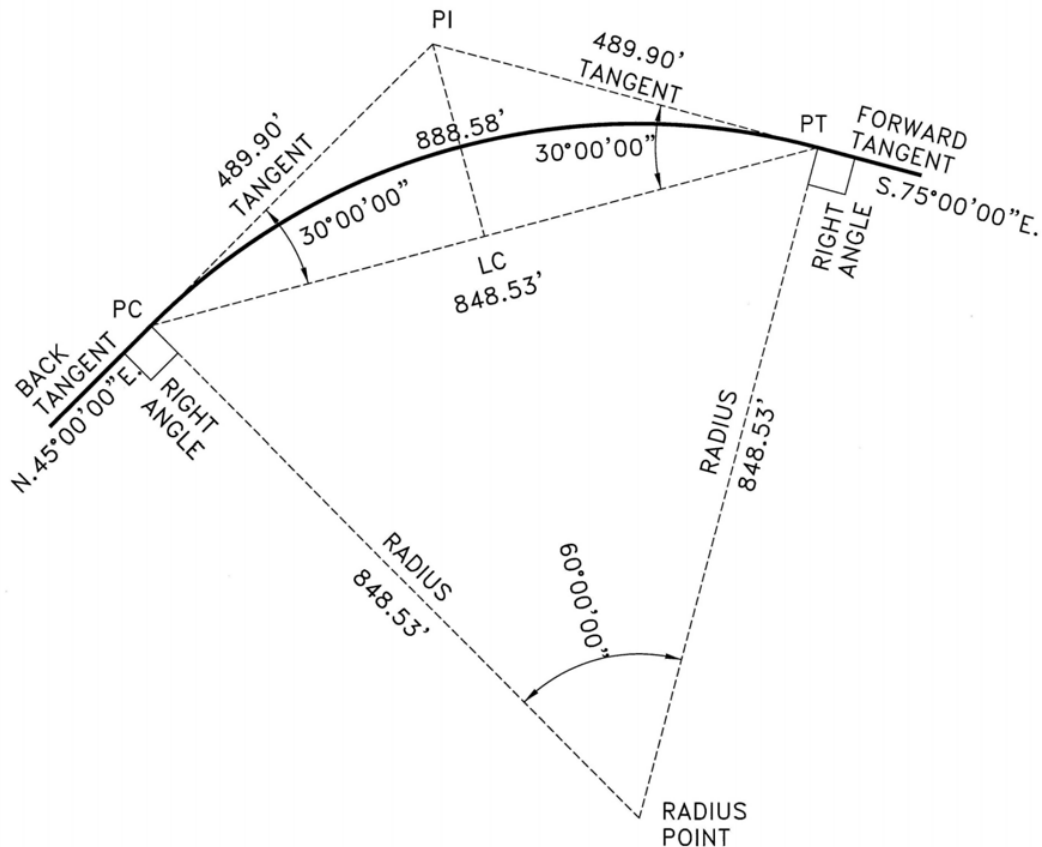

$R = 848.53'$  (radius)

$\Delta = 60^{\circ}00'00''$  (central angle)

$A = 888.58'$  (arc length)

$LC = 848.53'$  (long chord or chord)

Def  $\angle = 30^{\circ}00'00''$  (one-half of central angle)

$M = 131.68'$  (What does this mean? Where is this?)

$E = 131.27'$  (What does this mean? Where is this?)

$T = 489.90'$  (tangent)

BT (Back Tangent) =  $N.45^{\circ}00'00''E.$  (Where is this?)

FT (Forward Tangent) =  $S.75^{\circ}00'00''E.$  (Where is this?)



## Curve Exercises

1. Curve Exercise: Match the elements of the curve and write down the numbers that correspond

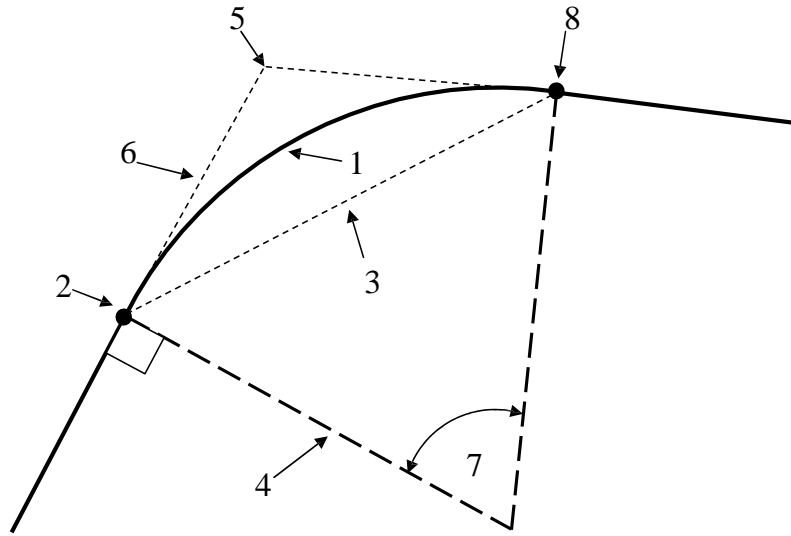

Radius = \_\_\_\_\_

Tangent = \_\_\_\_\_

PC = \_\_\_\_\_

PT = \_\_\_\_\_

Central Angle = \_\_\_\_\_

Arc Length = \_\_\_\_\_

PI = \_\_\_\_\_

Long Chord = \_\_\_\_\_

# Interpretation of Real Property Descriptions

## ARC DEFINITION CURVE

Radius (R): (The FIRST figured! Why?)

$$R = 5729.5788/D \text{ (formula)}$$

$$R = 5729.5788/10^{\circ}00'00'' \text{ (plug in the numbers)}$$

$$R = 5729.5788/10.000000 \text{ (convert to decimal degrees)}$$

$$R = 572.96' \text{ (multiply and get the answer)}$$

Tangent (T):

$$T = R * \tan (\frac{1}{2} \text{ central angle}) \text{ (the formula)}$$

$$T = 572.96 * \tan (42^{\circ}30'00''/2) \text{ (plug in the numbers)}$$

$$T = 572.96 * \tan 21^{\circ}15'00'' \text{ (central angle / 2)}$$

$$T = 572.96 * \tan 21.250000 \text{ (get the decimal delta)}$$

$$T = 572.96 * 0.388878732 \text{ (get the tangent figure)}$$

$$T = 222.81 \text{ (multiply and get answer)}$$

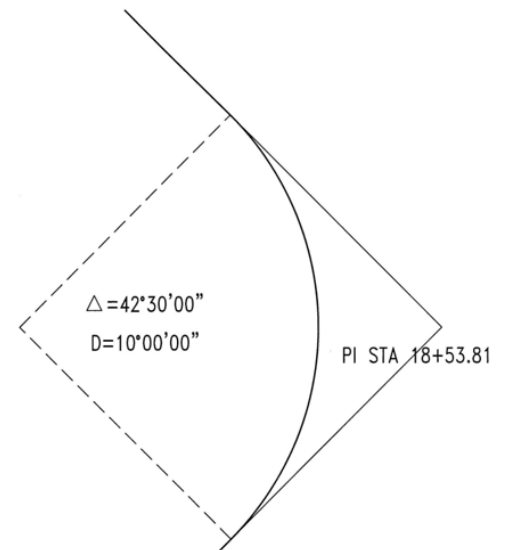

PC Station (PC): (For the PC Station, use the tangent.)

$$\text{PC Station} = \text{PI Station} - T \text{ (the formula)}$$

$$\text{PC Station} = 18+53.81 - 222.81 \text{ (plug in the numbers and subtract) PC}$$

$$\text{Station} = 16+31.00 \text{ (answer)}$$

Arc Length (A):

$$\text{Arc} = 100 * (\text{central angle}/D) \text{ or } \text{Arc} = (\text{central angle} * R * n) / 360 \text{ (the formula)}$$

$$\text{Arc} = 100 * (42^{\circ}30'00'' / 10^{\circ}00'00'') \text{ (plug in the numbers)}$$

$$\text{Arc} = 100 * (42.5/10.000000) \text{ (create decimal central angle and decimal degree of curve)}$$

$$\text{Arc} = 100 * 4.25 \text{ (divide right side first)}$$

$$\text{Arc} = 425.00' \text{ (multiply and get answer)}$$

PT Station (PT): (We do this after figuring the PC Station and Arc Length.)

$$\text{PT Station} = \text{PC Station} + \text{Arc} \text{ (formula)}$$

$$\text{PT Station} = 16+31.00 + 425.00 \text{ (plug in and add) PT Station} = 20+56.00 \text{ (answer)}$$

Deflection (Def):

$$\text{Def} = \text{central angle}/2 \text{ (formula)}$$

$$\text{Def} = 42^{\circ}30'00'' / 2 \text{ (plug in the numbers)}$$

$$\text{Def} = 42.5 / 2 \text{ (change to decimal degrees)}$$

$$\text{Def} = 21.25 \text{ (divide the decimal degrees)}$$

$$\text{Def} = 21^{\circ}15'00'' \text{ (convert back to degrees, minutes and seconds and get answer)}$$

# Interpretation of Real Property Descriptions

## Long Chord:

$$LC = 2R * \sin \frac{1}{2} \text{ central angle (formula)}$$

$$LC = (2 * 572.96) * \sin 42^\circ 30' 00" / 2 \text{ (plug in the numbers)}$$

$$LC = (2 * 572.96) * 0.362438038 \text{ (get sin of half central angle converted to decimal degrees)}$$

$$LC = 1145.92 * 0.362438038 \text{ (convert radius)}$$

$$LC = 415.32' \text{ (multiply and get answer)}$$

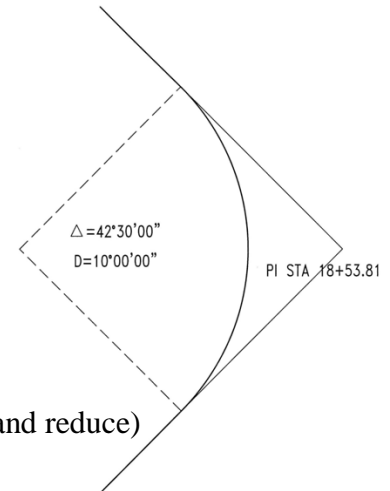

## Sector Area:

$$\text{Sector} = (\Delta / 360) * (nR^2) \text{ (the formula) or Sector} = (nR^2\Delta) / 360$$

$$\text{Sector} = (42^\circ 30' 00'' / 360) * (3.14159265 * 572.96^2) \text{ (plug in the numbers)}$$

$$\text{Sector} = (42.5 / 360) * (3.14159265 * 572.96^2) \text{ (convert to decimal degrees and reduce)}$$

$$\text{Sector} = (0.11805556) * (1,031,331.9688) \text{ (multiply overall)}$$

$$\text{Sector} = 121,754.4685 \text{ square feet (answer) or 121,754 square feet normally.}$$

## Segment Area:

$$\text{Segment} = \text{Sector} - \frac{R^2 \sin \Delta}{2} \text{ (the formula)}$$

$$\text{Segment} = 121,754.4685 - \frac{572.96^2 \sin 42^\circ 30' 00''}{2} \text{ (plug in numbers, see Sector)}$$

$$\text{Segment} = 121,754.4685 - \frac{328,283.1616 \sin 42.5^\circ}{2} \text{ (square and convert to decimal degrees)}$$

$$\text{Segment} = 121,754.4685 - \frac{328,283.1616 * 0.67559021}{2} \text{ (get the sin, divide and multiply)}$$

$$\text{Segment} = 121,754.4685 - 110,892.4447 \text{ (subtract overall)}$$

$$\text{Segment} = 10,862.0238 \text{ square feet (answer) or 10,862 square feet normally.}$$

## Fillet Area:

$$\text{Fillet} = R * T - (\Delta/360) * (nR^2) \text{ (the formula)}$$

$$\text{Fillet} = 572.96 * 222.81 - (121,754.4685) \text{ (plug in the numbers, see Sector)}$$

$$\text{Fillet} = 127,661.2176 - (121,754.4685) \text{ (multiply left)}$$

$$\text{Fillet} = 127,661.2176 - 121,754.4685 \text{ (subtract overall)}$$

$$\text{Fillet} = 5,906.7491 \text{ square feet (answer) or 5,907 square feet normally.}$$

Again, as you can see, the Sector Area is of primary importance. You must have its operations down pat before you can compute the remaining portions with any degree of confidence.

## 2. Curve Exercise: Arc definition:

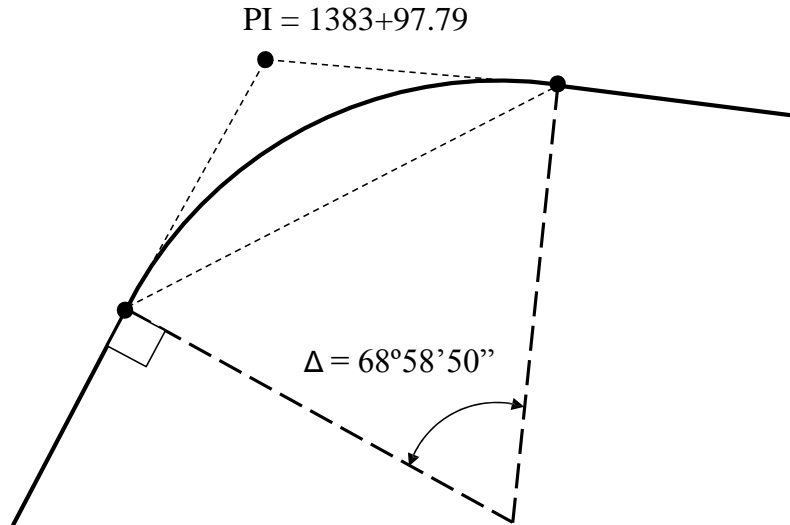

GIVEN:

Delta Angle =  $68^{\circ}58'50''$

Degree of Curve =  $02^{\circ}00'00''$

PI Station = 1383+97.79

Find:

Radius = \_\_\_\_\_

Tangent = \_\_\_\_\_

PC Station = \_\_\_\_\_

PT Station = \_\_\_\_\_

Arc Length = \_\_\_\_\_

Defection (Def) = \_\_\_\_\_

Long Chord = \_\_\_\_\_

## 3. Curve Exercise: Arc definition:

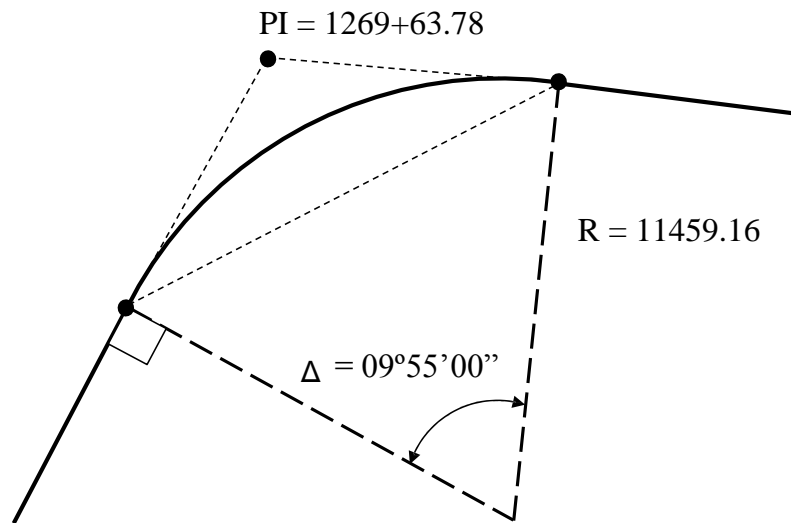

GIVEN:

Radius = 11459.16

Delta =  $09^{\circ}55'00''$

PI Station = 1269+63.78

Find:

Degree of Curve = \_\_\_\_\_

Arc Length = \_\_\_\_\_

Tangent = \_\_\_\_\_

Long Chord = \_\_\_\_\_

Sector Area = \_\_\_\_\_

PC Station = \_\_\_\_\_

PT Station = \_\_\_\_\_

## 4. Curve Exercise: Arc definition:

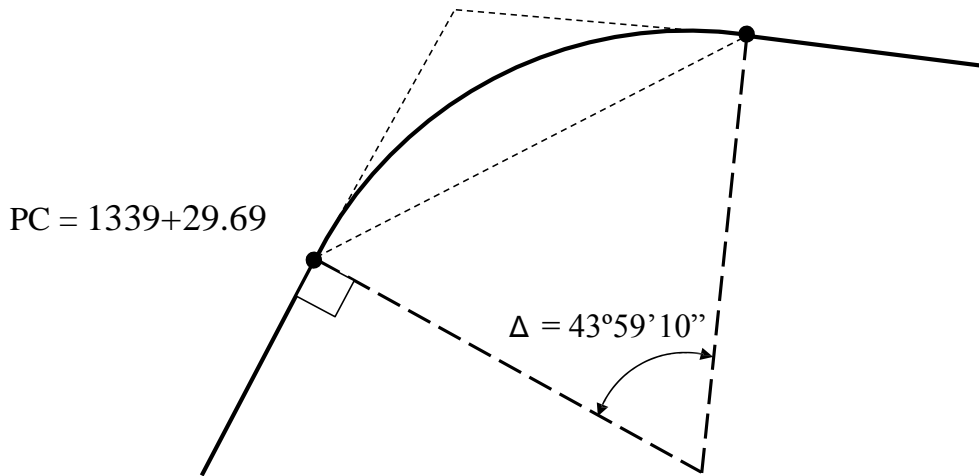

GIVEN:

Tangent = 771.36

Delta =  $43^{\circ}59'10''$

Tangent Bearing (Curve Right) = N03-20-34E

PC Station = 1339+29.69

Find:

Degree of Curve = \_\_\_\_\_

Arc Length = \_\_\_\_\_

Long Chord = \_\_\_\_\_

Radius = \_\_\_\_\_

Chord Bearing = \_\_\_\_\_

PT Station = \_\_\_\_\_

PI Station = \_\_\_\_\_

# Interpretation of Real Property Descriptions

---

## 5. Curve Exercise

Given:

Radius = 1145.92'

Delta = 20° 00' 00"

PI Station = 10+57.23

Find:

Degree of Curve = \_\_\_\_\_

Arc Length = \_\_\_\_\_

Tangent = \_\_\_\_\_

Long Chord = \_\_\_\_\_

Sector Area = \_\_\_\_\_

PC Station = \_\_\_\_\_

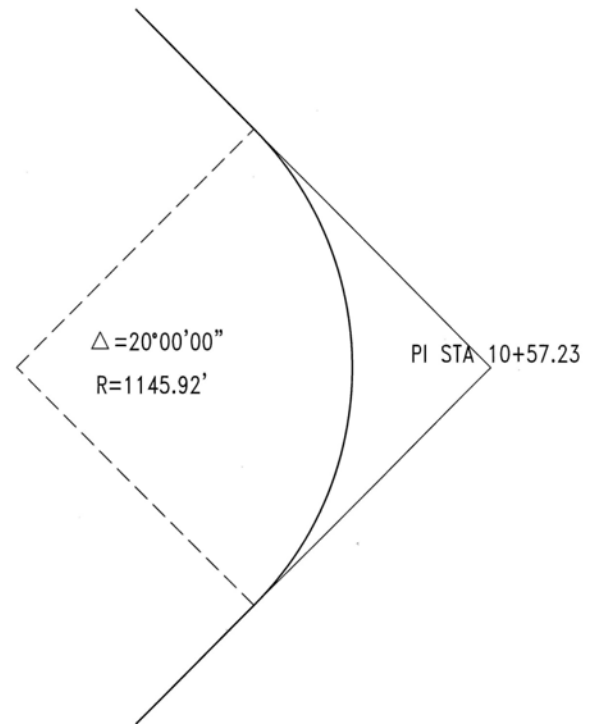

# Interpretation of Real Property Descriptions

---

## 6. Curve Exercise

Given:

Radius = 1243.33'

Delta = 46° 36' 25"

Find:

Degree of Curve = \_\_\_\_\_

Arc Length = \_\_\_\_\_

Tangent = \_\_\_\_\_

Long Chord = \_\_\_\_\_

Fillet Area = \_\_\_\_\_

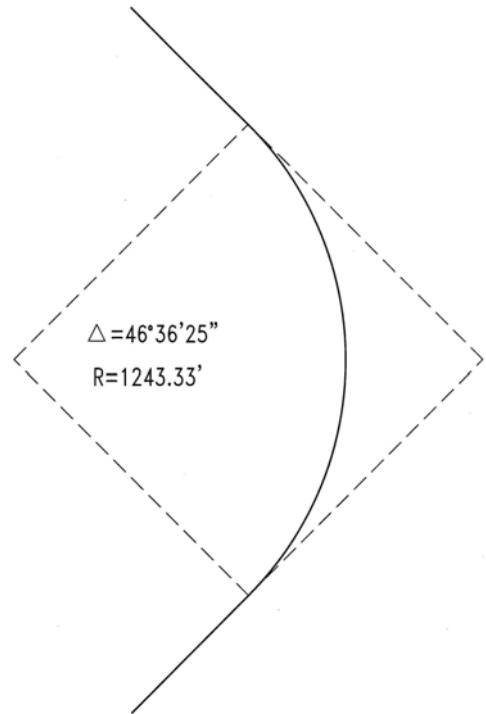



# Interpretation of Real Property Descriptions

---

## 7. Curve Exercise

Given:

Radius = 1109.32

Delta =  $65^{\circ} 25' 49''$

PI Station = 587+56.87

Find:

Degree of Curve = \_\_\_\_\_

Arc Length = \_\_\_\_\_

Tangent = \_\_\_\_\_

Long Chord = \_\_\_\_\_

Segment Area = \_\_\_\_\_

PT Station = \_\_\_\_\_

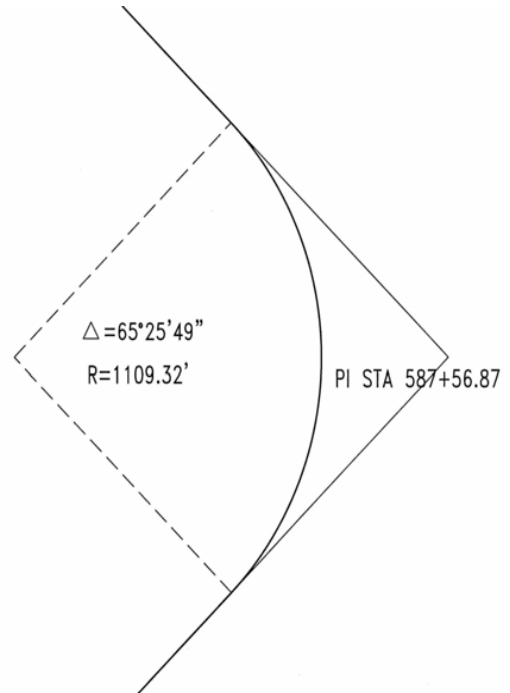

### Curve Exercises - Homework

#### Compound Curve Problem #1

Solve for all unknown curve elements and label all points on the sketch.

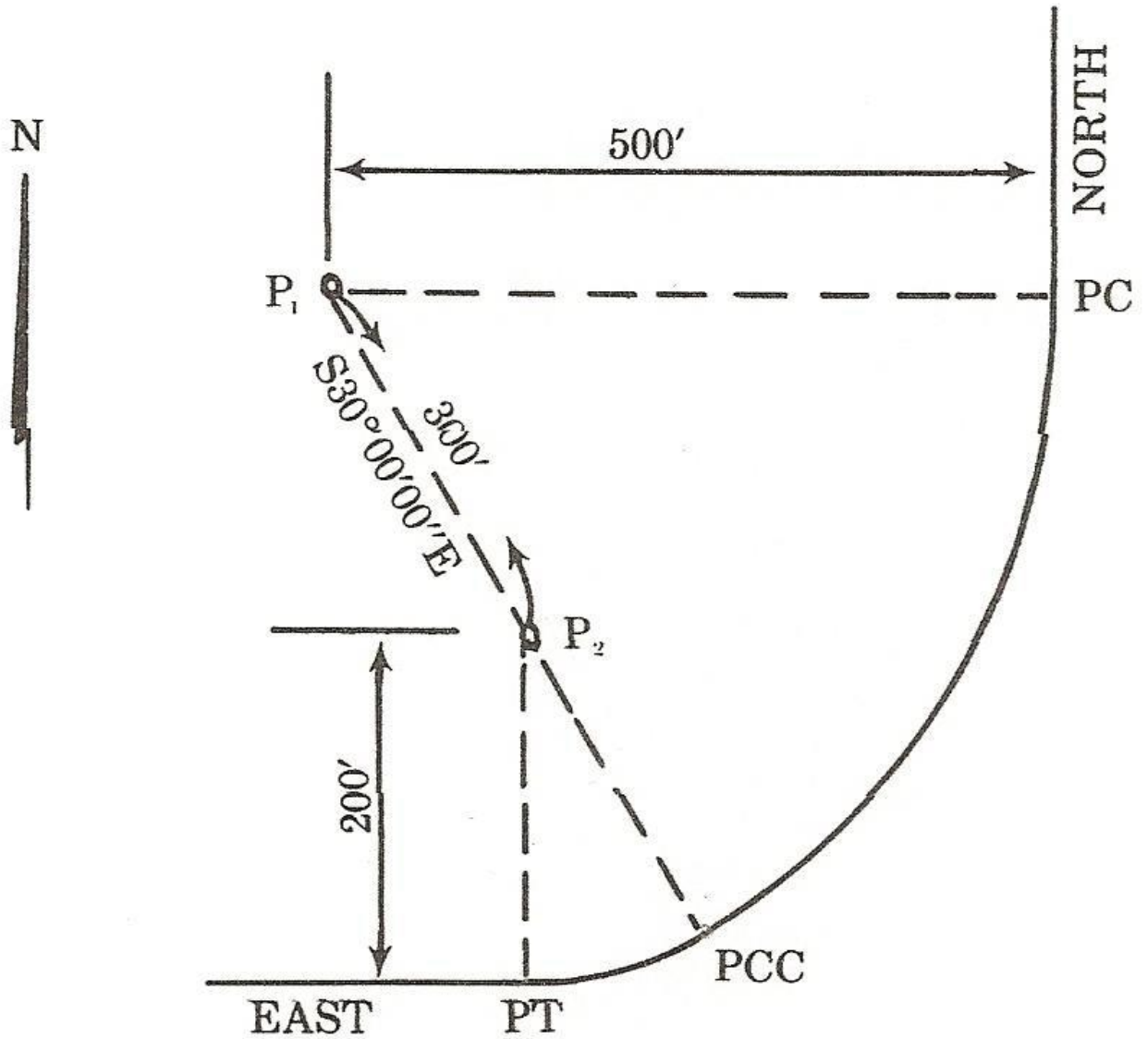

### Reverse Curve Problem #1

Solve for all unknown curve elements and label all points on this sketch.

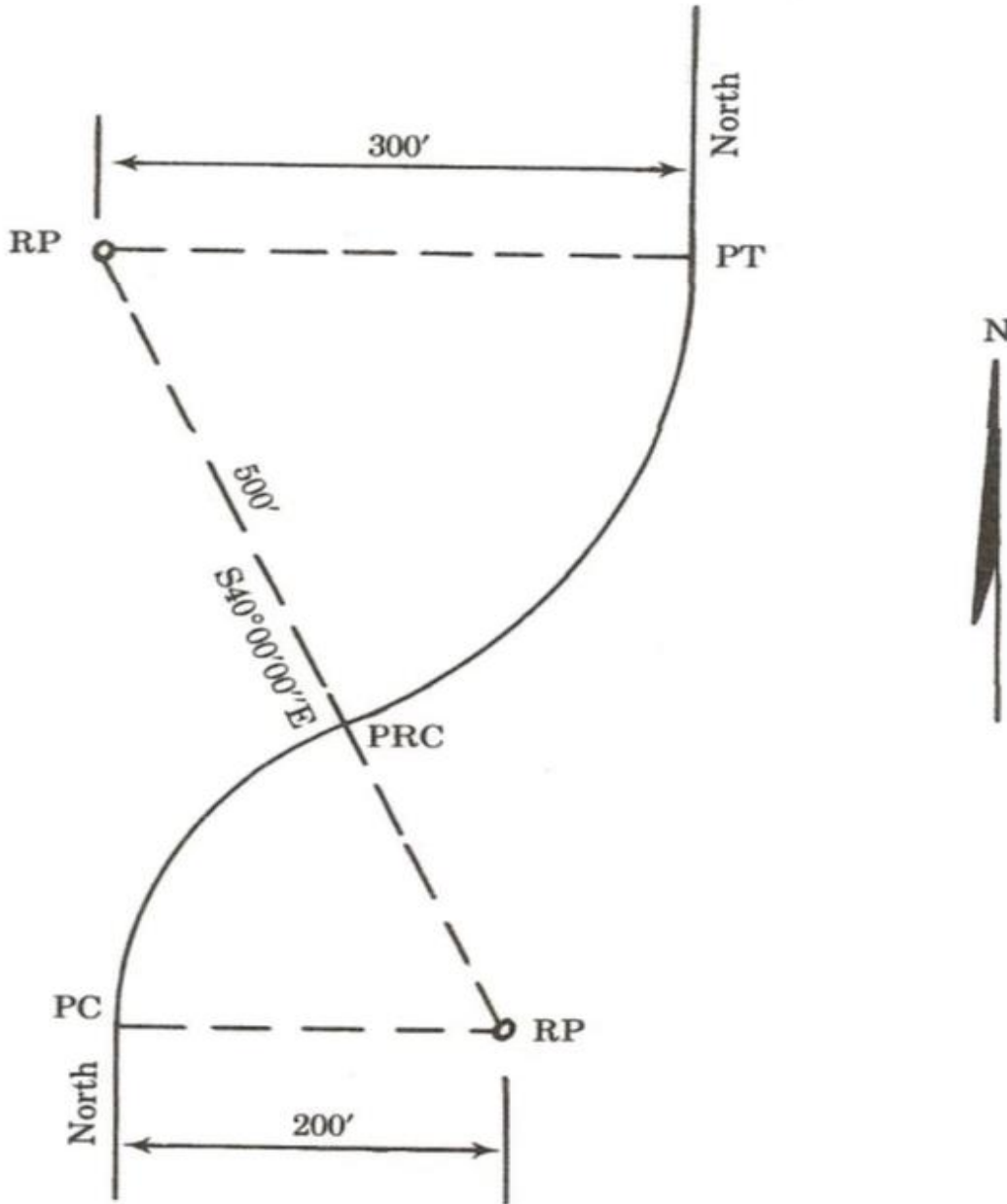

# **Day 3**

## **Subdivisions, Strip Descriptions, Stationing, Mapping in the Office of the Property Appraiser**

## **SUBDIVISION DESCRIPTIONS**

### **History of Subdivision Descriptions**

Subdivisions have been around since a person wanted to sell off a parcel of land that was smaller than what was bought originally and the perimeters of the parcel were determined by data on a graphical plan - a map or plat as some called it. The problem was after these lands were sold off, a few generations passed, or fires occurred, the plan became lost. Over time people forgot where their lands started and stopped, the perimeter among the then owners became obscured, and who had the best claim to a parcel became a feud in many cases.

To prevent the problems created by lost graphical plans and to prevent the King from having to pay for the upkeep of the roads, the King decided that the plan was to be recorded in a public accessible location before sales could occur. Then, only if and when the King agreed to maintain the roadways, would the King's Treasury be spent on such maintenance.

This also allowed the public access to a much shorter description than what was then available, which pleased everyone having to sell and buy land. In Florida, all this is now codified into [Chapter 177, Part I, Florida Statutes](#). Florida's plat law came into existence because in the early part of the Great Florida Land Boom of the late 1910's the plats being taken to the court house for recording were so poor than people couldn't find their lot, a large number of the drawings were not even being made by surveyor and mappers and the data on the drawing wouldn't "work." The legislators heard all the complaining and acted to create the first plat law, after which the quality greatly improved. At that point almost no one, other than a surveyor and mapper, filed a graphical plat.

Of course, the Plat Law as we shall refer to it from now on sets up certain minimum standards that a plat must meet. However, it doesn't have a thing to do with the perimeter survey of the lands to be included within a plat. The accuracy of the plat's perimeter is and always has been a preview of the [Minimum Technical Standards for Surveys in Florida](#) (also known as "Min Tech Standards" or "MTS"). The counties and cities can increase or add to those minimum plat requirements, but they can't reduce them.

Once a plat has been placed of record, it is called a "record plat". Its recording then allows people to refer to the designations shown on the plat to sell or purchase lands within that record plat and allows government to control the public dedicated lands (if any) shown on the plat. In fact, governments tend to use the platting process as a means to control what is happening within their jurisdiction.

# Interpretation of Real Property Descriptions

---

There are but few problems that arise from descriptions created solely from subdivision descriptions. We will discuss some of them below:

## **Splits and Merges of Florida's counties caused problems -**

The status of the perimeter of Florida's counties was changing while the platting processing was occurring. To start off with, when the United States took over control of the Florida's from the Spanish, General Andrew Jackson became Florida's Territorial Governor. He promptly created two counties which were really what the Spanish called West Florida and East Florida. Now we have sixty seven counties. So the counties have split, merged, and re-split until the county perimeters became somewhat stable in the early part of the Twentieth Century.

For example, Charlotte County was part of DeSoto County until 1921. DeSoto County was a part of Manatee County until 1886. Manatee County was a part of Alachua County in 1831. Luckily record plats were filed for Charlotte County only in Manatee and DeSoto Counties prior to Charlotte County being formed. As the counties split, the record plats were copied from one county to another, so Charlotte County is now using the third generation copy of the original.

This has created problems. There are several plats in Charlotte County which were not copied completely and have pieces of them missing and several which differ from the one recorded in Manatee County. Which plat would you use? The original document is the one the court's want accepted into evidence during a trial. But you use the advice of your legal consultant or legal staff.

## **Check the Plat Perimeter Description to the plat drawing**

When someone files a record plat, you sometimes have to make the split from an existing tract if the record plat does not cover the entire tract of land. Just make sure that the description on the plat covers the lands shown on the plat.

Sometimes the parcel's owner has the perimeter of the plat changed on the drawing but the changes are not made to the plat description. Always remember to verify the drawing is what is described in the plat description.

## **Dedication**

Besides the legal description of the perimeter of the plat, another main item on the plat that a cadastral mapper needs to pay specific attention to is the dedication. The dedication states the developer's plans for easements, drainage, streets, alleys, and conservation areas and are covered under [Florida Statute 177.081](#) shown below. The dedication will tell you whether the roads are private or dedicated to the public. Sometimes it will tell you what is dedicated to the homeowner's association. You should make sure to read it carefully.

# Interpretation of Real Property Descriptions

---

## **Basis of Bearing**

The basis of bearing is the bearing in degrees, minutes and seconds, or the equivalent, of a line between two monuments or corners which serves as a reference bearing for all other lines on the survey of the perimeter of the plat and should be shown on the plat.

## **F.S. 177.081 Dedication and Approval**

(1) Prior to approval by the appropriate governing body, the plat shall be reviewed for conformity to this chapter by a professional surveyor and mapper either employed by or under contract to the local governing body, the costs of which shall be borne by the legal entity offering the plat for recordation, and evidence of such review must be placed on such plat.

(2) Every plat of a subdivision filed for record must contain a dedication by the owner or owners of record. The dedication must be executed by all persons, corporations, or entities whose signature would be required to convey record fee simple title to the lands being dedicated in the same manner in which deeds are required to be executed. All mortgagees having a record interest in the lands subdivided shall execute, in the same manner in which deeds are required to be executed, either the dedication contained on the plat or a separate instrument joining in and ratifying the plat and all dedications and reservations thereon.

(3) When a tract or parcel of land has been subdivided and a plat thereof bearing the dedication executed by the owners of record and mortgagees having a record interest in the lands subdivided, and when the approval of the governing body has been secured and recorded in compliance with this part, all streets, alleys, easements, rights-of-way, and public areas shown on such plat, unless otherwise stated, shall be deemed to have been dedicated to the public for the uses and purposes thereon stated. However, nothing herein shall be construed as creating an obligation upon any governing body to perform any act of construction or maintenance within such dedicated areas except when the obligation is voluntarily assumed by the governing body.







## Interpretation of Real Property Descriptions

---

### Example – Plat Legal Description

Make sure to read the legal description carefully and make sure it matches the perimeter of the plat drawing.

#### LEGAL DESCRIPTION:

BEING A RESUBDIVISION OF THE SE 1/4 OF THE NE 1/4 OF THE SE 1/4 OF SECTION 14, TOWNSHIP 29 SOUTH, RANGE 24 EAST, AND/OR LOT 48 OF SAID SECTION 14 OF "W.F. HALLAM & CO.'S CLUB COLONY TRACT OF LAKE LAND HIGHLANDS FLORIDA SUBDIVISION," PLAT BOOK 1C, PAGES 102A AND 102B, PUBLIC RECORDS OF POLK COUNTY, FLORIDA;

AND

THE NE 1/4 OF THE SE 1/4 OF THE SE 1/4 OF SECTION 14, TOWNSHIP 29 SOUTH, RANGE 24 EAST, POLK COUNTY FLORIDA;

AND

THE SOUTH 280.00 FEET OF THE NORTH 1059.91 FEET OF THE NW 1/4 OF THE SW 1/4 OF SECTION 13, TOWNSHIP 29 SOUTH, RANGE 24 EAST, POLK COUNTY FLORIDA LYING WESTERLY OF THE ROAD RIGHT OF WAY FOR U.S. HIGHWAY 98.

CONTAINING 21.95 ACRES

# Interpretation of Real Property Descriptions

---

## Example – Plat Dedication

Make sure to read the dedication on the plat carefully and make note of whether roads are dedicated to the public or are private. Note if the dedication states if certain tracts are “common areas” and dedicated to the homeowners associations.

### DEDICATION:

STATE OF FLORIDA,  
COUNTY OF POLK

KNOW ALL MEN BY THESE PRESENTS THAT PREVUE HOMES, INC., A FLORIDA CORPORATION, OWNER OF THE LANDS SHOWN HEREON HAS CAUSED THIS PLAT OF "HILLSIDE HEIGHTS" TO BE MADE AND DOES HEREBY DEDICATE TO THE USE BY THE PUBLIC FOREVER ALL STREETS, ROAD RIGHTS OF WAY AND EASEMENTS SHOWN ON THIS PLAT FOR THE PURPOSES INDICATED.

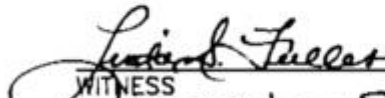
  
WITNESS  
PRINTED NAME: LINDA S. FULLER

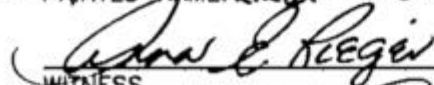
  
WITNESS  
PRINTED NAME: ANNA E. REEGEN

PREVUE HOMES, INC.  
A FLORIDA CORPORATION

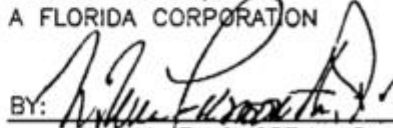
BY:   
W. WM. ELLSWORTH, JR.  
PRESIDENT

# Interpretation of Real Property Descriptions

---

## Example – Plat Surveyors Notes

The Surveyors Notes on the plat also will give you useful information. In this plat the notes state that the property owners are responsible for maintenance of vegetation in the retention areas and drainage swales and the design is to be left unchanged. In this specific subdivision there was an owner filling in an area of the drainage swales on his lot and planting shrubs and flowers and based on this note he was required to remove them. These notes also state what “Tract A” is to be used for and who maintains it. In this case the developer maintained it until he assigned it in a deed to the homeowner’s association.

### SURVEYORS NOTES:

- UNLESS OTHERWISE NOTED A 5/8" IRON ROD AND CAP "LB-7001" MONUMENTATION SET AT ALL LOT CORNERS, POINTS OF INTERSECTION, AND CHANGES OF DIRECTION OF LINE WITHIN THE SUBDIVISION WHICH DO NOT REQUIRE A PRM OR PCP.
- THIS PLAT IS BASED ON A RECENT SURVEY MADE UNDER MY DIRECTION AND SUPERVISION IN COMPLIANCE WITH CHAPTER 177, FLORIDA STATUTES.
- P.C.P.'S SET IN AN IMPERVIOUS SURFACE ARE A P.K.-NAIL AND DISC "LB-7001" – UNLESS OTHERWISE NOTED
- LANDS IN THE VICINITY OF THE DRAINAGE/RETENTION AREAS AND SWALES MAY BE SUBJECT TO TEMPORARY STANDING WATER WHEN CONDITIONS DECREASE THE RATE OF PERCOLATION AND DRAINAGE RUNOFF.
- PROPERTY OWNERS ARE RESPONSIBLE FOR MAINTENANCE OF VEGETATION IN THE RETENTION AREAS AND DRAINAGE SWALES AND THE DESIGN IS TO BE LEFT UNCHANGED.
- ALL PUBLIC UTILITY EASEMENTS SHALL ALSO BE EASEMENTS FOR THE CONSTRUCTION, INSTALLATION, MAINTENANCE, AND OPERATION OF CABLE TELEVISION SERVICES IN ACCORDANCE WITH FLORIDA STATUTE 177.091 (28).

### TRACT USAGE TABLE

- TRACT A IS A DRAINAGE/RETENTION AREA AND OPEN SPACE AREA TO BE MAINTAINED BY PREVUE HOMES, INC., OR ITS ASSIGNS.

# Interpretation of Real Property Descriptions

---

Again, notes made by the surveyor on the plat tell you the abbreviations used on the plat as well as the basis of bearing.

## NOTES:

- ▲ FOUND POINT AS NOTED
- PCP – PERMANENT CONTROL POINT – SET  
NAIL AND DISK "PCP LB-7001" – UNLESS OTHERWISE NOTED
- PRM – PERMANENT REFERENCE MONUMENT – SET  
4" X 4" CONCRETE MONUMENT AND CAP "PRM LB-7001"
- ▣ FCM – PERMANENT REFERENCE MONUMENT – FOUND  
4" X 4" CONCRETE MONUMENT "AS NOTED"
- ⊙ SIR SET 5/8" IRON ROD AND CAP "LB 7001"

BEARINGS ARE BASED ON THE WESTERLY BOUNDARY LINE OF THE SE 1/4 OF THE NE 1/4 OF THE SE 1/4 OF SECTION 14, BEING AS N 00°00'00" E, (ASSUMED) BETWEEN FOUND FIELD MONUMENTATION.

⑫ = CURVE – SEE CURVE DATA

#. NO.	= NUMBER	R	= RADIUS
&	= AND	△	= CENTRAL ANGLE/DELTA
℄	= CENTERLINE	L	= LENGTH
(RAD)	= RADIAL	T	= TANGENT
(NR)	= NON-RADIAL	C	= CHORD
PB	= PLAT BOOK	CB	= CHORD BEARING
PG/PGS	= PAGE/PAGES	O.R.	= OFFICIAL RECORDS OF POLK COUNTY, FLORIDA
(CALC)	= CALCULATED INFORMATION	EXIST	= EXISTING
(P)	= PLATTED INFORMATION	FIR	= FOUND IRON ROD – AS NOTED
(F)	= FIELD INFORMATION – AS MEASURED BETWEEN FOUND MONUMENTATION	FDOT	= FLORIDA DEPARTMENT OF TRANSPORTATION
U.S.	= UNITED STATES	PRC	= POINT OF REVERSE CURVE
R/W	= RIGHT OF WAY	STA	= STATION
		PT	= POINT OF TANGENT

## Interpretation of Real Property Descriptions

---

### Example – Special Notes on Plat

Other notes on the plat state the restriction that the property cannot be divided again unless replatted with the county. The last note states that the developer is responsible for maintenance of common areas until the homeowners association is created and then made responsible. The common areas were later conveyed by deed.

#### NOTICE:

THIS PLAT, AS RECORDED IN ITS GRAPHIC FORM, IS THE OFFICIAL DEPICTION OF THE SUBDIVIDED LANDS DESCRIBED HEREIN AND WILL IN NO CIRCUMSTANCES BE SUPPLANTED IN AUTHORITY BY ANY OTHER GRAPHIC OR DIGITAL FORM OF THE PLAT.  
THERE MAY BE ADDITIONAL RESTRICTIONS THAT ARE NOT RECORDED ON THIS PLAT THAT MAY BE FOUND IN THE PUBLIC RECORDS OF THIS COUNTY.

#### RESTRICTION ON FUTURE SUBDIVISION

NO FURTHER DIVISION OF THIS PROPERTY WILL BE PERMITTED BY POLK COUNTY UNLESS THE PROPERTY IS PLATTED IN ACCORDANCE WITH CHAPTER 177, FLORIDA STATUTES, THE POLK COUNTY SUBDIVISION REGULATIONS, AND IS IN CONFORMANCE WITH THE DENSITIES PERMITTED BY THE POLK COUNTY COMPREHENSIVE PLAN.

PREVUE HOMES, INC., A FLORIDA CORPORATION, OR ITS ASSIGNS, SHALL BE RESPONSIBLE FOR THE MAINTENANCE OF ALL PRIVATE COMMON AREAS INDICATED ON THE PLAT UNTIL SUCH TIMES AS A HOMEOWNERS ASSOCIATION IS CREATED AND MADE RESPONSIBLE FOR SUCH MAINTENANCE.

## Interpretation of Real Property Descriptions

---

After the plat is approved and recorded in the county records Lot 32 shown on the plat can therefore be described as follows:

**Lot 32**  
**Hillside Heights Subdivision**  
**Plat Book 115 Pages 43 & 44**  
**Polk County, Florida**

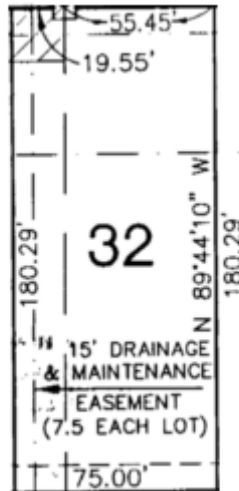

## **STRIP DESCRIPTIONS**

### **What is a Strip Description?**

A strip description is particularly suited for rights of way and easements since the parcel of land described runs in a “strip” and is quite often controlled by the centerline data.

Strip descriptions are nothing more than a metes and bounds description without a return to the Point of Beginning. The only thing to interpret differently than standard metes and bounds are:

- A. Are side widths mentioned?
- B. Is the side width on one side or both sides of the centerline?
- C. Are the methods of beginning and terminating the strip given?

If the side widths aren't given, there is not much one can do except call that failure to the attention of the preparer of the document. The document should state the widths such as “10 feet on each side of the following described centerline” or “10 ft on the east side of the following described centerline”. Without the reference to the width and whether it is on one side or both sides the only thing described is a “line”. If the beginning and terminating lines are not called out, then one has no choice but to assume that they are at ninety (90) degrees to the beginning and terminating points.

If the description states “a 10 foot strip along the front and rear lot lines” you should use the lot line that is along the street as the “front” and the back of the lot as the “rear”.

*The examples on the following pages give examples of different strip descriptions, giving descriptions with different methods of beginning and termination.*



## Strip Description Examples

### Strip Description Example: Point of Terminus Parallel & Perpendicular

#### EXAMPLE OF STRIP DESCRIPTION WITH POINT OF BEGINNING EXTENDED TO ROADWAY AND POINT OF TERMINUS PARALLEL AND PERPENDICULAR

A strip of land ten feet in width lying with Tract C, PUNTA GORDA ISLES, SECTION 27, a subdivision as recorded in Plat Book 15 on Pages 12A and 12B of the Public Records of Charlotte County, Florida; said strip of land lying five feet each side (as measured at right angles) of the following specifically described centerline:

From the centerline intersection of Shreve Street and West End Drive as shown on the plat of said Punta Gorda Isles, Section 27, N 40°45'18"W along the centerline of Shreve Street a distance of 60.00 feet to the Point of Curvature of a curve to the right having a central angle of 01°26'54" and a radius of 5518.00 feet; thence Northwesterly, along the arc of said curve a distance of 139.45 feet; thence S50°41'35"W on a radial bearing, a distance of 40.00 feet to the Southwesterly Right of Way Line of said Shreve Street and the POINT OF BEGINNING:

thence S 07°07'04"W a distance of 6.35 feet;  
thence S 07°48'37"E a distance of 23.74 feet;  
thence S 03°39'22"E a distance of 26.31 feet;  
thence S 20°13'45"E a distance of 37.14 feet;  
thence S 06°52'38"E a distance of 40.55 feet;  
thence S 21°49'04"W a distance of 51.37 feet;  
thence S 23°18'19"W a distance of 31.23 feet;  
thence S 37°59'00"W a distance of 30.05 feet;  
thence S 56°12'22"W a distance of 17.71 feet;  
thence S 88°05'38"W a distance of 17.77 feet;  
thence N 82°25'05"W a distance of 22.74 feet;  
thence N04°14'42"E a distance of 7.16 feet  
to the POINT OF TERMINATION.

Containing 3121 square feet or 0.072 acres, more or less.

The outside perimeters of the easement are to be extended or shortened as necessary to terminate the outside perimeter at the right of way line of said Shreve Street and at right angles to the last call (which is five feet, more or less, from a perimeter wall of the Punta Gorda Elderly Care Center).

**SEE DRAWING ON NEXT PAGE**



## Interpretation of Real Property Descriptions

---

### Strip Description Example: Perpendicular Ends

#### **EXAMPLE OF STRIP DESCRIPTION WITH TERMINATING CALL CLOSING BEING PERPENDICULAR TO ENDS**

A strip of land ten feet in width within a portion of the Southwest quarter of fractional Section 3, Township 41 South, Range 21 East in Charlotte County, Florida; said strip of land lying five feet each side (as measured a right angles) of the following specifically described centerline:

From the West quarter corner of said Section 3, bear S 00°34'35" W along the West line of the Southwest corner of said Section 3, a distance of 1047.04 feet; thence S89°25'25"E a distance of 879.60 feet to the POINT OF BEGINNING:

Thence continuing S89°25'25"E a distance of 5 feet to the end of three 2 inch diameter plastic conduits and continuing an additional 39.72 feet for a total distance of 44.72 feet to a point of deflection; thence N47°13'31"E a distance of 133.61 feet to the end of three 2 inch diameter plastic conduits and continuing 4 feet to a utility pole and continuing 5 feet for a total distance of 142.61 feet to the POINT OF TERMINATION.

Containing 1833 square feet, more or less (or 0.042 acres, more or less)

The perimeter lines of the above proposed easement are intended to be parallel, or perpendicular, as appropriate for the ends, and distant 5 feet from the center of the existing facilities.

**SEE NEXT PAGE FOR DRAWING**

# Interpretation of Real Property Descriptions

## DRAWING OF STRIP DESCRIPTION WITH POINT OF BEGINNING AND POINT OF TERMINUS BEING PARALLEL AND/OR PERPENDICULAR

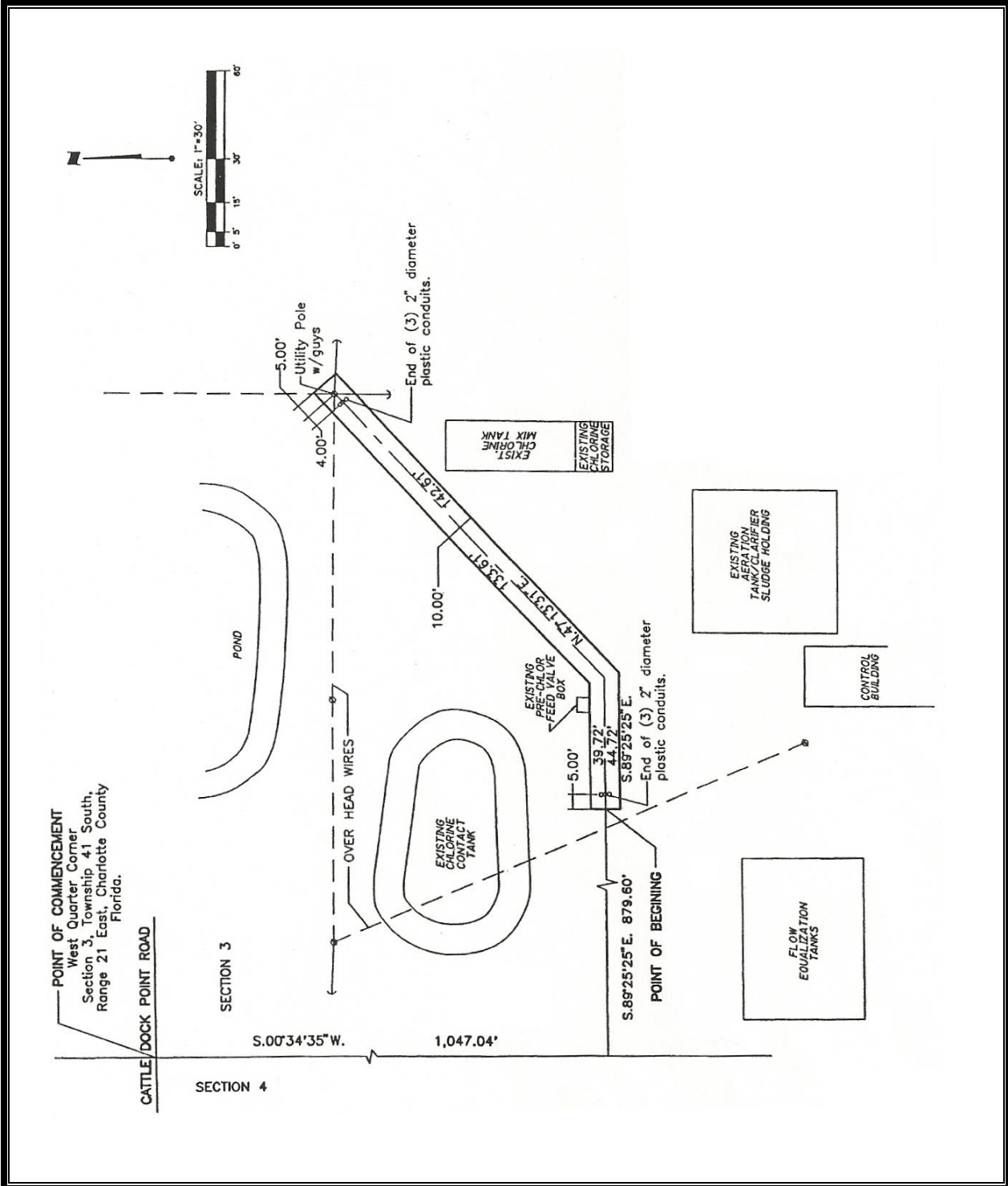



# Interpretation of Real Property Descriptions

---

## Subdivision & Strip Descriptions - Quiz

1. Which chapter of the Florida Statutes regulates the platting of land?  
\_\_\_\_\_
2. If the beginning and terminating lines are not called out in the description then what would you do?  
\_\_\_\_\_
3. The accuracy of the plat's perimeter is under the preview of the Minimum Technical Standards for Surveys in Florida.  
TRUE        FALSE
4. Governments use the \_\_\_\_\_ as a means to control what is happening in their jurisdiction.
5. What part of the plat will tell you whether the streets depicted in the plat are public streets or private streets?  
\_\_\_\_\_
6. A metes and bounds description that does not return to the point of beginning and states a side with on both sides of a centerline would be what type of description?  
\_\_\_\_\_
7. If you have a description for a centerline that does not state any side widths what would you do?  
\_\_\_\_\_
8. You should always verify that the \_\_\_\_\_ of the subdivision is exactly what is described in the plat legal description.
9. What is the bearing of a line called that is between two monuments or corners and which serves as the reference bearing for all other lines on the survey?  
\_\_\_\_\_
10. If a strip description starts with "A 20 foot strip lying along the front lot line of Lot 20 ...." how would you determine where the "front lot line" was?  
\_\_\_\_\_

## STATIONING

### **What is a Stationing?**

Highway stationing is a way of labeling measured increments along the centerline of a roadway to simplify locating a point on the centerline. It is a surveying or engineering form of measurement used in field books to be transferred to plans. It is only a tool to reduce the amount of graphic data that appears on plans. It would be difficult to describe a certain point on the centerline of a new (or old) roadway by specifying an amount of feet, or thousands of feet, from some known “base point”.

In many surveys, such as route surveys, the line is measured continuously from the starting point to the end point of the traverse. The starting point of the traverse is called “Station 0”; the next station 100 feet ahead is “Station 1”; the next is “Station 2”; the next is “Station 3”; etc. Every 100 foot length is a full station and any fractional distance is called the “plus”. A station 740.1 feet from Station 0 will be called “Station 7 + 40.1”.

The simplest method of stationing assumes that the station of the base point can be identified as zero, written 0 + 00. By using stationing, a point located 100 feet along the centerline from the 0 + 00 base point would be called station 1 + 00, pronounced one plus zero zero. A point 200 feet from the base point is station 2 + 00, pronounced two plus zero zero, and so on. Stations at very large distances from the base point do not use commas, so a station located 100,000 feet from the base point is called station 1000 + 00.

Points identified with more precision use a normal decimal point (for the decimal parts of a foot), as in station 149 + 23.79. To calculate the distance you would take  $149 * 100$ , since every station is 100 feet in length, to get a distance of 14,900 feet; then you would add 23.79 feet, for a total distance of 14,923.79 feet.

Base-point stations do not always commence with 0 + 00. Some roadways are extensions of other numbering systems. Normally, stations will increase from west to east and from south to north, but this is not always the case. There are also stations that end at county lines and begin anew with either + 00 or other designations mandated by the county in which the roadway exists. Divisions between states almost universally commence stationing that applies only to that particular state. In any event, typical sections are limited by virtue of beginning and ending stations.

In describing a road easement or right of way by a strip deed, the form “a right-of-way for road purposes over and across a strip of land lying 30 feet on each side of the following described centerline” is sometimes used. Generally, the stationing system starting from an arbitrary point called 0 + 00 and assigning each point on the line a station that is dependent on its distance from the starting point is used. If a point is 1237.62 feet from the arbitrary

## Interpretation of Real Property Descriptions

---

starting point, said distance being measured along the centerline of the strip, the station is 12 37.62. Every 100 feet along the centerline, be it on a curve or angle, is an “even” station. The **plus** number is added distance beyond the station; being a portion of a 100 foot “even” station.

The stationing system was devised for the convenience of the surveyor in note keeping and map notations. Any object along a right of way, such as a power pole, may be located by a simple note, “Sta. 15 + 12.70, 30’ rt.” When looking toward increasing station numbers, right is to your right. The “30’ rt.” means that the pole is located 30 feet to the right and is 90°, or radial, from the station indicated. Although this stationing system is legal, it deviated from the norm and is not seen in most modern descriptions, nor is it a recommended form of description.

All important points temporarily marked by stakes or nails should be “tied in” so that they may be readily found. At least three horizontal ties (measurements) to the nearest 0.01 foot should be noted by the surveyor from three readily identifiable and permanent points to the station in question. These points may be corners of buildings, nails in trees, drill holes in ledges, stone bounds, etc.

The basic highway reference line should be the center line of a normal two-way roadway. The basic reference line of divided highways may not be in the actual “center” of the highway and may be located either along the center line of the median or along the median edge of the traveled lane of the right-hand roadway in the direction of stationing. An auxiliary reference line along the median edge of the traveled lane of the left-hand roadway may be desirable when roadways are not parallel or concentric, or are widely separated.



# Interpretation of Real Property Descriptions

## Stationing Along Curves

When stationing along curves the surveyor will either show the stations along the arc of the curve or use several short tangents, as shown in Figure 1 below.

Stakes are driven on the line every 100 feet, thus determining the “stations”.

The changes in direction along the baseline will be noted by deflection angles as shown in the figure below.

In this figure the change in direction starts at station 4 + 40 (Point B), which would be 440 feet from the initial station point 0. At station 4 + 40 there is a deflection angle of  $29^{\circ}32'$  to the right. Then the stationing continues until reaching station 10 + 30 (Point C), which is 1030 feet from station 0 and 590 feet from Point B station 4 + 40. At station 10 + 30 you would deflect  $15^{\circ}35'$  to the left. The two stations where you find the deflection angle, Points B and C, are normally where you would find the PI's of the curves.

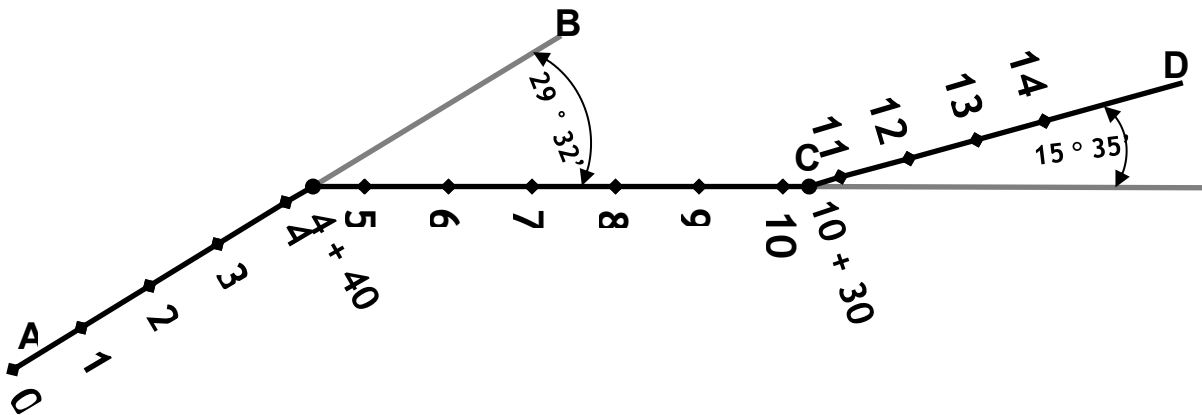
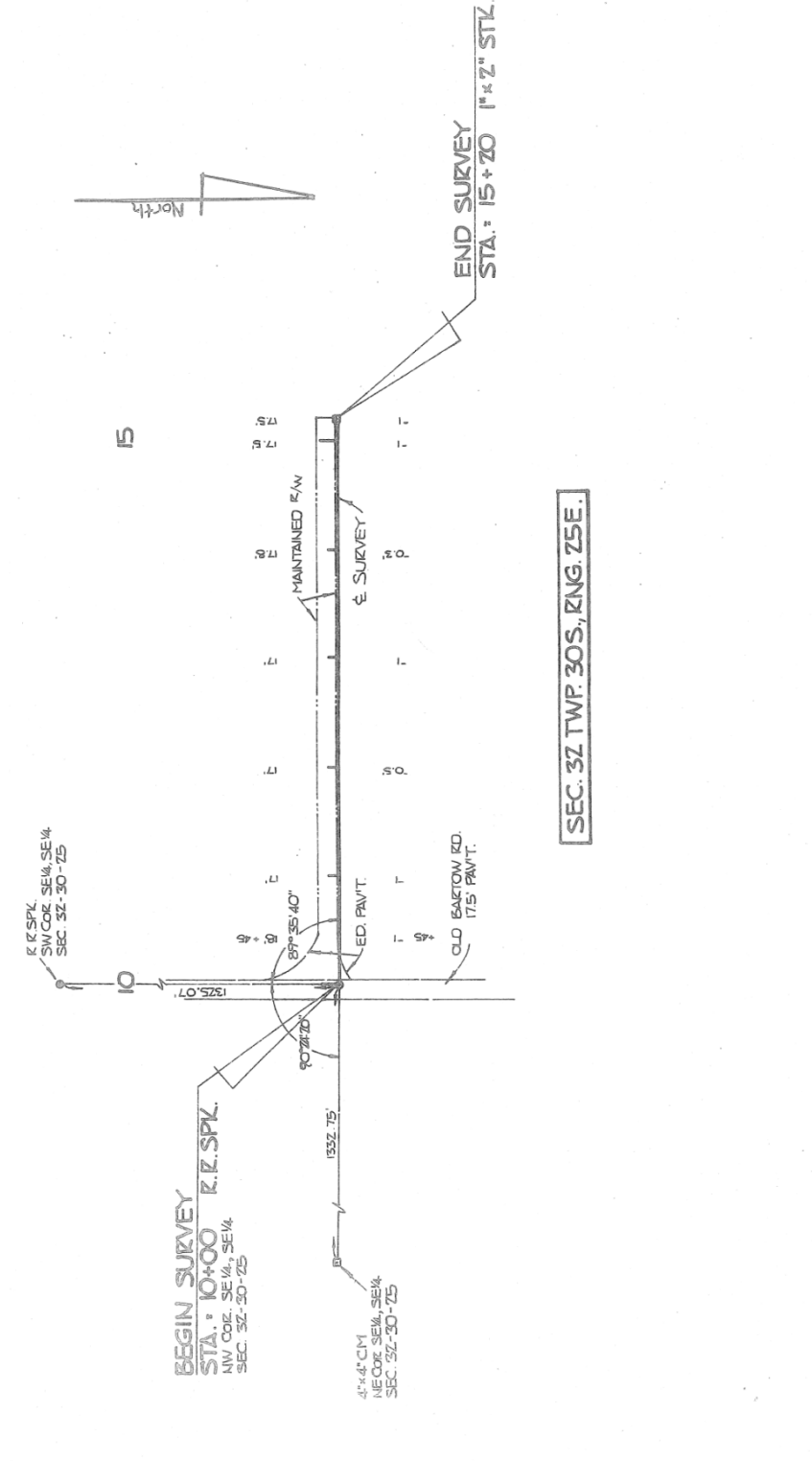

Figure 1

# Interpretation of Real Property Descriptions

## Exhibits: Legal Descriptions with stationing within description



# Interpretation of Real Property Descriptions

SEC. 28 TWP 30S., RNG 28E.

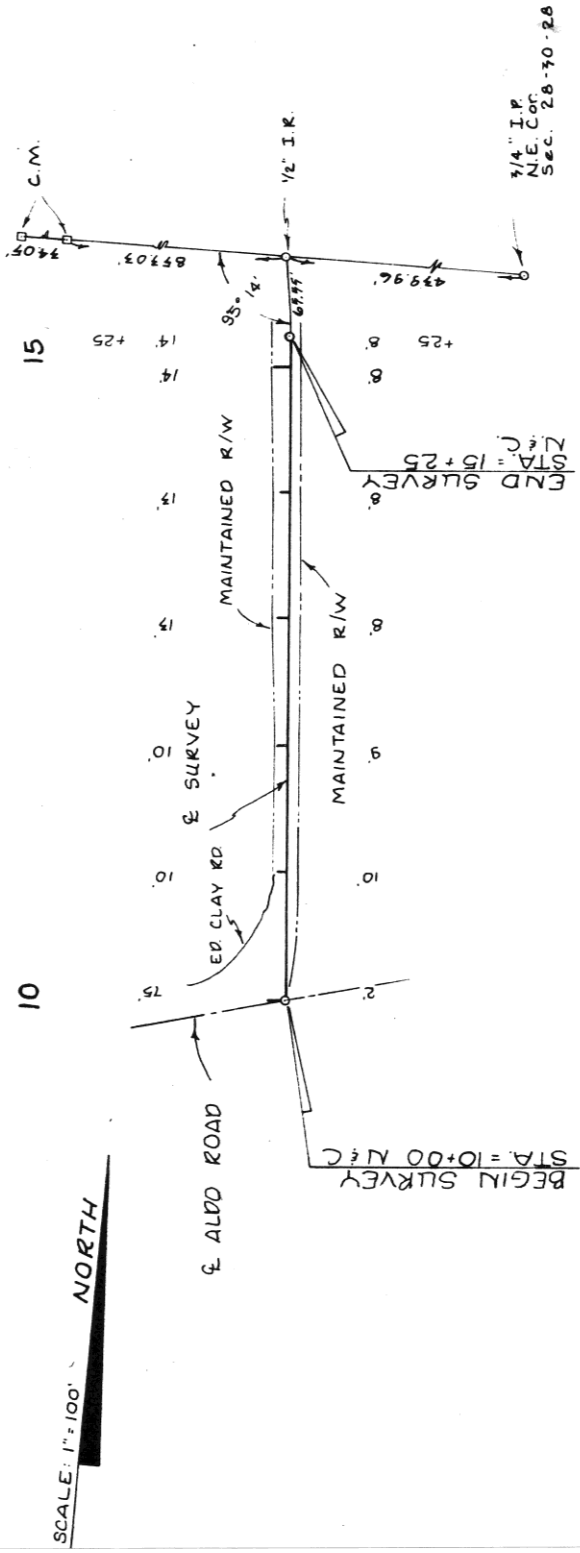

# Interpretation of Real Property Descriptions

LOCATED IN THE SOUTHWEST 1/4 OF SECTION 15,  
AND THE SOUTHEAST 1/4 OF SECTION 16  
TOWNSHIP 1 NORTH, RANGE 3 WEST OF THE WILLAMETTE MERIDIAN

**MOMUMENTS FOUND ON NW ROY ROAD RIGHT-OF-WAY**

POINT	STATION	OFFSET	NORTHING	EASTING	DESCRIPTION	REFERENCE
1109	0+00.00	0.00	702960.174	754951.301	FD 1.0' X 0.5' FLAT STONE, DOWN 1.8"	CS 1843
1015	7+69.40	-19.17	703604.755	7549092.292	FD 5/8" IR IN UP 0.2'	CS 9513
1031	12+92.79	20.24	704070.813	7548850.507	FD 5/8" IR IN 6" STEEL PIPE, UP 0.2'	CS 1275
1027	23+81.64	0.00	704886.033	7548260.553	FD 1/2" IP IN MON BOX	CS 1505
1025	30+42.89	0.00	705548.400	7547912.130	FD 1/2" IP IN MON BOX	CS 1503

NOTE: THE INFORMATION FOR THE MONUMENTS NOT IN RECOVERY TABLE IS SHOWN ON THE SHEETS WITH THE MONUMENTS THEMSELVES.



**NARRATIVE FOR NW ROY ROAD (CR A-25)**  
TO RETRACE THE CENTERLINE OF NW ROY ROAD (CR A-25) WE HELD A LINE BETWEEN MONUMENTS 1025 AND 1027 PER SURVEY 1889. SET IN SURVEY 1903 AND 1005 (A 1.00 FT X 0.50 FT STONE SET IN SURVEY 1903) WAS FOUND TO BE ON THIS LINE.  
MONUMENT 1027 (A 1/2" IRON PIPE SET IN SURVEY 1903)

**RIGHT-OF-WAY WIDTH AND STATIONING:**  
A STATUTORY WIDTH OF 60 FEET WAS HELD FOR NW ROY ROAD, OREGON STATUTE 1889. THIS WIDTH WAS ASSUMED PRIOR TO MAY 24, 1889. ALL COUNTY ROADS ESTABLISHED PRIOR TO MAY 24, 1889 ARE SUBJECT TO THIS STATUTE. THIS WIDTH WAS ASSUMED UNTIL A SURVEY WAS RECORDED IN 1884 THAT A WIDTH WAS ASSIGNED AND SPECIFIED TO BE 40 FEET. OTHER SURVEYS THEN USED THIS INFORMATION.  
STATIONING ON NW ROY ROAD IS ASSUMED.

**FD 3-1/4" ALUMINUM DISK**

SECTION CORNER	NO.	N	E
1005	1005	707,224.0663	707,224.0663
1006	1006	707,224.0663	707,224.0663
1007	1007	707,224.0663	707,224.0663
1008	1008	707,224.0663	707,224.0663
1009	1009	707,224.0663	707,224.0663
1010	1010	707,224.0663	707,224.0663

**MOMUMENTS FOUND ON NW CORNELIUS-SCHEFFLIN ROAD RIGHT-OF-WAY**

POINT	STATION	OFFSET	NORTHING	EASTING	DESCRIPTION	REFERENCE
1018	2+62.16	0.00	704035.44	755044.13	FD 5/8" IR W/IPC "RE MEYER CONSULTANTS INC., IN MON BOX (CS 25624)	CS 25624
1019	2+62.16	0.00	704035.44	755044.13	FD 5/8" IR W/IPC "RE MEYER CONSULTANTS INC., IN MON BOX (CS 25624)	CS 25624
1020	2+62.16	0.00	704035.44	755044.13	FD 5/8" IR W/IPC "RE MEYER CONSULTANTS INC., IN MON BOX (CS 25624)	CS 25624
1021	2+62.16	0.00	704035.44	755044.13	FD 5/8" IR W/IPC "RE MEYER CONSULTANTS INC., IN MON BOX (CS 25624)	CS 25624
1022	2+62.16	0.00	704035.44	755044.13	FD 5/8" IR W/IPC "RE MEYER CONSULTANTS INC., IN MON BOX (CS 25624)	CS 25624
1023	2+62.16	0.00	704035.44	755044.13	FD 5/8" IR W/IPC "RE MEYER CONSULTANTS INC., IN MON BOX (CS 25624)	CS 25624
1024	2+62.16	0.00	704035.44	755044.13	FD 5/8" IR W/IPC "RE MEYER CONSULTANTS INC., IN MON BOX (CS 25624)	CS 25624
1025	2+62.16	0.00	704035.44	755044.13	FD 5/8" IR W/IPC "RE MEYER CONSULTANTS INC., IN MON BOX (CS 25624)	CS 25624
1026	2+62.16	0.00	704035.44	755044.13	FD 5/8" IR W/IPC "RE MEYER CONSULTANTS INC., IN MON BOX (CS 25624)	CS 25624
1027	2+62.16	0.00	704035.44	755044.13	FD 5/8" IR W/IPC "RE MEYER CONSULTANTS INC., IN MON BOX (CS 25624)	CS 25624
1028	2+62.16	0.00	704035.44	755044.13	FD 5/8" IR W/IPC "RE MEYER CONSULTANTS INC., IN MON BOX (CS 25624)	CS 25624
1029	2+62.16	0.00	704035.44	755044.13	FD 5/8" IR W/IPC "RE MEYER CONSULTANTS INC., IN MON BOX (CS 25624)	CS 25624
1030	2+62.16	0.00	704035.44	755044.13	FD 5/8" IR W/IPC "RE MEYER CONSULTANTS INC., IN MON BOX (CS 25624)	CS 25624
1031	2+62.16	0.00	704035.44	755044.13	FD 5/8" IR W/IPC "RE MEYER CONSULTANTS INC., IN MON BOX (CS 25624)	CS 25624
1032	2+62.16	0.00	704035.44	755044.13	FD 5/8" IR W/IPC "RE MEYER CONSULTANTS INC., IN MON BOX (CS 25624)	CS 25624
1033	2+62.16	0.00	704035.44	755044.13	FD 5/8" IR W/IPC "RE MEYER CONSULTANTS INC., IN MON BOX (CS 25624)	CS 25624
1034	2+62.16	0.00	704035.44	755044.13	FD 5/8" IR W/IPC "RE MEYER CONSULTANTS INC., IN MON BOX (CS 25624)	CS 25624
1035	2+62.16	0.00	704035.44	755044.13	FD 5/8" IR W/IPC "RE MEYER CONSULTANTS INC., IN MON BOX (CS 25624)	CS 25624
1036	2+62.16	0.00	704035.44	755044.13	FD 5/8" IR W/IPC "RE MEYER CONSULTANTS INC., IN MON BOX (CS 25624)	CS 25624
1037	2+62.16	0.00	704035.44	755044.13	FD 5/8" IR W/IPC "RE MEYER CONSULTANTS INC., IN MON BOX (CS 25624)	CS 25624
1038	2+62.16	0.00	704035.44	755044.13	FD 5/8" IR W/IPC "RE MEYER CONSULTANTS INC., IN MON BOX (CS 25624)	CS 25624
1039	2+62.16	0.00	704035.44	755044.13	FD 5/8" IR W/IPC "RE MEYER CONSULTANTS INC., IN MON BOX (CS 25624)	CS 25624
1040	2+62.16	0.00	704035.44	755044.13	FD 5/8" IR W/IPC "RE MEYER CONSULTANTS INC., IN MON BOX (CS 25624)	CS 25624
1041	2+62.16	0.00	704035.44	755044.13	FD 5/8" IR W/IPC "RE MEYER CONSULTANTS INC., IN MON BOX (CS 25624)	CS 25624
1042	2+62.16	0.00	704035.44	755044.13	FD 5/8" IR W/IPC "RE MEYER CONSULTANTS INC., IN MON BOX (CS 25624)	CS 25624
1043	2+62.16	0.00	704035.44	755044.13	FD 5/8" IR W/IPC "RE MEYER CONSULTANTS INC., IN MON BOX (CS 25624)	CS 25624
1044	2+62.16	0.00	704035.44	755044.13	FD 5/8" IR W/IPC "RE MEYER CONSULTANTS INC., IN MON BOX (CS 25624)	CS 25624
1045	2+62.16	0.00	704035.44	755044.13	FD 5/8" IR W/IPC "RE MEYER CONSULTANTS INC., IN MON BOX (CS 25624)	CS 25624
1046	2+62.16	0.00	704035.44	755044.13	FD 5/8" IR W/IPC "RE MEYER CONSULTANTS INC., IN MON BOX (CS 25624)	CS 25624
1047	2+62.16	0.00	704035.44	755044.13	FD 5/8" IR W/IPC "RE MEYER CONSULTANTS INC., IN MON BOX (CS 25624)	CS 25624
1048	2+62.16	0.00	704035.44	755044.13	FD 5/8" IR W/IPC "RE MEYER CONSULTANTS INC., IN MON BOX (CS 25624)	CS 25624
1049	2+62.16	0.00	704035.44	755044.13	FD 5/8" IR W/IPC "RE MEYER CONSULTANTS INC., IN MON BOX (CS 25624)	CS 25624
1050	2+62.16	0.00	704035.44	755044.13	FD 5/8" IR W/IPC "RE MEYER CONSULTANTS INC., IN MON BOX (CS 25624)	CS 25624
1051	2+62.16	0.00	704035.44	755044.13	FD 5/8" IR W/IPC "RE MEYER CONSULTANTS INC., IN MON BOX (CS 25624)	CS 25624
1052	2+62.16	0.00	704035.44	755044.13	FD 5/8" IR W/IPC "RE MEYER CONSULTANTS INC., IN MON BOX (CS 25624)	CS 25624
1053	2+62.16	0.00	704035.44	755044.13	FD 5/8" IR W/IPC "RE MEYER CONSULTANTS INC., IN MON BOX (CS 25624)	CS 25624
1054	2+62.16	0.00	704035.44	755044.13	FD 5/8" IR W/IPC "RE MEYER CONSULTANTS INC., IN MON BOX (CS 25624)	CS 25624
1055	2+62.16	0.00	704035.44	755044.13	FD 5/8" IR W/IPC "RE MEYER CONSULTANTS INC., IN MON BOX (CS 25624)	CS 25624
1056	2+62.16	0.00	704035.44	755044.13	FD 5/8" IR W/IPC "RE MEYER CONSULTANTS INC., IN MON BOX (CS 25624)	CS 25624
1057	2+62.16	0.00	704035.44	755044.13	FD 5/8" IR W/IPC "RE MEYER CONSULTANTS INC., IN MON BOX (CS 25624)	CS 25624
1058	2+62.16	0.00	704035.44	755044.13	FD 5/8" IR W/IPC "RE MEYER CONSULTANTS INC., IN MON BOX (CS 25624)	CS 25624
1059	2+62.16	0.00	704035.44	755044.13	FD 5/8" IR W/IPC "RE MEYER CONSULTANTS INC., IN MON BOX (CS 25624)	CS 25624
1060	2+62.16	0.00	704035.44	755044.13	FD 5/8" IR W/IPC "RE MEYER CONSULTANTS INC., IN MON BOX (CS 25624)	CS 25624
1061	2+62.16	0.00	704035.44	755044.13	FD 5/8" IR W/IPC "RE MEYER CONSULTANTS INC., IN MON BOX (CS 25624)	CS 25624
1062	2+62.16	0.00	704035.44	755044.13	FD 5/8" IR W/IPC "RE MEYER CONSULTANTS INC., IN MON BOX (CS 25624)	CS 25624
1063	2+62.16	0.00	704035.44	755044.13	FD 5/8" IR W/IPC "RE MEYER CONSULTANTS INC., IN MON BOX (CS 25624)	CS 25624
1064	2+62.16	0.00	704035.44	755044.13	FD 5/8" IR W/IPC "RE MEYER CONSULTANTS INC., IN MON BOX (CS 25624)	CS 25624
1065	2+62.16	0.00	704035.44	755044.13	FD 5/8" IR W/IPC "RE MEYER CONSULTANTS INC., IN MON BOX (CS 25624)	CS 25624
1066	2+62.16	0.00	704035.44	755044.13	FD 5/8" IR W/IPC "RE MEYER CONSULTANTS INC., IN MON BOX (CS 25624)	CS 25624
1067	2+62.16	0.00	704035.44	755044.13	FD 5/8" IR W/IPC "RE MEYER CONSULTANTS INC., IN MON BOX (CS 25624)	CS 25624
1068	2+62.16	0.00	704035.44	755044.13	FD 5/8" IR W/IPC "RE MEYER CONSULTANTS INC., IN MON BOX (CS 25624)	CS 25624
1069	2+62.16	0.00	704035.44	755044.13	FD 5/8" IR W/IPC "RE MEYER CONSULTANTS INC., IN MON BOX (CS 25624)	CS 25624
1070	2+62.16	0.00	704035.44	755044.13	FD 5/8" IR W/IPC "RE MEYER CONSULTANTS INC., IN MON BOX (CS 25624)	CS 25624
1071	2+62.16	0.00	704035.44	755044.13	FD 5/8" IR W/IPC "RE MEYER CONSULTANTS INC., IN MON BOX (CS 25624)	CS 25624
1072	2+62.16	0.00	704035.44	755044.13	FD 5/8" IR W/IPC "RE MEYER CONSULTANTS INC., IN MON BOX (CS 25624)	CS 25624
1073	2+62.16	0.00	704035.44	755044.13	FD 5/8" IR W/IPC "RE MEYER CONSULTANTS INC., IN MON BOX (CS 25624)	CS 25624
1074	2+62.16	0.00	704035.44	755044.13	FD 5/8" IR W/IPC "RE MEYER CONSULTANTS INC., IN MON BOX (CS 25624)	CS 25624
1075	2+62.16	0.00	704035.44	755044.13	FD 5/8" IR W/IPC "RE MEYER CONSULTANTS INC., IN MON BOX (CS 25624)	CS 25624
1076	2+62.16	0.00	704035.44	755044.13	FD 5/8" IR W/IPC "RE MEYER CONSULTANTS INC., IN MON BOX (CS 25624)	CS 25624
1077	2+62.16	0.00	704035.44	755044.13	FD 5/8" IR W/IPC "RE MEYER CONSULTANTS INC., IN MON BOX (CS 25624)	CS 25624
1078	2+62.16	0.00	704035.44	755044.13	FD 5/8" IR W/IPC "RE MEYER CONSULTANTS INC., IN MON BOX (CS 25624)	CS 25624
1079	2+62.16	0.00	704035.44	755044.13	FD 5/8" IR W/IPC "RE MEYER CONSULTANTS INC., IN MON BOX (CS 25624)	CS 25624
1080	2+62.16	0.00	704035.44	755044.13	FD 5/8" IR W/IPC "RE MEYER CONSULTANTS INC., IN MON BOX (CS 25624)	CS 25624
1081	2+62.16	0.00	704035.44	755044.13	FD 5/8" IR W/IPC "RE MEYER CONSULTANTS INC., IN MON BOX (CS 25624)	CS 25624
1082	2+62.16	0.00	704035.44	755044.13	FD 5/8" IR W/IPC "RE MEYER CONSULTANTS INC., IN MON BOX (CS 25624)	CS 25624
1083	2+62.16	0.00	704035.44	755044.13	FD 5/8" IR W/IPC "RE MEYER CONSULTANTS INC., IN MON BOX (CS 25624)	CS 25624
1084	2+62.16	0.00	704035.44	755044.13	FD 5/8" IR W/IPC "RE MEYER CONSULTANTS INC., IN MON BOX (CS 25624)	CS 25624
1085	2+62.16	0.00	704035.44	755044.13	FD 5/8" IR W/IPC "RE MEYER CONSULTANTS INC., IN MON BOX (CS 25624)	CS 25624
1086	2+62.16	0.00	704035.44	755044.13	FD 5/8" IR W/IPC "RE MEYER CONSULTANTS INC., IN MON BOX (CS 25624)	CS 25624
1087	2+62.16	0.00	704035.44	755044.13	FD 5/8" IR W/IPC "RE MEYER CONSULTANTS INC., IN MON BOX (CS 25624)	CS 25624
1088	2+62.16	0.00	704035.44	755044.13	FD 5/8" IR W/IPC "RE MEYER CONSULTANTS INC., IN MON BOX (CS 25624)	CS 25624
1089	2+62.16	0.00	704035.44	755044.13	FD 5/8" IR W/IPC "RE MEYER CONSULTANTS INC., IN MON BOX (CS 25624)	CS 25624
1090	2+62.16	0.00	704035.44	755044.13	FD 5/8" IR W/IPC "RE MEYER CONSULTANTS INC., IN MON BOX (CS 25624)	CS 25624
1091	2+62.16	0.00	704035.44	755044.13	FD 5/8" IR W/IPC "RE MEYER CONSULTANTS INC., IN MON BOX (CS 25624)	CS 25624
1092	2+62.16	0.00	704035.44	755044.13	FD 5/8" IR W/IPC "RE MEYER CONSULTANTS INC., IN MON BOX (CS 25624)	CS 25624
1093	2+62.16	0.00	704035.44	755044.13	FD 5/8" IR W/IPC "RE MEYER CONSULTANTS INC., IN MON BOX (CS 25624)	CS 25624
1094	2+62.16	0.00	704035.44	755044.13	FD 5/8" IR W/IPC "RE MEYER CONSULTANTS INC., IN MON BOX (CS 25624)	CS 25624
1095	2+62.16	0.00	704035.44	755044.13	FD 5/8" IR W/IPC "RE MEYER CONSULTANTS INC., IN MON BOX (CS 25624)	CS 25624
1096	2+62.16	0.00	704035.44	755044.13	FD 5/8" IR W/IPC "RE MEYER CONSULTANTS INC., IN MON BOX (CS 25624)	CS 25624
1097	2+62.16	0.00	704035.44	755044.13	FD 5/8" IR W/IPC "RE MEYER CONSULTANTS INC., IN MON BOX (CS 25624)	CS 25624
1098	2+62.16	0.00	704035.44	755044.13	FD 5/8" IR W/IPC "RE MEYER CONSULTANTS INC., IN MON BOX (CS 25624)	CS 25624
1099	2+62.16	0.00	704035.44	755044.13	FD 5/8" IR W/IPC "RE MEYER CONSULTANTS INC., IN MON BOX (CS 25624)	CS 25624
1100	2+62.16	0.00	704035.44	755044.13	FD 5/8" IR W/IPC "RE MEYER CONSULTANTS INC., IN MON BOX (CS 25624)	CS 25624

NOTE: THE INFORMATION FOR THE MONUMENTS NOT IN RECOVERY TABLE IS SHOWN ON THE SHEETS WITH THE MONUMENTS THEMSELVES.

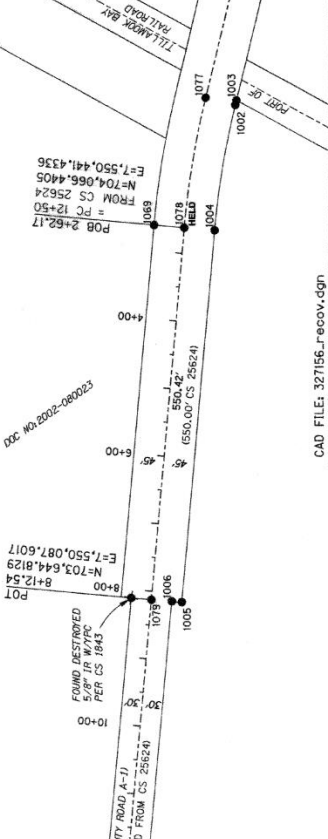

**MONUMENT RECOVERY, RETRACEMENT SURVEY -**  
NW CORNELIUS-SCHEFFLIN ROAD  
FOR WASHINGTON COUNTY PROJECT NO. 2537  
IN WASHINGTON COUNTY, OREGON

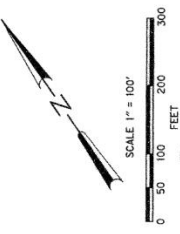

- ABBREVIATIONS**
- FD - FOUND
  - IR - IRON ROD
  - IP - IRON PIPE
  - W/IPC - WITH IRON PIPE CAP
  - W/ALUM - WITH ALUMINUM CAP
  - CS - COUNTY SURVEY NUMBER
  -

# Interpretation of Real Property Descriptions

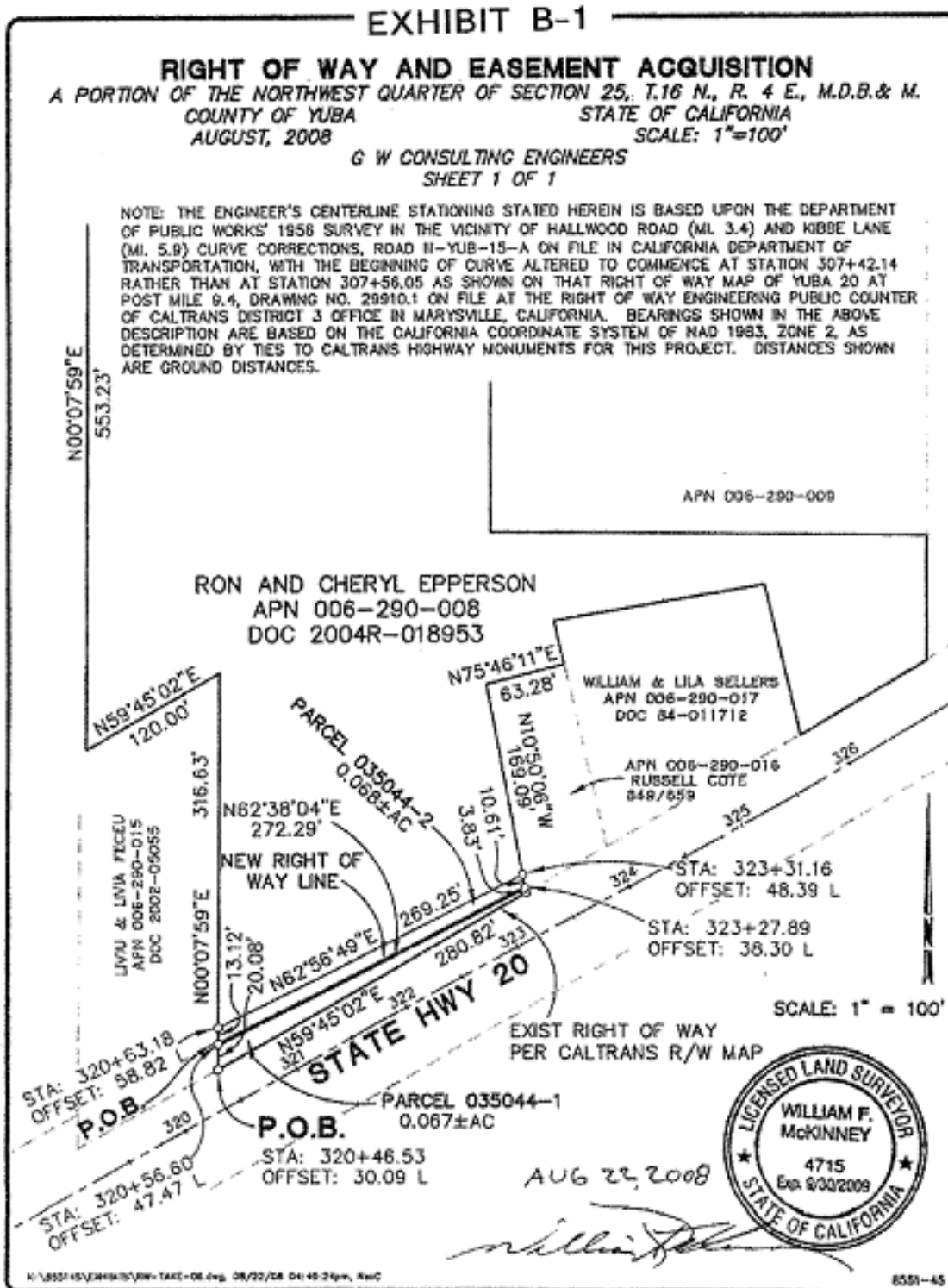

# Interpretation of Real Property Descriptions

---

## EXHIBIT B-1 Legal Description

Parcel 035.044-1

The land described herein is situated in the State of California, County of Yuba, unincorporated area, and is described as follows:

All that portion of the northwest quarter of Section 25, Township 16 North, Range 4 East, M.D.B. & M., described as follows:

BEGINNING at a point on the northwesterly line of existing State Highway No. 20, said point also being the most southwesterly corner of that certain parcel of land described in Grant Deed to Ron Epperson and Cheryl Epperson filed for record in the Office of the Recorder of Yuba County in Document No. 2004R-018953 of Official Records, said Epperson property is also shown on that certain Record of Survey file for record in said Recorder's office in Book 48 of Maps, page 45 of official records, said point also being located 30.09 feet left of State Highway No. 20 centerline station 320+46.53; thence from said POINT OF BEGINNING along the westerly line of said Epperson property North 00°07'59" East 20.08 feet to a point located 47.47 feet left of State Highway No. 20 centerline station 320+56.60; thence North 62°38'04" East 272.29 feet more or less to a point on the easterly line of said Epperson property located 38.30 feet left of State Highway No. 20 centerline station 323+27.89; thence along said easterly line South 10°50'06" East 3.83 feet to a point on the northwesterly line of said State Highway No. 20; thence along said northwesterly line South 59°45'02" West 280.82 feet more or less to the POINT OF BEGINNING, containing 0.067 acres more or less.

Note: The Engineer's centerline stationing stated herein is based upon "the Department of Public Works' 1956 survey in the vicinity of Hallwood Road (Mi. 3.4) and Kibbe Lane (Mi. 5.9) curve corrections, Road III• Yub-IS-A on file in California Department of Transportation, with the beginning of curve altered to commence at station 307+42.14 rather than at station 307+56.05 as shown on that Right of Way map of Yuba 20 at Post. Mile 9.4, Drawing No. 29910.1 on file at the Right of Way Engineering public counter of Caltrans District 3 office in Marysville, California. Bearings shown in the above description are based on the California Coordinate System of NAD 1983, Zone 2, as determined by ties to Caltrans highway monuments for this project, Distances shown are ground distances.

K:\8S5145\rw-take-08.doc

# Interpretation of Real Property Descriptions

---

## Stationing - Quiz

1. Your survey shows a fence line starting at station  $50 + 22.1$  and going to station  $80 + 38.5$ . What length of fence (in feet) is needed?  
\_\_\_\_\_
2. Stations usually will be \_\_\_\_\_ feet apart on a right-of-way map.
3. What angle is usually shown on a centerline right-of-way sketch that will mean that there is a curve in the right-of-way?  
\_\_\_\_\_
4. The starting point of the traverse is usually called \_\_\_\_\_.
5. Every fractional distance of a station is called \_\_\_\_\_.
6. A station 120,000 feet from the base point will be shown as station \_\_\_\_\_.
7. Stations will always start with  $0 + 00$ .  
TRUE            FALSE

=====

The maintained right-of way map you are reviewing starts at station  $10 + 00$  and ends at station  $91 + 23.44$ . There are stations noted that show the location of an intersection of Deerview Drive at  $38 + 23.44$ , the location of a change in width at  $48 + 62.66$ , the beginning of a curve (PC) at station  $54 + 75.23$ , the location of a power pole is noted at  $58 + 2.99$ , 40' rt., and the location in a change in direction of the right-of-way at station  $82 + 59.78$ . If necessary, sketch the map on a separate piece of paper and answer questions 8 thru 15 below:

8. What is the distance between the end of the centerline of right-of-way and the PC of curve?  
\_\_\_\_\_
9. What is the distance between the beginning station and the intersection with Deerview Drive? \_\_\_\_\_
10. What is the distance between the change in width of the road and the PC of curve?  
\_\_\_\_\_

## Interpretation of Real Property Descriptions

---

11. What is the distance between the intersection with Deerview Drive and the change in direction of the right-of-way?  
\_\_\_\_\_
12. What is the distance between the change in width of the road and the end of the right-of-way line?  
\_\_\_\_\_
13. What is the distance between the beginning of the right-of-way line and the end of the right-of way line?  
\_\_\_\_\_
14. What is the distance between the intersection with Deerview Drive and the PC of curve?  
\_\_\_\_\_
15. The power pole is located \_\_\_\_\_ feet to the \_\_\_\_\_ of station 58 + 2.99 and is \_\_\_\_\_ degrees from said station.



# Interpretation of Real Property Descriptions

## Day 3 Homework:

### Stationing on Curves

Identify parts of Curve 1 and Sketch and identify parts of Curve 2

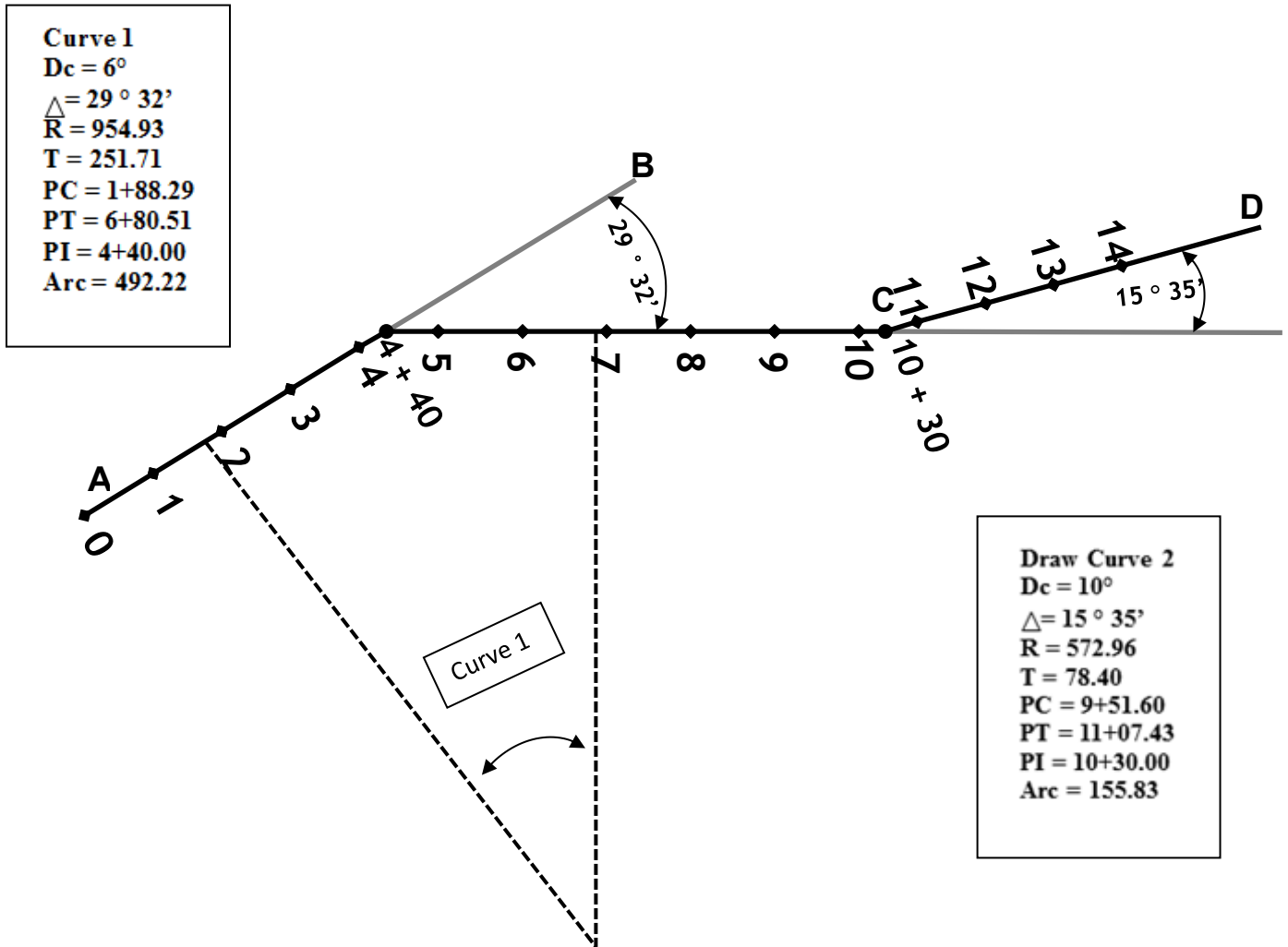

## Mapping in the Office of the Property Appraiser

### General Information

In general, any abbreviation or character which is in common use, and definitely identified with a particular word or phrase, is legally usable in a description. However, safety demands the use of full words in cases of uncertainty or infrequent use of the abbreviation, or if the abbreviation is common to more than one term (such as LC for long chord or length of curve).

Bearings may be written using the abbreviation of the direction using a letter (such as N, S, E, and W for North, South, East, and West) and the figures with the engineering symbols for the quantity of degrees, minutes, and seconds; N 80° 10' 17"E. You might also see this written as N 80-10-37 E in some descriptions.

All bearings except the cardinal ones (N, S, E, W) should show degrees, minutes, and seconds, substituting zeros if no finite quantity is given (N0° 00' 06" E); using one zero for degrees and two for minutes or seconds, with one preceding the minutes or seconds as the case may be if less than two significant figures. It is unnecessary, however, to carry zeros in the minutes, or seconds, if there is no subsequent quantity. Therefore, if there are no minutes or seconds and the direction is 10 degrees it would simply be shown as 10°; if there were no seconds in the direction of 8 degrees five minutes and zero seconds it would simply be shown as 8°05'. Be careful of writing something like 26" because it could be construed as 26 inches and it also would not be wise to enter N 26"E. It would be best to completely write this out as N 0°00'26" E to be more accurate and leave out any possibility of someone misinterpreting this as N26°E or N 26'E.

The foot (') mark and inch (") mark are usable but because of the similarity of minutes and seconds used within a description the preferred words or abbreviations for foot and inch would be the word "foot" or the abbreviation "ft." and the word "inches" or the abbreviation "in.".

Remember, for clarity sake, it is usually better to limit abbreviations in a description and certainly only use common abbreviations and figures. Chapter 12D-8.009 of the Florida Administrative Code provides additional guidance for the preparation of assessment descriptions and is included as follows:

### **12D-8.008 Additional Requirements for Preparation of the Real Property Roll**

(1) In addition to the requirements of Rule 12D-8.007, F.A.C., the Real Property Roll for each county shall include a description of the property assessed or a cross-reference to the description which shall be accurate and certain enough to give to the taxpayer the necessary notice of the tax assessed against the particular piece of property; the description so cross-

## Interpretation of Real Property Descriptions

---

referenced shall afford an adequate conveyance to the purchaser at a sale of the property for satisfaction of a lien originating in the non-payment of the tax. The Official Record Book and Page number of the conveyance upon which the owner of record's title is based shall also be shown, provided such information has been gathered pursuant to Rule 12D-8.011(1)(m), F.A.C.

(a) All descriptions of real property shall be based upon reference to the government grid system survey (Section, Township, Range) in general use in this state, provided:

1. Where real property has been subdivided into lots according to a map or plat duly

recorded in the office of the Clerk of Circuit Court of the county in which the lands are located, or is a condominium or co-operative apartment, the description of real property shall, in addition to Section, Township, Range, be based upon reference to such map or plat. (Crawford v. Rehwinkel, 163 So. 851. (Fla. 1935))

2. For Spanish Grants or donations which have not been surveyed and platted, or

where if platted, the plat is not recorded in the office of the Clerk of the Circuit Court, the description of real property may also include a reference to deed of record, giving the book and page as it appears in the office of the Clerk of the Circuit Court.

(b) Metes and bounds descriptions making reference to the government survey for determination of the point of beginning and closing of such description are considered for the purposes of this rule to be based upon the government survey.

(c) Abbreviations and figures may be used in descriptions if they are of general use and acceptance, not misleading, and indicate with certainty the thing intended.

(d) For the purposes of uniformity, if and when the following abbreviations and figures are used, they shall have the following meaning.

### **ABBREVIATION MEANING**

Ac	Acre
Add	Addition
Et Al	And Others
Et Ux	And Wife
Beg.	Beginning
Bdy., Bdys.	Boundary, Boundaries
Blk.	Block
Cen.	Center
C. L.	Center Line
Ch.	Chain
Com.	Commence, Commencing
Cont.	Continue

## Interpretation of Real Property Descriptions

---

Cor., Cors.	Corner, Corners
Desc.	Description
Deg.	Degree
E, E'ly	East, Easterly
Exc.	Except
Ft.	Foot or Feet
1/4 or Qtr.	Fourth or Quarter
Frac.	Fraction
Fracl.	Fractional
Govt. Lot	Government Lot
1/2	Half
Hwy.	Highway
In.	Inch, Inches
Int.	Intersection
Lk., Lks.	Link, Links
Mer.	Meridian
Mi.	Mile
' or M.	Minutes
M. or L.	M/L More or Less
N, N'ly	North, Northerly
NE	Northeast
NE'ly	Northeasterly
NW	Northwest
NW'ly	Northwesterly
No.	Number
P.	Page
//	Parallel
Pt.	Point
P.O.B.	Point of Beginning
Qtr. or 1/4	Quarter or Fourth
Rad.	Radius
R.R.	Railroad
Rwy.	Railway
R., Rs.	Range, Ranges
Rt.	Right
R/W or R.O.W.	Right-of-Way
Rds.	Rods
Rgn.	Running
" or S.	Seconds
Sec., Secs.	Section, Sections
Sq.	Square
S, S'ly	South, Southerly
SE	Southeast
SE'ly	Southeasterly
SW	Southwest
SW'ly	Southwesterly

## Interpretation of Real Property Descriptions

---

St., Sts.	Street, Streets
S/D	Subdivision
Th.	Thence
Twp., Twps.	Township, Townships
W	West
W'ly	Westerly

(e) A unique parcel number derived from a parcel numbering system applied uniformly throughout the county.

(f) When a code or reference number system is used for describing property, an explanation of how to read the code or reference number system (referred to as a "key") shall be made available.

(g) 1. For the purpose of accounting for all real property within the county, the property appraiser shall list all centrally assessed real property in its proper place on the Real Property Roll as required by this rule with the notation "See Centrally Assessed Property Roll", but no tax shall be extended against same, and the value of such property need not be shown. Provided, however, when the legal description for railroad right-of-way is not furnished by the Department or is not otherwise available, such property need not be listed on the real property roll. All tabulations of value, parcels, etc., for the Real Property Roll shall not include centrally assessed property. Taxes shall be extended against centrally assessed real property, centrally assessed tangible personal property, and centrally assessed inventory listed on the Centrally Assessed Tangible Personal Property Roll and inventory shall not be listed on the Tangible Personal Property Assessment Roll.

2. When property is classified (lands classified agricultural for ad valorem tax purposes; outdoor recreational and park land) so that its taxable value is determined on a basis other than under section 193.011, Florida Statutes, the value according to its classified use, less any exemptions allowed shall be its value for tax purposes. In addition to its value determined under section 193.011, Florida Statutes, the value of the property according to its classified use shall be entered on the assessment roll either under the appropriate column heading (e.g., Classified Use Value) or with proper identifying words, abbreviations, code symbols, or figures set opposite it. In either case a notation shall be made identifying the classified use value as agricultural (e.g., "A"), park or outdoor recreational land (e.g., "PR.").

(h) When more than one listing is required to be made on the same property (as in the case of a taxable possessory interest in property which is otherwise exempt or immune, and mineral, oil, gas and other subsurface rights in or to real property which have been separated from the fee) the appraiser shall, immediately following the entry listing the record title owner or the record title owner of the surface fee, as the case may be, make a separate entry or entries on the assessment roll indicating the assessment of the taxable possessory interest or the

## Interpretation of Real Property Descriptions

---

assessment of the mineral, oil, gas and other subsurface rights in or to real property which have been separated from the fee.

(2) Classification of Property.

(a) The appraiser shall classify each parcel of real property to indicate the use of the

land as arrived at by the appraiser for valuation purposes and indicate the same on the assessment roll according to the codes listed below. This use will not always be the use for which the property is zoned or the use for which the improvements were designed whenever there is, in the appraiser's judgment, a higher and better use for the land. When more than one land use code is applicable to a parcel, the appraiser may list either multiple land use codes with an indication of the portion of total property ascribed to each use, or a single code indicating the primary and predominant use. If multiple codes are listed, the code shown first shall represent the primary and predominant use. For land classified "agricultural", the primary and predominant use shall mean the use code representing the most acreage. For example, if the use of 100 acres contains 40 acres of cropland (code 52), 30 acres of timberland (code 54), 15 acres of grazing land (code 61), and 15 acres of citrus groves (code 66), the first two-digit code in the "land use" field in the Name-Address-Legal (NAL) file should be "52"; the next part of that field could be coded "54" or "61" or "66" based upon a method consistently used by the property appraiser. Taxable possessory interests shall be classified as code 90 or 93 as appropriate.

(b) Real property shall be classified based on ten major groups. The classification

"residential" shall be subclassified into two categories--homestead and non-homestead property. The major groups are:

1. Residential:
  - a. Homestead
  - b. Non-homestead
2. Commercial and Industrial
3. Agricultural
4. Exempt, wholly or partially
5. Leasehold Interest (Government owned)
6. Other
7. Centrally Assessed
8. Non-Agricultural Acreage
9. Time-share Property
10. High-water recharge.

(c) Following is a detailed list of the classifications and subclassifications which shall be used, and the numeric code designation for each. The description beside the code number defines the category of property and illustrates the uses of property to be included. Upon request, the

## Interpretation of Real Property Descriptions

---

Department of Revenue will advise the appraiser of the classification under which specific uses not listed below should be placed. The appraiser may divide any of the 100 listed categories (except for undefined code numbers which are reserved for future definition by the Department of Revenue) into finer categories as long as the definition of the herein listed categories is not expanded. The code numbers for finer categories shall consist of the four digits defined herein.

### USE

#### CODE

#### PROPERTY TYPE

#### Residential

0000	Vacant Residential
0100	Single Family
0200	Mobile Homes
0300	Multi-family - 10 units or more
0400	Condominia
0500	Cooperatives
0600	Retirement Homes (not eligible for exemption under section 196.192, Florida Statutes. Others shall be given an Institutional classification)
0700	Miscellaneous Residential (migrant camps, boarding homes, etc.)
0800	Multi-family - less than 10 units
0900	Undefined - Reserved for Use by Department of Revenue only

#### Commercial

1000	Vacant Commercial
1100	Stores, one story
1200	Mixed use - store and office or store and residential or residential combination
1300	Department Stores
1400	Supermarkets
1500	Regional Shopping Centers
1600	Community Shopping Centers
1700	Office buildings, non-professional service buildings, one story
1800	Office buildings, non-professional service buildings, multi-story
1900	Professional service buildings
2000	Airports (private or commercial), bus terminals, marine terminals, piers, marinas
2100	Restaurants, cafeterias
2200	Drive-in Restaurants
2300	Financial institutions (banks, savings and loan companies, mortgage companies, credit services)
2400	Insurance company offices
2500	Repair service shops (excluding automotive), radio and T.V. repair, refrigeration service, electric repair, laundries, laundromats
2600	Service stations

# Interpretation of Real Property Descriptions

---

2700	Auto sales, auto repair and storage, auto service shops, body and fender shops, commercial garages, farm and machinery sales and services, auto rental, marine equipment, trailers and related equipment, mobile home sales, motorcycles, construction vehicle sales
2800	Parking lots (commercial or patron), mobile home parks
2900	Wholesale outlets, produce houses, manufacturing outlets
3000	Florist, greenhouses
3100	Drive-in theaters, open stadiums
3200	Enclosed theaters, enclosed auditoriums
3300	Nightclubs, cocktail lounges, bars
3400	Bowling alleys, skating rinks, pool halls, enclosed arenas
3500	Tourist attractions, permanent exhibits, other entertainment facilities, fairgrounds (privately owned)
3600	Camps
3700	Race tracks; horse, auto or dog
3800	Golf courses, driving ranges
3900	Hotels, motels

## **Industrial**

4000	Vacant Industrial
4100	Light manufacturing, small equipment manufacturing plants, small Machine shops, instrument manufacturing printing plants
4200	Heavy industrial, heavy equipment manufacturing, large machine shops, foundries, steel fabricating plants, auto or aircraft plants
4300	Lumber yards, sawmills, planing mills
4400	Packing plants, fruit and vegetable packing plants, meat packing plants
4500	Canneries, fruit and vegetable, bottlers and brewers distilleries, wineries
4600	Other food processing, candy factories, bakeries, potato chip factories
4700	Mineral processing, phosphate processing, cement plants, refineries, clay plants, rock and gravel plants
4800	Warehousing, distribution terminals, trucking terminals, van and Storage warehousing
4900	Open storage, new and used building supplies, junk yards, auto wrecking, fuel storage, equipment and material storage

## **Agricultural**

5000	Improved agricultural
5100	Cropland soil capability Class I
5200	Cropland soil capability Class II
5300	Cropland soil capability Class III
5400	Timberland - site index 90 and above
5500	Timberland - site index 80 to 89
5600	Timberland - site index 70 to 79
5700	Timberland - site index 60 to 69
5800	Timberland - site index 50 to 59



# Interpretation of Real Property Descriptions

---

5900	Timberland not classified by site index to Pines
6000	Grazing land soil capability Class I
6100	Grazing land soil capability Class II
6200	Grazing land soil capability Class III
6300	Grazing land soil capability Class IV
6400	Grazing land soil capability Class V
6500	Grazing land soil capability Class VI
6600	Orchard Groves, Citrus, etc.
6700	Poultry, bees, tropical fish, rabbits, etc.
6800	Dairies, feed lots
6900	Ornamentals, miscellaneous agricultural

## **Institutional**

7000	Vacant
7100	Churches
7200	Private schools and colleges
7300	Privately owned hospitals
7400	Homes for the aged
7500	Orphanages, other non-profit or charitable services
7600	Mortuaries, cemeteries, crematoriums
7700	Clubs, lodges, union halls
7800	Sanitariums, convalescent and rest homes
7900	Cultural organizations, facilities

## **Government**

8000	Undefined - Reserved for future use
8100	Military
8200	Forest, parks, recreational areas
8300	Public county schools - include all property of Board of Public Instruction
8400	Colleges
8500	Hospitals
8600	Counties (other than public schools, colleges, hospitals) including non-municipal governments
8700	State, other than military, forests, parks, recreational areas, colleges, hospitals
8800	Federal, other than military, forests, parks, recreational areas, hospitals, colleges
8900	Municipal, other than parks, recreational areas, colleges, hospitals

## **Miscellaneous**

9000	Leasehold interests (government owned property leased by a non-Governmental lessee)
9100	Utility, gas and electricity, telephone and telegraph, locally assessed railroads, water and sewer service, pipelines, canals, radio/television communication

# Interpretation of Real Property Descriptions

---

9200	Mining lands, petroleum lands, or gas lands
9300	Subsurface rights
9400	Right-of-way, streets, roads, irrigation channel, ditch, etc.
9500	Rivers and lakes, submerged lands
9600	Sewage disposal, solid waste, borrow pits, drainage reservoirs, waste lands, marsh, sand dunes, swamps
9700	Outdoor recreational or parkland, or high-water recharge subject to classified use assessment.

## Centrally Assessed

9800	Centrally assessed Non-Agricultural Acreage
9900	Acreage not zoned agricultural

## Special Designations

N000	This 4-digit designation shall be placed in the data processing record in the use code field for records that are printed as notes on the roll.
H000	This 4-digit designation shall be placed in the data processing record in the use code field for records that are printed as headings on the roll.

### (d) Definitions:

1. Classified use assessments shall be those valuations determined pursuant to Article VII, Section 4(a), Constitution of State of Florida.

*Specific Authority 195.027(1), 213.06(1) FS. Law Implemented 195.027, 195.073, 195.084, 213.05 FS. History--New 12-7-76, formerly 12D-8.08, Amended 12-27-94, 12-25-96, 12-30-02.*

In addition to the commonly used abbreviations and property use codes discussed in Section 12D-8.008 of the Florida Administrative Code there are minimum data requirements covered under Section 12D-8.011 of the Florida Administrative Code.

## **12D-8.011 Uniform Standards for Computer Operations: Minimum Data Requirements.**

(1) Each property appraiser shall maintain the following data in one or more of his or her data processing files regarding each parcel of real estate in his or her county.

(a) A unique parcel number based on a parcel numbering system applied uniformly throughout the county.

(b) A code indicating the taxing authorities whose jurisdiction includes this parcel.

(c) Data indicating the location of the parcel. This data may be a part of items (a) and/or

## Interpretation of Real Property Descriptions

---

(b) above. The data shall indicate:

1. Township.
2. Range.
3. Section number or grant number.
4. Subdivision code or number, if applicable.
5. Municipality code or number, if applicable.

(d) Owner's or Fiduciary's name.

(e) Owner's or Fiduciary's mailing address.

1. Address.
2. Zip Code. All address information entered in the file prior to the adoption of this rule need not show zip code as a separate field.

(f) Basic land information:

1. Land Use Code. This code shall be as defined under paragraph 12D-8.008(2)(c), F.A.C.
2. A code indicating the unit of measurement used as the basis of assessment of the land. The property appraiser may continue to use any existing codes provided they are translated to the following when submitted to the Department:
  - a. 1 = per acre;
  - b. 2 = per square foot;
  - c. 3 = per front foot or per effective front foot (all lots with typical depth);
  - d. 4 = per front foot or per effective front foot (all lots with non-typical depth);
  - e. 5 = per lot or tract;
  - f. 6 = combination of any of the above;
3. The number of units of land. One of the following items shall be shown, corresponding to subparagraph (f)2. above.
  - a. The number of acres;
  - b. The number of square feet;
  - c. The number of front feet or effective front feet and the depth in feet (when depth is available);
  - d. The number of front feet or effective front feet and the effective depth in feet (when

## Interpretation of Real Property Descriptions

---

depth is available);

- e. The number of lots or tracks;
- f. Break-down of the number of combined units if available.

(g) Basic building information:

1. The year built or the effective year built of the main improvement. The appraiser shall consistently maintain one or the other (or both) years for every improved parcel in the county.

2. The total living area or the total adjusted area of the main improvement on improved residential property, or the total usable area for non-residential improved property.

The appraiser shall consistently maintain total living area or total adjusted area (or both) for every improved residential parcel in the county.

3. A code indicating the principal type of construction of the exterior walls of the main improvement on each improved parcel. The property appraiser may continue to use any existing codes provided they are translated to the following when submitted to the Department:

- 01 – Wall Board;
- 02 – 8-Inch Brick;
- 03 – Metal;
- 04 – Asbestos Shingles on Frame;
- 05 – Stucco on Frame;
- 06 – Siding – No Sheathing;
- 07 – Concrete Block;
- 08 – Corrugated Asbestos;
- 09 – Stucco on Concrete Block (C. B. S.);
- 10 – Stucco on Tile;
- 11 – Siding – with Sheathing;
- 12 – Brick Veneer on Frame;
- 13 – Brick Veneer on Masonry;
- 14 – Aluminum Siding;
- 15 – 12-Inch Brick;

## Interpretation of Real Property Descriptions

---

- 16 – Reinforced Concrete;
- 17 – Metal on Steel;
- 18 – Wood Shingles;
- 19 – Jumbo Brick;
- 20 – Tilt-up Concrete Slabs;
- 51 – Brick on Masonry Down-Wood Siding Up;
- 52 – Brick on Masonry Down-Asbestos Shingles Up;
- 53 – Wood Siding Down-Asbestos Shingles Up;
- 54 – Stone on Masonry Down-Wood Siding Up;
- 55 – Concrete Block Plain Down-Asbestos Shingles Up;
- 56 – Concrete Block Plain Down-Wood Siding Up;
- 57 – Brick on Frame Down-Wood Siding Up.

NOTE: If the property appraiser maintains a master appraisal system, at the time of adoption of these rules and regulations, which system utilizes “Points”, “Construction Units” or other numerical designation, in lieu of a code, to indicate principal type of exterior wall construction, then such “Points”, “Construction Units” or other numerical designation, may be submitted in lieu of the codes indicated hereinabove; provided, however, that a schedule showing the number of “Points”, “Construction Units” or numbers used for each type of exterior wall construction is also submitted to the Department.

- (h) Land Value – Just Value (Section 193.011, F.S.) or classified use value, if applicable.
- (i) Total just value (land just value plus building value).
- (j) Total assessed value (land classified use value plus building value or total just value for non-classified use parcels).
- (k) Taxable value for operating purposes.
- (l) New construction value. This amount shall be included in the value shown for Items (i) through (l). Deletions shall be shown as a negative amount.
- (m) The following information shall be gathered and posted for the two most recent transfers of each parcel. Only information on transfers occurring after December 31, 1976, needs to be gathered and posted.
  - 1. Date of execution of instrument (month and year).

## Interpretation of Real Property Descriptions

---

2. Official Record (“O.R.”) Book and Page number – These shall be recorded as entries separate from the property description so that a computer sort on this information is possible.

3. A transfer code denoting certain characteristics of the transfer. A transfer should be considered for disqualification if any of the following apply:

Corrective deed, quit claim deed, or tax deed; Deed bearing Florida Documentary Stamp at the minimum rate prescribed under Chapter 201, F.S.;

Deed bearing same family name as to Grantor and Grantee;

Deeds to or from banks, loan or mortgage companies;

Deeds conveying cemetery lots or parcels;

Deeds including unusual amounts of personal property;

Deeds containing a reservation of occupancy for more than 90 days (life estate interest);

Deeds involving a trade or exchange of land;

Deeds where the consideration is indeterminable;

Deed conveying less than a half interest;

Deeds to or executed by any of the following:

a. Administrators;

b. Benevolent Institutions;

c. Churches;

d. Clerk Commissioners;

e. Clerk of Courts;

f. Counties;

g. Educational Institutions;

h. Executors;

i. Federal Agencies;

j. Federal Government;

k. Fraternal Institutions;

## Interpretation of Real Property Descriptions

---

- l. Guardians;
- m. Lodges;
- n. Masters;
- o. Municipalities;
- p. Receivers;
- q. Sheriffs;
- r. State Board of Education;
- s. Trustees in Bankruptcy;
- t. Trustees of the Internal Improvement Trust Fund (or Board of Natural Resources);
- u. Utility Companies. The property appraiser may continue to use any existing codes provided they are translated to the following when submitted to the Department:
  - 00. Sales which are qualified;
  - 01. Sales which are disqualified as a result of examination of the deed;
  - 02. Deeds which include more than one parcel;
  - 03. Other disqualified.
  - 4. Sales prices as indicated by documentary stamps.
  - 5. Wherever possible, a one-digit code indicating whether the parcel was improved (I) or vacant (V) at the time of sale.
- (n) Property description or map number. Map number is allowable in lieu of property description if a map reference number and Official Record (“O.R.”) Book and Page number is printed on the roll for each parcel.
- (o)1. Exemption type. A code indicating the type of exemption granted to the parcel and the value(s) thereof. The property appraiser may continue to use any existing codes provided they are translated to the codes prescribed when submitted to the Department. The code is as follows:
  - A – Senior Homestead Exemption (Section 196.075, F.S.)
  - B – Blind (Section 196.202, F.S.)

## Interpretation of Real Property Descriptions

---

- C – Charitable, Religious, Scientific or Literary (Sections 196.196, 196.1987, F.S.)
- D – Disabled (Sections 196.081, 196.091, 196.101, F.S.)
- E – Economic Development (Section 196.1995, F.S.)
- G – Federal Government Property (Section 196.199(1)(a), F.S.); State Government Property (Section 196.99(1)(b), F.S.); Local Government Property (Section 196.199(1)(c), F.S.); Leasehold Interests in Government Property (Section 196.199(2), F.S.)
- H – Historic Property (Section 196.1997, F.S.)
- I – Historic Property Open to the Public (Section 196.1998, F.S.)
- L – Labor Organization (Section 196.1985, F.S.)
- M – Homes for the Aged (Section 196.1975, F.S.)
- N – Nursing Homes, Hospitals, Homes for Special Services (Section 196.197, F.S.)
- O – Widowers (Section 196.202, F.S.)
- P – Totally and Permanently Disabled (Section 196.202, F.S.)
- Q – Combination (Homestead, Disabled, Widow, Widower, Totally and Permanently Disabled, Senior Homestead Exemption - Sections 196.031, 196.075, 196.202, F.S.)
- R – Renewable Energy Source (Section 196.175, F.S.)
- S – Sewer and Water Not-for-Profit (Section 196.2001, F.S.)
- T – Community Centers (Section 196.1986, F.S.)
- U – Educational Property (Section 196.198, F.S.)
- V – Disabled Veteran/Spouse (Section 196.24, F.S.)
- W – Widows (Section 196.202, F.S.)
- X – Homestead Exemption (Section 196.031, F.S.)
- Y – Combination (Homestead, Disabled, Widow, Widower, Totally and Permanently Disabled, Disabled Veteran, Senior Homestead Exemption – Sections 196.031, 196.075, 196.202, 196.24, F.S.)
- Z – Combination (Renewable Energy Source, Economic Development – Sections 196.175, 196.1995, F.S.)



# Interpretation of Real Property Descriptions

---

- 1 – Licensed Child Care Facility Operating in Enterprise Zone (Section 196.095, F.S.)
- 2 – Historic Property Used for Certain Commercial or Nonprofit Purposes (Section 196.1961, F.S.)
- 3 – Proprietary Continuing Care Facilities (Section 196.1977, F.S.)
- 4 – Affordable Housing Property (Section 196.1978, F.S.)
- 5 – Charter School (Section 196.1983, F.S.)
- 6 – Public Property Used Under License or Lease Agreement Entered into Prior to January 1, 1969 (Section 196.1993, F.S.)
- 7 – Space Laboratories and Carriers (Section 196.1999, F.S.)
- 8 – Water and Wastewater Systems Not-for-Profit (Section 196.2002, F.S.)
- 9 – Contiguous multiple parcels with a single homestead exemption or single parcels with multiple homestead exemptions

2. Personal exemption codes shall be “0” (zero) indicating the exemption does not apply or the applicable code provided in this rule subsection indicating an exemption does apply. Five of six personal exemptions may apply for each parcel, in the following order.

Exemption Type	Maximum Value	Code
Homestead	\$25,000	X
Widowed	\$500	W/O
Blind	\$500	B
Disabled	\$500	P
Veteran Disabled/Spouse	\$10,000	V
Disabled (100 percent Exempt)	–	D

An individual who qualified for the \$25,000 exemption may also be entitled to the \$500 exemption of section 3(b), Art. VII, State Const. (for widows, widowers, or blind or totally and permanently disabled persons) and Section 196.202, F.S., and/or the \$5,000 exemption under Section 196.24, F.S. (disabled veterans/spouse). In no event shall the aggregate exemption exceed \$26,500 (see Rule 12D-7.003(2), F.A.C.) for individuals exempt under Section 196.202, F.S., or \$36,000 (see Rule 12D-7.003(2), F.A.C.) for individuals exempt under Section 196.24, F.S., except for total exemptions under Sections 196.081, 196.091, or 196.101, F.S.

## Interpretation of Real Property Descriptions

---

(p) A code indicating the type of special assessment applicable to the parcel. The property appraiser may continue to use any existing codes provided they are translated to the following when submitted to the Department:

0 – None;

1 – Pollution Control Device(s);

2 – Land subject to a conservation easement, environmentally endangered lands, or lands used for outdoor recreational or park purposes when land development rights have been conveyed or conservation restrictions have been covenanted;

3 – Land subject to a moratorium.

(q) In the event that the county has completely or partially changed parcel numbering since the previous roll, an “alternate key” which will allow a translation of individual parcel numbers from those used on the previous roll to those used on the current roll. This shall not be construed to apply to routine renumbering resulting from splits, deletions and combinations of parcels.

(2) Each property appraiser shall maintain the following data in one or more of his/her data processing files regarding each personal property account in his/her county.

(a) County Code. This is a number assigned to each county for identification purposes. Alachua County is assigned number 11, each successive county in alphabetical order is assigned a number increased by 1, with Washington County assigned number 77.

(b) Personal Property account number. This number may be used as the cross-reference to the return as filed.

(c) Taxing Authority Code. A code indicating the taxing authorities in whose jurisdiction the property is located. Same basic code as is used for real property.

(d) Roll Type. “P” for personal.

(e) Roll Year. The last two digits of the tax year.

(f) Class Code. A code, as defined in paragraph 12D-8.009(2)(c), F.A.C., indicating the classification of the property.

(g) Furniture, Fixtures, and Equipment; Materials and Supplies, at Just Value.

(h) Leasehold improvements at Just Value. Any improvements, including modifications and additions, to leased property.

## Interpretation of Real Property Descriptions

---

(i) Pollution Control Devices at Just Value.

(j) The Taxable Value, (Salvage Value) of these pollution control devices.

(k) Total Just Value. The sum of the just values of: furniture, fixtures, and equipment; taxable household goods; material and supplies; leasehold improvements; and pollution control devices.

(l) Total Exemption Value. The total value of any exemption granted to the account.

(m) Exemption Type. A code indicating the type of exemption granted the account. The code is as follows:

A – Institutional (Sections 196.195, 196.196, 196.197, F.S.);

B – Non-Governmental Educational Property other than under Section 196.1985, F.S. (Section 196.198, F.S.);

C – Federal Government Property (Section 196.199(1)(a), F.S.);

D – State Government Property (Section 196.199(1)(b), F.S.);

E – Local Government Property (Section 196.199(1)(c), F.S.);

F – Leasehold Interests in Government Property (Section 196.199(2), F.S.);

G – Economic Development (Section 196.1995, F.S.);

H – Not-for-profit Sewer and Water Companies (Section 196.2001, F.S.);

I – Blind Exemption (Section 196.202, F.S.);

J – Total and Permanent Disability Exemption (Section 196.202, F.S.);

K – Widow's Exemption (Section 196.202, F.S.);

L – Disabled Veteran's Exemption (Section 196.24, F.S.)

(n) Total Taxable Value. The total just values (k), above less the total exemption value (l), above.

(o) Penalty Rate as Applicable.

(p) Taxpayer Name.

(q) Mailing Address of the Taxpayer.

## Interpretation of Real Property Descriptions

---

- (r) City.
  - (s) State or Country (including zip code).
  - (t) Street Address. Where the property is physically located.
  - (u) City. Where the property is physically located.
  - (v) In the event that the county has completely or partially changed account numbering since the previous roll, an “alternate key” which will allow a translation of individual account numbers from those used on the previous roll to those used on the current roll. This shall not be construed to apply to routine renumbering resulting from attrition or addition of accounts.
  - (w) Tax Roll Sequence Number. A number to be assigned in the order accounts appear on the assessment roll.
- (3) If the property appraiser establishes a Master Appraisal File, the M.A.F. Cost shall include, but shall not necessarily be limited to, the following information for the main improvements to each parcel. Codes may be used where applicable.
- (a) Year built or effective year built.
  - (b) Exterior wall type.
  - (c) Roof type.
  - (d) Roof material.
  - (e) Floor type.
  - (f) Interior walls.
  - (g) Electrical features/quality, if available.
  - (h) Number of plumbing fixtures or number of baths.
  - (i) Heating.
  - (j) Air-conditioning.
  - (k) Base area.
  - (l) Adjusted area, if applicable.
  - (m) Overall condition or depreciation factor.

## Interpretation of Real Property Descriptions

---

(n) An indication of each extra feature and detached subsidiary buildings and the value ascribed thereto.

NOTE: If the property appraiser maintains a Master Appraisal File, at the time of adoption of these rules and regulations, which file contains “Classes of Buildings” to indicate a combination of two or more of the construction features shown above, then such “Classes” may be submitted in lieu of those specific construction features shown above which are included in the “Class” of the building.

If the property appraiser maintains a Master Appraisal File, at the time of adoption of these rules and regulations, which file utilizes “Points” or “Construction Units” to indicate exterior wall type or combination of exterior wall types, then such “Points” or “Construction Units” may be submitted when specific exterior wall type required under paragraph (b) above is not otherwise available.

(4) When a property appraiser’s upcoming roll will be subjected to an in-depth review pursuant to Section 195.096, F.S., when requested by the Department he should maintain the following data in one or more of his data processing files or on a written list for each real property parcel which was deleted from the prior year’s roll, which was split from a parcel on the prior year’s roll, or which was combined with a parcel from the prior year’s roll.

- (a) Unique parcel number of the parcel which has been deleted, split off, or combined.
- (b) Land use code applicable to the parcel listed under paragraph (a).
- (c) A code indicating whether the parcel was deleted (1), split from (2), or combined with another parcel (3).
- (d) Values – The values shall be those shown on the previous year’s roll if deletion; the values shall be those shown on the current year’s roll if split or combination.
  - 1. Just Value (for non-classified use parcels).
  - 2. Classified use value (for classified use parcels).
  - 3. Total Taxable Value.
- (e) Parent Parcel Number, if entry applies to a split.
- (f) Land Use Code applicable to the parcel listed under paragraph (e).

*Specific Authority 195.027(1), 213.06(1) FS. Law Implemented 195.027, 196.031, 196.075, 196.081, 196.091, 196.101, 196.175, 196.195, 196.196, 196.197, 196.1975, 196.198, 196.1985, 196.1986, 196.1987, 196.199, 196.1995, 196.1997, 196.1998, 196.2001, 196.202, 196.24, 213.05 FS. History– New 12-7-76, Amended 9-30-82, Formerly 12D-8.11, Amended 12-31-98, 12-30-02, 1-1-04, 10-2-07.*

# Interpretation of Real Property Descriptions

---

## 12D-1.009 Mapping Requirements

(1) Each county property appraiser shall have and maintain the following:

(a) Aerial photography suitable for the needs of his office.

(b) Property ownership maps which will reflect the following:

1. Recorded subdivisions and/or unrecorded subdivisions, if being used for assessing, in their entirety on the property ownership maps including lot and block division and dimensions if known.

2. Dimensions and acreage, where known, on all parcels over one acre in size.

3. Parcel number (normally the last four digits of the property identification number).

(2) Suggested procedures for establishing and maintaining an adequate cadastral mapping program to meet these requirements are contained in the mapping guidelines of the Department of Revenue's Manual of Instructions.

*Specific Authority 193.085(2), 195.027(1), 213.06(1) FS. Law Implemented 195.022, 195.062, 213.05 FS. History-New 10-12-76, Formerly 12D-1.09.*

## **Florida Statutes Cadastral Mappers should be aware of:**

<a href="#">F.S. 95.16</a>	Real property actions; adverse possession under color of title
<a href="#">F.S. 95.18</a>	Real property actions; adverse possession without color of title
<a href="#">F.S. 95.361</a>	Roads presumed to be dedicated
<a href="#">F.S. 177</a>	Land Boundaries, subsections 177.011-177.151 ( <b>Platting</b> )
<a href="#">F.S. 192.011</a>	All property to be assessed
<a href="#">F.S. 192.032</a>	Situs of property for assessment purposes
<a href="#">F.S. 193.011</a>	Factors to consider in deriving just valuation
<a href="#">F.S. 193.085</a>	Listing all property
<a href="#">F.S. 193.114</a>	Preparation of assessment rolls
<a href="#">F.S. 195.002</a>	Supervision by Department of Revenue
<a href="#">F.S. 195.022</a>	Forms to be prescribed by Department of Revenue
<a href="#">F.S. 195.027</a>	Rules and regulations
<a href="#">F.S. 195.062</a>	Manual of instructions
<a href="#">F.S. 197.192</a>	Land not to be divided or plat filed until taxes paid
<a href="#">F.S. 253</a>	State Lands
<a href="#">F.S. 689-723</a>	Title XL - Real and Personal Property - which include the following:
<a href="#">F.S. 689</a>	Conveyances of Land and Declarations of Trust
<a href="#">F.S. 695</a>	Record of Conveyances of Real Estate
<a href="#">F.S. 704</a>	Easements (there is always a right to get to your parcel when it is landlocked)
<a href="#">F.S. 718</a>	Condominiums

<http://www.leg.state.fl.us/Statutes/index.cfm?Mode=Constitution&Submenu=3&Tab=statutes>

## Interpretation of Real Property Descriptions

---

### **F.S. 689      Conveyances of Land and Declarations of Trust**

This statute covers how real estate is conveyed, conveyances to or by partnerships, declarations of trust, entailed estates, how trust estate is conveyed, etc. Also included in is F.S. 689.071 covering the Florida Land Trust Act.

### **F.S. 695      Record of Conveyances of Real Estate**

This statute covers the recordation of documents, witnesses, defects as to acknowledgments and witnesses, use of scrawl as seal, recording conveyances lost by fire, examples of short form acknowledgments, and the validity of recorded electronic documents.

*\*\*\*Note: It is good practice to keep a hyperlink to the information in this section rather than a paper or static digital copy. You need to make sure you have the most up to date information!*

**State of Florida**

**Cadastral Mapping**  
**Guidelines**

Compiled by the:

**Florida Department of Revenue**  
**Property Tax Administration**  
**Mapping & GIS Section**

In cooperation with the:  
**Florida Geographic Information Board**



# Interpretation of Real Property Descriptions

---

## **Table of Contents**

### **1.0 Introduction**

- 1.1 Applicability
- 1.2 Staffing and Training

### **2.0 Base Map Development**

- 2.1 Paper to Digital Conversion
- 2.2 Outsource

### **3.0 Accuracy**

- 3.1 Benefits
- 3.2 Control
- 3.3 Horizontal Accuracy
- 3.4 Scale Mixing

### **4.0 Projections & Coordinate Systems**

- 4.1 Florida Coordinate Systems (1927 and 1983 datums)
- 4.2 Latitude - Longitude (Geographic)
- 4.3 Universal Transverse Mercator (UTM)
- 4.4 Transverse Mercator Projection
- 4.5 Lambert Conformal Conic Projection

### **5.0 Cartography**

- 5.1 North Arrow
- 5.2 Scale Representation
- 5.3 Map Date
- 5.4 Title Block
- 5.5 Disclaimer
- 5.6 Lines and Other Delineations
  - 5.6.1 Public Land Survey System Lines (PLSS)/Land Grant Lines
  - 5.6.2 Parcel Lines
  - 5.6.3 Lot Lines
  - 5.6.4 Block Lines
  - 5.6.5 Easement Lines
  - 5.6.6 Right-of-Way Lines
  - 5.6.7 Hydrographic Lines
- 5.7 Annotation
  - 5.7.1 Acreage
  - 5.7.2 Dimensions
  - 5.7.3 Lot Numbers
  - 5.7.4 Block Numbers
  - 5.7.5 Street, Road, Right-of-Way Names
  - 5.7.6 Subdivision and Condominium Names
  - 5.7.7 Easements
  - 5.7.8 Parcel Numbers

### **6.0 Map Compilation**

- 6.1 Assembling Source Data
- 6.2 Constructing a Framework for the Parcel Maps
- 6.3 Compiling the Boundaries of Parcels

# Interpretation of Real Property Descriptions

---

6.3.1 Map Boundary Compilation Issues

## **7.0 Map Maintenance**

7.1 Updating

7.2 Quality Control

## **8.0 Land Descriptions**

8.1 Interpretation

8.2 Abbreviation

8.3 Condensing Descriptions

## **9.0 Land Description Conflicts and Solutions**

9.1 Double Assessment

9.2 Omitted Areas

9.3 Parcel in Vacated Portion of Plat

9.4 Government Lots

9.5 Islands

9.6 Addressing Erroneous Descriptions

## **10.0 Parcel Numbering**

## **11.0 Data Archival**

## **12.0 Data Exchange Standards**

12.1 Native and Direct Data Exchange Formats

12.2 Common Data Exchange Formats

12.3 Data Exchange Media

## **13.0 Metadata**

13.1 Federal Geographic Data Committee (FGDC) Metadata Standards

## **14.0 Data Base Design**

14.1 Logical Model for Tax Parcel Geometry and Tabular Data

14.2 Logical Model for Tax Parcel Boundary Geometry

14.3 Logical Model for Tax Parcel Legal Area Description

## **15.0 Glossary of Terms**

## **Appendix A - Layers in Geographic Information System**

## **Appendix B - National Map Accuracy Standards**

## **Appendix C - State Plane Coordinate Zones of Florida**

## **Section 1**

### **1.0 Introduction**

The principal responsibility of the county property appraiser is to locate, inventory, and appraise all property within the jurisdiction. A complete set of maps is necessary to perform this function. Maps help determine the location of property, indicate the size and shape of each parcel, and reveal geographic relationships that affect property value. Maps and map data are important not only for property appraisers, but for other agencies and individuals.

To make maximum use of data on land parcels, it is desirable for jurisdictions to try to develop a multipurpose cadastre. A multipurpose cadastre furnishes a framework to

# Interpretation of Real Property Descriptions

---

record, store, and provide comprehensive land information at the parcel level, and makes it possible to share parcel data among all users of the data.

A multipurpose cadastre should have the following components: a series of current, accurate, large-scale photogrammetric base maps that are tied to a geodetic network; cadastral overlays delineating all real property parcels; a unique identifier assigned to each parcel that is used as a common index to all land records; and a series of land files each containing the parcel identifiers in addition to other data.

Any jurisdiction that undertakes a cadastral mapping program should work with other agencies to establish a multipurpose cadastre.<sup>1</sup>

These guidelines have been compiled by the Florida Department of Revenue, Property Tax Administration Program, Mapping & GIS Section to provide direction and assistance to the county property appraisers of the state.

## 1.1 Applicability

These guidelines apply to all county property appraisers or any other agency, institution, or corporation engaged in the preparation of maps for purposes as specified in Chapter 193.085 FS. Portions of these guidelines are practical only in a digital environment. Currently operating map programs which are technically or structurally unable to comply are not required to retrofit to these guidelines, but are encouraged to implement as many of these guidelines as soon as possible.

## 1.2 Staffing and Training

An effective mapping program requires adequate staff support. Staffing needs will depend on the type of mapping system and the size of the jurisdiction. All mapping personnel should receive training in procedures that are appropriate to the jurisdiction.<sup>2</sup> In addition to traditional cadastral mapping skills and knowledge such as drafting, photogrammetry, and land transfer principles, among others, it may be desirable that personnel should also be capable of performing system analysis and design, database management, network administration, and computer operations. Adequate resources should be allocated to ensure that new and existing personnel receive appropriate periodic training.

## Section 2

### 2.0 Base Map Development

A base map is a geometric control feature in a digital mapping system that permits many other specialized theme layers to be brought into absolute position by registration on the base map (See Appendix A). There are three general themes or layers of base map content that will permit registration of most other themes or layers: boundaries, roads,

<sup>1</sup> International Association of Assessing Officers (IAAO), Standard on Cadastral Maps and Parcel Identifiers, 1988

<sup>2</sup> International Association of Assessing Officers, (IAAO) Standards on Cadastral Maps and Parcel Identifiers, 1988

---

# Interpretation of Real Property Descriptions

---

and water features. Boundaries can be divided into three classes: public land survey boundaries, parcel boundaries, and political boundaries.

## 2.1 Paper to Digital Conversion

Any approach to remapping should begin with a determination of the desired outcome of the project based on user needs and accuracy requirements prior to hardware and software purchases. Quality control measures should be implemented throughout the course of the project. There are several methods of converting paper maps to the computer. Each method must follow these fundamental principles to be successful. The alternatives of scanning, board digitizing and coordinate geometry must be evaluated to determine the most desirable method to be employed for each portion of a mapping project. Most mapping strategies will probably use a combination of conversion methods to effect the optimum conversion strategy for an entire project. Care should be taken to plan each project with adequate time and resources to ensure a final product that will meet the standard of accuracy determined for the project.

1. The source document must be of usable quality.
  - a. Legible or restorable.
  - b. Accurate in scale and direction.
  - c. There are adequate sources to cover the area mapped.
  - d. Source documents are accessible and available.
  
2. There is adequate control to locate the map in the real world.
  - a. The frequency of the control ensures that all map portions are fitting properly.
  - b. The dispersion of the control ensures that there is no distortion in areas of difficult fits.
  - c. Controlled photos of project area should be inventoried and evaluated for use.
  - d. All existing digital coverage should be inventoried and evaluated for control potential.

3. Coordinate geometry (COGO) should be implemented as much as possible to ensure consistency between recorded instruments, as built designs, other available digital maps, and the base map. Although coordinate geometry is usually regarded as the most accurate method of base map construction, it is sound practice to integrate the COGO work with existing reliable digital sources to ensure accuracy and consistency and minimize the expense and effort of the duplication of existing digital work. When inconsistencies between the property records and other mapping sources (i.e.: photo evidence) appear, a thorough investigation should be initiated to discover all the relevant evidence to make the judgement for locating the element on the map accurately. The recorded instrument remains the authoritative record upon which all property valuations must rely. If the record conflicts with the evidence of the map, the recourse for the mapper is to identify the discrepancy for reconciliation by the proper authorized parties.

# Interpretation of Real Property Descriptions

---

4. Hardware and software should be evaluated and chosen that will implement the conversion successfully.
  - a. Scanners should be of adequate resolution to convert source documents to a pixel size that will support desired accuracy.
  - b. Scanners should support an adequate number of shading levels to reproduce the detail of the original document to the screen.
  - c. Scanners should be of adequate size to accommodate source material with a minimum of cutting or folding.
  - d. Digitizer resolution should support accuracy required.
  - e. Computer processing and storage must have the capacity to process and store large raster files.
  - f. The video adapter and monitor of the system must allow clear viewing of digitized materials.
  - g. The software employed must offer adequate manipulation tools to capture and enhance source documents.
  - h. The software employed must be friendly enough to ensure consistent, accurate use by trained operators.
  - i. Software employed must provide all the tools required to ensure accurate fitting of digitized source to project.
  - j. Software employed should facilitate quality control procedures.
5. Operators are trained and follow sound conversion procedures.
6. Quality control is frequent and thorough.

## **2.2 Outsource**

Several vendors are available who can provide services ranging from technical assistance to turn-key systems, complete with periodic updates of map changes. Costs vary depending on the approach to conversion and the level of service provided. Careful consideration should be given to the costs and services provided, as well as ultimate ownership and use of the data generated. An in-house quality control program is essential to ensure that the product delivered is according to predetermined specifications.

## **Section 3**

### **2.0 Accuracy**

Map accuracy is the degree toward which any given feature(s) on a map conforms to its true position on the ground.

### **3.1 Benefits**

The direct benefit of map accuracy is to ensure accurate spatial representation of mapped features not only on cadastral maps, but also for features included in other map themes such as those used for planning, permitting, routing and emergency services. Accurate cadastral maps aid property appraisers in the determination of equitable assessments throughout the jurisdiction.

# Interpretation of Real Property Descriptions

---

## 3.2 Control

A base map consists of geometrically controlled features in digital mapping system that permits many specialized theme layers to be brought into absolute position by registration on the base map. A base map that would support property appraisal has three base components (Geodetic Control, Public Land Survey System, and Parcel Boundary) that permit the overlaying of other themes: boundaries, roads, and water features.

## 3.3 Horizontal Accuracy

Horizontal accuracy should meet or exceed U.S. National Map Accuracy Standards (NMAS). NMAS are reproduced in Appendix B of this document. Note, however, that adherence to NMAS can usually be achieved only when maps are compiled directly by survey, GPS, and/or photogrammetric methods.

U.S. National Map Accuracy Standards require that at scales of 1:20,000 and larger (for example, 1:12,000, 1:1,200) that 90% of a randomly chosen sample of well-defined map features will be on the map within 1/30 inch (0.03 inches) (at scale) of their true location on the ground. The table below illustrates the positional accuracy of several relevant scales.

### Scale Horizontal Accuracy

1:1,200 + or - 3.33 feet
1:2,400 + or - 6.67 feet
1:4,800 + or - 13.33 feet
1:9,600 + or - 26.67 feet
1:10,000 + or - 27.78 feet
1:12,000 + or - 33.33 feet

## 3.4 Scale Mixing

The mixing of digital map data of widely divergent scales into a common database should be avoided, as the positional accuracy of the aggregate database would be considered to be no better than that of the smallest scale.

## Section 4

### 4.0 Projections and Coordinate Systems

The following projections and coordinate systems are recommended for the input, storage, and in particular, the exchange of digital map data. It is recommended that cadastral maps in Florida be based upon state plane coordinates adjusted to the 1983 (1990 readjustment) horizontal datum. Other projections and coordinate systems may be used to satisfy special requirements.

#### 4.1 Florida Coordinate Systems (1927 and 1983 datums)

The Florida Coordinate Systems, 1983/90 datum, in which map distortion has been minimized by dividing the state into three zones (See Appendix C) must, by state law, be used for surveying and the compilation of engineering maps. These systems may also be

# Interpretation of Real Property Descriptions

---

used for the compilation of regional maps, but since they do not provide uninterrupted coverage of the entire state, such mapping should not extend beyond the limits of any given zone. These systems may be used for the input, storage, and exchange of digital map data, as well as for the output of hardcopy maps.

## **4.2 Latitude - Longitude (Geographic)**

Latitude - Longitude is a projectionless coordinate system that may be used for the input, storage, and exchange of digital map data. Although it may also be used for the output of hardcopy maps, it is not structurally suited for that purpose.

## **4.3 Universal Transverse Mercator (UTM)**

The Universal Transverse Mercator map projection system may be used for regional mapping, but like the State Plane Coordinate Systems, such mapping should not extend beyond the limits of any given zone. This system may be used for the input, storage, and exchange of digital map data, as well as for the output of hardcopy maps.

## **4.4 Transverse Mercator Projection**

The Transverse Mercator map projection is based on an imaginary cylinder covering the area of interest. This projection is best for areas that lie in a north-south direction such as the Florida peninsula. This system may be used for the input, storage, and exchange of digital map data, as well as for the output of hardcopy maps.

## **4.5 Lambert Conformal Conic Projection**

Lambert projects an imaginary cone to cover the area of interest and has greater east-west integrity than north-south such as the Florida panhandle area. This system may be used for the input, storage, and exchange of digital map data, as well as for the output of hardcopy maps.

## **Section 5**

### **5.0 Cartography**

Map design considerations determine whether a map is legible and easily interpreted. The following cartographic elements should appear on all cadastral maps in order to facilitate functionality, while other elements may be included as optional according to local needs or resources.

#### **5.1 North Arrow**

An arrow-like symbol indicating the direction to which the control framework of a map or drawing is referenced.

#### **5.2 Scale Representation**

Since maps must necessarily be smaller than the areas mapped, their use requires that the ratio or proportion between comparable measurements be expressed on the map. This is called map scale and should be the first thing of which the map user becomes aware.<sup>3</sup> Scale should be expressed as a statement of map distance in relation to earth distance or a graphic (or bar) scale or both.

# Interpretation of Real Property Descriptions

---

## 5.3 Map Date

The actual date the map was plotted should be prominently displayed.

## 5.4 Title Block

A title block may include such items as county and state names, scale, north arrow, legend, plot date, disclaimer, and map index, among others.

## 5.5 Disclaimer

Disclaimers are used to limit and define the map author's responsibility for the content, accuracy, and currency of a map. Although some maps may require specialized disclaimers, the following disclaimer represents one suggestion:

"This map is the product of *Agency*, *Division* and was printed on *Date*. This map was produced with the intent that it be used for *Purpose* at the scale of *X*. There are no warranties made as to the fitness of this map for any unlisted purpose or reproduction at any other than the original scale."

The agency can complete the italicized sections with appropriate information relating to the agency and the purpose of the map.

## 5.6 Lines and Other Delineations

Certain lines are basic and are expected to appear on any cadastral map. Significance of some lines may be distinguished by line weight.

### 5.6.1 Public Land Survey System Lines (PLSS)/Land Grant Lines

Rule 12D-8.008, (1), (a), Florida Administrative Code, requires all descriptions (and thus parcel maps) to be based upon reference to the government grid survey system.

### 5.6.2 Parcel Lines

Parcel, or boundary lines of all assessed property. Parcel lines may include the following line types: subdivision, block, right-of-way, hydrographic.

### 5.6.3 Lot Lines

All recorded subdivision lot lines, except that when said lines are not coincident with parcel boundary lines they may be displayed as "broken lines" and/or maintained in a separate layer.

### 5.6.4 Block Lines

Recorded subdivision block lines.

3 Elements of Cartography, Fourth Edition, John Wiley & Sons Inc., 1978, pg. 46



---

# Interpretation of Real Property Descriptions

---

## **.7.1 Easement Lines**

All easement lines that present a significant influence on property value should be displayed. A significant influence on property value may occur in the presence of an easement that is not general or common to all properties (i.e. conservation easements, drainage easements, and ingress and egress or right-of-way easements).

## **.7.2 Right-of-Way Lines**

Road, utility, and railroad right-of-way lines form parcel boundaries.

## **.7.3 Hydrographic Lines**

Water boundaries (i.e. seas, lakes, streams, rivers) forming parcel boundaries, or where significant to value.

## **5.7 Annotation**

Lettering a map means the preparation of this aspect of the artwork, which includes all the names, numbers, and other typographical material. <sup>4</sup> Procedures for the placement and size of annotation should be developed by each jurisdiction. Accurate interpretation of a map is dependent upon the annotation placed thereon. Certain elements of annotation are expected to appear on any cadastral map.

### **1.7.1 Acreage**

Rule 12D-1.009, Florida Administrative Code states that all acreage of parcels over one acre in size, where known, are to be reflected on the map. Where known as used in the rule means acreage from instruments of title as are usually recorded in the public records of the county.

### **1.7.2 Dimensions**

Rule 12D-1.009, Florida Administrative Code states that all dimension of parcels over one acre in size, where known, are to be reflected on the map. Where known as used in the rule means dimensions from instruments of title as are usually recorded in the public records of the county.

### **1.7.3 Lot Numbers**

Numbers of all recorded subdivision lots, all Government Lots, and where applicable, numbers of lots in "unrecorded subdivisions".

### **1.7.4 Block Numbers**

Numbers of blocks in all recorded subdivisions and where applicable, numbers of blocks in "unrecorded subdivisions".

<sup>4</sup> Elements of Cartography, Fourth Edition, John Wiley & Sons, Inc., 1978

---

# Interpretation of Real Property Descriptions

---

## **1.7.5 Street, Road, Right-of-Way Names**

Names and/or route numbers of streets, roads, and rights-of-way forming parcel boundaries.

## **1.7.6 Subdivision and Condominium Names**

Names or reference codes of all subdivisions and condominiums. Where only reference codes are utilized it is suggested that an associated legend be shown.

## **1.7.7 Easements**

Where easements are shown it is recommended that the type of easement be displayed.

## **1.7.8 Parcel Numbers**

See Section 10 of this document.

## **Section 6**

### **6.0 Map Compilation**

Five major tasks need to be considered when actually developing a parcel map system.<sup>5</sup>

These tasks include:

1. Assembling and weighting source data
2. Constructing a framework for the parcel maps
3. Compiling the boundaries of parcels
4. Adding notation as needed
5. Maintenance
6. Quality control

The issues of annotation and maintenance are addressed in Section 5.8 and Section 7.0, respectively, of this document.

### **6.1 Assembling Source Data**

The first task in the creation of a parcel map is to assemble relevant records from appropriate sources. These sources include but are not limited to:

1. Title records
2. Assessment records
3. Infrastructure records (highways, utilities, transmission lines, etc.)
4. Land use and zoning regulation records
5. Resource and environmental records
6. Court records
7. Survey records (plats, plans, and surveyor notes)

<sup>5</sup> Multipurpose Land Information Systems: THE GUIDEBOOK, October, 1989, Federal Geodetic Control Committee, Chapter 13

# Interpretation of Real Property Descriptions

---

8. Aerial photographs
9. U.S. Geological Survey maps
10. Government Land Office Surveys (township plats and notes)
11. Existing parcel (or tax) maps.

Highly weighted information should be plotted first and held fixed, while lower-weighted information is fitted to it.<sup>6</sup> Highly weighted information means the most precise and accurate data available, upon which the highest degree of reliance can be placed. Weighting source data is a process by which you classify your mapping data, from the geodetic control to the parcel descriptions. It can and will determine the validity and accuracy of your maps. It should be done by a person with extensive cadastral mapping experience and a good working knowledge of surveying principles and practices. It should be noted that the various sources of control will likely be based on unrelated reference systems or bases. It is imperative that a single reference base be chosen for the entire jurisdiction being mapped and that all subsequent survey data be "rotated" to the common control base.

## 6.2 Constructing a Framework for the Parcel Maps

The framework for parcel mapping establishes a link to a ground control system that is common to all maps in a digital mapping system. This linkage has two forms: 1) direct ties by ground surveys between the National Geodetic Reference System (NGRS) and the legal referencing system for parcels and 2) the planimetric detail of the base map.

## 6.3 Compiling the Boundaries of Parcels

Once relations between locations that constitute the framework are determined, the process of placing parcels within the framework begins. This process depends upon a prioritization of the parcel records and data.

While all aspects of parcel mapping are important, particular attention should be focused on ensuring that all parcels are accounted for.

### 6.3.1 Map Boundary Compilation Issues

To effectively display and perform analysis on mapped data, consideration should be given to the following issues:

1. Tax district or taxing unit boundaries shall split contiguous ownership into separate parcels. Exceptions to this rule are subdivided lots that are already described in their smallest legal division. When a taxing district or line cuts through a subdivision lot, it shall be parcelled in the district where the largest volume of land occurs or where the improvement is located, wherever practical.<sup>7</sup>

<sup>6</sup> Multi Purpose land Information Systems: THE GUIDEBOOK, October, 1989, Federal Geodetic Control Committee, Chapter 19

# Interpretation of Real Property Descriptions

---

## **Section 7**

### **7.0 Map Maintenance**

It is important that cadastral maps be a reflection of the respective county's tax roll. A regular maintenance program should be implemented to assure that the maps are current and accurate.

### **7.1 Updating**

There should be a direct correlation between what is depicted on a parcel map and the assessment roll.

### **7.2 Quality Control**

Standard procedures for quality control should be established to continuously edit and inspect all ownership maps for accuracy, neatness, and completeness.

## **Section 8**

### **8.0 Land Descriptions**

Real property descriptions prepared for the assessment rolls shall conform to the minimum requirements as set forth in Rule 12D-8.008, F.A.C. Descriptions should be written so as to afford a taxpayer adequate notice of the tax assessed against his property. Furthermore, such clarity in a description would reduce errors in the tax sale process.

### **8.1 Interpretation**

Omission of qualifying and descriptive words and phrases should be avoided, as should unnecessary abbreviations, which would render the description nonsensical. Remainder descriptions of a parcel that has been divided should be written as negative, that is, by excepting the portion from the parent parcel for which an accurate description appears of record.

### **8.2 Abbreviation**

It is preferable, for clarity, to avoid the use of abbreviations in property descriptions except for those words or phrases that are commonly abbreviated. In such cases, usage should be made in accordance with the abbreviations and their associated meanings as given in Rule 12D-8.008, 2, (d), F.A.C.

### **8.3 Condensing Descriptions**

This is a difficult and important process and should be avoided except in extreme cases. Reducing the length of descriptions by using accepted standard abbreviations and eliminating unnecessary wording results in a more compact assessment roll, however qualifying words and phrases should never be eliminated. When bearings and dimensions are used, rounding and truncating should be avoided. If condensing a land description is

<sup>7</sup> International Association of Assessing Officers, Standards on Cadastral Maps and Parcel Identifiers, 1988, page 25

# Interpretation of Real Property Descriptions

---

necessary the corresponding public record (i.e. official record book and page) should be referenced.

## **Section 9**

### **9.0 Land Description Conflicts and Solutions**

Some of the errors, problems, and omissions encountered in land descriptions are discussed and suggested solutions offered in the sections, which follow.

#### **9.1 Double Assessment**

Double assessment is the most common error found on the assessment roll and is described as a parcel that appears on the assessment roll twice, in part or in its entirety. Parcels that are double assessed in their entirety are usually the result of errors copying, or condensing, from the source document, or failure to except a parcel from the original description.

#### **9.2 Omitted Areas**

Omitted areas are frequently the result of the excepting of an exempt parcel from a description and failing to list the descriptions for these areas. These descriptions may frequently be located in assessment rolls for prior years.

#### **9.3 Parcel in Vacated Portion of Plat**

Vacated portions of a plat have the same status as any other acreage property and should be assessed by a metes and bounds description. Plats not vacated but which are superseded by a plat recorded at a later date should be dropped from the assessment roll. The plats or parts recorded last take precedence over all earlier recorded plats of the same area.

#### **9.4 Government Lands**

The land of any governmental unit is to be mapped in the same manner as all other lands.

#### **9.5 Islands**

Islands within an assessing district are to be mapped the same as other areas of a county. The (U.S.G.S.) quadrangle maps will usually give the island name.

#### **9.6 Addressing Erroneous Descriptions**

Cadastral mapping will occasionally reveal errors in deed descriptions such as gaps, gores, overlaps and the failure to mathematically close. It is not within the scope of the duties of the property appraiser or the cadastral mapper to attempt to resolve such discrepancies. Efforts may be made to contact deed scriveners or parties in the transaction to reveal the discrepancy.

# Interpretation of Real Property Descriptions

---

## Section 10

### 10.0 Parcel Numbering

A parcel identification system provides a method for referencing land parcels, or data associated with parcels, using a number or code instead of a complete legal description. The correlation of maps and individual property records requires that all parcel files be indexed using a uniform parcel identifier.

There are three basic forms of parcel identifiers in common use: location identifiers, name-related identifiers, and alphanumeric identifiers. The primary identifier for assessment purposes should be a location identifier.

A location identifier is one in which the parcel number provides the location of the parcel. Examples include map-based identifier systems, geographic coordinate identifier systems, or identifiers related the Public Land Survey System.

Parcel identifiers should be unique and permanent, that is assigned to one and only one parcel and should change only when the boundaries of the parcel change, and a new parcel is created.<sup>8</sup>

It is recommended that, when mapping is accomplished digitally, a centroid, or geographic coordinate system of parcel identification, based upon the Florida State Plane Coordinate System be established as a secondary method of identification. Parcel identifiers using this system are composed of x and y coordinates for a single point, usually the approximate center of the parcel. The following example illustrates such a concept:

Parcel (polygon) Centroid: This number would consist of 19 numeric character fields in the current 12D-8 (NAL) file that is submitted to the Department of Revenue annually. It would be added to the end of the existing record layout and broken out as follows:

**Fields 1 through 7 would represent whole numbers left of the decimal in the State Plane Coordinate Easting (X) value;**

**Fields 8 through 14 would represent whole numbers left of the decimal in the State Plane Coordinate Northing (Y) value;**

**Fields 15 through 17 would represent condominium unit, if applicable. (Units 1-999);**

**Field 18 and 19 would denote the Datum (ie. 27= 1927 datum, 83=1983 datum).**

Since the State Plane Coordinate zone boundaries follow county boundaries and the Department requires a county code number (first 2 character fields) as part of the 12D-8 record layout, there is no need to indicate the zone nor further identify the county.

This number can be generated in two ways:

(1) Software generated; Most, if not all CADD/GIS software that are polygon based generate this number automatically when a polygon (parcel) is built. It calculates the mathematical centroid of that polygon. In many cases it is the tag (or label) point.

<sup>8</sup> International Association of Assessing offices, 1988, Standard on Cadastral Maps and Parcel Identifiers, page 10

# Interpretation of Real Property Descriptions

---

However, in some cases the mathematical center of the polygon could fall outside of the actual polygon boundary. In those cases, or if the county chooses not to use this method, the following is an alternative method:

(2) Manually generated; The mapper and/or CADD operator can physically pick the centroid point with the mouse.

As long as the actual point falls within the parcel boundary, either means is acceptable.

This number would not be a replacement to the current parcel number now in place in all 67 counties, however it would be in addition to that number and would provide an actual physical location to all parcels within the state. It is up to the discretion of the property appraiser whether this record is maintained throughout the year or only generated at the time of tax roll submission.

## **Section 11**

### **11.0 Data Archival**

It is recommended that each jurisdiction implement a plan for archival of digital map data.

In order to avoid loss of digital map data in the event of mechanical failure, a back-up copy of the map data base should be made on a regular schedule. The frequency, method, and media used for data back up will be determined by the jurisdiction's maintenance schedule.

Consideration should be given to off-site storage of the map data base to protect against the loss of on-site archived data in the event of theft, fire or natural disaster.

## **Section 12**

### **12.0 Data Exchange Standards**

Various methods of data exchange used by state, regional, local governments and private sector organizations depend on the complex matrix of hardware and software systems in place at both the source and target organizations. In determining the most desirable exchange format, considerations must be made for the preservation of accuracy and completeness, transfer efficiency, the data type (vector or raster) and the intended use of the data. In addition, compliance with F.S. 119 should also be assured.

#### **12.1 Native and Direct Data Exchange Formats**

Native data exchange formats for vector and raster data should be used for transfers between like software systems. If a direct exchange format exists between two dissimilar GIS software systems, it should be used only after a detailed investigation based on the considerations stated above in section 12.0.

# Interpretation of Real Property Descriptions

---

## 12.2 Common Data Exchange Formats

Common exchange formats listed below should be used when vector data exchange in native and direct exchange formats are not available. If compression of data is used to reduce file size be certain that the receiving agency has the appropriate software to read the data.

- **ESRI Export Format (.e00)**
- **ESRI Shape File (.shp)**
- **Spatial Data Transfer Standard (SDTS)**
- **Drawing Exchange Format (DXF)**
- **Digital Line Graphs (DLG-3) standard or optional format**
- **Initial Graphics Exchange Standard (IGES) Version 3**
- **Standard Interchange Format (SIF)**

## 12.3 Data Exchange Media

Various data exchange media are dependent on the hardware systems installed at the source and target organizations. The users exchanging data will determine the best media based on available network connections, modem connections, available input and output devices, CDROM or other transfer media.

## Section 13

### 13.0 Metadata

Metadata are commonly defined as the data about data or the data about the processes performed on data. The major uses of metadata are:

- To maintain an organization's internal investment in geospatial data.
- To provide information about an organization's data holdings to data catalogues, clearinghouses, and brokerages, and
- To provide information needed to process and interpret data to be received through a transfer from an external source.<sup>9</sup>

### 13.1 Federal Geographic Data Committee (FGDC) Metadata Standards

It is recommended that consideration be given to documentation of the data utilized in the construction of cadastral maps. The State of Florida Geographic Information Board (GIB) has chosen to adopt the full Federal Geographic Data Committee (FGDC) Content Standard for Geospatial Metadata, and reserves the right to add to this content standard as necessary to accommodate the needs of the citizens of the State of Florida. It is further recommended that the FGDC Content Standard for Geospatial Metadata be referred to as a template for documenting the quality and source of cadastral map data.

<sup>9</sup> Federal Geographic Data Committee, Cadastral Standards for the National Spatial Data Infrastructure



# Interpretation of Real Property Descriptions

## Section 14

### 14.0 Data Base Design

Particular attention should be paid to data base design and organization to facilitate data exchange among state and local governmental agencies. The following illustrates a logical model for tax parcel geometry and tabular data intended for newly designed systems, if desired.

### 14.1 Logical Model for Tax Parcel Geometry and Tabular Data

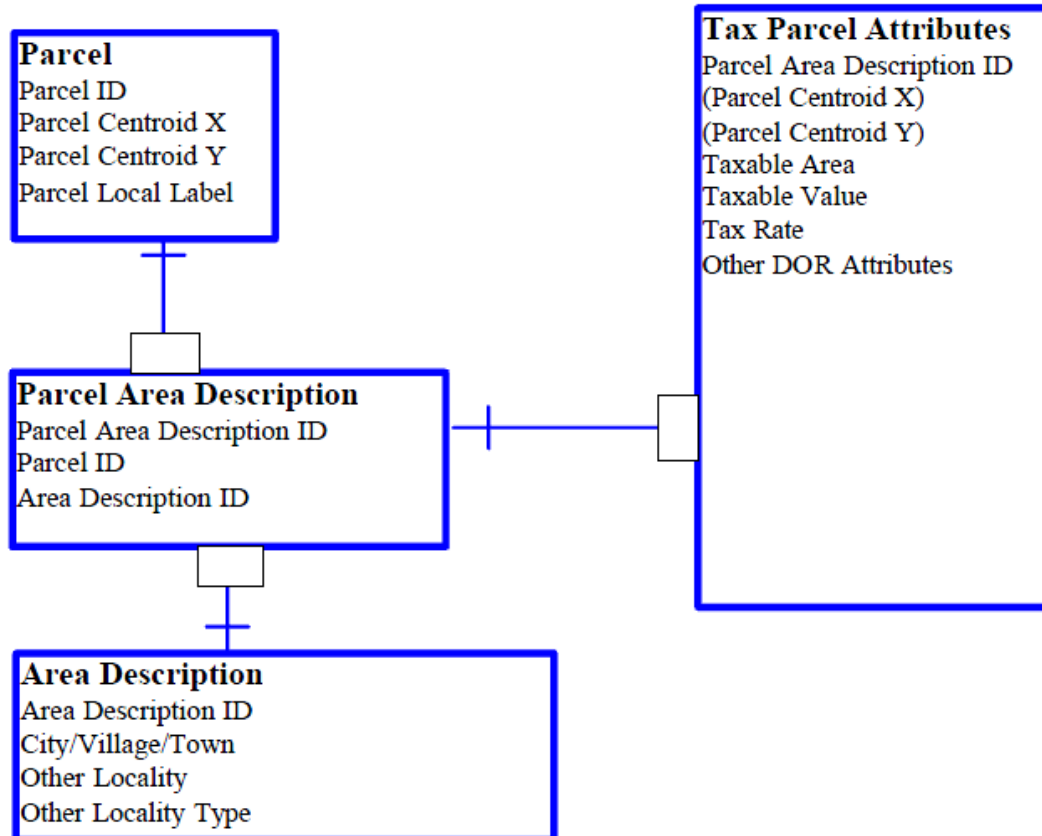

This diagram illustrates the core components for transferring the geometry of tax parcels. In this diagram, the parcel is assumed to be the tax parcel. The parcel boundaries have been determined by the local government prior to transfer. The method for computing the boundary of each parcel, such as coordinate geometry or best fit to an orthophoto, are not being transferred in this example. The parcel geometry is expressed as a Shape (or similar) file.

This model indicates that the polygons or areas that define cities, villages and towns and other tax districts may be separate shape files. For example, if the boundaries of the cities, village, and towns come from a different source than the parcels or are stored on a separate layer or as a separate object or separate graphic, then these items should be transferred as separate shape files. In these cases, the metadata for the cities, villages,

# Interpretation of Real Property Descriptions

and towns and other tax districts would be different than the metadata for the parcels.

If the city, village, and town are carried as attributes of the parcel, then any time a new city, village, or town or tax district intersects an ownership parcel, a new tax parcel is created. In this case the attributes for city, village and town and tax districts would be in the same Shape file as the parcel.

By connecting the tabular tax records to the intersecting entity, both scenarios are accomplished.

In the related tabular data file the primary key from the joining of the parcel to the tax districts is carried as the database primary key. The additional attributes for Parcel Centroid X and Parcel Centroid Y were added explicitly. In a relational database system this is not necessary, but is included to show that the linkage could also be made in this way.

## 14.2 Logical Model for Tax Parcel Boundary Geometry

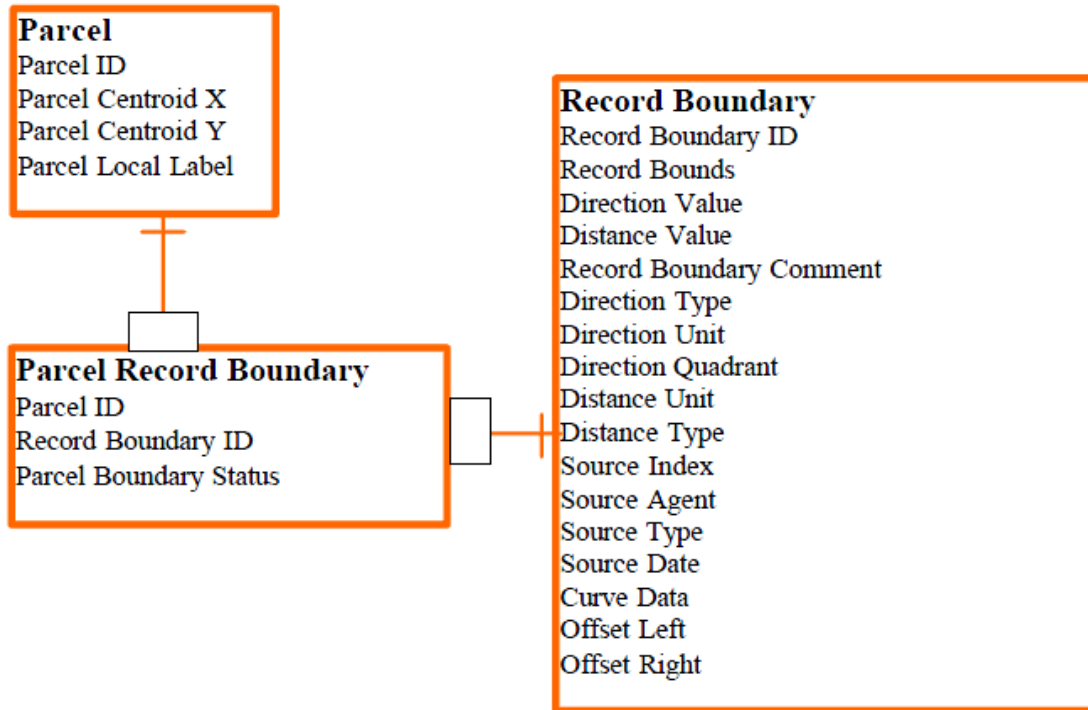

This diagram illustrates the core components for transferring the boundary information for the tax parcels from local governments to the Department of Revenue. In this diagram, as in the first diagram, the parcel is assumed to be the tax parcel. These are attributes that attach to lines in a file that describe the measurement information used to generate the tax parcel boundary.

Much of the information in this diagram is captured automatically as part of the coordinate geometry or other parcel automation process.

## 14.3 Logical Model for Tax Parcel Legal Area Description

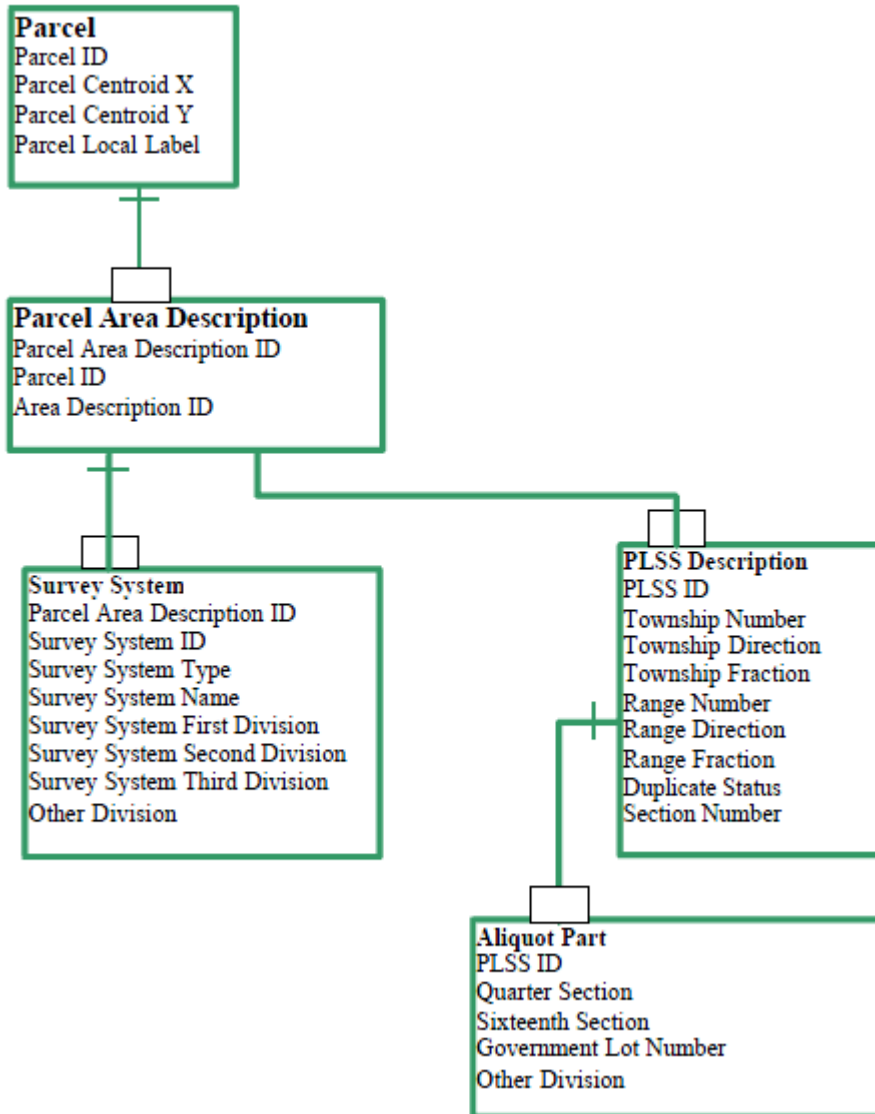

This diagram could be an attachment to a parcel geometry file from the first diagram or this may be part of the County's existing GIS or CAD data files. The content of this file serves as a checklist for the information that may need to be included in a boundary information file. The logical model provides a structure for the boundary information and standardizes the content and abbreviations. This standardization will make it easier to write programs to develop exports to or extract from a parcel boundary information file.

In terms of physical form, the information on units and source may be stored in separate look up tables that are then related to the line or boundary through the primary key, Records Boundary ID. It is also possible to further standardize the curve information and pull it out to a look up table as well.

# Interpretation of Real Property Descriptions

---

## Section 15

### 15.0 Glossary of Terms

**absolute map accuracy.** The accuracy of a map in relationship to the earth's geoid. The accuracy of locations on a map that are defined relative to the earth's geoid are considered absolute because their positions are global in nature and accurately fix a location that can be referenced to all other locations on the earth.

**base map.** A map showing certain fundamental information, used as a base upon which additional specialized data are compiled.

**cadastre .** An official register of the quantity, value, and ownership of real estate; used in determining property value.

**cadastral map.** A map showing the boundaries of subdivisions of land, for the purposes of describing and recording ownership; used in determining property value.

**compilation.** (1) Cartography: the production of a new or revised map or chart, or portion thereof, from existing maps, aerial photographs, surveys, new data, and other sources. (2) Photogrammetry: The production of a map or chart, or portion thereof, from aerial photographs and geodetic control data, by means of photogrammetric instruments.

**coordinates.** Linear or angular quantities that designate the position of a point in a given reference frame or system. Also used as a general term to designate the particular kind of reference frame or system, such as state plane coordinates or spherical coordinates.

**coordinate geometry (COGO).** Automated mapping software that translates the alphanumeric data associated with a survey (distances, bearings, coordinates, etc.) into digital map information for creating and updating a digital cartographic data base.

**centroid.** A code (usually numerical) used to locate or identify a point, such as the center of a parcel.

**Florida High Accuracy Reference Network.** The extension of the National Geodetic Reference System into Florida is referred to as the Florida High Accuracy Reference Network (HARN). A HARN is a statewide or regional upgrade in accuracy of the North American Datum 1983 (NAD83) coordinates using GPS observations.

**geodesy.** A branch of applied mathematics concerned with the determination of the size and shape of the earth and the exact positions of points on its surface and with the description of variations of its gravity field.

**geodetic coordinates.** The quantities of geodetic latitude or longitude that define the position of a point on the surface of the earth with respect to the reference spheroid.

# Interpretation of Real Property Descriptions

---

**geographic coordinates.** A system of spherical coordinates for defining the position of points on the earth. The declinations and polar bearings in this system are the geographic latitudes and longitudes respectively.

**Geographic Information System (GIS).** A computerized data-base system for capture, storage, retrieval, analysis, and display of spatial data.

**geoid.** The shape of the earth as a three-dimensional spheroid that coincides with the surface of the earth at sea level and extends in an imaginary surface through the continents with a direction of gravity that is perpendicular at every point.

**geometric.** Of, relating to, or according to the methods or principles of geometry.

**Global Positioning System (GPS).** Determination of coordinates of points using a network of satellites intended for this purpose.

**index map.** (1) A map of smaller scale on which are depicted the locations (with accompanying designations) of specific data, such as larger-scale topographic quadrangles or geodetic control. (2) Photography: A map showing the location and numbers of flight strips and photographs.

**lot.** A plot of land, generally a subdivision of a city, town, or village block, or some other distinct tract, represented and identified by a recorded plat.

**monument.** A permanent physical structure marking the location of a survey point or boundary line. Common types of monuments are inscribed metal tablets set in concrete post, solid rocks, or parts of buildings: distinctive stone posts; and metal rods driven in the ground.

**multipurpose cadastre .** A framework that supports continuous, readily available, and comprehensive land-related information at the parcel level.

**parcel.** A single, discrete piece of land having defined physical boundaries and capable of being separately conveyed.

**photogrammetry.** The art, science, and technology of obtaining reliable information about physical objects and the environment through processes of recording, measuring, and interpreting images and patterns of electromagnetic radiant energy and other phenomena.

**planimetric map.** A map that presents only the horizontal positions for the features represented; distinguishable from a topographic map by the omission of relief in measurable form.

## Interpretation of Real Property Descriptions

---

**plat.** A diagram drawn to scale showing all essential data pertaining to the boundaries and subdivision of a tract of land, as determined by survey or protraction.

**projection.** A systematic representation of all or part of the surface of a sphere onto a plane.

**relative map accuracy.** The accuracy of a map in relation to a local survey network that is not tied to the earth's geoid. The accuracy of locations on a map defined relative to a local survey network is considered relative because the positions are accurate only within a certain geographic area covered by the network.

**state plane coordinate systems .** A series of grid coordinate systems prepared by the U.S. Coast and Geodetic Survey for the entire United States, with a separate system for each state. Each state system consists of one or more zones. The grid coordinates for each zone are based on, an mathematically adjusted to, a map projection.

# Interpretation of Real Property Descriptions

## Appendix A

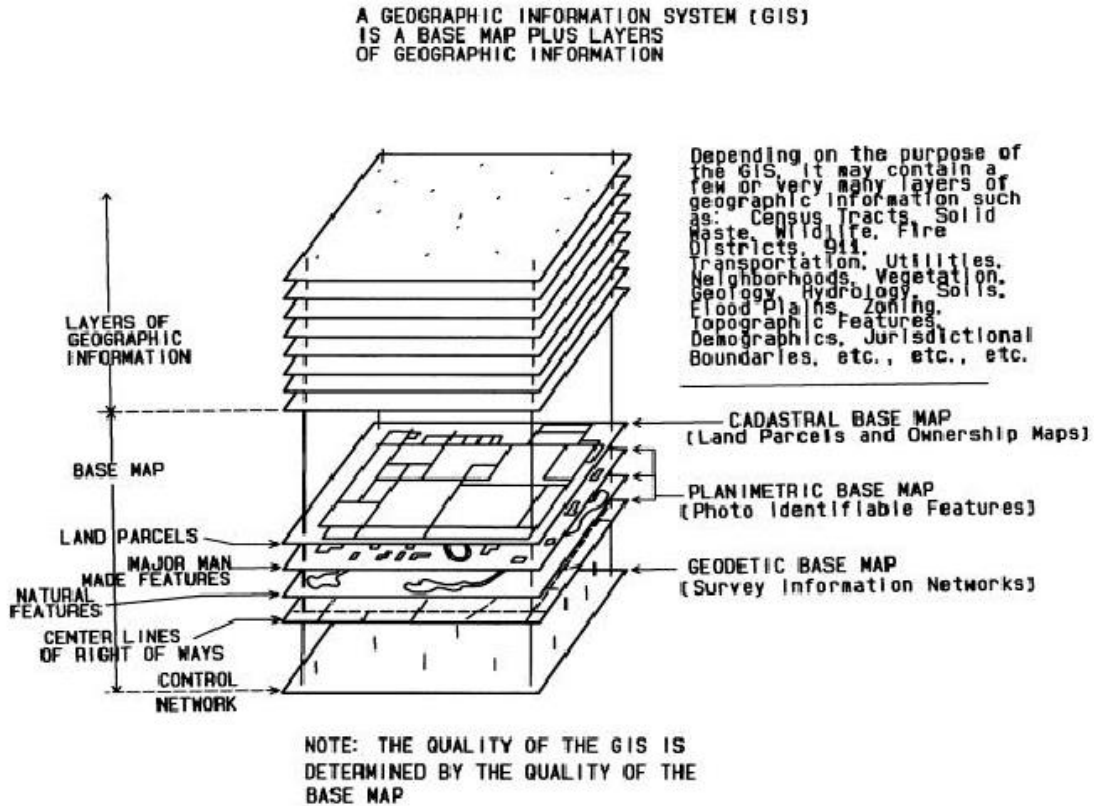

## Appendix B

### United States National Map Accuracy Standards

With a view to the utmost economy and expedition in producing maps which fulfill not only the broad needs for standard or principal maps, but also the reasonable particular needs of individual agencies, standards of accuracy for published maps are defined as follows:

**1. Horizontal Accuracy.** For maps on publication scales larger than 1:20,000, not more than 10 percent of the points tested shall be in error by more than 1/30 inch, measured on the publication scale; for maps on publication scales of 1:20,000 or smaller, 1/50 inch. These limits of accuracy shall apply in all cases to positions of well-defined points only. Welldefined points are those that are easily visible or recoverable on the ground, such as the following: monuments or markers, such as bench marks, property boundary monuments; intersections of roads, railroads, etc.; corners of large buildings or structures (or center points of small building); etc. In general what is well defined will also be determined by

## Interpretation of Real Property Descriptions

---

what is plottable on the scale of the map within 1/100 inch. Thus while the intersection of two road or property lines meeting at right angles would come within a sensible interpretation, identification of the intersection of such lines meeting at an acute angle would obviously not be practicable within 1/100 inch. Similarly, features not identifiable upon the ground within close limits are not to be considered as test points within the limits quoted, even though their positions may be scaled closely upon the map. In this class would come timber lines, soil boundaries, etc.

**2. Vertical accuracy**, as applied to contour maps on all publication scales, shall be such that not more than 10 percent of the elevations tested shall be in error more than one-half of the contour interval. In checking elevations taken from the map, the apparent vertical error may be decreased by assuming a horizontal displacement within the permissible horizontal error for a map of that scale.

**3. The accuracy of any map may be tested** by comparing the position of points whose locations or elevations are shown upon it with corresponding positions as determined by surveys of higher accuracy. Tests shall be made by the producing agency, which shall also determine which of its maps are to be tested, and the extent of such testing.

**4. Published maps meeting these accuracy requirements** shall note this fact on their legends as follows; "This map complies with National Map Accuracy Standards."

**5. Published maps whose errors exceed those forestated** shall omit from their legends all mention of standard accuracy.

**6. When a published map is a considerable enlargement** of a drawing (manuscript) or of a published map, that fact shall be stated in the legend. For example, "This map is an enlargement of a 1:20,000-scale map drawing," or "This map is an enlargement of a 1:24,000-scale published map."

**7. To facilitate ready interchange and use of basic information for map construction** among all Federal mapmaking agencies, manuscript maps and published maps, wherever economically feasible and consistent with the uses to which the map is to be put, shall conform to latitude and longitude boundaries, being 15 minutes of latitude and longitude, or 7.5 minutes, or 3-3/4 minutes in size.

### U.S. BUREAU OF THE BUDGET

Issued June 10, 1941  
Revised April 26, 1943  
Revised June 17, 1947



## Appendix C

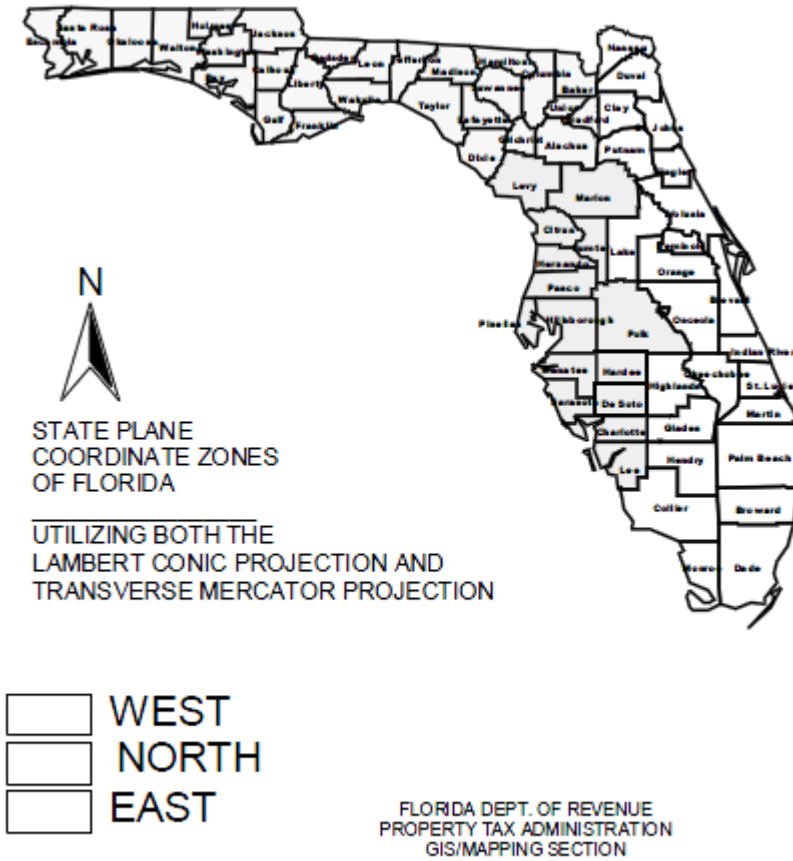

# Interpretation of Real Property Descriptions

---

## Property Appraiser Mapping - Quiz

1. The Mapping Requirements under 12D-1.009 of the F.A.C. state that property ownership maps should show the dimensions and acreage, where known, on all parcels over \_\_\_\_\_ in size.
2. Under 12D-8.008(2)(e) of the F. A. C. every parcel number should be \_\_\_\_\_.
3. What is the reasoning behind the abbreviations to be used in legal descriptions listed under 12D-8.008(2)(d) of the F.A.C.?  
\_\_\_\_\_
4. What is the abbreviation to be used for the word “fractional“?  
\_\_\_\_\_
5. Which Florida Statute covers listing all property on the tax roll?  
\_\_\_\_\_
6. The title block on a cadastral map may include the following: Acreage, parcel number, parcel dimensions. TRUE FALSE
7. What five cartographic elements should appear on all cadastral maps in order to facilitate functionality?  
\_\_\_\_\_  
\_\_\_\_\_
8. List five different types of lines that may be shown on a cadastral map.  
\_\_\_\_\_

# Interpretation of Real Property Descriptions

---

This page intentionally left blank

# Day 4

## Resolving Problems, Mapping Exercise (1/4 Section)

## **RESOLVING PROBLEMS**

This chapter attempts to provide some guidelines which you may use in resolving conflicts among the calls of a description or between two or more descriptions. This is always the hardest part of interpreting descriptions. Just as different humans have different abilities and skill levels, so do the authors of descriptions. Over the years the courts have drawn upon the law of England, the common law of the United States, statutory law and created our own case law. In Florida almost all the rules we use in resolving conflicts in descriptions come from case law. The actual statutes themselves contain very little information on the subject. We shall use this case law to set some basic “rules”.

The interpretation of descriptions gets to the heart of surveying and mapping after the technical work is complete - the law portion. This presentation will not make you an expert on surveying/boundary law but should help you to understand how to interpret descriptions.

### **Different Feet, Degrees, Curves and Elevations**

Yes, there are different:

#### **Feet -**

There are two different definitions of a foot - the definition used by North America is solely used in surveying and is normally referred to as the “Survey Foot” or the “North American Survey Foot.” The other definition is called the “International Foot.” Over the years mankind has attempted to define his various units of measure. I’m sure we all remember being told in grade school about the yard being the distance from a certain King of England’s nose to the tip of his outside stretched forefinger and the foot being the length of his foot. Well, we’ve come a little ways down the road from that, but still we define the foot as a relationship to a natural object. The latest being a single wave length of a certain colored light from a laser created from a certain gas. The length is called the meter. The length of an “International” foot is defined as “0.3048 meters exactly.” The definition a “survey” foot is 1200/3937 of a meter or 0.304800609601 of a meter. So if you see either, you will know that they mean.

#### **Degrees -**

There are two of them as well. Normal degrees like one sees in most descriptions are called “Sexagesimal.” They contain 360 degrees with 60 minutes per degree and sixty seconds per minute and came to us originally from the Babylonians. The other is called “Grads” and is used extensively in Europe, Canada and most other countries. It’s the metric angle measurement method. There are 100 degrees in a right triangle, 100 minutes in a degree and 100 seconds in a minute.

## Interpretation of Real Property Descriptions

---

### **Curves -**

Yes, there are two types of curves as well. Before we had computers people looked for ways to simplify the determination of the elements of curves. While normally if one has any two parts of a curve the rest can be determined, it is not true in all cases. However, if one has the radius and the central angle, all the remaining elements of a curve can be determined.

With the railroads becoming increasingly important in the 1800's the use of curves became much more necessary. The railroad's defined their curve's radii as a relationship between the length of a long chord to the degree of change in direction. That definition says a one degree curve has the long chord length of one hundred feet. It is commonly termed the "Railroad Definition Curve." The radius of a one degree railroad curve is 5729.6507 feet.

However, the highway builders of the early and mid-1900's said that they wanted to retain the traditional methods because they had a good relationship between the arc length and the amount of change in direction of a curve. It is called the "Highway Definition Curve" and is what almost everyone uses today. It is based on the radius of a one degree change in direction equals an arc length of one hundred feet. The radius of a one degree highway curve is 5729.5780 feet. While most curves found in today's deeds, plats, etc., are all simple (highway) curves, some of the older state road right of way maps are based on railroad curves particularly if the highway is following the right of way of an old railroad. Some of the older deeds are based on the railroad definition as well. So if you can't get a curve to work by using the highway definition, try the railroad definition.

### **Elevations -**

There are at least two different elevation sets as well. The first and still more common is called the National Geodetic Vertical Datum, Adjustment of 1929 commonly referred to as NGVD. The other is called the North American Vertical Datum (NAVD). Since very, very few descriptions use elevations, there will not be any further discussion on them although they are used extensively in condominium graphic descriptions.

# Interpretation of Real Property Descriptions

---

## Relationship between Descriptions and Surveys

A large portion of the law concerning what to hold, what to reduce in importance and what are the meanings of the words used in descriptions comes from the presumption by the courts that the description was prepared from a survey. The courts are just trying to follow what they think the surveyor and mapper did, taking into consideration the limits of accuracy of the equipment and which equipment was better than the other at doing its job. Understanding how surveyor and mappers work or at least what situations may exist in the “real world”, will allow a layperson to more fully understand and interpret descriptions. It will also be helpful to understand the problems surveyor and mappers had/have with their equipment.

### **All Measurements Have Some Error -**

One must understand that no measurement is exact or the true measurement, either in the distance or the angle. They are simply estimations of the true measurement. Surveyor and mappers have known this since the beginning of history, but it seems a difficult fact for the layperson to understand.

To help everyone understand, remember the installation of the final piece of the Gateway Arch in Saint Louis? The surveyors waited until the sun’s rays had sufficiently heated the metal of the existing arch so that the final piece would fit into place without a problem. Ever see the cuts that are made in concrete to take care of the expansion and contraction of the concrete? Well the same thing happens in measurements.

The metal chain or tape is longer in the summer than they are in the winter because metal expands with increasing temperature. The temperature of a metal tape lying on an asphalt roadway is over 140 degrees Fahrenheit. This causes the tape to actually lengthen by about 0.04 hundredths, thus making the measurements taken shorter than what they actually are. That’s why if surveyor’s are using a metal tape for measurement they need to do temperature corrections based on the temperature at the time they are measuring.

When looking through the telescope of the angular measurement instrument at an object on the surface, one sees that object appear “jump around” and “phase shift”. Your eyes begin to “jump around” too, attempting to follow the object sighted through the instrument. Did you ever see the heat waves coming off snow during a filming on Mount Everest at a height of 25,000 feet? Ever see the stars twinkle? All that jumping/shifting around affects the accuracy of any measurement made through the air.

## Interpretation of Real Property Descriptions

---

Surveyor and mappers came up with a rough means to estimate the validity of their measurements called an error of closure. In basic terms, in a closed traverse (where a survey starts and ends at the same point), a mathematic ratio can be determined by using the distance and angle between the known starting point and the actual closing point. While doing a survey in the field, the final sighting is always made to the closing point, but, mathematically, there is no way to be that exact.

The standard acceptable error of closure in the early 1800's when the state was first extensively measured by the federal government was one foot of error in each 400 feet of measured line (commonly expressed as 1:400) and for the time that was pretty good. But not as good as the ancient Egyptians who's Great Pyramid of Giza's base was measured or set out at an error ratio of 1 foot error in every 1500 feet. Common everyday surveys didn't get much better till the late 1800's. While the earlier official instructions did not contain an acceptable error ratio figure, the computations on some of the original surveys in Florida reflect that error closure ratios as low as 1:200 were accepted by the Surveyor General. Later that ratio became 1:1000. Little changed until the 1940's and 1950's when the minimum acceptable ratio became 1:5000, a one thousand percent increase in accuracy or roughly ten percent per year. Today the state of Florida has stated the following ratios based on the states' estimate of perceived land values:

Rural.....: 1 foot in 5,000 feet;

Suburban...: 1 foot in 7,500 feet;

Urban.....: 1 foot in 10,000 feet.

These ratios are easily met by today's methods and instruments. The [American Land Title Association/American Congress on Surveying and Mapping](#) (ALTA/ACSM) has stricter requirements which are also easily met.

### **Accuracy of Measurement Equipment -**

At first (early 1800's) the distance measuring equipment was the more accurate. That's why the courts in this county (and in England) have stated that the distance will hold over the angle. Later, around the change in the century to the twentieth, the angles actually got better than the chain with the introduction of the transit to everyday surveying. Shortly thereafter the steel ribbon tape came into common use and the distance equipment seemed to equal the angles.

Just after the mid part of the Twentieth Century the theodolite came into fairly common use in the United States and the angles got better than the distance measuring equipment. In the early 1970's the first affordable, electronic distance measurement equipment appeared. Since



# Interpretation of Real Property Descriptions

---

then little has changed other than electronic angle measuring equipment removing most of the instrument's internal error producing problems. With the advent of the electronic field books of today, there is a greatly reduced chance for human error. Now the angle and distance measuring equipment are about equal in accuracy given good operators.

## Legal Aspects of Descriptions

Now that the technical level has been explained, let's discuss the legal aspects of interpreting descriptions.

We need to determine what legal jurisdiction the lands are in: federal or state.

### **Federal -**

If the land is still in federal ownership, different controls than in private or state hands may be applicable. Since the federal government has little, if any, land still available for purchase in Florida, this should not be too much of a worry.

### **State -**

The same thing can be said for state ownership, but in the real world, it's not a concern, except in those areas where the state was the original surveyor.

### **What Makes A Description Valid? -**

Since the courts assume that each description was created from a survey, they assume that if a surveyor, even with extrinsic evidence, can place the description back on the ground then the description is valid. So if a surveyor can survey it, it is valid.

### **Following in the Foot Steps of the Original Surveyor -**

The method most accepted to determine the true position of a described parcel is to follow in the footsteps of the author, which we assume is a surveyor and mapper. Again, this presumes that the description was written from a survey when in today's world; most descriptions are written then placed on the ground. What did the author intend?

### **What Controls?**

Junior/Senior Rights, Intention of the Parties, and other similar items are matters for the law and Surveyor and Mappers. This section is to help explain some of the informal rules that may be used to help one follow in the footsteps of the surveyor and mapper and interpret the written description in a deed as a stand-alone document.

# Interpretation of Real Property Descriptions

---

## **Rules of Superiority Based on Equipment & Logic -**

The discussion above relating to equipment will, in general, assist one in understanding why the courts have determined what one should first hold over another. Unfortunately, the courts do not move as fast as technology and are grossly out of date with the real world. That is one of the problems with basing one's decision on what someone else, who, in apparent similar conditions, said to do.

## **Superiority of Calls**

### **(1) *Lines As Actually Run In The Field (Following In The Footsteps of The Surveyor and Mapper)* -**

Obviously, the location of the line as actually run in the field is the one true line of the lands to be included within the description. Short of running out each parcel in the field, one makes assumptions about the location of the description based on the words in the description and the full document itself. The courts have, informally, determined that certain things are "better" about controlling description location than others. They are discussed below.

### **(2) *Natural "Monuments"* -**

The courts assume that natural objects should control over most any other call in the description. A call which says "...to the Gulf of Mexico..." doesn't, on the surface, leave much doubt as to the object to which one goes. The problem that arises in such a call is what part of the Gulf of Mexico? The top of the bank, the shore line, the mean high water line, where the water was on the day and time the surveyor and mapper was there?

### **(3) *Record "Monuments"* -**

Next in line are the called for public recorded objects. A call to the right of way of a road is a call to a record monument. A call to a road similar to: "...along the Tamiami Trail..." is still a call to a record monument. It just doesn't say to what part of the record monument.

### **(4) *Original Artificial "Monuments" Called for in the Description* -**

The word artificial is talking about a manmade monument such as a concrete marker. So calls to an artificial object, such as a 4"x 4" concrete marker, will control next. This is under the theory that the surveyor has told the reader what was set or found during the survey in the description so one is following in the footsteps of the surveyor.

## Interpretation of Real Property Descriptions

---

(5) ***Manmade Artificial "Monuments" Not Called for in the Description*** -

If no object was called for in the description, but a review of the survey drawing from which the description was prepared reflects artificial monuments, then they will be the next in line. Again, this is done to follow in the footsteps of the surveyor and mapper. Sometimes, even manmade artificial monuments that must have existed at the time of survey as disclosed by reference to maps and or other documents of record will control at this point.

(6) ***Distances*** -

When this hierarchy was first set up, the compass was the prevalent angle measurement device. It just wasn't very accurate and it was common knowledge that the Gunter's chain was a better measurement device. Therefore, the courts said that one should use the distance called for in the description.

(7) ***Bearings or Angles*** -

Next in this list is the compass bearing of the line.

(8) ***Area*** -

The final formal item that one may use in the determination of the original surveyor and mapper's footsteps is the area if stated in the description. The courts have said that since area is the result of computations of the measured courses and distances and not a direct measurement, that it should be used last in determining the footsteps of the surveyor and mapper.

Of course all of this is subjective and **any part or all can be overcome by better evidence**, but it will give one a systematic means to assist in ascertaining the footsteps of the original surveyor. Remember, the presumption is that the description was prepared from an original survey made on the ground prior to the description being prepared and the object is to follow in that surveyor and mapper's footsteps even if the intent of the seller was a different parcel.

## PRACTICAL ASSISTANCE

### **...ly Parts of a Parcel** -

Many descriptions call for the ...ly portion of a parcel. So many in fact that the ...ly direction has been stretched to the limit, particularly by the layperson.

Just remember that in the absence of the evidence to the contrary, if someone has used the terminology of "Sly, Nly, Ely, Wly, etc." that the distance is to be measured at right angles to the line called the ...ly. If the Southerly fifty feet of a parcel is

## Interpretation of Real Property Descriptions

---

described and the South line is easily determined, the distance of fifty feet is measured from that South line at a right angle.

### **Direction of Line Segments vs. Whole Line -**

If a call in a description says something like “...along the Easterly Line thereof...” and the overall line is actually many different segments, some of which do not run generally North and South, what happens? According to Wattles, the courts have generally held that a group of consecutive lines, even though they may have different directions, some of which may be in a different direction from the majority, can still be considered along a general direction. Review the definition of “along” and “with” back in Day 1.

### **Each or Either -**

These words are commonly used in strip descriptions to describe the fact that the entire strip of land involved in the description is on both sides of the described line. While the word “either” means, in general usage, only one of the sides one must read the entire description to ascertain the meaning of the author. If the author used the word “centerline” in the description or has different specifically mentioned widths for each side, then the word “either”, as used in that description, would seem to mean both sides rather than a single side.

### **Curves (Just A Portion of a Circle - An Arc) -**

Remember the different curve definitions? Refer to Day 2.

#### Application of Rehabilitation Methods -

Or in other words, when a curve doesn't work correctly, how to figure out what is wrong and correct it. When faced with a curve that doesn't seem to work correctly or some parts of its provided data don't mesh with the remaining parts, use a computer program that computes the elements of curves quickly and accurately. Then one can find what parts of the given information mesh with each other.

The computed elements are sometimes called the sub elements. Because all other elements of a curve can be computed from the radius and the delta, most mappers assume that they are the primary elements unless otherwise indicated by the values of the other elements. So check a curve first using those two elements, computing the remaining elements and comparing them to the provided information. Only then, or unless otherwise indicated by the sizes of the other elements, will you be able to analyze the other elements as being a primary element.

# Interpretation of Real Property Descriptions

---

## Figure Out How The Curve Was Created In The First Place -

Look at the information provided to you by the description author. If you only have three of the elements of a curve to work with, you are pretty much limited to the review of those three elements to see how you would create the curve yourself. The most common three parts are the radius, the delta or central angle and the arc length; the first two of which are the most common primary elements. But look again; did the curve start and stop on tangent lines where you are provided with the bearing of each? Then you now have a check of the delta angle.

Look at the delta or central angle. Would the size of it be determined prior to the remaining portions of the curve? Are the bearings coming into the curve fairly common through out the description or sounding area? Was the delta determined by field measurement prior to the curve being computed (typical with highway curves)? Is the number an even degree or minute? Then the chances are that it is a primary element and was used to compute the remaining elements.

## Keep it Simple -

Most people like to keep things simple. One of the ways to do that is to pick an element or several elements of the curve even or “flat” numbers. This tends to make things simpler and easier to compute if one only has to multiply something times an even foot radius. Speed and accuracy was greatly increased. Take 0.99874523 times 403.456. Now take that same 0.99874523 times 400. Which is easier to do? We just multiplied a radius times a central angle measured in radians to determine an arc length.

## Degree of Curve -

The most common highway curves will have their radius determined by the degree of curve as determined by the engineers for the design speed of the highway curve. That’s how they determine the radius of the curve; they set the design speed they want for the roadway and that dictated the degree of curve -which gives us what we want which is the radius of the curve. They tend to pick an even number such as  $01^{\circ}$  or  $00^{\circ}30'$  or  $06^{\circ}$ . With the degree of curve and the delta, one can compute the rest of the elements of the curve and check the provided data. Look also for the tangent to be of even length or the arc or the chord. These are almost sure signs that the author picked those elements to begin the computations. The two elements that the author used to compute the rest of the elements are, what I call, the primary elements.

# Interpretation of Real Property Descriptions

---

## Interpretation of Simple Curves -

On highway curves, subtract the stationing to determine the station to station arc length and the tangent length. Do they match the data when computing from the primary elements? In any case you now have a check of the arc length and the tangent length. If they match the other information - great! If they don't, maybe the author computed something wrong or it wasn't correctly proofread after typing. At least you now know that something is wrong and you can treat that curve with suspicion.

## Curve Format In A Description -

People tend to provide the elements of curves differently in descriptions so it helps to read the entire description before you start to plot the description. A few of the keys to figuring out a curve is to pick all the elements of a curve you can from the description and keep multiple curves separate from each other. You might want to draw a red line after all the elements of a curve are described in order to separate it from the next curve in the description.

The following are several examples of how different people write curves within a description.

“...thence S.89°E. a distance of 10.00 feet to the Point of Curvature (PC) of a curve to the right, having a central angle of 10°12'45" and a radius of 400.00 feet; thence, Easterly, along the arc of said curve a distance of 71.30 feet the Point of Tangency (PT); thence S.78°47'15"E. a distance of ....”

“...thence S.89°E. a distance of 10.00 feet to the Point of Curvature (PC) of a curve concave to the South; said curve having as its elements a radius of 400.00 feet, a central angle of 10°12'45" and an arc length of 71.30 feet; thence along said curve to the Point of Tangency (PT); thence S.78°47'15"E. a distance of ....”

What information comes first in a definition of a curve doesn't define the primary elements. Two things controlled how that curve was computed. One of the primary elements typically will be the radius length. As to the other, insufficient information is given to determine that, but a computation that didn't agree with that radius length would be suspect.

## **Consistent Curve Writing Methods -**

Competent surveyor and mappers will, in general, determine the direction a description is written based on the various items that will be included within that description and how that surveyor wants them controlled. Some people will always

## Interpretation of Real Property Descriptions

---

write their descriptions clockwise beginning near the Southwest Corner. Some will always write them clockwise starting near their initial corner or Point of Commencement. Just about all will change their standard practice to avoid a non-tangent intersection. Once you get familiar with how a person writes their descriptions you can normally recognize their descriptions even if the attorney didn't record the description sketch along with the description. This is most helpful because you get to know a person's weaknesses and their strengths. If you spot a deviation from their normal method, you should look for the reason why and act accordingly.

### **Non-Tangent Arcs** -

The chord and chord bearing are not primary elements of a curve, they are sub-elements and, most importantly, they are almost always computed from the primary elements. Seldom is either the long chord or long chord bearing used to compute any of the other elements. You should always draw the curves the same way that they were created, by using the primary elements. Normally the radius length and the delta angle are the primary elements. The degree of curve and the delta are the primary elements on most highway curves.

## INTENT

Intent is a term used to describe the probable intentions of the grantor and grantee as determined from the document itself. As we have discussed, surveyor and mappers, lawyers, and occasionally non-specialists write descriptions. A single error, such as an improper numerical value or a misplaced word or punctuation mark, may result in litigation. That could throw the entire neighborhood's land titles and perimeters in question and cause great harm for several years if the intentions of the grantor and grantee are not fulfilled. Every attempt should be made to interpret what was the actual intent.

## SENIOR RIGHTS

One of the most important logical means to determine what lands belong to a deed is senior rights. While they can be overcome, it takes a lot of additional evidence to do so. Simply put, senior rights are nothing more than one can't sell something twice. Once sold, the original owner no longer has control of the land. Just remember that, and when the next document is passed into your hands that includes something that was already sold by the same seller, you will know that to do. You should bring the problem to either your supervisor or notify the person who prepared that document.

## WHEN ALL ELSE FAILS

While the hints provided in this course will greatly assist you in “interpreting descriptions”, they of course cannot equal the knowledge of a description by its author. Therefore, in case of a question or conflict, seek the words of wisdom from the author. If all you have is a recorded document, call the person that Florida law requires to be on the document - that person who prepared it. While that may not get you direct to the author, it will put you on the road to the author. **DO NOT BE BASHFUL WHEN SEEKING HELP!** Most people will want to give it. Above all, be kind, courteous and respectful. You should request assistance in a manner that will make the person want to help you.

Maybe the description was prepared from a survey. Ask for a copy of that survey. Quite often just by reviewing the survey you will be able to figure out the error in the description on your document.

### **5J-17.052 Standards of Practice – Boundary Survey Requirements.**

#### (5) Descriptions/Sketch to Accompany Description:

- (a) Descriptions written by a surveyor and mapper to describe land boundaries by metes and bounds shall provide definitive identification of boundary lines.
- (b) When a sketch accompanies the property description, it shall show all information referenced in the description and shall state that such sketch is not a survey. The initial point in the description shall be tied to either a government corner, a recorded corner, or some other well-established survey point.



# Interpretation of Real Property Descriptions

---

## Resolving Problems Quiz

1. The distance of 0.3048 meters exactly is the length of an \_\_\_\_\_ foot.
2. The degrees used in most North American descriptions are called \_\_\_\_\_.
3. The type of curve that says a one degree curve has the long chord length of 100 feet is termed the \_\_\_\_\_ curve.
4. What is the acceptable ratio of error in the state of Florida for urban areas?  
\_\_\_\_\_
5. On a hot summer day a metal tape measurement will cause the metal to \_\_\_\_\_ and therefore the measurement will actually be \_\_\_\_\_.
6. A call to the boundary of a parcel as described in OR Book 5682 Page 1256 would take precedence to a call to the shoreline of the Gulf of Mexico.  
TRUE            FALSE
7. A call to 4" x 4" concrete monument takes precedence over the distance of 200 feet called for in the deed.  
TRUE            FALSE
8. A description which calls for the "Northerly 50 feet of Lot 10" should measure the 50 feet from the \_\_\_\_\_ boundary of the lot.
9. Which are the most common two elements of a curve from which all other elements of the curve are calculated?  
\_\_\_\_\_
10. What is the term used to describe the probable intentions of the grantor and grantee as determined from the document itself.  
\_\_\_\_\_
11. The term that means that one cannot sell something twice is called \_\_\_\_\_.
12. If you are having a problem with a description that simply does not "work" who should you call?  
\_\_\_\_\_

# **DAY FOUR MAPPING EXERCISES**

**NW1/4 OF  
SECTION 14  
TOWNSHIP 29 SOUTH  
RANGE 24 EAST**

**Draw the legal descriptions on the  
deeds in the following pages  
on the map provided.**

**Be aware that some bearings and  
measurements in the following deeds may  
contain errors to make you determine the  
superiority of calls or reliance on other  
information provided.**

# Interpretation of Real Property Descriptions

This Instrument Prepared By:  
Name: Joe Jackson, Attorney at Law  
Address: 4233 Pool Branch Rd  
Homeland, FL 33801

## WARRANTY DEED

Made this 11<sup>th</sup> day of November, 2007 A.D. by **Jeremiah Longoria and Cheryl Longoria, husband and wife**, whose post office address is: 429 Deer Creek Avenue, Auburndale, FL 33823 hereinafter called the Grantor, to **Herman F. Bellman and Mary A. Bellman, husband and wife**, whose post office address is: 881 Fairway Avenue, Lakeland, FL 33801, hereinafter called the Grantee:

(Whenever used herein the term "grantor" and "grantee" include all the parties to this instrument and the heirs, legal representatives and assigns of individuals, and the successors and assigns of corporations)

**Witnesseth**, that the grantor, for and in consideration of the sum of Ten Dollars, (\$10.00) and other valuable considerations, receipt whereof is hereby acknowledged, hereby grants, bargains, sells, aliens, remises, releases, conveys and confirms unto the grantee, all that certain land situate in Polk County, Florida, viz:

Commence at the Southwest corner of the SE1/4 of the NW1/4 of Section 14, Township 29 South, Range 24 East, run thence N 89 deg 46' 35" E 30 feet to the East boundary of Ball Park Road, thence N 00 deg 37' 00"W along the East boundary of said road 475 feet for Point of Beginning; continue N 00 deg 37' 00"W 512.28 feet to a point on the Southwest corner of Highland Terrace Subdivision as recorded in Plat Book 74 page 42 of the Public Records of Polk County, Florida, thence N 69 deg 51' 22"E along the South boundary of said subdivision 1635.48 feet to SE corner of said subdivision, thence N 00 deg 36' 58"W 339.47 feet to the Northeast corner of said subdivision and to a point on the North boundary of SE1/4 of the NW1/4 of section, thence N89 deg 52' 42"E 300 feet, thence parallel to the East boundary of SE1/4 of NW1/4 of said Section 14 S 10 deg 36' 53"E 850.44 feet, thence S89 deg 46' 33"W 935.43 feet to Point of Beginning. Parcel ID# 142924-000000-032040

Together with all the tenements, hereditaments and appurtenances thereto belonging or in anywise appertaining.

To Have and to Hold, the same in fee simple forever.

And the grantor hereby covenants with said grantee that the grantor is lawfully seized of said land in fee simple; that the grantor has good right and lawful authority to sell and convey said land, that the grantor hereby fully warrants the title to said land and will defend the same against the lawful claims of all persons whomsoever, and that said land is free of all encumbrances except taxes accruing subsequent to December 31, 2006.

In Witness Whereof, the said grantor has signed and sealed these presents the day and year first above written.

Signed, sealed and delivered in the presence of:

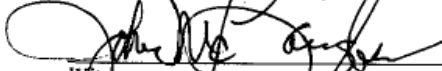
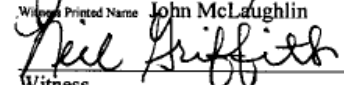
  
Witness  
Witness Printed Name John McLaughlin  
  
Witness  
Witness Printed Name Neil Griffith

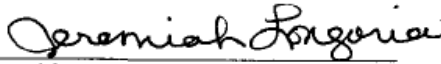
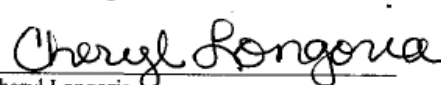
  
Jeremiah Longoria  
  
Cheryl Longoria

STATE OF FLORIDA  
COUNTY OF POLK

The foregoing instrument was acknowledged before me this 11<sup>th</sup> day of November 2007 by Jeremiah Longoria  
+ Cheryl Longoria, who is personally known to me or has produced his/her driver's license as identification.

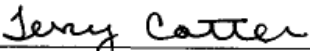

  
Signature - Notary Public  
Print Name: Terry Cotter

My Commission Expires: 12-1-2009

# Interpretation of Real Property Descriptions

This Instrument Prepared By:  
Name: Titan Land Title  
Address: 2154 Broadway  
Tampa, FL 33619

## WARRANTY DEED

Made this 20<sup>th</sup> day of June, 2006 A.D. by **William Manning and Susanne Manning, a married couple**, whose post office address is: 9503 Parker Road, San Antonio, TX 78217 hereinafter called the Grantor, to **Kent Lightsey and Madison Lightsey, husband and wife**, whose post office address is: 1959 Citrus Drive, Bartow, FL 33830, hereinafter called the Grantee:

(Whenever used herein the term "grantor" and "grantee" include all the parties to this instrument and the heirs, legal representatives and assigns of individuals, and the successors and assigns of corporations)

**Witnesseth**, that the grantor, for and in consideration of the sum of Ten Dollars, (\$10.00) and other valuable considerations, receipt whereof is hereby acknowledged, hereby grants, bargains, sells, aliens, remises, releases, conveys and confirms unto the grantee, all that certain land situate in Polk County, Florida, viz:

Begin at the NW corner of Section 14, Township 29S, Range 24E, Polk County, FL; run N89 deg 51'27"E 600 feet along the North section line, deflect 30 deg right and run a distance of 200 feet, deflect 67 deg 29'03" right and run a distance of 256.48 feet, deflect 41 deg 44'38" right and run a distance of 261.86 feet, deflect 40 deg 54'52" right and run a distance of 437.13 feet, more or less, to a point on the West line of Section 14, deflect 89 deg 22'50" right and run a distance of 523.98 feet along the West line of Section 14 to the NW corner of Section 14 and Point of Beginning

Parcel ID#142924-000000-033030

Together with all the tenements, hereditaments and appurtenances thereto belonging or in anywise appertaining.

To Have and to Hold, the same in fee simple forever.

And the grantor hereby covenants with said grantee that the grantor is lawfully seized of said land in fee simple; that the grantor has good right and lawful authority to sell and convey said land, that the grantor hereby fully warrants the title to said land and will defend the same against the lawful claims of all persons whomsoever, and that said land is free of all encumbrances except taxes accruing subsequent to December 31, 2005.

In Witness Whereof, the said grantor has signed and sealed these presents the day and year first above written.

Signed, sealed and delivered in the presence of:

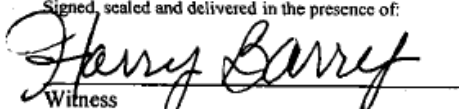
  
Witness

Witness Printed Name Harry Barry

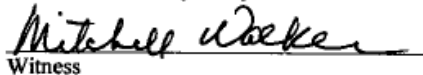
  
Witness

Witness Printed Name Mitchell Walker

  
William Manning

  
Susanne Manning

STATE OF FLORIDA  
COUNTY OF POLK

The foregoing instrument was acknowledged before me this 20<sup>th</sup> day of June, 2006 by William Manning + Susanne Manning, who is personally known to me or has produced his/her driver's license as identification.



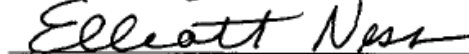

Signature - Notary Public

Print Name: Elliott Ness

My Commission Expires: 7-5-2010

# Interpretation of Real Property Descriptions

This Instrument Prepared By:  
Name: Lakeland Title, Inc.  
Address: 2229 S. Florida Ave.  
Lakeland, FL 33813

## WARRANTY DEED

Made this 8<sup>th</sup> day of January, 2008 A.D. by **Griffin Groves, Inc.** whose post office address is: P.O. Box 551, Lakeland, FL 33813 hereinafter called the Grantor, to **Polk County**, whose post office address is: 222 E. Church St., Bartow, FL 33830, hereinafter called the Grantee:

(Whenever used herein the term "grantor" and "grantee" include all the parties to this instrument and the heirs, legal representatives and assigns of individuals, and the successors and assigns of corporations).

**Witnesseth**, that the grantor, for and in consideration of the sum of Ten Dollars, (\$10.00) and other valuable considerations, receipt whereof is hereby acknowledged, hereby grants, bargains, sells, aliens, remises, releases, conveys and confirms unto the grantee, all that certain land situate in Polk County, Florida, viz:

See attached "Exhibit A" for legal description:

Parcel ID#142924-000000-031010

Together with all the tenements, hereditaments and appurtenances thereto belonging or in anywise appertaining.

To Have and to Hold, the same in fee simple forever.

And the grantor hereby covenants with said grantee that the grantor is lawfully seized of said land in fee simple; that the grantor has good right and lawful authority to sell and convey said land, that the grantor hereby fully warrants the title to said land and will defend the same against the lawful claims of all persons whomsoever, and that said land is free of all encumbrances except taxes accruing subsequent to December 31, 2007.

In Witness Whereof, the said grantor has signed and sealed these presents the day and year first above written.

Signed, sealed and delivered in the presence of:

Pete Rose  
Witness

Witness Printed Name Pete Rose

Edward Miller  
Witness

Witness Printed Name Edward Miller

George Griffin  
George Griffin, President  
Griffin Groves, Inc.

STATE OF FLORIDA  
COUNTY OF POLK

The foregoing instrument was acknowledged before me this 8th day of January, 2008 by George Griffin, President of Griffin Groves, Inc., who is personally known to me or has produced his/her driver's license as identification.



Harry Bennett  
Signature - Notary Public

Print Name: Harry Bennett

My Commission Expires: 2-1-2010

# Interpretation of Real Property Descriptions

---

## Exhibit "A"

### Canterwood Road:

A strip of land 60 feet wide being 30 feet on each side (measured at right angles) of the following described centerline:

Commence at Northwest corner of Section 14, Township 29 South, Range 24 East, Polk County, Florida, thence  $S00^{\circ}37'10''E$  along West line of Section 900 feet to Point of Beginning of centerline of road; thence  $N 55^{\circ}E$  a distance of 155 feet to point of curve concave to the south with Radius of 300 feet, central angle of  $75^{\circ}$ , thence Easterly along said curve an arc distance of 392.70 feet to point of reverse curve concave to the north with Radius of 330 feet, central angle of  $80^{\circ}$ , thence Easterly along said curve an arc distance of 460.77 feet to point of tangency; thence  $N50^{\circ}E$  a distance of 300 feet to point of curve concave southerly with Radius of 300 feet, central angle of  $60^{\circ}$ , thence along said curve an arc distance of 314.16 feet to point of compound curve concave southwesterly with a Radius of 200 feet, a central angle of  $30^{\circ}$ , thence southeasterly along said curve an arc distance of 104.72 feet to point of tangency; thence  $S35^{\circ}E$  a distance of 150 feet to point of curve concave to north with Radius of 350 feet, central angle of  $110^{\circ}$ , thence easterly along said curve an arc distance of 671.95 feet to point of tangency; thence  $N35^{\circ}E$  a distance of 120 feet to point of curve concave southerly with Radius of 150 feet, central angle of  $50^{\circ}$ , thence northeasterly along said curve an arc distance of 130.90 feet to point of tangency; thence  $N85^{\circ}E$  a distance of 276.91 feet to point on east boundary of said Section 14 at a point  $S00^{\circ}36'53''E$  602.31 feet from northeast corner of Section 14 and end of said centerline.

The outside perimeters of the right-of-way are to be extended or shortened as necessary to terminate at the west section line and east line of NW1/4 of Section.

# Interpretation of Real Property Descriptions

This Instrument Prepared By:  
Name: Lakeland Title Inc  
Address: 2229 S. Florida Ave.  
Lakeland, FL 33813

## WARRANTY DEED

Made this 1st day of October, 2004 A.D. by **Peter Piper and Penny Piper, his wife** whose post office address is: - 550 Scott Lake Rd., Lakeland, FL 33813 hereinafter called the Grantor, to **Sunshine Citrus, Inc.**, whose post office address is: 339 Hwy. 60 East, Bartow, FL 33830, hereinafter called the Grantee:

(Whenever used herein the term "grantor" and "grantee" include all the parties to this instrument and the heirs, legal representatives and assigns of individuals, and the successors and assigns of corporations)

**Witnesseth**, that the grantor, for and in consideration of the sum of Ten Dollars, (\$10.00) and other valuable considerations, receipt whereof is hereby acknowledged, hereby grants, bargains, sells, conveys, releases, conveys and confirms unto the grantee, all that certain land situate in Polk County, Florida, viz:

NW1/4 of NW1/4 of Section 14, Township 29 South, Range 24 East, Polk County, Florida, lying north of Canterwood Road, LESS Begin at northwest corner of Section 14, Township 29 South, Range 24 East, thence N89°51'27"E a distance of 600 feet along the north line of section, deflect 30° right and run a distance of 200 feet; deflect 67°29'03" right and run a distance of 256.48 feet; deflect 41°44'381" right and run a distance of 261.86 feet; deflect 40°54'52" right and run a distance of 437.13 feet more or less, to a point on West line of said Section 14; deflect 89°22'50" right and run a distance of 523.98 feet along the west line of said Section 14 to the northwest corner of section and Point of Beginning.

Parcel ID#142924-000000-033100

**Together** with all the tenements, hereditaments and appurtenances thereto belonging or in anywise appertaining.

**To Have and to Hold**, the same in fee simple forever.

**And** the grantor hereby covenants with said grantee that the grantor is lawfully seized of said land in fee simple; that the grantor has good right and lawful authority to sell and convey said land, that the grantor hereby fully warrants the title to said land and will defend the same against the lawful claims of all persons whomsoever, and that said land is free of all encumbrances except taxes accruing subsequent to December 31, 2003.

**In Witness Whereof**, the said grantor has signed and sealed these presents the day and year first above written.

Signed, sealed and delivered in the presence of:

Audrey Meadows  
Witness  
Witness Printed Name Audrey Meadows  
Glenda Johns  
Witness  
Witness Printed Name Glenda Johns

Peter Piper  
Peter Piper

Penny Piper  
Penny Piper

STATE OF FLORIDA  
COUNTY OF POLK

The foregoing instrument was acknowledged before me this 1st day of October, 2004 by Peter Piper and Penny Piper, his wife, who is personally known to me or has produced his/her driver's license as identification.



Peter Lorri  
Signature - Notary Public  
Print Name: Peter Lorri

My Commission Expires: 11/1/2008

# Interpretation of Real Property Descriptions

This Instrument Prepared By:  
Name: Joe Jackson, Attorney at Law  
Address: 4233 Pool Branch Rd  
Homeland, FL 33801

## WARRANTY DEED

Made this 24<sup>th</sup> day of November, 2007 A.D. by Avery Alderman and Brenda Alderman, husband and wife, whose post office address is: 8595 Middlex, Bartow, FL 33830 hereinafter called the Grantor, to Crandon Brock, a single woman, whose post office address is: 34 Devon Ave., Lakeland, FL 33811, hereinafter called the Grantee:

(Whenever used herein the term "grantor" and "grantee" include all the parties to this instrument and the heirs, legal representatives and assigns of individuals, and the successors and assigns of corporations)

Witnesseth, that the grantor, for and in consideration of the sum of Ten Dollars, (\$10.00) and other valuable considerations, receipt whereof is hereby acknowledged, hereby grants, bargains, sells, aliens, remises, releases, conveys and confirms unto the grantee, all that certain land situate in Polk County, Florida, viz:

The SE1/4 of the NW1/4 of Section 14, Township 29 South, Range 24 East, Polk County Florida; Less and except Commence at the Southwest corner of the SE1/4 of the NW1/4 of Section 14, Township 29 South, Range 24 East, thence N 89 deg 46' 35" E 30 feet to the East boundary of Ball Park Road, thence N 00 deg 37' 00"W along the East boundary of said road 475 feet for Point of Beginning; continue N 00 deg 37' 00"W 512.28 feet to a point on the Southwest corner of Highland Terrace Subdivision as recorded in Plat Book 74 page 42 of the Public Records of Polk County, Florida, thence N 69 deg 51'22"E along the South boundary of said subdivision 1635.48 feet to SE corner of said subdivision, thence N 00 deg 36'58"W 339.47 feet to the Northeast corner of said subdivision and to a point on the North boundary of SE1/4 of the NW1/4 of section, thence N89 deg 52' 42"E 300 feet, run thence parallel to the East boundary of SE1/4 of NW1/4 of said Section 14 S 10 deg 36'53"E 850.44 feet, thence S89 deg 46'33"W 935.43 feet to Point of Beginning and less and except Highland Terrace Subdivision as recorded in Plat Book 74 page 42 of the Public Records of Polk County, Florida; and less and except right of way for Ball Park Road and Geiger Road. Parcel ID# 142924-000000-032030

Together with all the tenements, hereditaments and appurtenances thereto belonging or in anywise appertaining.

To Have and to Hold, the same in fee simple forever.

And the grantor hereby covenants with said grantee that the grantor is lawfully seized of said land in fee simple; that the grantor has good right and lawful authority to sell and convey said land, that the grantor hereby fully warrants the title to said land and will defend the same against the lawful claims of all persons whomsoever, and that said land is free of all encumbrances except taxes accruing subsequent to December 31, 2006.

In Witness Whereof, the said grantor has signed and sealed these presents the day and year first above written.

Signed, sealed and delivered in the presence of:

Jerry Bronson  
Witness  
Witness Printed Name: Jerry Bronson  
Jeff Conroy  
Witness  
Witness Printed Name: Jeff Conroy

Avery Alderman  
Avery Alderman  
Brenda Alderman  
Brenda Alderman

STATE OF FLORIDA  
COUNTY OF POLK

The foregoing instrument was acknowledged before me this 24<sup>th</sup> day of November, 2007 by Avery Alderman + Brenda Alderman, who is personally known to me or has produced his/her driver's license as identification.



Robert Clancy  
Signature - Notary Public  
Print Name: Robert Clancy  
My Commission Expires: 1/5/2010



# Interpretation of Real Property Descriptions

This Instrument Prepared By:  
Name: Clouded Title, Inc.  
Address: 447 N. Main St.  
Lakeland, FL 33801

## WARRANTY DEED

Made this 8<sup>th</sup> day of November, 2003 A.D. by **Drew Martin and Mimi Martin, his wife**, whose post office address is: P.O. Box 876, Lakeland, FL 33811 hereinafter called the Grantor, to **Greener Gardens, LLC**, whose post office address is: 228 Sunshine Ct., Bartow, FL 33830, hereinafter called the Grantee:

(Whenever used herein the term "grantor" and "grantee" include all the parties to this instrument and the heirs, legal representatives and assigns of individuals, and the successors and assigns of corporations)

**Witnesseth**, that the grantor, for and in consideration of the sum of Ten Dollars, (\$10.00) and other valuable considerations, receipt whereof is hereby acknowledged, hereby grants, bargains, sells, conveys, releases, conveys and confirms unto the grantee, all that certain land situate in Polk County, Florida, viz:

That part of the following described parcel lying north of Canterwood Road:  
West 12 Acres of NE1/4 of NW1/4 of Section 14, Township 29 South, Range 24 East, Polk County, Florida

Parcel ID#142924-000000-031080

**Together** with all the tenements, hereditaments and appurtenances thereto belonging or in anywise appertaining.

**To Have and to Hold**, the same in fee simple forever.

**And** the grantor hereby covenants with said grantee that the grantor is lawfully seized of said land in fee simple; that the grantor has good right and lawful authority to sell and convey said land, that the grantor hereby fully warrants the title to said land and will defend the same against the lawful claims of all persons whomsoever, and that said land is free of all encumbrances except taxes accruing subsequent to December 31, 2002.

**In Witness Whereof**, the said grantor has signed and sealed these presents the day and year first above written.

Signed, sealed and delivered in the presence of:

Chelsea Stone  
Witness  
Witness Printed Name Chelsea Stone  
Emma Edwards  
Witness  
Witness Printed Name Emma Edwards

Drew Martin  
Drew Martin  
Mimi Martin  
Mimi Martin

STATE OF FLORIDA  
COUNTY OF POLK

The foregoing instrument was acknowledged before me this 8th day of November, 2003 by Drew Martin and Mimi Martin, his wife, who is personally known to me or has produced his/her driver's license as identification.



George Boswick  
Signature - Notary Public  
Print Name: George Boswick  
My Commission Expires: 3/7/2007

# Interpretation of Real Property Descriptions

This Instrument Prepared By:  
Name: Joan Maxwell  
Address: 1850 Tarah Trace Drive  
Brandon, FL 33510

## WARRANTY DEED

Made this 15<sup>th</sup> day of January, 2009 A.D. by **Matthew Clark**, a single man whose post office address is: 165 N. 16<sup>th</sup> St., Lakeland, FL 33801 hereinafter called the Grantor, to **Thomas Maxwell and Joan Maxwell, his wife** whose post office address is: 1850 Tarah Trace Drive, Brandon, FL 33510, hereinafter called the Grantee:

(Whenever used herein the term "grantor" and "grantee" include all the parties to this instrument and the heirs, legal representatives and assigns of individuals, and the successors and assigns of corporations)

**Witnesseth**, that the grantor, for and in consideration of the sum of Ten Dollars, (\$10.00) and other valuable considerations, receipt whereof is hereby acknowledged, hereby grants, bargains, sells, conveys, releases, conveys and confirms unto the grantee, all that certain land situate in Polk County, Florida, viz:

That part of the SW1/4 of the NW1/4 and the NW1/4 of the NW1/4 of Section 14, Township 29 South, Range 24 East, Polk County, Florida, being bounded on the north by the southerly line of the 60 foot right-of-way of Canterwood Road, bounded on the west by a line 715 feet east of and parallel with the west line of said Section 14, bounded on the east by the east line of the NW1/4 of the NW1/4 and the east line of the SW1/4 of NW1/4 of said Section 14, and bounded on the south by the south line of the N1/2 of the SW1/4 of the NW1/4 of said Section 14.

Parcel ID# 142924-000000-033010

**Together** with all the tenements, hereditaments and appurtenances thereto belonging or in anywise appertaining.

**To Have and to Hold**, the same in fee simple forever. The grantor hereby covenants with said grantee that the grantor is lawfully seized of said land in fee simple; that the grantor has good right and lawful authority to sell and convey said land, that the grantor hereby fully warrants the title to said land and will defend the same against the lawful claims of all persons whomsoever, and that said land is free of all encumbrances except taxes accruing subsequent to December 31, 2008.

**In Witness Whereof**, the said grantor has signed and sealed these presents the day and year first above written.

Signed, sealed and delivered in the presence of:

Tim McVay  
Witness

Witness Printed Name: Tim McVay

Tula Turner  
Witness

Witness Printed Name: Tula Turner

Matthew Clark  
Matthew Clark

STATE OF FLORIDA  
COUNTY OF POLK

The foregoing instrument was acknowledged before me this 15<sup>th</sup> day of January, 2009 by Thomas Maxwell and Joan Maxwell, his wife, who is personally known to me or has produced his/her driver's license as identification.



Deborah Mathis

Signature - Notary Public

Print Name: Deborah Mathis

My Commission Expires: 5/1/2011

# Interpretation of Real Property Descriptions

This Instrument Prepared By:  
Name: Wishy Washy Title  
Address: PO Box 212  
Lakeland, FL 33811

## WARRANTY DEED

Made this 6<sup>th</sup> of September, 2005 A.D. by **Terry Thomas & Toni Thomas, his wife** whose post office address is: - 5595 County Rd. 37, Lakeland, FL 33813, hereinafter called the Grantor, to **James Jankowski and Angela Jankowski, his wife**, whose post office address is: 665 Southview Dr., Bartow, FL 33830, hereinafter called the Grantee:

(Whenever used herein the term "grantor" and "grantee" include all the parties to this instrument and the heirs, legal representatives and assigns of individuals, and the successors and assigns of corporations)

**Witnesseth**, that the grantor, for and in consideration of the sum of Ten Dollars, (\$10.00) and other valuable considerations, receipt whereof is hereby acknowledged, hereby grants, bargains, sells, aliens, remises, releases, conveys and confirms unto the grantee, all that certain land situate in Polk County, Florida, viz:

One (1) Acre in the SE corner of the S1/2 of the SW1/4 of NW1/4 of Section 14, Township 29 South, Range 24 East, Polk County, Florida.

Parcel ID# 142924-000000-034070

**Together** with all the tenements, hereditaments and appurtenances thereto belonging or in anywise appertaining.



**To Have and to Hold**, the same in fee simple forever.

**And** the grantor hereby covenants with said grantee that the grantor is lawfully seized of said land in fee simple; that the grantor has good right and lawful authority to sell and convey said land, that the grantor hereby fully warrants the title to said land and will defend the same against the lawful claims of all persons whomsoever, and that said land is free of all encumbrances except taxes accruing subsequent to December 31, 2004.

**In Witness Whereof**, the said grantor has signed and sealed these presents the day and year first above written.

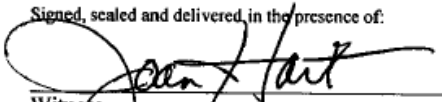
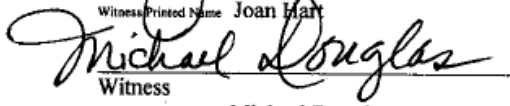
Signed, sealed and delivered, in the presence of:

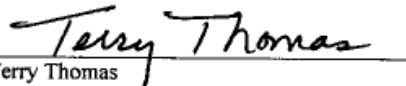
  
Witness  
Witness Printed Name: Joan Hart  
  
Witness  
Witness Printed Name: Michael Douglas

  
Terry Thomas  
  
Toni Thomas

STATE OF FLORIDA  
COUNTY OF POLK

The foregoing instrument was acknowledged before me this 6<sup>th</sup> day of September, 2005 by Terry Thomas and Toni Thomas, his wife, who is personally known to me or has produced his/her driver's license as identification.

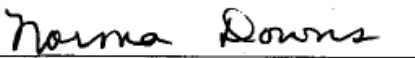

  
Signature - Notary Public  
Print Name: Norma Downs

My Commission Expires: 10-1-2008

# Interpretation of Real Property Descriptions

This Instrument Prepared By:  
Name: Common Ground Title  
Address: P.O. Box 990  
Lakeland, FL 33811

## WARRANTY DEED

Made this 5<sup>th</sup> day of May, 2007 A.D. by **Simple Solutions, LLC**, whose post office address is: P.O. Box 2298, Lakeland, FL 33801 hereinafter called the Grantor, to **Patricia Bailey, a single woman**, whose post office address is: 559 S. Lemon St., Lakeland, FL 33801, hereinafter called the Grantee:

(Whenever used herein the term "grantor" and "grantee" include all the parties to this instrument and the heirs, legal representatives and assigns of individuals, and the successors and assigns of corporations)

**Witnesseth**, that the grantor, for and in consideration of the sum of Ten Dollars, (\$10.00) and other valuable considerations, receipt whereof is hereby acknowledged, hereby grants, bargains, sells, aliens, remises, releases, conveys and confirms unto the grantee, all that certain land situate in Polk County, Florida, viz:

That part of West 715 feet of NW1/4 of NW1/4 of Section 14, Township 29 South, Range 24 East, Polk County, Florida, lying south of Canterwood Road, LESS West 50 feet thereof.

Parcel ID#142924-000000-033090

Together with all the tenements, hereditaments and appurtenances thereto belonging or in anywise appertaining.

To Have and to Hold, the same in fee simple forever.

And the grantor hereby covenants with said grantee that the grantor is lawfully seized of said land in fee simple; that the grantor has good right and lawful authority to sell and convey said land, that the grantor hereby fully warrants the title to said land and will defend the same against the lawful claims of all persons whomsoever, and that said land is free of all encumbrances except taxes accruing subsequent to December 31, 2006.

In Witness Whereof, the said grantor has signed and sealed these presents the day and year first above written.

Signed, sealed and delivered in the presence of:

Penny Pratt  
Witness

Witness Printed Name: Penny Pratt

Minnie Clark  
Witness

Witness Printed Name: Minnie Clark

George Grant  
George Grant, President  
Simple Solutions, LLC

STATE OF FLORIDA  
COUNTY OF POLK

The foregoing instrument was acknowledged before me this 5th day of May, 2007 by George Grant, President of Simple Solutions, LLC, who is personally known to me or has produced his/her driver's license as identification.



James Thurber  
Signature - Notary Public  
Print Name: James Thurber

My Commission Expires: 7/2/2009

# Interpretation of Real Property Descriptions

This Instrument Prepared By:  
Name: Twisted Title, Inc.  
Address: 5590 S. Orange Ave.  
Lakeland, FL 33801

## WARRANTY DEED

Made this 5<sup>th</sup> day of July, 2006 A.D. by **Robert Jones and Sylvia Jones, his wife**, whose post office address is: 557 16<sup>th</sup> Street, Lakeland, FL 33815 hereinafter called the Grantor, to **Charles Churchill, a single man**, whose post office address is: 33 Hemphill Road, Bartow, FL 33830, hereinafter called the Grantee:

(Whenever used herein the term "grantor" and "grantee" include all the parties to this instrument and the heirs, legal representatives and assigns of individuals, and the successors and assigns of corporations)

**Witnesseth**, that the grantor, for and in consideration of the sum of Ten Dollars, (\$10.00) and other valuable considerations, receipt whereof is hereby acknowledged, hereby grants, bargains, sells, conveys, releases, conveys and confirms unto the grantee, all that certain land situate in Polk County, Florida, viz:

S1/2 of SW1/4 of NW1/4 of Section lying West of Saddle Creek and That part of the West 715 feet of the N1/2 of SW1/4 of NW1/4 lying West of Saddle Creek and The West 50 feet of NW1/4 of Section lying North of Saddle Creek and South of Canterwood Road, all lying in Section 14, Township 29 South, Range 24 East, Polk County, Florida.

Parcel ID#142924-000000-034030

**Together** with all the tenements, hereditaments and appurtenances thereto belonging or in anywise appertaining.

**To Have and to Hold**, the same in fee simple forever.

And the grantor hereby covenants with said grantee that the grantor is lawfully seized of said land in fee simple; that the grantor has good right and lawful authority to sell and convey said land, that the grantor hereby fully warrants the title to said land and will defend the same against the lawful claims of all persons whomsoever, and that said land is free of all encumbrances except taxes accruing subsequent to December 31, 2005.

**In Witness Whereof**, the said grantor has signed and sealed these presents the day and year first above written.

Signed, sealed and delivered in the presence of:

Dianne Pines  
Witness  
Witness Printed Name Dianne Pines  
Debbie Scott  
Witness  
Witness Printed Name Debbie Scott

Robert Jones  
Robert Jones  
Sylvia Jones  
Sylvia Jones

STATE OF FLORIDA  
COUNTY OF POLK

The foregoing instrument was acknowledged before me this 5<sup>th</sup> day of July, 2006 by Robert Jones and Sylvia Jones, his wife, who is personally known to me or has produced his/her driver's license as identification.



Cary Caudill  
Signature - Notary Public  
Print Name: Cary Caudill  
My Commission Expires: 8/12/09

# Interpretation of Real Property Descriptions

This Instrument Prepared By:  
Name: Lakeland Title Inc  
Address: 2229 S. Florida Ave.  
Lakeland, FL 33813

## WARRANTY DEED

Made this 10<sup>th</sup> day of April, 2008 A.D. by **Arthur Austin, a single man** whose post office address is: 558 Hardwick Road, Lakeland, FL 33819 hereinafter called the Grantor, to **Sunshine Citrus, Inc.**, whose post office address is: 339 Hwy. 60 East, Bartow, FL 33830, hereinafter called the Grantee:

(Whenever used herein the term "grantor" and "grantee" include all the parties to this instrument and the heirs, legal representatives and assigns of individuals, and the successors and assigns of corporations)

**Witnesseth**, that the grantor, for and in consideration of the sum of Ten Dollars, (\$10.00) and other valuable considerations, receipt whereof is hereby acknowledged, hereby grants, bargains, sells, aliens, remises, releases, conveys and confirms unto the grantee, all that certain land situate in Polk County, Florida, viz:

That part of the following described property lying north of Canterwood Road:  
NE1/4 of NW1/4 of Section 14, Township 29 South, Range 24 East, Polk County, Florida  
Less West 12 Acres.

Parcel ID#142924-000000-031020

**Together** with all the tenements, hereditaments and appurtenances thereto belonging or in anywise appertaining.

**To Have and to Hold**, the same in fee simple forever.

**And** the grantor hereby covenants with said grantee that the grantor is lawfully seized of said land in fee simple; that the grantor has good right and lawful authority to sell and convey said land, that the grantor hereby fully warrants the title to said land and will defend the same against the lawful claims of all persons whomsoever, and that said land is free of all encumbrances except taxes accruing subsequent to December 31, 2007.

**In Witness Whereof**, the said grantor has signed and sealed these presents the day and year first above written.

Signed, sealed and delivered in the presence of:

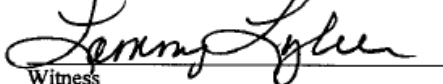
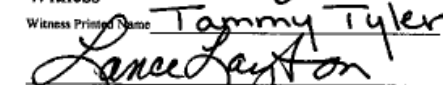
  
Witness  
Witness Printed Name Tammy Tyler  
  
Witness  
Witness Printed Name Lance Layton

  
Arthur Austin

STATE OF FLORIDA  
COUNTY OF POLK

The foregoing instrument was acknowledged before me this 10th day of April, 2008 by Arthur Austin, who is personally known to me or has produced his/her driver's license as identification.

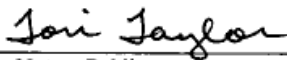

  
Signature - Notary Public  
Print Name: Tori Taylor  
My Commission Expires: 9/2/10

# Interpretation of Real Property Descriptions

This Instrument Prepared By:  
Name: Lakeland Title Inc  
Address: 2229 S. Florida Ave.  
Lakeland, FL 33813

## WARRANTY DEED

Made this 6<sup>th</sup> day of March, 2008 A.D. by **Kevin Pearce and Christy Pearce, his wife**, whose post office address is: 993 Juniper Dr., Bartow, FL 33830, hereinafter called the Grantor, to **Griffin Groves, Inc.**, whose post office address is: P.O. Box 551, Lakeland, FL 33813, hereinafter called the Grantee:

(Whenever used herein the term "grantor" and "grantee" include all the parties to this instrument and the heirs, legal representatives and assigns of individuals, and the successors and assigns of corporations)

**Witnesseth**, that the grantor, for and in consideration of the sum of Ten Dollars, (\$10.00) and other valuable considerations, receipt whereof is hereby acknowledged, hereby grants, bargains, sells, aliens, remises, releases, conveys and confirms unto the grantee, all that certain land situate in Polk County, Florida, viz:

That part of the following described parcel lying south of Canterwood Road:  
NE1/4 of NW1/4 of Section 14, Township 29 South, Range 24 East, Polk County, Florida

Parcel ID#142924-000000-031070

**Together** with all the tenements, hereditaments and appurtenances thereto belonging or in anywise appertaining.

**To Have and to Hold**, the same in fee simple forever.

And the grantor hereby covenants with said grantee that the grantor is lawfully seized of said land in fee simple; that the grantor has good right and lawful authority to sell and convey said land, that the grantor hereby fully warrants the title to said land and will defend the same against the lawful claims of all persons whomsoever, and that said land is free of all encumbrances except taxes accruing subsequent to December 31, 2007.

**In Witness Whereof**, the said grantor has signed and sealed these presents the day and year first above written.

Signed, sealed and delivered in the presence of:

Becky Bryant  
Witness

Witness Printed Name Becky Bryant

John Stoddard  
Witness

Witness Printed Name John Stoddard

Kevin Pearce  
Kevin Pearce

Christy Pearce  
Christy Pearce

STATE OF FLORIDA  
COUNTY OF POLK

The foregoing instrument was acknowledged before me this 6th day of March, 2008 by , Kevin Pearce and Christy Pearce, his wife, who is personally known to me or has produced his/her driver's license as identification.



John Stoddard  
Signature - Notary Public

Print Name John Stoddard

My Commission Expires: 5/7/10

# Interpretation of Real Property Descriptions

This Instrument Prepared By:  
Name: Common Ground Title LLC  
Address: 626 Orange Ave.  
Orlando, FL 36902

## WARRANTY DEED

Made this 5<sup>th</sup> day of June, 2004 A.D. by **Willard Wilson, a single man**, whose post office address is: 65 Sunshine Road, Lakeland, FL 33812 hereinafter called the Grantor, to **Phillip Jones, a single man**, whose post office address is: 2234 Turner Road, Tampa, FL 33619, hereinafter called the Grantee:

(Whenever used herein the term "grantor" and "grantee" include all the parties to this instrument and the heirs, legal representatives and assigns of individuals, and the successors and assigns of corporations)

**Witnesseth**, that the grantor, for and in consideration of the sum of Ten Dollars, (\$10.00) and other valuable considerations, receipt whereof is hereby acknowledged, hereby grants, bargains, sells, conveys, releases, conveys and confirms unto the grantee, all that certain land situate in Polk County, Florida, viz:

South ½ of the Southwest ¼ of the Northwest ¼ of Section 14, Township 29 South, Range 24 East, Polk County, Florida, lying East of Saddle Creek LESS One (1) Acre in the SE corner said 1 acre being described as 208.71 feet square.

Parcel ID# 142924-000000-034020

**Together** with all the tenements, hereditaments and appurtenances thereto belonging or in anywise appertaining.

**To Have and to Hold**, the same in fee simple forever.

**And** the grantor hereby covenants with said grantee that the grantor is lawfully seized of said land in fee simple; that the grantor has good right and lawful authority to sell and convey said land, that the grantor hereby fully warrants the title to said land and will defend the same against the lawful claims of all persons whomsoever, and that said land is free of all encumbrances except taxes accruing subsequent to December 31, 2003.

**In Witness Whereof**, the said grantor has signed and sealed these presents the day and year first above written.

Signed, sealed and delivered in the presence of:

Bonnie Edwards  
Witness

Witness Printed Name: Bonnie Edwards

Clyde Edwards  
Witness

Witness Printed Name: Clyde Edwards

Willard Wilson  
Willard Wilson

STATE OF FLORIDA  
COUNTY OF POLK

The foregoing instrument was acknowledged before me this 5<sup>th</sup> day of June, 2004 by Willard Wilson, who is personally known to me or has produced his/her driver's license as identification.



June Jacobson  
Signature Notary Public  
Print Name June Jacobson

My Commission Expires: 11/1/07



# Interpretation of Real Property Descriptions

This Instrument Prepared By:  
Name: Florida Title, Inc.  
Address: P.O. Box 778  
Lakeland, FL 33801

## WARRANTY DEED

Made this 9<sup>th</sup> day of August, 2007 A.D. by **Stephen Siler and Rebecca Siler, his wife**, whose post office address is: P.O. Box 2291, Lakeland, FL 33811 hereinafter called the Grantor, to **Kevin Kline and Patsy Kline, his wife**, whose post office address is: 668 Oak St. W., Bartow, FL 33830, hereinafter called the Grantee:

(Whenever used herein the term "grantor" and "grantee" include all the parties to this instrument and the heirs, legal representatives and assigns of individuals, and the successors and assigns of corporations)

**Witnesseth**, that the grantor, for and in consideration of the sum of Ten Dollars, (\$10.00) and other valuable considerations, receipt whereof is hereby acknowledged, hereby grants, bargains, sells, conveys, releases, conveys and confirms unto the grantee, all that certain land situate in Polk County, Florida, viz:

West 715 feet of North 1/2 of SW1/4 of NW1/4 of Section 14, Township 29 South, Range 24 East, Polk County, Florida, LESS that part lying southwesterly of Saddle Creek, and LESS West 50 feet thereof.

Parcel ID#142924-000000-034050

**Together** with all the tenements, hereditaments and appurtenances thereto belonging or in anywise appertaining.

**To Have and to Hold**, the same in fee simple forever.

And the grantor hereby covenants with said grantee that the grantor is lawfully seized of said land in fee simple; that the grantor has good right and lawful authority to sell and convey said land, that the grantor hereby fully warrants the title to said land and will defend the same against the lawful claims of all persons whomsoever, and that said land is free of all encumbrances except taxes accruing subsequent to December 31, 2006.

**In Witness Whereof**, the said grantor has signed and sealed these presents the day and year first above written.

Signed, sealed and delivered in the presence of:

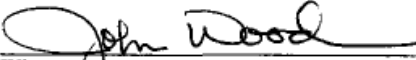
  
Witness

Witness Printed Name John Wood

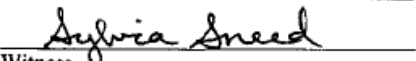
  
Witness

Witness Printed Name Sylvia Sneed

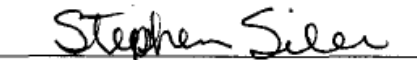
  
Stephen Siler

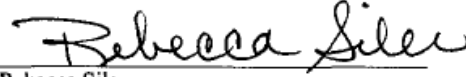
  
Rebecca Siler

STATE OF FLORIDA  
COUNTY OF POLK

The foregoing instrument was acknowledged before me this 9th day of August, 2007 by Stephen Siler and Rebecca Siler, his wife, who is personally known to me or has produced his/her driver's license as identification.

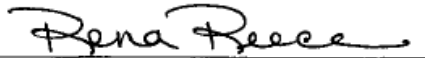

  
Signature - Notary Public

Print Name: Rena Reece

My Commission Expires: 2/5/09





# QUIZ ANSWERS

# Interpretation of Real Property Descriptions

---

## Day One – Fundamentals Quiz Answers

1. How would you describe a property description?  
**A picture in words**
2. According to Wattles, what must a “legal” description be able to do?  
**Withstand attack under law**
3. An **adjoinder description** describes a parcel of land totally by reference to other parcels already on record in the public repository.
4. A **metes and bounds** description provides the direction and distance of each course around a figure and relates the monuments that control that figure.
- 5.A **subdivision** uses solely the name of the parcels as shown on a recorded document that divided a larger parcel in accordance with state law.
6. What are the names of the two projections used for the Florida State Plane Coordinate system?  
**Lambert Conformal Conic & Transverse Mercator**
7. What projection would you utilize for the panhandle portion of the state of Florida?  
**Lambert Conformal Conic**
8. In the coordinate system a rectangular grid is developed that covers an entire state or a portion of a state, this grid is called a **zone**.
9. A description using calls to adjoining titles and boundaries and which also contains bearings and distances in order to describe a parcel would be called **combination** description.
10. Word meaning “touching or contiguous”. **Adjoining**
11. Word meaning “lying near or close to”. **Adjacent**
12. The Army Corps of Engineers counts **North** as zero azimuth and increases the degrees **clockwise** .
13. Grid bearings are based on those bearings one computes when using **State Plane Coordinates** .

## Interpretation of Real Property Descriptions

---

14. **True** bearings are generally considered to be based on astronomical bearings and are based on “sun shots” or “star shots.”
15. What words are used in property descriptions to cover slight or unimportant inaccuracies in quantity? **More or Less**
16. The **initial point** in the description shall be tied to either a government corner, a recorded corner, or some other well-established survey point.
17. A reciting of a line by metes and bounds together with the widths of the parcel being included on one or both sides and that does not return to the point of beginning is an example of what type of description? **Strip**
18. What term generally means the entire parcel is limited by the rights described. **Reserved**

# Interpretation of Real Property Descriptions

---

## Day One - Metes & Bounds Quiz Answers

1. The walking and transfer of objects from the lands involved was called the action of **livery of seizen**.
2. The description that makes calls to adjacent land owners, trees, rocks, rivers, traveled ways, and so forth used to describe the perimeter of the property, is known as a **Reference Description**.
3. The type of description used to describe land in the original thirteen colonies, Kentucky, Texas, West Virginia, Tennessee, Maine, Hawaii and parts of Ohio was the **metes and bounds description**.
4. What is the type of description that will include a full heading and caption, recital of all ties and monuments, whether record or physical, **all** references to adjacent lands by name and record, and a full dimensional recital of the boundary courses in succession, and which must be mathematically correct.  
**Combined Description**
5. Items such as metal pipes, steel pins, or concrete posts are known as **Artificial permanent monuments**.
6. What must every metes and bounds description have in order to be valid?  
**Point of Beginning**
7. What is the part of a metes and bounds description that is normally used to ordinate the reader to the general area of the lands to be included with in the description and serves as a legal limit to the lands conveyed? **Caption**.
8. A Gunter's chain is **100** links long and **66** feet in length.
9. If the basis of bearing was found on a survey it would be found in which part?  
**Closing or Qualification**.
10. The portion of a metes and bounds description that gets the reader from the Point of Commencement to the Point of Beginning. **Heading**
11. A Point of Commencement is necessary in every metes and bounds description.  
TRUE                      FALSE

## Interpretation of Real Property Descriptions

---

12. That portion of a metes and bounds description that generally contains all the various calls around the lands to be included within the description.

**Body**

13. What is the angle between the meridian and the line measured from either the north or south toward the east or west called? **A Bearing**

14. In the United States a bearing in a property description will *never* exceed 90°. **TRUE FALSE**

15. A link in a Gunter's chain is equal to **7.92** inches.

16. A bearing is *always* given *from* the north or south *to* the east or west. **TRUE FALSE**

17. Which type of angle is measured between a line and the prolongation of the preceding line? **Deflection angle**

18. The common unit of measurement in surveying boundaries in the 1800's was **the Gunter's chain.**

19. Angles to the left are measured **counterclockwise** from the preceding line.

20. A survey based on a state plane coordinate system uses which type of meridian as the reference meridian? **Grid Meridian**



# Interpretation of Real Property Descriptions

---

## Day Two - Curves Quiz Answers

1. The **radius** is the distance from a point on the curve to the center of the circle.
2. The **intersection angle** is always equal to the delta angle in a tangent curve.
3. Which angle is equal to one-half of the delta angle? **Deflection angle**
4. How many elements of the arc of a curve are necessary in order to plot the curve?  
**Two elements**
5. A group of two or more segments of arcs that have a common radial line at the point of contact, have different lengths of radius, and the radius points are on the same side of the curves are called what type of curve? **Compound Curve**
6. A **spiral curve** is a collective group of multiple compound curves having radii of successively decreasing or increasing lengths.
7. **Concavity** relates to the enclosed side of a curve toward the center of the circle.
8. A single segment of arc of a circle is called a **simple curve** .
9. The meeting of two curves or a curve and a straight line having the same general direction is called a cusp. **TRUE FALSE**
10. Concavity relates to the outside face of the curve. **TRUE FALSE**
11. What is the name of the angles between the tangent and the chord?  
**Deflection angles**
12. The intersection of the tangents and the radii at the P.C. and the P.T. are always **right angles (90°)** .
13. How many total elements are needed in order to plot a curve?  
**Five – of which two would be elements of the arc of the curve**
14. What does the abbreviation P.C.C. stand for?  
**Point of Compound Curve**
15. What does the abbreviation P.R.C. stand for?  
**Point of Reverse curve**

## Interpretation of Real Property Descriptions

---

16. The concavity direction of a curve is that of the directions of the center of the circle of said curve from the **mid-point** of the arc described.
17. A **radial line** is a line drawn from a point on an arc to the arc's radius point.
18. What is another term for a broken-back curve?  
**Non-tangent curve**
19. What is the term used for the center of a circle?  
**Radius Point**
20. Name the five elements of a curve.  
**Radius, Arc length, delta angle (or central angle), tangent, and chord**

# Interpretation of Real Property Descriptions

---

## Day Three - Subdivision & Strip Quiz Answers

1. Which chapter of the Florida Statutes regulates the platting of land?  
**Chapter 177, Part I**
2. If the beginning and terminating lines are not called out in the description then what would you do?  
**Assume they are 90 degrees from the beginning and terminating points**
3. The accuracy of the plat's perimeter is under the preview of the Minimum Technical Standards for Surveys in Florida.  
**TRUE      FALSE**
4. Governments use the **platting process** as a means to control what is happening in their jurisdiction.
5. What part of the plat will tell you whether the streets depicted in the plat are public streets or private streets? **Dedication**
6. A metes and bounds description that does not return to the point of beginning and states a side with on both sides of a centerline would be what type of description?  
**Strip**
7. If you have a description for a centerline that does not state any side widths what would you do?  
**Contact the preparer of the document and notify them of the failure to include that information.**
8. You should always verify that the **drawing** of the subdivision is exactly what is described in the plat legal description.
9. What is the bearing of a line called that is between two monuments or corners and which serves as the reference bearing for all other lines on the survey? **Basis of Bearing**
10. If a strip description starts with "A 20 foot strip lying along the front lot line of Lot 20 ...." how would you determine where the "front lot line" was?  
**Determine which lot line fronts on the street and that is the front lot line**

# Interpretation of Real Property Descriptions

---

## Day Three - Stationing Quiz Answers

1. Your survey shows a fence line starting at station 50 + 22.1 and going to station 80 + 38.5. What length of fence (in feet) is needed? **3016.4 feet**
2. Stations usually will be **100** feet apart on a right-of-way map.
3. What angle is usually shown on a centerline right-of-way sketch that will mean that there is a curve in the right-of-way?  
**deflection angle**
4. The starting point of the traverse is usually called **Station 0**.
5. Every 100 foot length is a full station and any fractional distance is called **the plus**.
6. A station 120,000 feet from the base point will be shown as station **1200 + 00**.
7. Stations will always start with 0 + 00.  
TRUE            FALSE

---

### Use the following information to answer questions 8 through 15:

The maintained right-of way map you are reviewing starts at station 10 + 00 and ends at station 91 + 23.44. There are stations noted that show the location of an intersection of Deerview Drive at 38 + 23.44, the location of a change in width at 48 + 62.66, the beginning of a curve (PC) at station 54 + 75.23, the location of a power pole is noted at 58 + 2.99, 40' rt., and the location in a change in direction of the right-of-way at station 82 + 59.78. If necessary, sketch the map on a separate piece of paper and answer questions 8 thru 15 below:

8. What is the distance between the end of the centerline of right-of-way and the PC of curve? **3648.21 feet**
9. What is the distance between the beginning station and the intersection with Deerview Drive? **2823.44 feet**
10. What is the distance between the change in width of the road and the PC of curve?  
**612.57 feet**

## Interpretation of Real Property Descriptions

---

11. What is the distance between the intersection with Deerview Drive and the change in direction of the right-of-way? **4436.34 feet**
12. What is the distance between the change in width of the road and the end of the right-of-way line? **4260.78 feet**
13. What is the distance between the beginning of the right-of-way line and the end of the right-of way line? **8123.44 feet**
14. What is the distance between the intersection with Deerview Drive and the PC of curve? **1651.79 feet**
15. The power pole is located **40** feet to the **right** of station 58 + 2.99 and is **90** degrees from said station.

## Interpretation of Real Property Descriptions

---

### Day Three - Property Appraiser Mapping - Quiz Answers

1. The Mapping Requirements under 12D-1.009 of the F.A.C. state that property ownership maps should show the dimensions and acreage, where known, on all parcels over **one acre** in size.
2. Under 12D-8.008(2)(e) of the F. A. C. every parcel number should be **unique**.
3. What is the reasoning behind the abbreviations to be used in legal descriptions listed under 12D-8.008(2)(d) of the F.A.C.?  
**Uniformity on the tax roll**
4. What is the abbreviation to be used for the word 'fractional'?  
**fracl**
5. Which Florida Statute covers listing all property on the tax roll?  
**F.S. 193.085**
6. The title block on a cadastral map may include the following: Acreage, parcel number, parcel dimensions.  
**TRUE    FALSE**  
*(The title block includes such items as county and state names, scale, north arrow, legend, plot date, disclaimer, and map index)*
7. What five cartographic elements should appear on all cadastral maps in order to facilitate functionality?  
**North arrow, scale representation, title block, map date, disclaimer**
8. List five different types of lines that may be shown on a cadastral map.  
**Lot lines, parcel lines, block lines, easement lines, right-of-way lines, hydrographic lines**

# Interpretation of Real Property Descriptions

---

## Day Four - Resolving Problems Quiz Answers

1. The distance of 0.3048 meters exactly is the length of an **International** foot.
2. The degrees used in most north American descriptions are called **Sexagesimal**.
3. The type of curve that says a one degree curve has the long chord length of 100 feet is termed the **Railroad Definition** curve.
4. What is the acceptable ratio of error in the state of Florida for urban areas?  
**1 foot in 10,000 feet or 1:10000**
5. On a hot summer day a metal tape measurement will cause the metal to **expand** and therefore the measurement will actually be **shorter**.
6. A call to the boundary of a parcel as described in OR Book 5682 Page 1256 would take precedence to a call to the shoreline of the Gulf of Mexico.  
**TRUE            FALSE**
7. A call to 4" x 4" concrete monument takes precedence over the distance of 200 feet called for in the deed.  
**TRUE            FALSE**
8. A description which calls for the "Northerly 50 feet of Lot 10" should measure the 50 feet from the **North** boundary of the lot.
9. Which are the most common two elements of a curve from which all other elements of the curve are calculated? **Radius and Delta Angle**
10. What is the term used to describe the probable intentions of the grantor and grantee as determined from the document itself. **Intent**
11. The term that means that one cannot sell something twice is called **Senior Rights**.
12. If you are having a problem with a description that simply does not "work" who should you call? **The Author of the Description**

# Day One – Scale and Protractor Answers

*(Note: your answers may be slightly different, when printing the line may distort slightly from one printer to another – but it should be close!)*

**Page 50:**

1. 660 ft
2. 1880 ft
3. 114 ft
4. 193 ft
5. 6350 ft

**Page 51 & 52**

1. 590 ft
2. 1170 ft
3. 285 ft
4. 1860 ft
5. 2580 ft
6. 2780 ft
7. 880 ft
8. 1990 ft
9. 1030 ft
10. 410 ft

**Page 55:** 78°

**Page 56:** 95°

**Page 57:** 20°

**Page 58:** 58°



# **Day Two - Curve Mapping & Exercise Solutions**

# Interpretation of Real Property Descriptions

---

1.

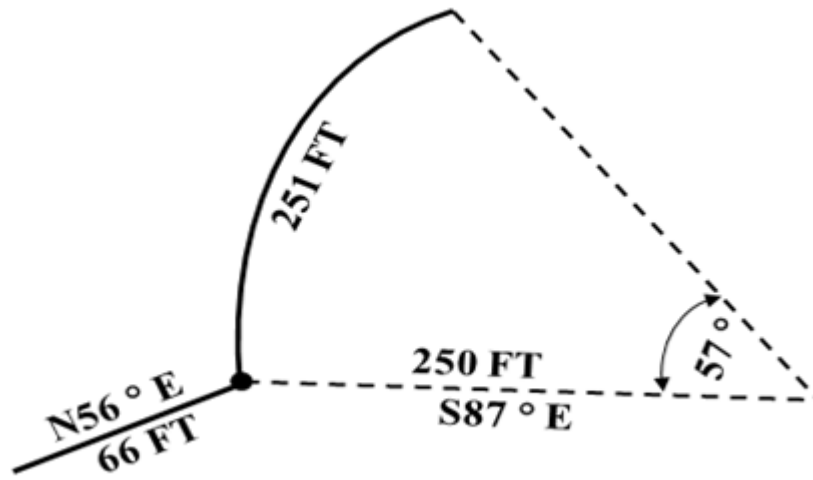

2.

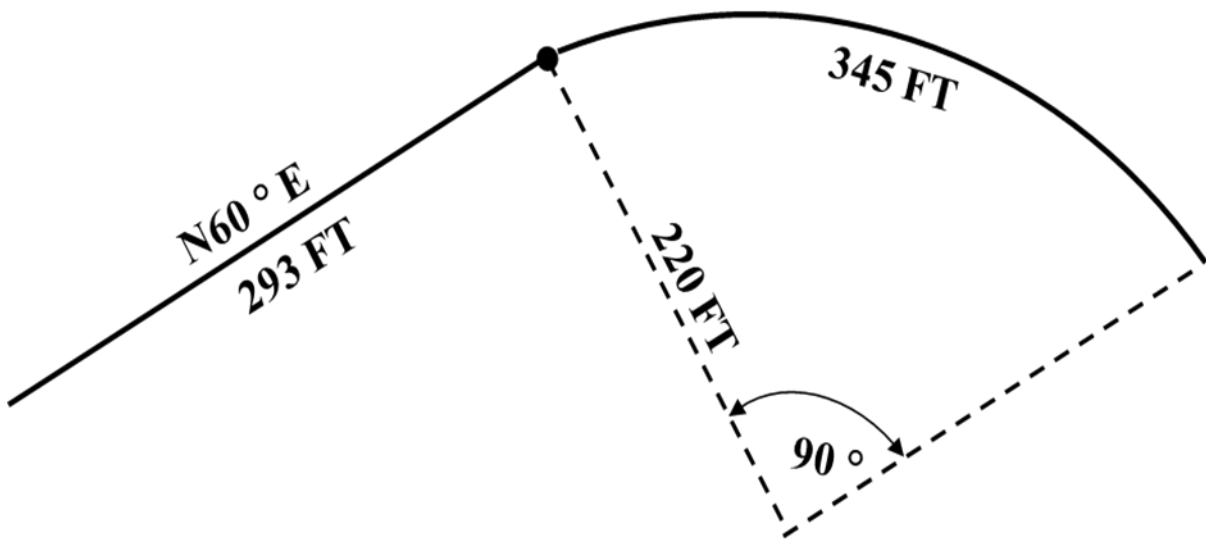

# Interpretation of Real Property Descriptions

---

3.

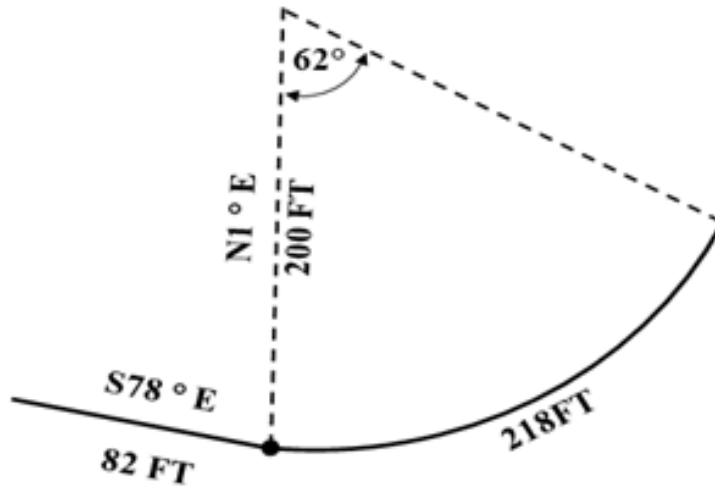

4.

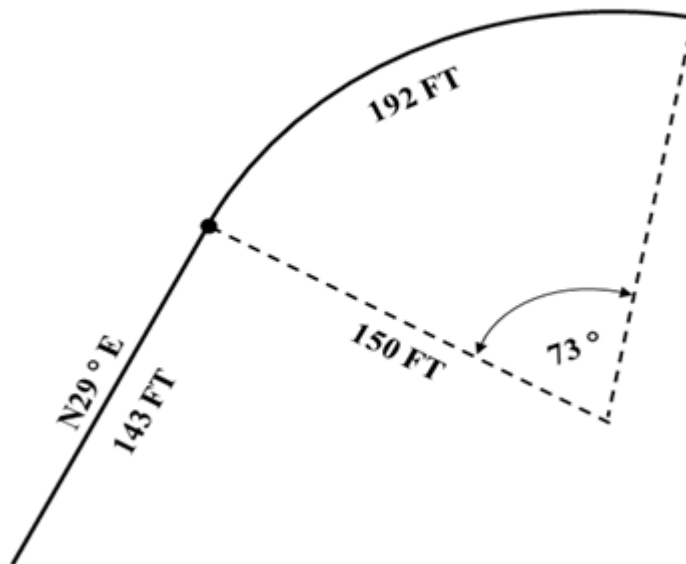

# Interpretation of Real Property Descriptions

---

5.

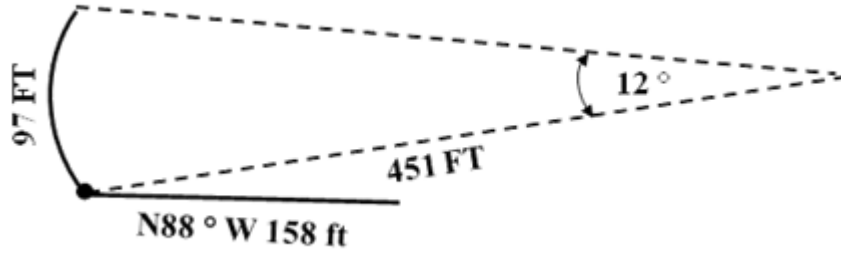

6.

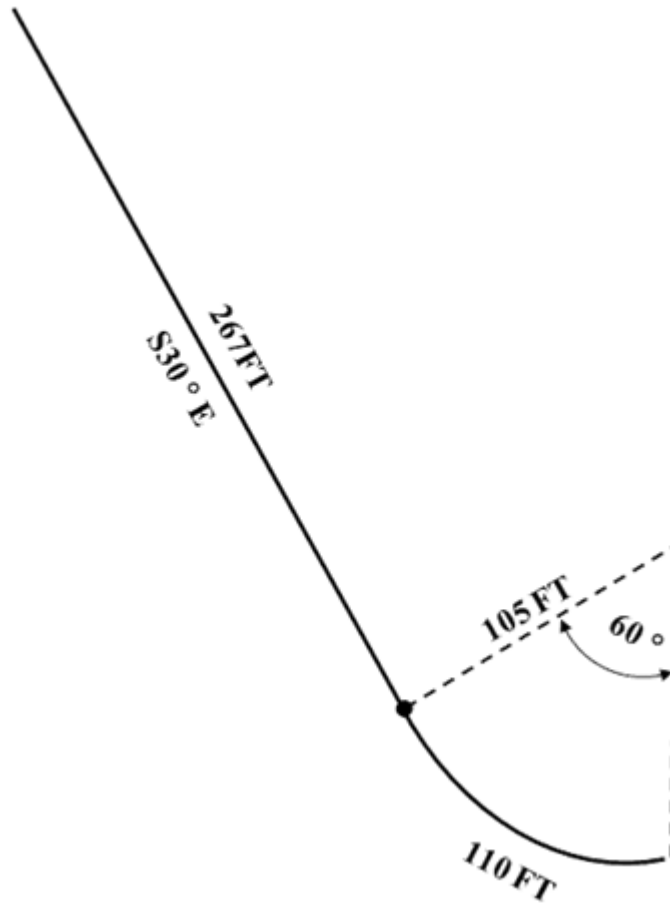

# Interpretation of Real Property Descriptions

---

7.

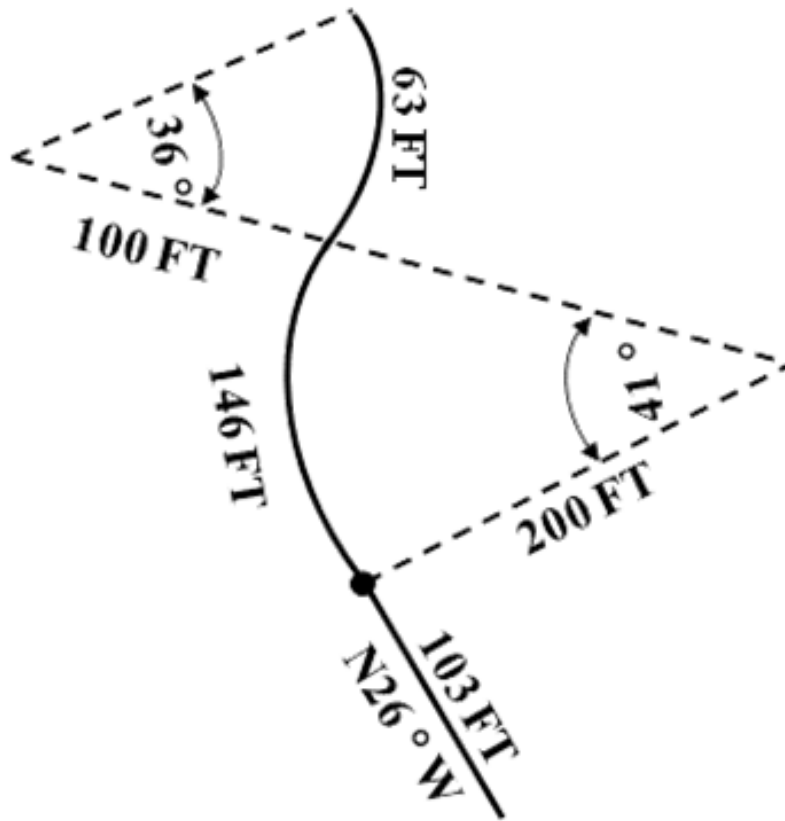

8.

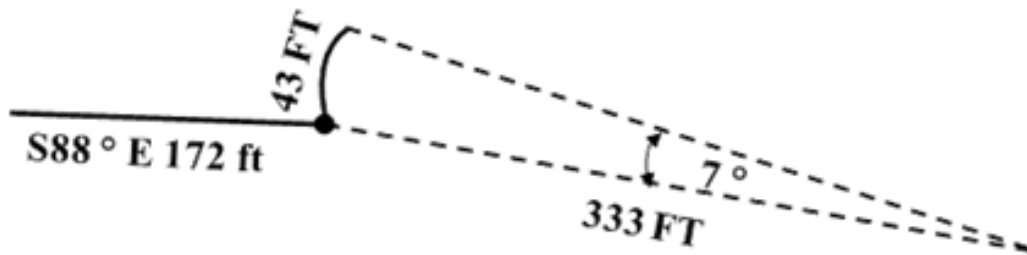

# Interpretation of Real Property Descriptions

---

9.

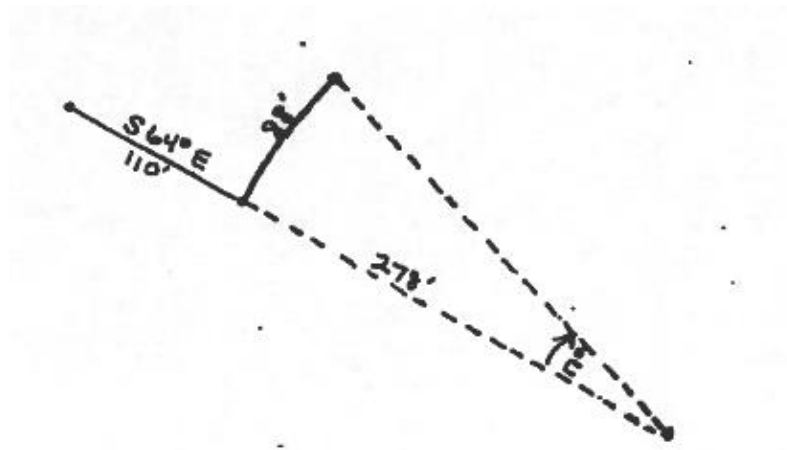

10.

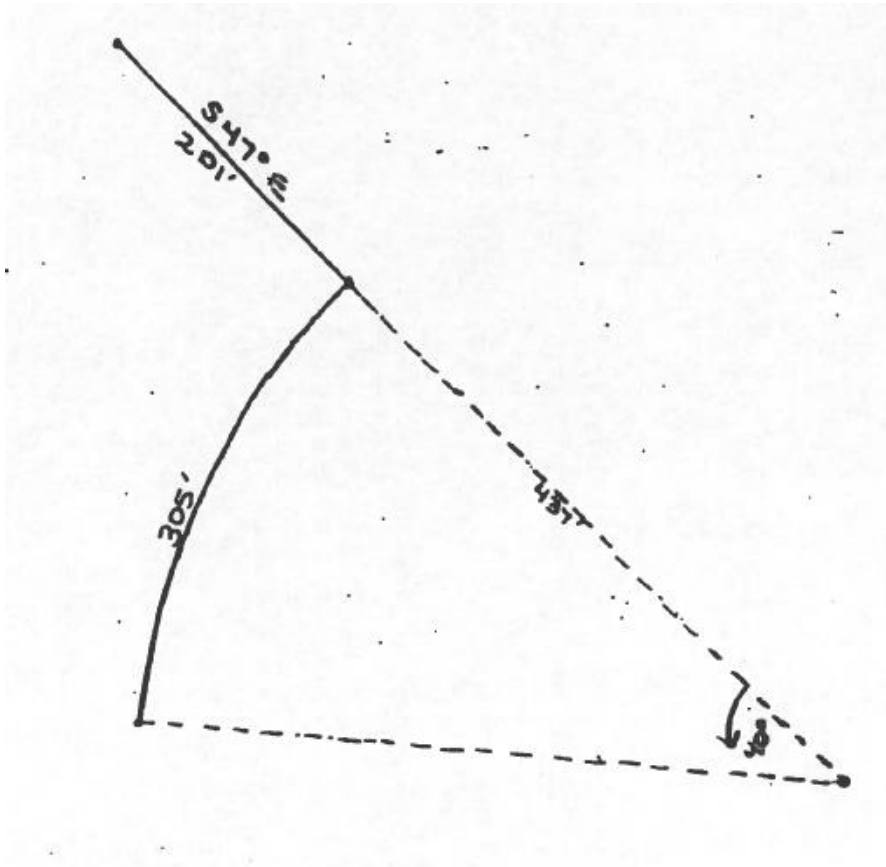

# Interpretation of Real Property Descriptions

11.

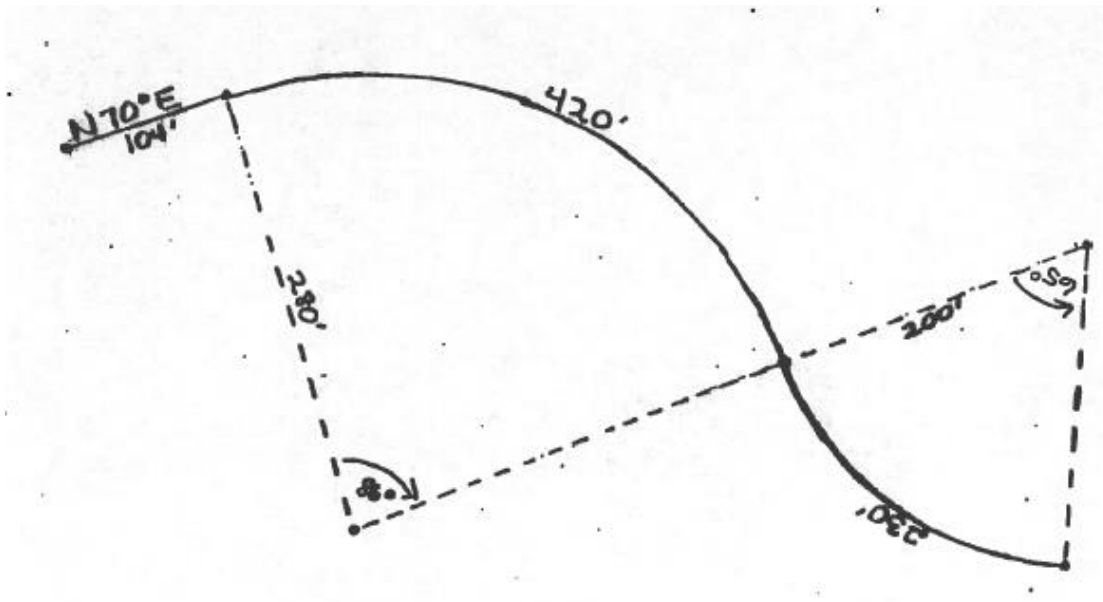

12.  $1''=20'$  scale

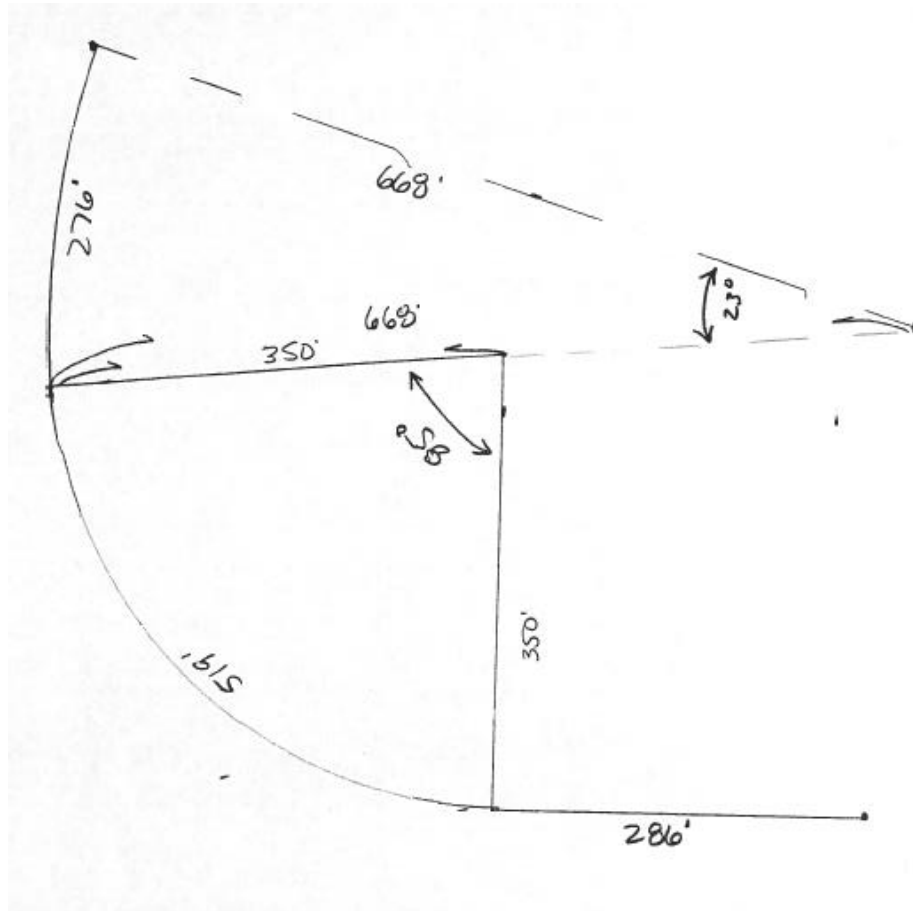

# Interpretation of Real Property Descriptions

## Curve Exercise Answers – Pages 88-96

### Problem 1

Radius = 4  
Tangent = 6  
PC = 2  
PT = 8  
Central Angle = 7  
Arc Length = 1  
PI = 5  
Long Chord = 3

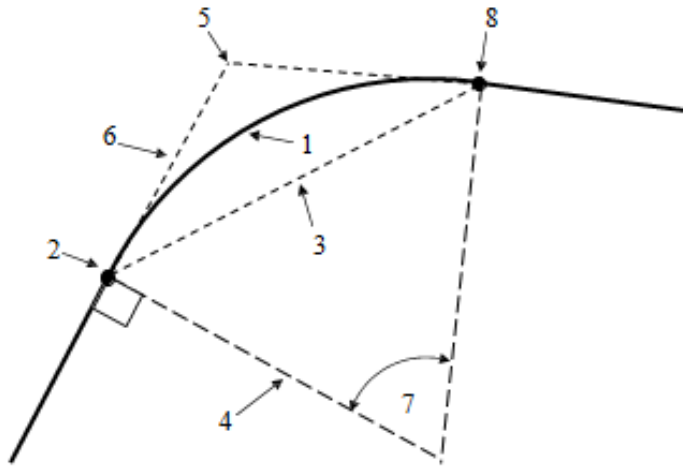

### Problem 2

Given:  
Delta Angle =  $68^{\circ}58'50''$   
Degree of Curve =  $02^{\circ}00'00''$   
PI Station =  $1383 + 97.79$

Radius = 2,864.79  
Tangent = 1,968.20  
PC =  $1364+29.59$   
PT =  $1398+78.62$   
Arc Length = 3,449.03  
Deflection Angle =  $34^{\circ}29'25''$   
Long Chord = 3,244.47

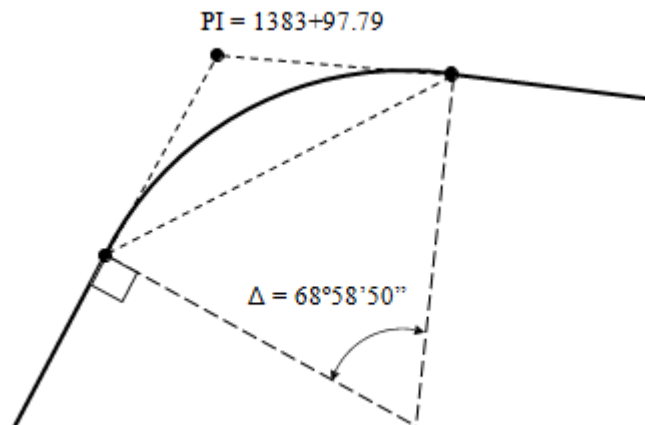



# Interpretation of Real Property Descriptions

## Problem 3

Given:

Radius: 11459.16

Delta Angle =  $09^{\circ}55'00''$

PI Station = 1269 + 63.78

Degree of Curve =  $00^{\circ}30'00''$

Arc Length = 1,983.33'

Tangent = 994.15'

Long Chord = 1,980.86'

Sector Area = 11363671.06 sq. ft

PC = 1259+69.63

PT = 1279+52.96

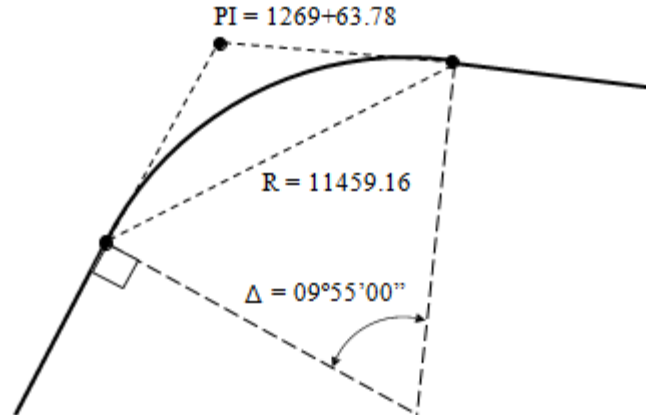

=====

## Problem 4

Given:

Tangent = 771.36'

Delta =  $43^{\circ}59'10''$

Tangent Bearing (Curve Right) = N 03-20-34E

PC Station = 1339+29.69

Degree of Curve =  $03^{\circ}00'00''$

Arc Length = 1,466.20

Long Chord = 1,430.46

Radius = 1909.85

Chord Bearing = N25°20'09"E

PT = 1353+95.89

PI = 1347+01.05

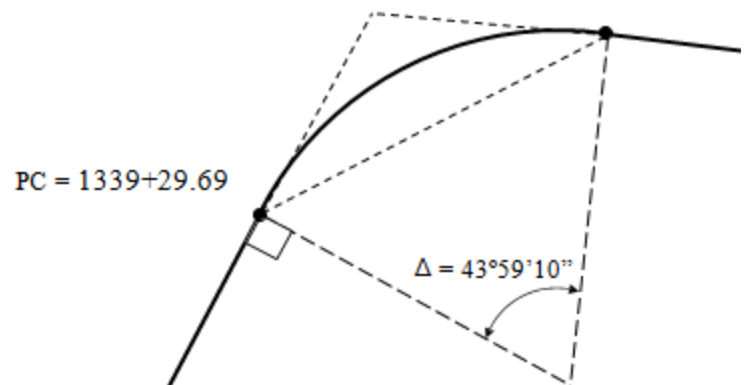

# Interpretation of Real Property Descriptions

---

## 5. Curve Exercise

Given:  
Radius = 1145.92'  
Delta = 20°00'00"  
PI Station = 10+57.23

Degree of Curve = 05°00'00"  
Arc Length = 400.00'  
Tangent = 202.06'  
Long Chord = 397.97'  
Sector Area = 229,184.88  
PC Station = 8+55.17

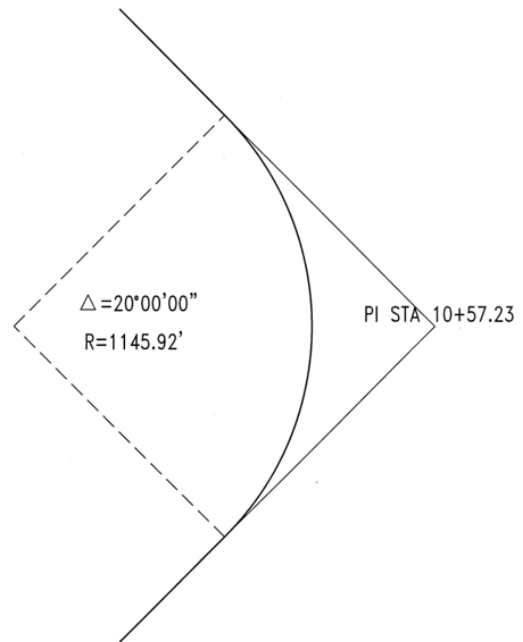

---

## 6. Curve Exercise

Given:  
Radius = 1243.33'  
Delta = 46°36'25"

Degree of Curve = 04°36'30"  
Arc Length = 1,011.36'  
Tangent = 535.55'  
Long Chord = 983.73'  
Fillet Area = 37,125.76

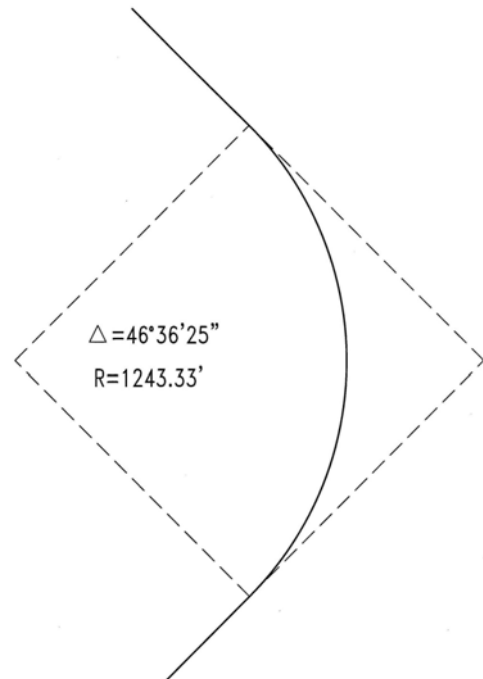

# Interpretation of Real Property Descriptions

---

## 7. Curve Exercise

Given:

Radius = 1109.32'

Delta =  $65^{\circ}25'49''$

PI Station = 587+56.87

Degree of Curve =  $05^{\circ}09'54''$

Arc Length = 1266.80'

Tangent = 712.59'

Long Chord = 1,199.09'

Segment Area = 143,067.15

PT Station = 593+11.08

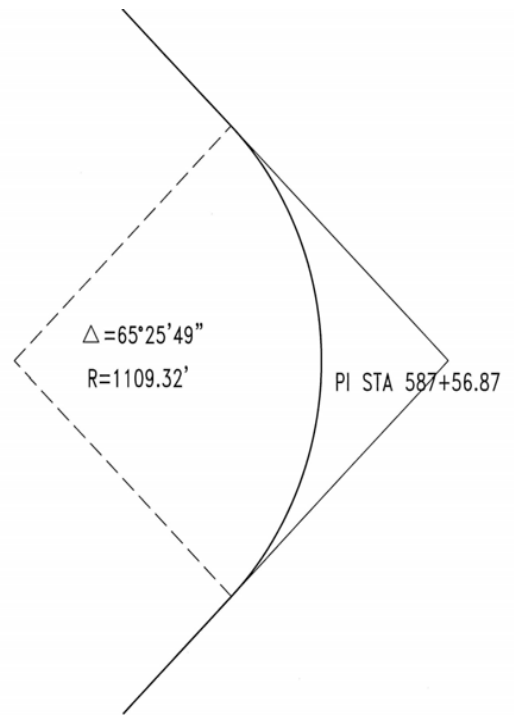

Day Two – Curve Homework Answers

Compound Curve Problem #1

Solve for all unknown curve elements and label all points on the sketch.

**P<sup>1</sup> Curve**  
 $D_c = 11^\circ 27' 32''$   
 $D\angle = 30^\circ$

**P<sup>2</sup> Curve**  
 $\Delta = 30^\circ$   
 $D_c = 28^\circ 38' 52''$   
 $D\angle = 15^\circ$   
 Ch.Brg. =  $S75^\circ W$   
 $T = 53.59'$

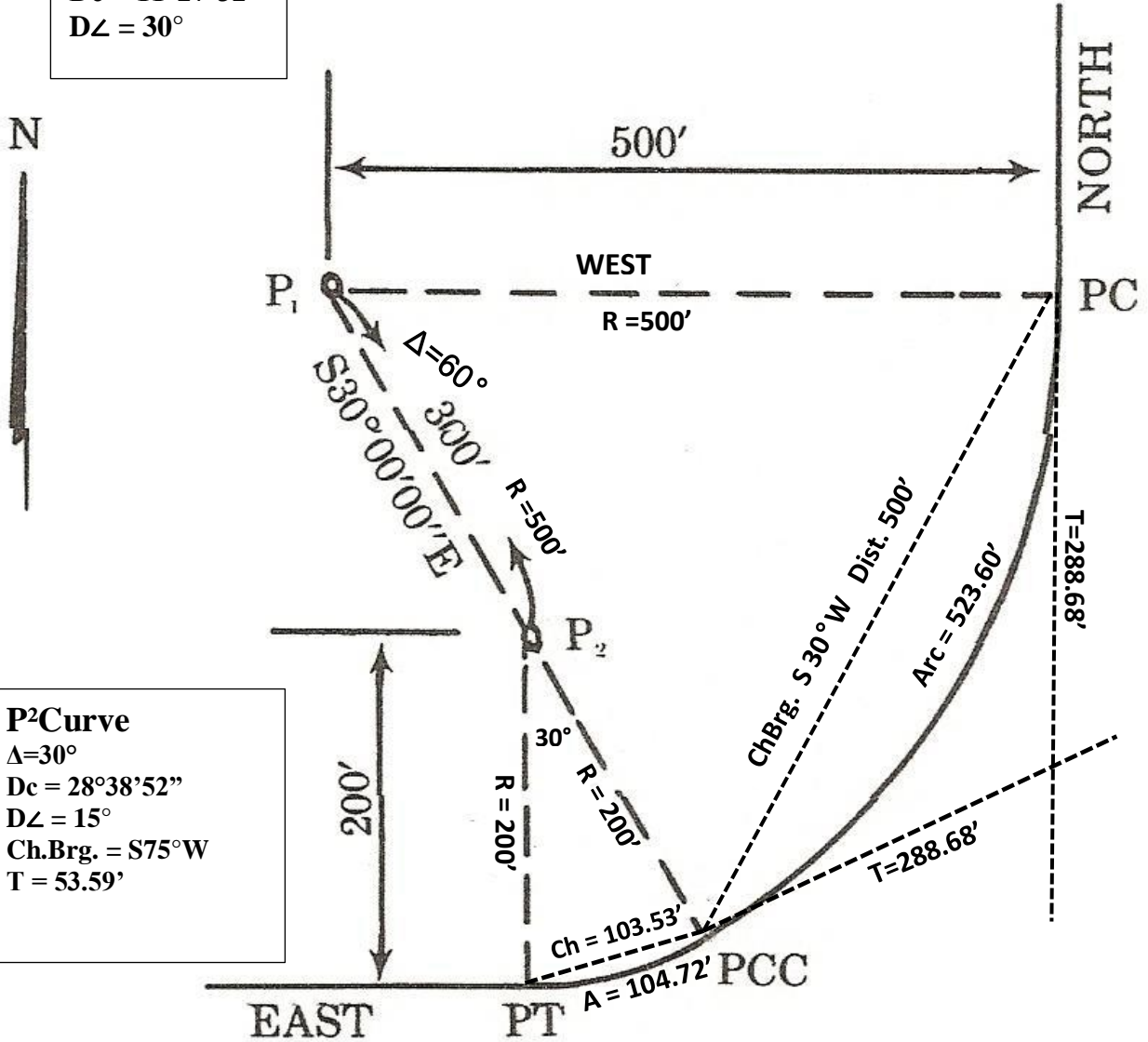

**Reverse Curve Problem #1**

Solve for all unknown curve elements and label all points on this sketch.

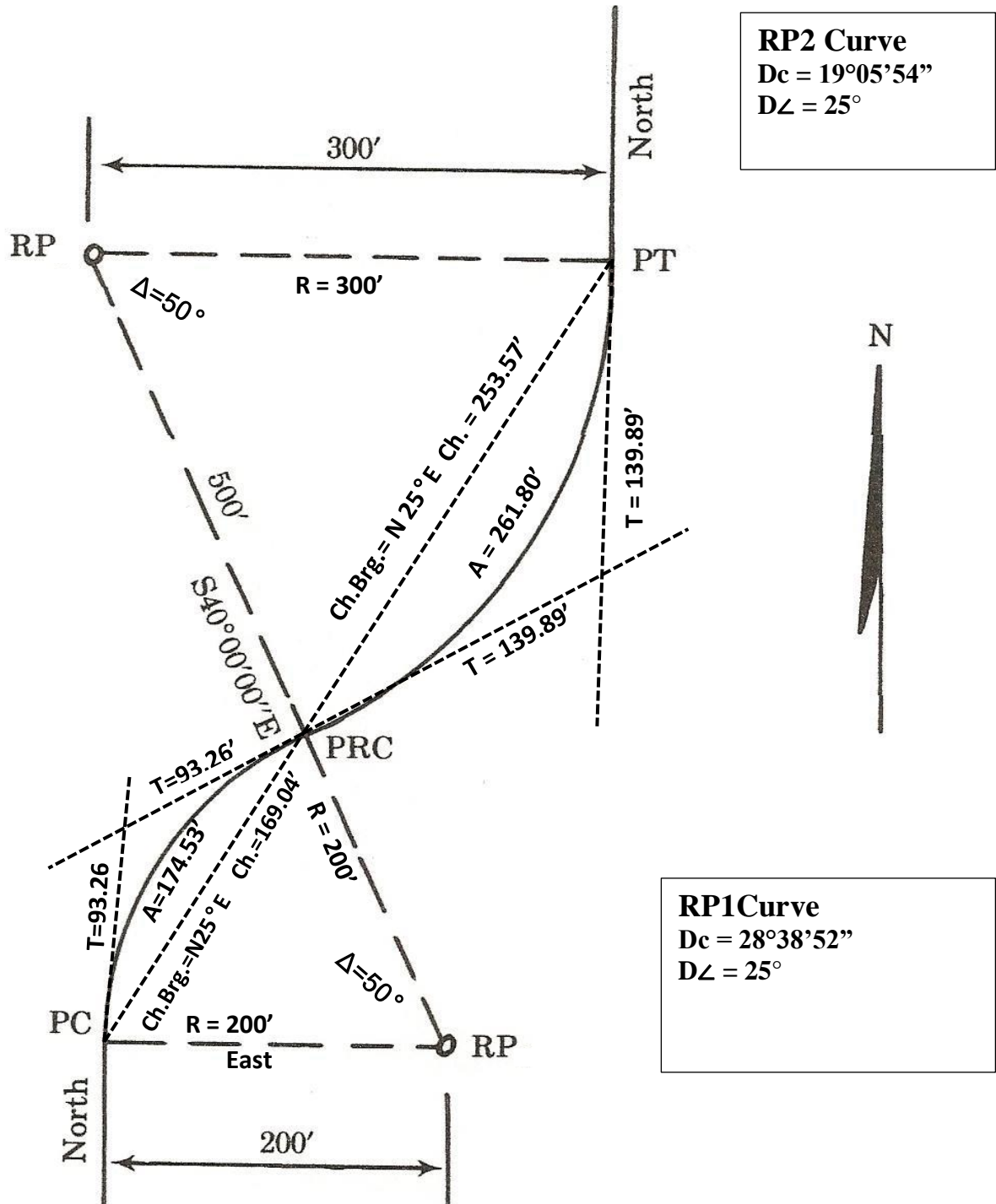

## Day 3 Stationing on Curves Homework Answers

Identify parts of Curve 1 and Sketch parts and identify parts of Curve 2

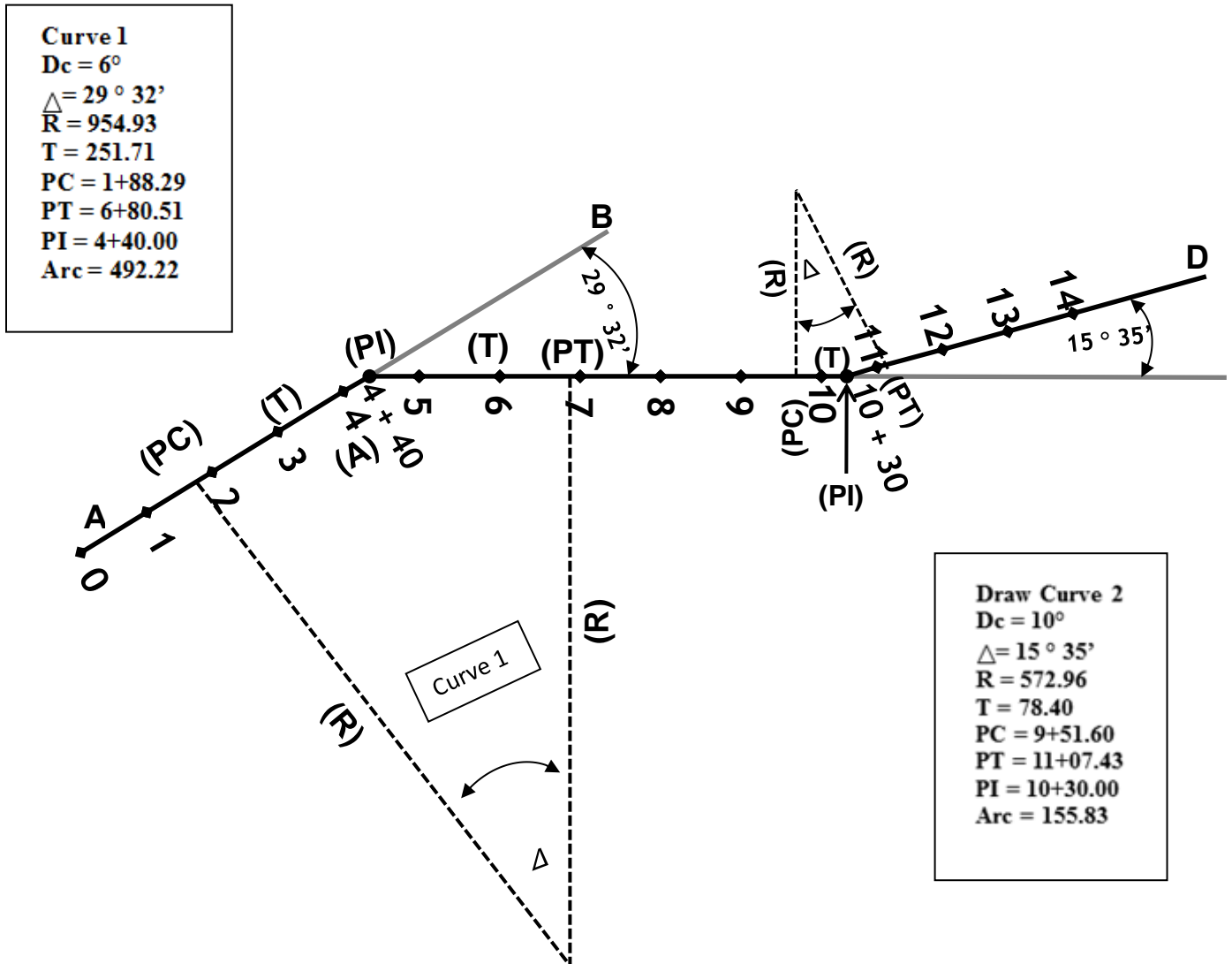

# Interpretation of Real Property Descriptions

---

## Summary of Legal Descriptions

### Perimeter Descriptions

Bounds Descriptions - perimeter descriptions without a direction of travel.

Metes Descriptions - perimeter descriptions with a direction of travel described by a series of measurements.

**Metes and Bounds Descriptions** - Not included in the types described in this document. Perimeter descriptions with a direction of travel described by a series of measurements and calls to endpoints.

### Strip Descriptions

Strip Descriptions - description of a centerline with an offset on either side can also be a radial description with a center point and a distance or radius around the point. Sometimes stationing is provided along the line with the offset along the stationing.

### Area Descriptions

Descriptions by Reference - Reference to a recorded map or plat. These are common "area descriptions". The map or plat contains the linear measurements necessary to describe the areas.

Sectionalized Descriptions - Sectionalized descriptions are based on divisions of the Public Land Survey System. The size and shape of areas are based the rules of division of the PLSS.

### Other Descriptions

Description by Calls - Description by reference to physical objects. These are sometimes called deed calls or running out the calls.

Description by Division Line - This is a division of an existing or previously defined area, such as a lot or a PLSS Section, dividing by a described line. This type of description always creates a remainder or other area that must be described as well. The line may be a measurement, such as metes or a natural feature, such as call to a river or a road. This is a combination description because an area must be identified and then divided.

Description by Distance - This is a division of an existing or previously defined area, such as a lot, by dividing by a described line. This type of description always creates a remainder or other area that must be described as well. The distance is usually specified with respect to an existing boundary, such as the North 50 feet of a lot.

Descriptions by Proportional Conveyances - This is a division of an existing or previously defined area by specifying a proportion of area, such as half or quarter. This type of description always creates a remainder or other area that must be described as well. Proportional conveyances are not the same as sectional descriptions of the PLSS.

## Interpretation of Real Property Descriptions

---

**Description by Exception** - This is a division of an existing or previously defined area, and then excepting out an area. The exception can be any exempt area. This type of description always creates a remainder or other area that must be described

**Description by Acreage** - This is a division of an existing or previously defined area, such as a lot or a PLSS Section, by specifying an area amount. This is similar to the proportional area, except the amount of acreage being described is stated such as 10 acres.

**Ambiguous Descriptions** - These are descriptions of areas or extents of land that cannot be solved without significant research into the intent of the parties participating in the description and subsequent conveyance.



# Interpretation of Real Property Descriptions

---

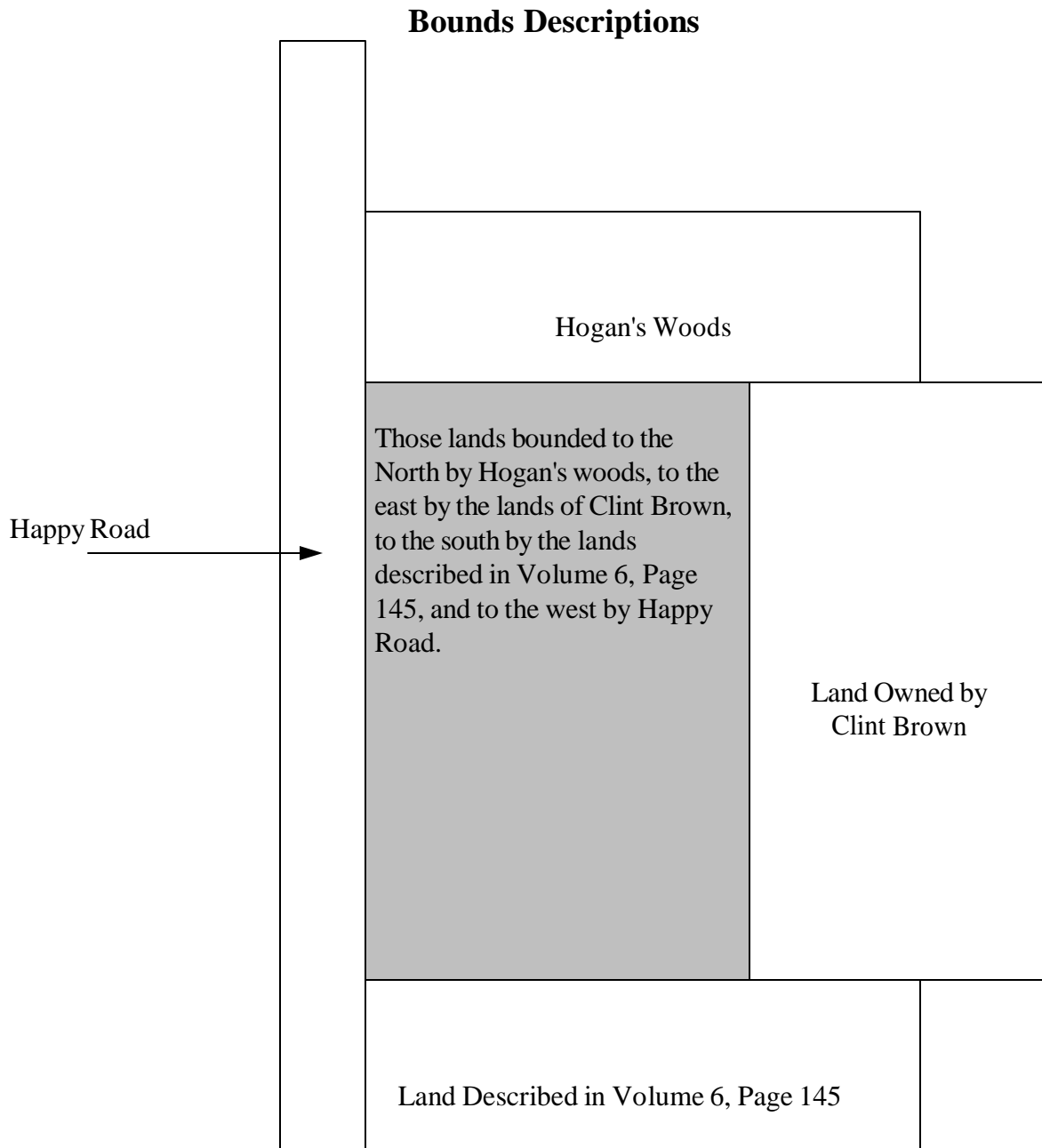

**Bounds descriptions** - perimeter descriptions without a direction of travel.

Problems include:

1. Finding the adjoiner lands or bounds and locating them,
2. Uncertainty in locating where the adjoiner or bounding lands are located with respect to the current parcel. For example in the example above, does the described land extend to the center of the road or the edge of the road.

## Metes Descriptions

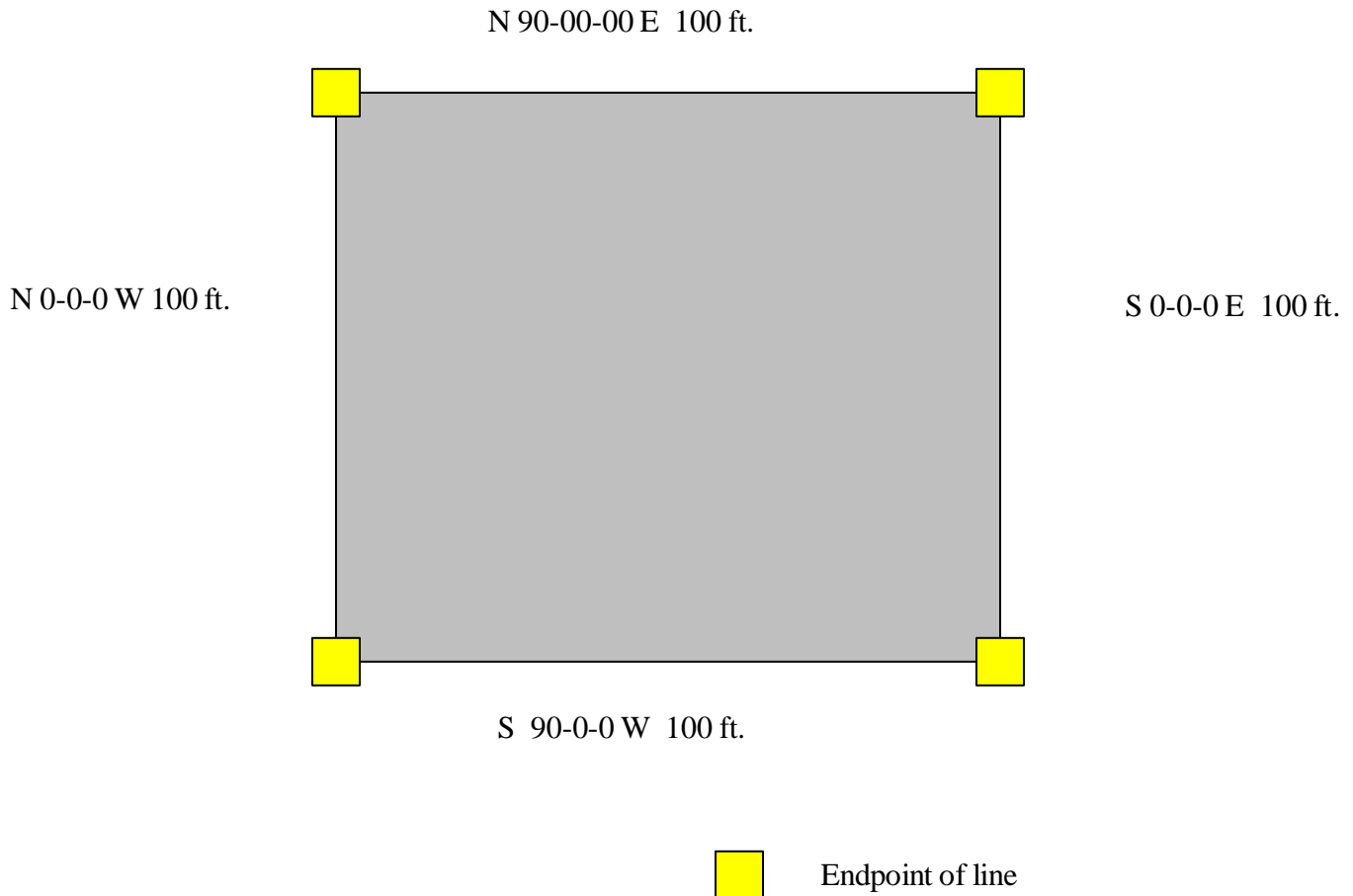



**Metes descriptions** - perimeter descriptions with a direction of travel described by a series of measurements.

Problems include:

1. Measurements may not form a closed area,
2. Uncertainty in determining the basis of bearing for the directions
3. Uncertainty of the units of measure for lengths or distances

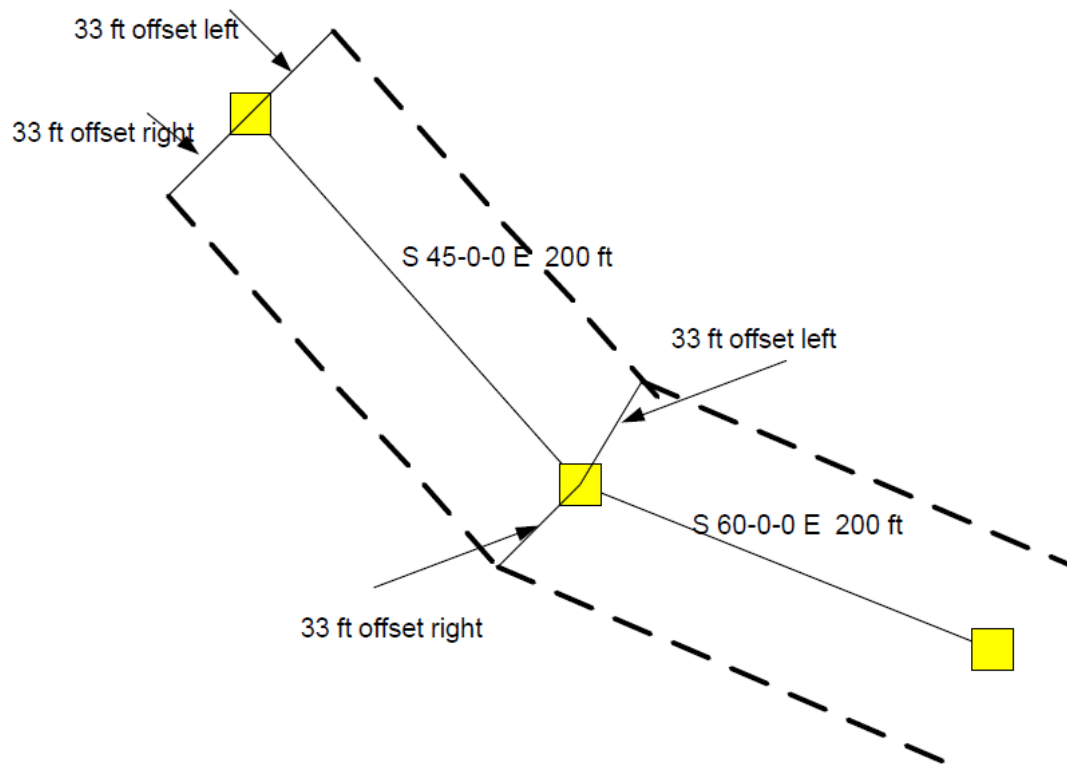
## Strip Descriptions



 Starting point for descriptions

**Strip descriptions** - description of a centerline with an offset on either side. Can also be a radial description with a center point and a distance or radius around the point. Sometimes stationing is provided along the line with the offset along the stationing.

Problems include:

6. Determining the location and centerline,
7. Determining the shape and location of the ends of the strip
8. Handling stationing especially if it is based on project locations and not referenced to a real world location.

# Interpretation of Real Property Descriptions

## Descriptions by Reference

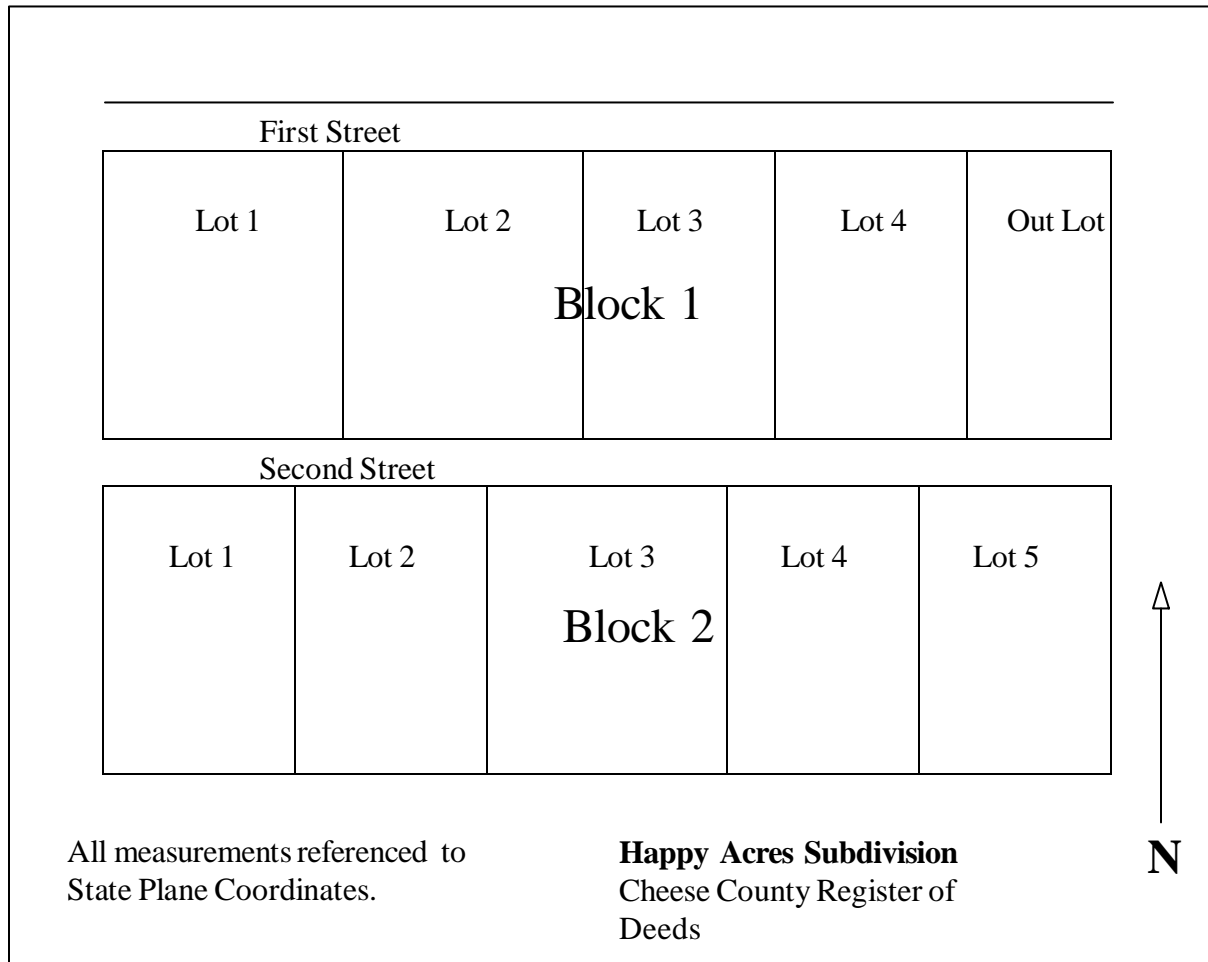

Sample description could be: Lot 2 Block 2 Happy Acres Subdivision Cheese County.

**Descriptions by Reference** - Reference to a recorded map or plat. These are common "area descriptions". The map or plat contains the linear measurements necessary to describe the areas.

Problems include:

11. Sometimes these descriptions are made based on combinations of references such as lots 1 and 2 of a block and plat.
12. Plats can be overlapping.
13. It is possible that the measurements within a plat or map may not close into polygons
14. The external boundaries of adjoining plats and maps may not match exactly.

## Sectionalized Descriptions

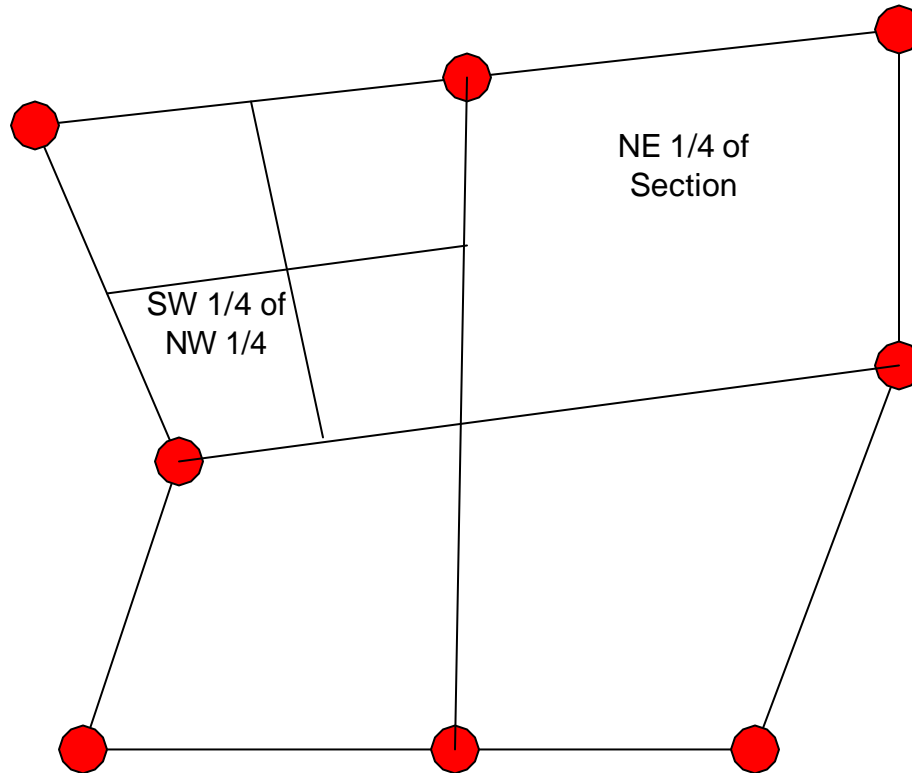

Sample descriptions are portions of sections described as quarters. The divisions are obtained through successive division of halving and quartering based on the rules of division present at the time of the section's first division.

**Sectionalized Descriptions** - Referenced to a division of the Public Land Survey System (PLSS). The rules and order of division are prescribed from sets of survey instructions, state laws, and possession evidence.

Problems include:

1. The rules of the division are established at the time of first division
2. Placed monuments control successive divisions
3. Misunderstanding of the use and division of sections

# Interpretation of Real Property Descriptions

---

## Description by Calls

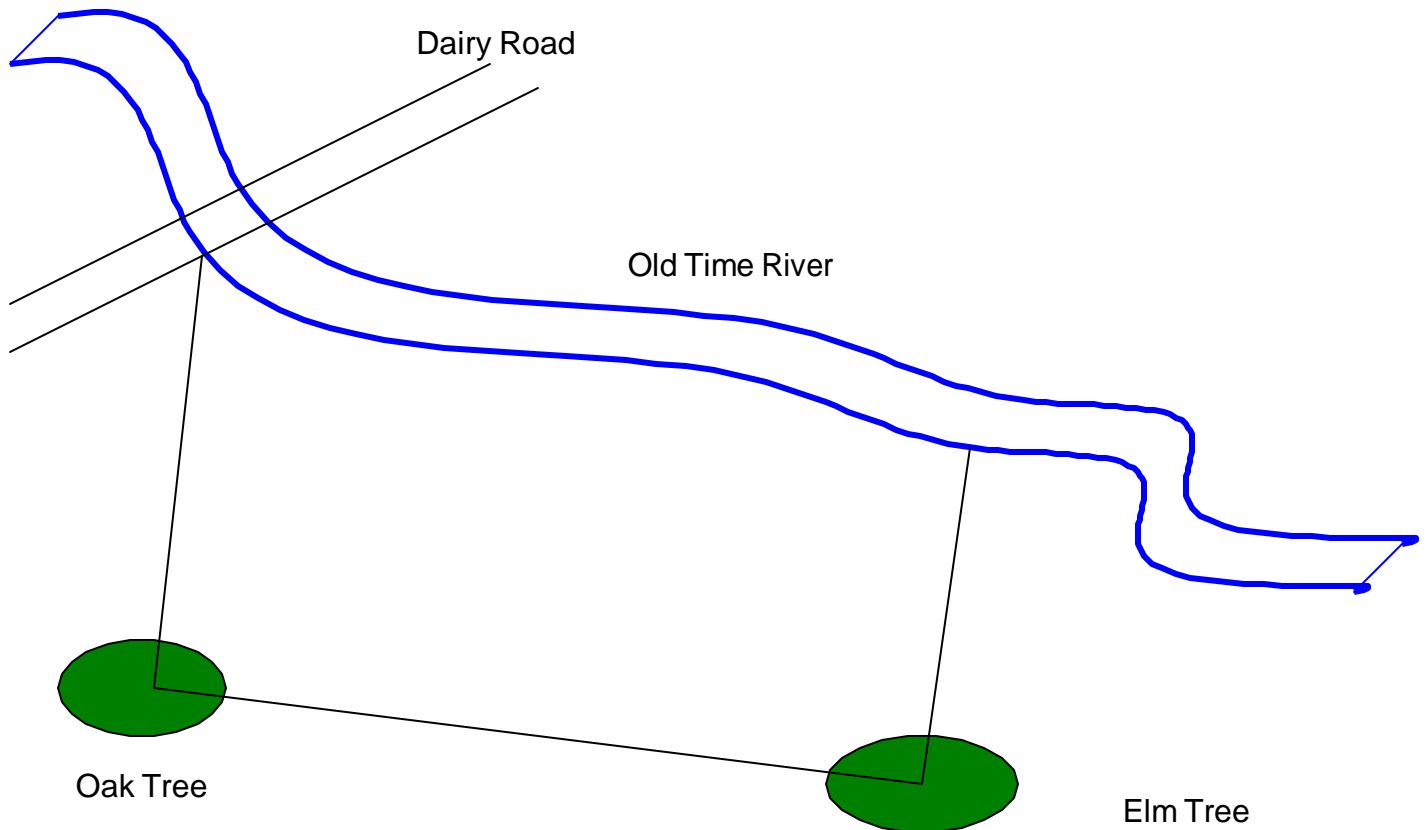

Beginning at the center of old time river where it crosses dairy road, thence southerly to an oak tree, thence easterly to an elm tree, thence northerly to the center of Old Time River, thence along the center or Old Time River to the point of beginning.

**Descriptions by Call** - Description by reference to physical objects. These are sometimes called deed calls or running out the calls.

Problems with Descriptions by Call:

1. Locating the objects can create uncertainty
2. The order of importance of conflicting information from the calls can create uncertainty or ambiguity, for example, if a call mentions a river and a tree as the same point and the two objects are in different places, then the correct location has to be determined

## Description by Division Line

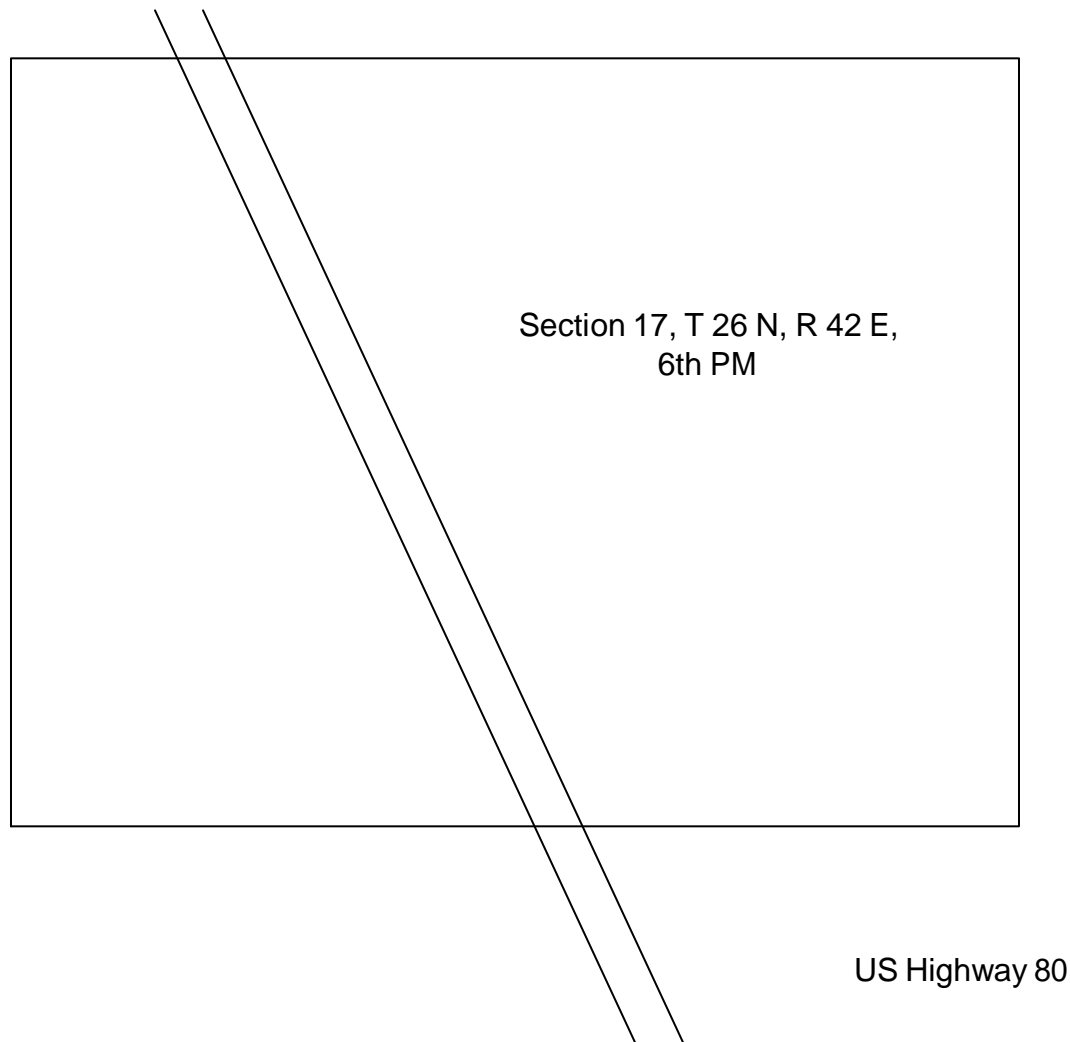

Sample description: all the lands laying west of highway 80, Section 17, T 26 N, R 42 E, 6th PM

**Description by Division Line** - This is a division of an existing or previously defined area, such as a lot, by dividing by a described line. This type of description always creates a remainder or other area that must be described as well. The line may be a measurement, such as metes, or a natural feature, such as a river, or other feature. This is a combination description because an area must be identified and then divided.

Problems with Description by Division Line:

1. Locating the division lines can be difficult, see description by calls
2. This can create uncertainty if the description of the division does adequately account for the entire area.

## Description by Distance

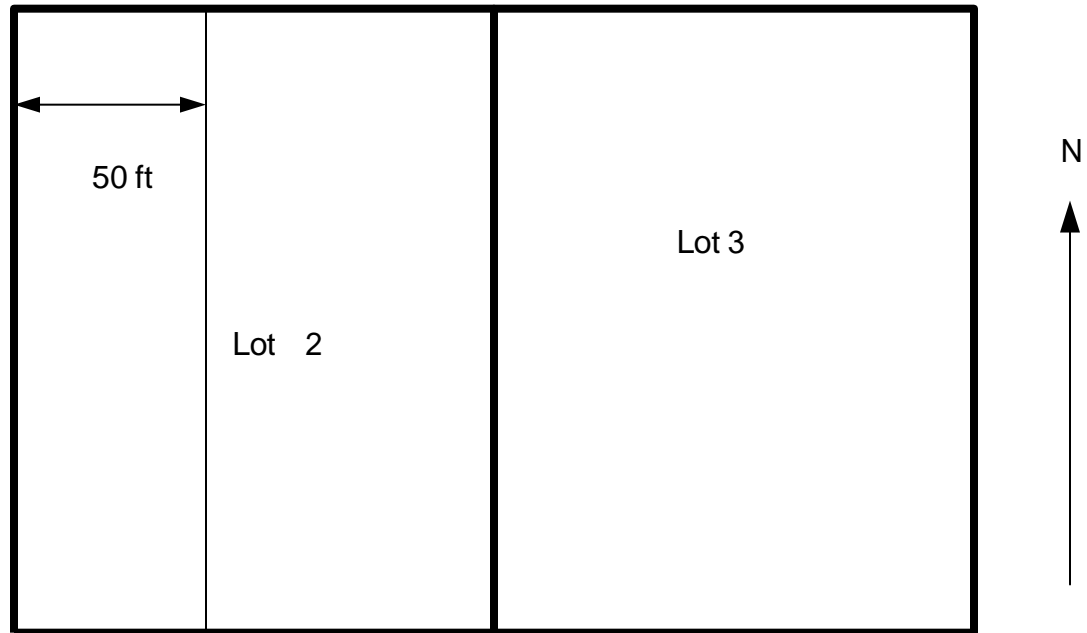

The westerly 50 feet of lot 2.

**Descriptions by Distance** - This is a division of an existing or previously defined area, such as a lot, by it dividing by a distance from a specified boundary line. This type of description always creates a remainder or other area that must be described as well. The distance has a reference boundary or side and a distance.

Problems with Descriptions by Distance:

1. Where to measure the distance from can be a problem of interpretation
2. The definition of parallel and perpendicular can be problematic for the same reason as above, determining where and with reference to which lines and features can be a problem



## Descriptions by Proportional Conveyances

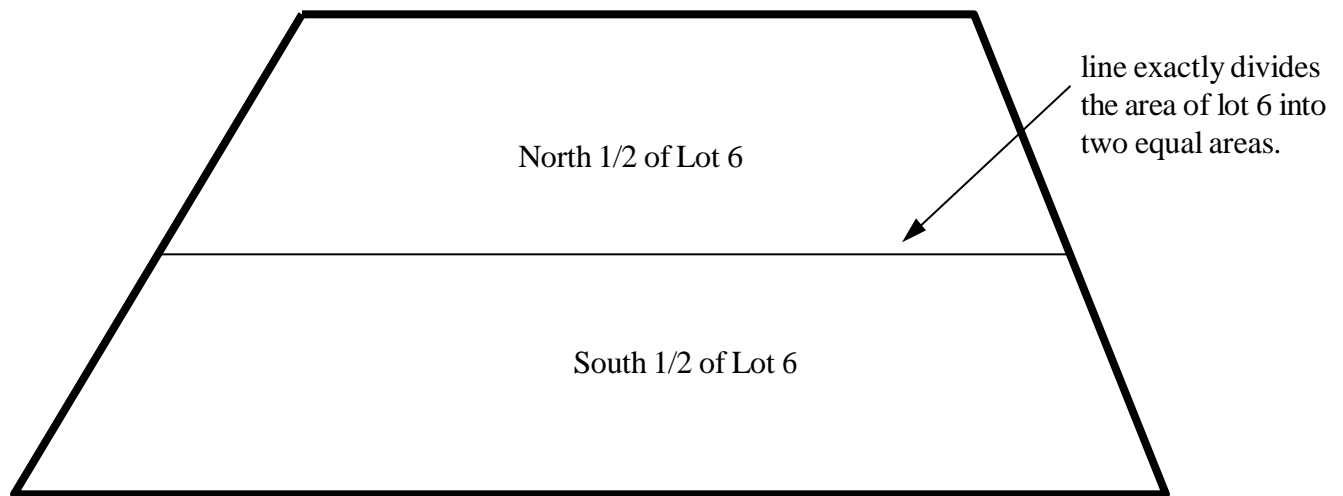

Example of a proportional description - North half of Lot 6.

**Descriptions by Proportional Conveyances** - This is a division of an existing or previously defined area, such as a lot, by specifying a proportion of area, such as half or third. If the amount of acres are specified, such as the North 30 acres, than it is a description by acreage and not a proportional description. This type of description always creates a remainder or other area that must be described as well.

Problems with Descriptions by Proportional Conveyances:

1. The direction of the dividing line may be indeterminate, implied or not given
2. There can be many ways to divide an area in half.
3. The geometric shape of the parcel being divided can complicate proportionate descriptions.

## Description by Exception

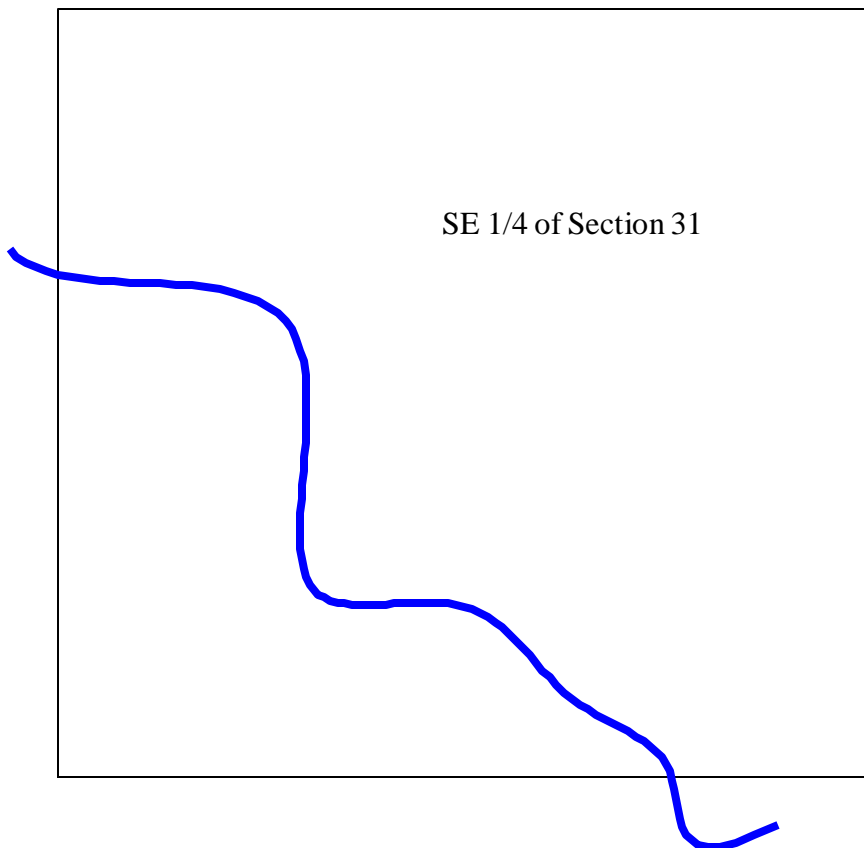

SE 1/4 of Section 31 except those lands lying south east of the river.

**Descriptions by Exception** - This is a division of an existing or previously defined area, and then excepting out an area. The exception can be any exempt area. This type of description always creates a remainder or other area that must be described as well. The exception can be described by any of the methods previously listed.

Problems with Descriptions by Exception are the same as those problems with the methods used to exclude the area.

## Description by Acreage

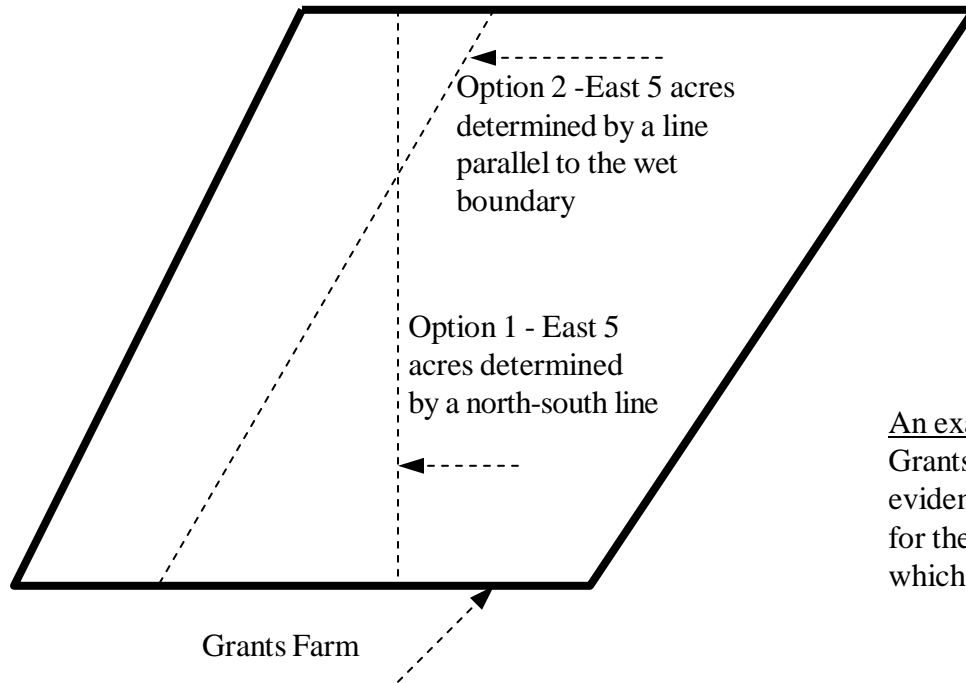

An example - East 5 acres of Grants Farm. The problems are evident in how is east defined for the purpose of establishing which east 5 acres.

**Descriptions by Acreage** - This is a division of an existing or previously defined area, such as a lot or a PLSS Section, by specifying an area amount. This is similar to the proportional area, except the amount of acreage being described is stated such as 10 acres. This type of description always creates a remainder or other area that must be described as well.

Problems with Descriptions by Acreage:

1. The direction and placement of division lines may be uncertain and subject to interpretation.
2. The remainder description can be problematic.

# Interpretation of Real Property Descriptions

---

## **Ambiguous Descriptions**

Ambiguous Descriptions - These are descriptions of areas or extents of land that can not be solved without significant research into the intent of the parties participating in the description and subsequent conveyance. These are sometimes called "of descriptions" but can take other forms as well. For example 50 feet of lot 2 may be indeterminate and may not be able to be placed without additional information.

Another example is the East 350 feet of lot 3 except the south 150 feet. Some of these appear to be descriptions by distance, but depending on the configuration of the parcel or area being dividing the of in the description is a key to identifying a legal description that might be problematic.

# Interpretation of Real Property Descriptions

## Example of Adjoiner Description

10-23-78 Blanche G. Brown, 1315 Crystal Lake Dr., Orlando, Fla 32806

#21

27-4-38

THIS DEED, Made this 10th day of October, 1978, by and between John M. Dulaney, single; Pemberton L. Dulaney, single; Margaret D. Gorby and Harry V. Gorby, her husband; Phoebe J. Palmer, widow, parties of the first part, and Blanche G. Brown, party of the second part.

Deed Book 292  
Page 215

WITNESSETH: That for and in consideration of the sum of Ten (\$10.00) Dollars, and other good and valuable considerations, the receipt of all of which is hereby acknowledged, said parties of the first part do grant and convey unto said party of the second part, with covenant of General Warranty, the following described property situate on the waters of Rush Run of Little Fishing Creek in Wetzel County, West Virginia, bounded and described as follows:

BEGINNING at a stone in John M. Dulaney's line; thence with a line of the heirs of C. Rush North 115 poles to a stake; thence N 66 W 12-4/5 poles to a stone; thence S 2 1/2 W 29 poles to a chestnut corner to A. J. Postlethwait; thence with said Postlethwait S 44° W 87 poles to a stone; thence S 35° E 14 poles to a stone in said John M. Dulaney's line; thence with the same S 76 1/2 E 70 poles to the beginning, containing 28 1/2 acres as surveyed by B. A. Pyles, October 31, 1893.

Being the same property conveyed by J. L. Dulaney, a widower, unto Pearl Dulaney, by deed dated the \_\_\_ day of \_\_\_\_\_, 19\_\_\_, and recorded in the office of the Clerk of the County Court of Wetzel County, West Virginia, in Deed Book no. \_\_\_\_\_, page \_\_\_\_\_. The said Pearl Dulaney died intestate, leaving surviving her Phoebe J. Palmer, Blanche G. Brown, John M. Dulaney, Pemberton L. Dulaney and Margaret M. Gorby, all of her children and heirs at law.

LEMON & LEMON  
Attorneys at Law  
178 Main Street

# Interpretation of Real Property Descriptions

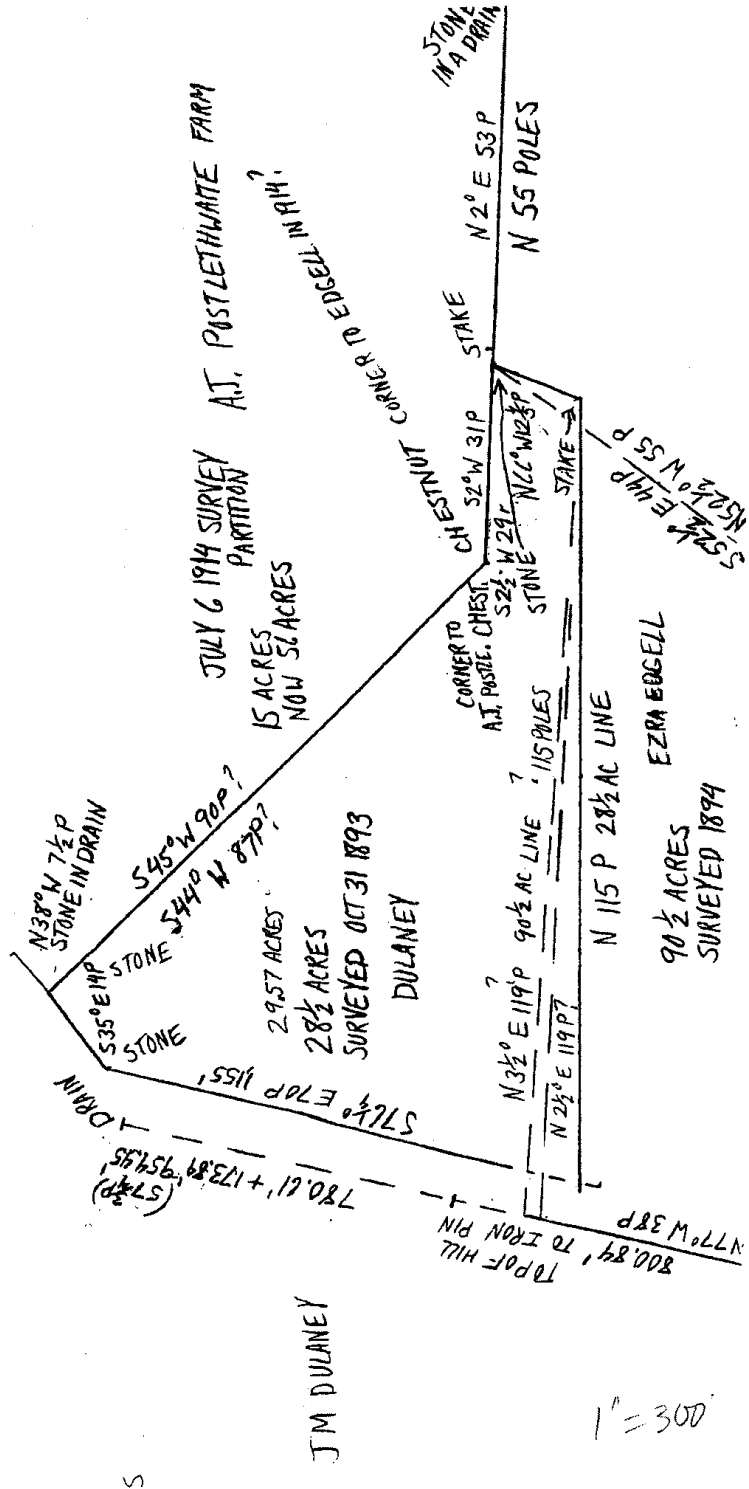

# Interpretation of Real Property Descriptions

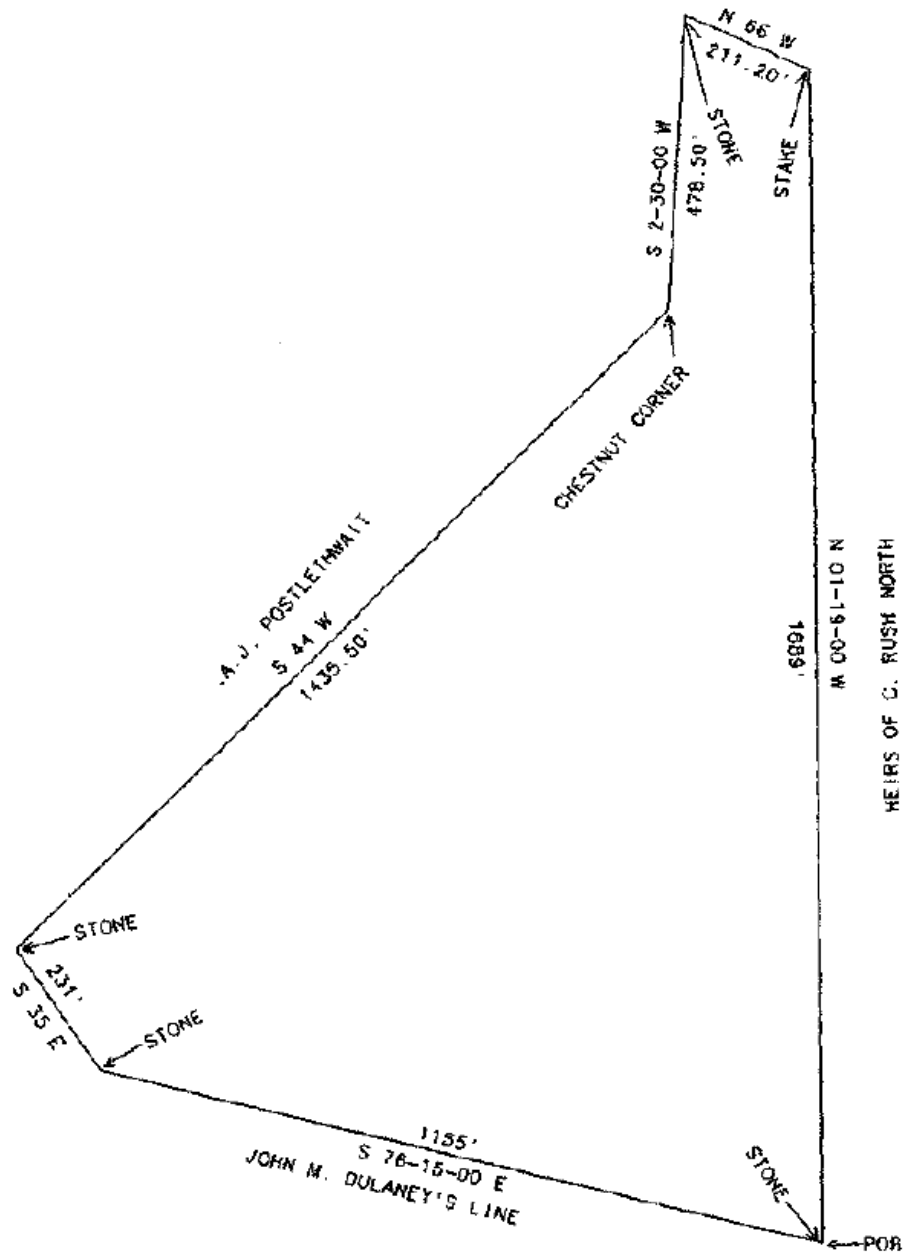





## Interpretation of Real Property Descriptions

---

This page intentionally left blank

This page intentionally left blank

# Interpretation of Real Property Descriptions

## Right Triangles

### Pythagorean Theorem

$$a^2 + b^2 = c^2$$

$$c^2 - a^2 = b^2$$

$$c^2 - b^2 = a^2$$

Solve for hyp:  $c = \sqrt{a^2 + b^2}$

Solve for leg:  $a = \sqrt{c^2 - b^2}$



### Sine

Sine = opposite side ÷ hypotenuse

### sine functions:

sine of an angle = opposite side ÷ hypotenuse

opposite side = hypotenuse × sine of an angle

hypotenuse = opposite ÷ sine of opp. angle



### Cosine

Cosine = adjacent side ÷ hypotenuse

### cosine functions:

cosine of an angle = adjacent side ÷ hypotenuse

adj. side = hypotenuse × cosine of adj. angle

hypotenuse = adj. side ÷ cosine of adj. angle



### Tangent

Tangent = opposite side ÷ adjacent side

### tangent functions:

tangent of an angle = opposite side ÷ adj. side

opposite side = adj. side × tangent of an angle

adj. side = opposite side ÷ tangent of adj. angle

## Coordinate System

Bearing formula:

$$(x_1 - x_2) \div (y_1 - y_2) = \tan \theta$$

Distance formula:

$$(x_1 - x_2)^2 + (y_1 - y_2)^2 = d^2$$

SinAZ x Distance = Chg in X

CosAZ x Distance = Chg in Y

## Law of Sines

$$\frac{a}{\sin A} = \frac{b}{\sin B} = \frac{c}{\sin C}$$

$$a = b \times \frac{\sin A}{\sin B} \quad a = c \times \frac{\sin A}{\sin C}$$

$$b = a \times \frac{\sin B}{\sin A} \quad b = c \times \frac{\sin B}{\sin C}$$

$$c = a \times \frac{\sin C}{\sin A} \quad c = b \times \frac{\sin C}{\sin B}$$

$$\sin A = \frac{a \times \sin B}{b} \quad \sin A = \frac{a \times \sin C}{c}$$

$$\sin B = \frac{b \times \sin A}{a} \quad \sin B = \frac{b \times \sin C}{c}$$

$$\sin C = \frac{c \times \sin A}{a} \quad \sin C = \frac{c \times \sin B}{b}$$

## Law of Cosines

$$c^2 = a^2 + b^2 - (2 ab \cos C)$$

$$b^2 = a^2 + c^2 - (2 ac \cos B)$$

$$a^2 = b^2 + c^2 - (2 bc \cos A)$$

$$\cos A = \frac{b^2 + c^2 - a^2}{2 bc}$$

$$\cos B = \frac{a^2 + c^2 - b^2}{2 ac}$$

$$\cos C = \frac{a^2 + b^2 - c^2}{2 ab}$$

## Areas

Trapezoid:

$$\text{Area} = \frac{1}{2} (\text{base}_1 + \text{base}_2) \times \text{height}$$

Triangle: Area =  $\frac{1}{2} (b \times h)$

Oblique Triangle: Area =  $\frac{1}{2} ab \times \sin C$

## Curves

### Radius

Highway curve

Radius = constant degree of curve ÷ degree of curve (Dc)

$$R = \frac{5729.58}{Dc} \quad R = \frac{\text{arc} \times 5729.58}{\Delta + 100}$$

$$R = \frac{\text{tangent length}}{\tan (\frac{1}{2} \Delta)} = \frac{180 \times \text{ArcL}}{\pi \times \Delta}$$

### Degree of Curve

$$Dc = \frac{5729.58}{R} (\text{Hwy}) \quad Dc = \frac{5729.65}{R} (\text{RR})$$

### Arc

$$\text{Arc} = \frac{100 \times \Delta}{Dc}$$

$$\text{Arc} = 100 \times (\Delta \div Dc)$$

### Chord

$$\text{chord} = 2R \times (\sin \frac{1}{2} \Delta)$$

### Delta or Central Angle Δ

$$\Delta = \frac{\text{ArcL} \times 5729.58}{R}$$

### Tangent Length

$$\text{tangent} = R \times (\tan \frac{1}{2} \Delta)$$

### Deflection Angle

$$\text{Deflection angle} = \frac{1}{2} \Delta$$

### Sector Area

$$\text{Sector area} = (\pi R^2) \times (\Delta \div 360)$$

### Segment Area

$$\text{Segment area} = \text{sector area} - \frac{R^2 \times \sin \Delta}{2}$$

### Fillet

$$\text{Fillet} = R \times T - (\pi R^2) \times (\Delta \div 360)$$

$$\text{Fillet} = R \times T - \text{sector}$$

### PC Station

$$\text{PC Station} = \text{PI station} - \text{tangent length}$$

### PT Station =

$$\text{PT Station} = \text{PC station} + \text{arc length}$$

# Interpretation of Real Property Descriptions

---

.....