

Installation Standard for Type AC & Type MC Armored Cables



National Armored Cable
Manufacturers Association

- Cable Selection
- Installation Procedures
- NEC & UL References



Installation Standard for Type AC & Type MC Armored Cables



National Armored Cable
Manufacturers Association
www.nacmaonline.com

- Cable Selection
- Installation Procedures
- NEC & UL References

Revision History	
NECA 120-2006	07-2006
NECA 120-2012	03-2013

NOTICE OF COPYRIGHT

Copyright © 2013 by the National Armored Cable Manufacturers Association (NACMA).

ALL RIGHTS RESERVED. No part of the document covered by the copyright hereon may be reproduced in any form or by any means—graphic, electronic, or mechanical, including photocopying, recording, taping, Web distribution or information storage or retrieval systems—without written permission of NACMA.

For permission to use material from this document contact:

National Armored Cable Manufacturers Association
106 Village Center Drive
Freehold, NJ 07728
(732) 866-0704
www.nacmaonline.com

NOTICE TO THE READER

Publisher does not warrant or guarantee any of the products described herein or perform any independent analysis in connection with any of the product information contained herein. Publisher does not assume, expressly disclaims, any obligation to obtain and include information other than that provided to it by the manufacturer.

Use of information in this document is voluntary and the reader is expressly warned to consider and adopt all safety precautions that might be indicated by the activities herein and to avoid all potential hazards. By following the instructions contained herein, the reader willingly assumes all risks in connection with such instructions.

The publisher makes no representation or warranties of any kind, including but not limited to the warranties of fitness for a particular purpose or merchantability, nor are any such representations implied with respect to the material set forth herein, and the publisher takes no responsibility with respect to such material. The publisher shall not be liable for any special, consequential, or exemplary damages resulting, in whole or part, from the reader's use of, or reliance upon, this material.

This publication is intended to comply with the edition of the National Electrical Code (NEC) in effect at the time of publication. This publication may, in some instances, go beyond the minimum safety requirements of the NEC. It is the responsibility of users of this publication to comply with state and local electrical codes when installing electrical products and systems. Pages 1 through 30 of this document were jointly copyrighted by NACMA and the National Electrical Contractors Association as Standard for Installing Armored Cable (AC) and Metal-Clad Cable (MC) NECA/NACMA 120-2013.

Table of Contents

- Foreword v**
- 1. Scope 1**
 - 1.1 Regulatory and Other Requirements 1
- 2. Glossary 2**
- 3. Identification of Cables 3**
 - 3.1 Identification 3
- 4. Armored Cable (Type AC) 5**
 - 4.1 Description 5
 - 4.2 Equipment Grounding 5
 - 4.3 Uses Permitted, General 6
 - 4.4 Uses Not Permitted 7
 - 4.5 Connectors 7
- 5. Metal-Clad Cables (Type MC) 9**
 - 5.1 Description 9
 - 5.2 Conductors 9
 - 5.3 Special MC Cable Configurations 9
 - 5.4 Equipment Grounding 10
 - 5.5 Uses Permitted 11
 - 5.6 Uses Not Permitted 13
 - 5.7 Connectors 13
- 6. General Installation Procedures 16**
 - 6.1 General Installation Procedures for Type AC and MC Cables 16
 - 6.2 Installation of Homeruns 18
 - 6.3 Cutting AC and MC Cables 20
 - 6.4 Position of Cable in Connector 20
 - 6.5 Overcurrent Protection and Derating 21
 - 6.6 Fishing Cables 22
 - 6.7 Installing Cables Through Fire-Rated Walls, Floors or Ceilings 23
- 7. AC Cables—Specific Installation Procedures 24**
 - 7.1 Boxes and Fittings 24
 - 7.2 Isolated Equipment Grounding 24
 - 7.3 Health Care Facilities 24

8.	MC Cables—Specific Installation Procedures	26
8.1	Boxes and Fittings	26
8.2	Isolated Equipment Grounding	26
8.3	Health Care Facilities	26
8.4	Terminating Type MC Cable Containing Bare Aluminum Bonding/Grounding Conductor.....	28
9.	Type MC Cables in Hazardous (Classified) Locations	29
9.1	Class I Locations.....	29
9.2	Class II Locations	29
9.3	Seals in Hazardous (Classified) Locations.....	29
	Annex A: Reference Standards.....	31

(This foreword is not a part of the standard)

Foreword

National Electrical Installation Standards™ are designed to improve communication among specifiers, purchasers, and suppliers of electrical construction services. They define a minimum baseline of quality and workmanship for installing electrical products and systems. *NEIS™* are intended to be referenced in contract documents for electrical construction projects. The following language is recommended:

Type AC and MC Cables shall be installed in accordance with NECA/NACMA 120, *Standard for Installing Armored Cable (AC) and Metal-Clad Cable (MC)* (ANSI).

Use of *NEIS™* is voluntary, and the National Electrical Contractors Association assumes no obligation or liability to users of this publication. Existence of a standard shall not preclude any member or nonmember of either organization from specifying or using alternate construction methods permitted by applicable regulations.

This publication is intended to comply with the edition of the National Electrical Code® (NEC) in effect at the time of publication. Because they are quality standards, *NEIS* may in some instances go beyond the minimum safety requirements of the NEC. It is the responsibility of users of this publication to comply with state and local electrical codes when installing electrical products and systems.

Suggestions for revisions and improvements to this standard are welcome. They should be addressed to:

NECA Codes and Standard
3 Bethesda Metro Center, Suite 1100
Bethesda, MD 20814
(301) 215-4521
(301) 215-4500 Fax
www.neca-neis.org
neis@necanet.org

To purchase *National Electrical Installation Standards™*, contact the NECA Order Desk at (301) 215-4504 tel, (301) 215-4500 fax, or orderdesk@necanet.org. *NEIS* are also available in .PDF download format at www.neca-neis.org/catalog.

Copyright © 2013, National Electrical Contractors Association. All rights reserved. Unauthorized reproduction prohibited.

National Electrical Installation Standards and *NEIS* are trademarks of the National Electrical Contractors Association. National Electrical Code and NEC are registered trademarks of the National Fire Protection Association, Quincy, Massachusetts.

Photos courtesy of NACMA, except where noted.

<This page intentionally left blank>

1. Scope

This standard covers the installation of Type AC and Type MC cables, which are used for electrical wiring for residential, commercial and industrial occupancies. It also includes information on fittings and other accessories necessary for a quality installation of these cable systems.

This standard is intended to enhance electrical safety by:

1. Ensuring that the proper cable is selected for the installation.
2. Describing proper installation methods for Type AC and MC cables.
3. Aiding installers in meeting the “neat and workman like” requirements of the NEC.
4. Creating an installation that will protect the wire conductors from mechanical abuse.

1.1 Regulatory and Other Requirements

a) All information in this publication is intended to conform to the National Electrical Code (ANSI/NFPA Standard 70). Installers should always follow

the NEC, applicable state and local codes, and manufacturers’ instructions when installing electrical products and systems.

b) Only qualified persons as defined in the NEC familiar with the construction and installation of Type AC and Type MC cables should perform the technical work described in this publication. Administrative functions and other tasks can be performed under the supervision of a qualified person. All work should be performed in accordance with NFPA 70E, *Standard for Electrical Safety in the Workplace*.

c) General requirements for installing electrical products and systems are described in NECA 1-2010, *Standard Practices for Good Workmanship in Electrical Construction* (ANSI). Other *National Electrical Installations Standards* provide guidance for installing particular types of electrical products and systems. A complete list of *NEIS* is provided in Annex A.

2. Glossary

Fire-stopping

Using approved materials (generally detailed by building codes or specifications) which fill the opening around the cable(s) to prevent the spread of fire and smoke and to assure the fire rating of the wall, floor, or ceiling being penetrated is not reduced.

Fire-related Assemblies

Construction materials assembled together, then tested and rated for their ability to inhibit the spread of fire for a specified period of time under specific test conditions. The rating is expressed in hours, e.g. 1 hour, 2 hour, etc. Information can be found in various product testing laboratory listing directories.

Fishing

The installation of cable in closed or partially closed construction by pushing or pulling it from one point of access to another.

Homerun

The installation of cable(s), conduit(s) or tubing(s) between the panelboard and the first distribution point such as a junction or pull box where branch circuit cables originate.

Through-Penetration Fire Stop Systems

A listed assemblage of specific materials or products that are designed, tested and fire-resistance rated in accordance with ASTM E814 to resist, for a prescribed period of time, the spread of fire through penetrations in fire-rated assemblies.

Note: The NEC provides definitions of Armored Cable, Type AC and Metal-Clad Cable, Type MC.

3. Identification of Cables

3.1 Identification

Type MC cable of the interlocked-armor type and Type AC cable may look similar on their exterior. It is important that the proper cable be selected for installations where specific construction features or performance requirements are desired or are required in the NEC. Specific uses permitted and not permitted are identified in the following sections of this standard. Consult **Table 1** (*next page*) for assistance in identifying cables.

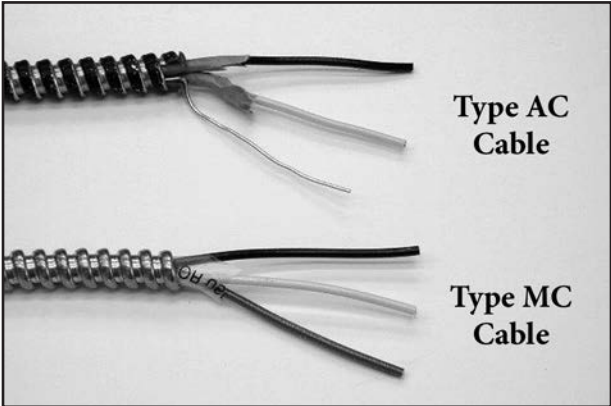

Figure 3.1, AC and MC Cable

Table 1 Identification of Type AC and MC Cables

	Type AC Cable	Interlocked Armor Type MC Cable	Interlocked Armor Type MC Cable with Armor/Bond (MCI-A) ¹
Number of Circuit Conductors	Limited to no more than 4 conductors plus an equipment grounding conductor.	No limit on number of conductors.	No limit on number of conductors.
Size of Conductors	14 AWG to 1 AWG	18 AWG – 2000 kcmil	14 AWG –6 AWG
Equipment Grounding Path	Contains a minimum 16 AWG bond wire in constant contact with the metal armor. The bond wire and armor together are used as an equipment grounding conductor.	No bonding wire. The armor is not itself an equipment ground. The internal equipment grounding conductor in combination with the armor is the equipment ground.	Contains a full size aluminum grounding/bonding conductor in constant contact with the metal armor. The bond wire and armor together are used as an equipment grounding conductor.
Cable Construction	Individual thermoplastic insulated conductors are wrapped in a moisture resistant, fire retardant paper. Individual conductors with thermoset insulation do not require a paper wrap, the wrap must be applied to the entire assembly.	A protective covering over the individual insulated or jacketed conductors may be provided or the conductor assembly may have an overall nonmetallic wrap under the armor	A protective covering over the individual insulated or jacketed conductors may be provided or the conductor assembly may have an overall nonmetallic wrap under the armor

¹The abbreviation (MCI-A) is used for the sake of brevity and is not specifically noted in the NEC nor UL 1569.

4. Armored Cable (Type AC)

4.1 Description

Type AC cable is a factory assembly of insulated conductors protected in an overall flexible interlocked metallic armor (sheath). The metallic sheath may be of aluminum or steel material. Armored cable having an aluminum sheath is suitable for use in alternating current circuits only.

Type AC cable is permitted to have from two to four conductors in sizes 14 through 1 AWG copper with or without an equipment grounding conductor. All conductors with thermoplastic insulation have an individual moisture-resistant fiber wrap and are cabled together in the manufacturing process.

Typical branch circuit Type AC cables have copper conductors with THHN insulation. Type AC cable is available with conductors in three different insulation ratings:

ACTH—conductors rated 75°C with thermoplastic insulation.

ACTHH—conductors rated 90°C with thermoplastic insulation. (This is the typical cable construction.)

ACHH—conductors rated 90°C with thermosetting insulation.

4.2 Equipment Grounding

a) *Bonding Strip*. Type AC cable has a bare 16 AWG aluminum bonding strip installed between the conductors and the outer armor that is in intimate contact with the armor for the full length of the cable. The outer armor of the cable in conjunction with this bonding strip is acceptable as an equipment grounding conductor.

b) *Insulated Grounding Conductor*. Some Type AC cables also contain, in addition to the circuit conductors, an insulated equipment grounding conductor. AC cables of this type are permitted for installation in patient care areas of health care facilities and for isolated equipment grounding conductor installations.

Table 4.3 Uses Permitted, General

Where not subject to physical damage, Type AC cable is permitted to be installed:	Type of AC cable	
	Without insulated equipment grounding conductor	With insulated equipment grounding conductor
In both exposed and concealed work	Yes	Yes
In cable trays (no identification for use required)	Yes	Yes
In dry locations	Yes	Yes
Embedded in plaster finish on brick or other masonry, except in damp or wet locations	Yes	Yes
Run or fished in the air voids of masonry block or tile walls where such walls are not exposed or subject to excessive moisture or dampness	Yes	Yes
For feeders	Yes	Yes
For branch circuits	Yes	Yes
Other spaces used for environmental air (plenums)	Yes	Yes

4.3.1 Uses Permitted, Special Occupancies

This Table is not all-inclusive. Additional uses of Type AC cable may be permitted in other NEC Articles. Consult those Articles for any conditions of usage that are required.

Where not subject to physical damage, Type AC cable is permitted to be installed:	Type of AC cable	
	Without insulated equipment grounding conductor	With insulated equipment grounding conductor
In Class I, Division 2 areas for nonincendive field wiring	Yes	Yes
In Class II, Division 2 areas for nonincendive field wiring	Yes	Yes
For intrinsically safe systems	Yes	Yes
For “normal system” in patient care areas of health care facilities including; hospitals, nursing homes, limited care facilities, clinics, medical and dental offices, and ambulatory care facilities, whether permanent or movable	No	Yes
In other than patient care areas of hospitals, for mechanical protection of emergency system (critical and life-safety branches) where fished	Yes	Yes

Where not subject to physical damage, Type AC cable is permitted to be installed:	Type of AC cable	
	Without insulated equipment grounding conductor	With insulated equipment grounding conductor
In patient care areas of hospitals, for mechanical protection of emergency system (critical and life-safety branches) where fished	No	Yes
In patient care areas of nursing homes, limited care facilities, clinics, medical and dental offices, and ambulatory care facilities hospitals, for wiring of life safety and critical branches	No	Yes
Areas of nursing homes and limited care facilities wired in accordance with Chapters 1 through 4 of the NEC where the areas are used exclusively as patient sleeping rooms	Yes	Yes
In assembly occupancies, fire-rated construction	Yes	Yes
In assembly occupancies, non fire-rated construction	Yes	Yes
For theaters, audience areas of motion picture and television studios, performance areas, and similar locations, fire-rated construction	No	Yes
For theaters, audience areas of motion picture and television studios, performance areas, and similar locations, non fire-rated construction	Yes	Yes
For motion picture and television studios and similar locations, permanent wiring of stage or set	No	Yes
For cranes and hoists (dry locations only)	No	Yes
For elevators, dumbwaiters, escalators, moving walks, wheelchair lifts and stairway chair lifts	Yes	Yes
For information technology equipment, under raised floors	Yes	Yes

4.4 Uses Not Permitted

Type AC cable is not permitted to be installed:

- As service-entrance conductors.
- Where subject to physical damage unless protected by conduit or tubing
- In damp or wet locations
- In air voids of masonry block walls where the walls are exposed to or are subject to excessive moisture or dampness

- Where exposed to corrosive conditions
- Embedded in plaster finish on brick or other masonry in damp or wet locations

4.5 Connectors

a) *AC cable connectors*. Fittings for connecting Type AC cable are required to be marked as suitable for such use. The identification is either on the smallest container in which the product is packaged or is on the connector itself. Select the appropriate size of

cable connector for the trade size of the cable. Some connectors are suitable for connecting two cables. The reference in the UL White Book for Type AC cable connectors is (AWSX).

b) *AC cable set-screw connectors.* As provided in the UL White Book (AWEZ) for Armored Cable, connectors of the set-screw type are only permitted to be used with cables having steel armor. They are not acceptable on cables with aluminum armor.

c) *Other connectors.* Connectors for Type MC cable and power and control tray cable are also suitable for use with Type AC cable when specifically indicated on the connector or the shipping carton.

d) *Insulating bushings.* Connectors or clamps that connect Type AC cable to boxes or cabinets are designed so the required insulating bushing is visible for inspection after the cable is connected. The insulating bushing is often referred to in trade jargon as a “red head.”

e) *Grounding.* All listed connectors for Type AC cable are suitable for grounding since the armor of Type AC cable serves as the equipment grounding conductor. Remove paint or other insulating material between the enclosure and the connector to ensure a proper grounding connection.

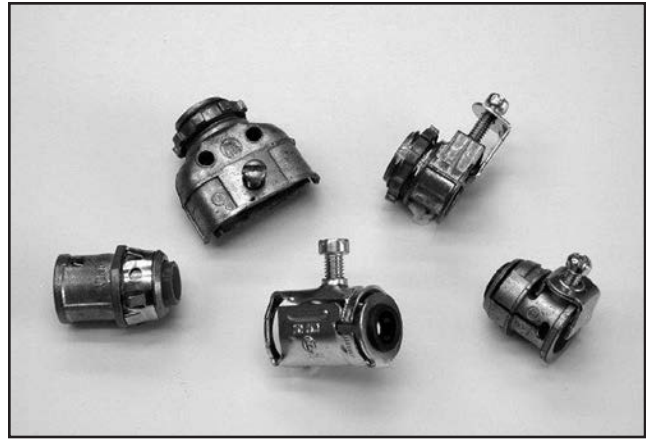

Figure 4.5—Connectors for Type AC and Type MC cables.

5. Metal-Clad Cables (Type MC)

5.1 Description

Type MC cable is a factory assembly of one or more insulated current-carrying conductors and one or more equipment grounding conductors (if required) in an overall metallic sheath. MC cable is manufactured with three different types of armor in the following configurations:

1. Interlocking metal-tape (steel or aluminum) – (MCI)
2. Interlocking metal-tape (steel or aluminum) Armor ground – (MCI-A)
3. Smooth metal tube (aluminum only) – (MCS)
4. Corrugated metal tube (copper or aluminum) – (MCC)

Type MC cable consists of one or more current-carrying conductors, one or more equipment grounding conductors if required, and in some cases optical fibers. MC cables containing optical fibers are designated Type MC-OF and are considered composite cables in accordance with NEC Article 770.

5.2 Conductors

a) *Branch circuits, Feeders, and Services.* Type MC cable is permitted to contain conductors from 18 AWG through 2000 kcmil for copper and 12 AWG through 2000 kcmil for aluminum. Typical branch circuit Type MC cables have copper conductors with THHN, THHN/THWN/THWN-2 or XHHW/XHHW-2 insulation and are suitable for circuits up to 600 volts. Typical feeder and service size Type MC cables have aluminum or copper conductors with THHN/THWN-2 or XHHW/XHHW-2 insulation and are suitable for circuits up to 600 volts. Higher voltage constructions and other insulation types may be available.

b) *Medium voltage.* Type MV cables are available with conductor insulations rated from 2,400 to 35,000 volts and may be marked for use as Type MC cables.

c) *Fire alarm.* Type MC cables intended for fire alarm/control applications have TFN, TFFN, THHN or other suitable insulation.

5.3 Special MC Cable Configurations

In addition to “standard” configurations used for services, feeders and branch circuits, MC cables are manufactured for the following specific applications:

Fire Alarm. This Type MC cable is manufactured with either steel or aluminum armor and contains 18 through 10 AWG copper conductors with TFN, TFFN, or THHN insulation. Other appropriate conductor insulations may be used. In addition, the cable contains a bare or insulated equipment grounding conductor. Install according to NEC Article 760 or NFPA 72 *National Fire Alarm and Signaling Code*.

Composite Cable. This Type MC-OF cable construction contains electrical power and/or control conductors with one or more optical fiber elements. It is installed in accordance with the NEC Article for the type of power or control conductors involved. Composite Type MC cable is available with a PVC jacket and is suitable for direct burial in earth or in concrete. Composite Type MC cable with electric power conductors is permitted to have a bare or insulated equipment grounding conductor.

Oversize neutral conductors. This Type MC cable has standard size circuit conductors and one or more neutral conductors that are larger than the circuit conductors. This cable is often used to safely

handle excessive neutral harmonic currents caused by nonlinear loads. Nonlinear loads are typically produced in branch circuit and feeder wiring for computers, programmable controllers, electronic/electric discharge lighting, computers and other office machines and other electronic equipment that introduce additive harmonic currents from nonlinear switching loads. This MC cable type also has a bare or insulated equipment grounding conductor sized for the typical overcurrent protection permitted by Code for the ungrounded conductors.

Multiple individual neutral conductors. This Type MC cable has a color-coded neutral conductor for each ungrounded branch circuit conductor. Similar to the oversize-neutral-conductor cable, this cable is often used to prevent harmonic currents caused by nonlinear loads that are present in multiwire branch circuits. Since each ungrounded conductor has a paired grounded (neutral) conductor, simultaneous disconnecting is not required as is the case for multiwire branch circuits. The cable also has a bare or insulated equipment grounding conductor sized for the typical overcurrent protection permitted by Code for the ungrounded conductors. (Figure 5.3.1).

Homerun. This cable is available in various configurations with multiple sets of branch circuit conductors intended to be installed as multiwire branch circuits. The ungrounded (phase) and neutral conductors are color-coded in sets for identification purposes. If more than three conductors in the cable are considered as “current-carrying,” an adjustment

factor must be applied in accordance with NEC 310.15(B)(3)(a). If the conductor insulation is 90°C, apply the adjustment factor to the appropriate ampacity in the 90°C column of Table 310.15(B)(16). Use the 75°C column if the conductor insulation is rated 75°C. The cable also has an insulated equipment grounding conductor sized for the typical overcurrent protection permitted by Code for the ungrounded conductors.

PVC jacketed cable. A PVC jacket is extruded over the steel or aluminum armor. This construction is suitable for use in dry locations, and where so identified, in damp or wet locations and for direct earth burial. Cable that is identified for direct earth burial is also suitable for encasement in concrete without additional marking. This construction may also be identified as “sunlight resistant” and “oil resistant” and for use in cable trays. The cable also has an insulated or bare equipment grounding conductor sized for the typical overcurrent protection permitted by Code for the ungrounded conductors.

5.4 Equipment Grounding

5.4.1 Interlocking Metal Tape Sheath

The armor of Type MC Cable with an interlocking metal tape sheath (MCI) is not itself suitable as an equipment grounding conductor. The cable includes an equipment grounding conductor which is either bare or insulated. For branch-circuit sizes, the most



Figure 5.3.1—Multiple Neutral Conductors



Figure 5.3.2—PVC Jacketed Cable (courtesy AFC Cable Systems)

common type of equipment grounding conductor is insulated with an unstriped (solid) green color.

The armor of Type MC Cable with an interlocking metal tape sheath and a bare aluminum grounding/bonding conductor cabled with the insulated conductors (MCI-A) is suitable as an equipment grounding path.

a) *Sectioned.* Larger sizes of MC cable with interlocking metal tape sheath sometimes have the equipment grounding conductor “sectioned.” This means a large equipment grounding conductor is divided into several smaller conductors, all of the same AWG size. This permits the manufacturer to make the cable of a smaller diameter as the smaller conductors take the place of filler that would otherwise be needed. Unless permitted by the AHJ to be twisted together and terminated in a single connector, smaller equipment grounding conductors that are sectioned in this way must be connected individually to an equipment grounding terminal bar.

b) *Isolated ground MC cables.* MC cables with an additional equipment grounding conductor are often used for applications such as computer or cash register branch circuits. These cables are marked “IG” for “isolated ground.” Each additional equipment grounding conductor has green insulation with either a yellow stripe, or a surface marking, or both.

c) *Patient care areas.* The outer armor of the interlocked metal sheath Type MC cable (MCI) is not permitted as an equipment grounding conductor. As a result, this type of Type MC cable (MCI) is not permitted as the wiring method in

patient care areas of health care facilities. The armor of Type MC Cable with an interlocking metal tape sheath and a bare aluminum grounding/bonding conductor cabled with the insulated conductors (MCI-A) is suitable as an equipment path. As a result, this type of Type MC cable (MCI-A) is permitted as the wiring method for branch circuits on the normal power source in patient care areas of health care facilities.

5.4.2 Smooth or Corrugated Sheath

The armor of Type MC cables with smooth or corrugated sheaths, or a combination of the sheath and a supplemental bare or unstriped green insulated conductor, is suitable for use as an equipment grounding conductor.

a) *Bare equipment grounding conductor or green insulation without a stripe.* This Type MC cable type has a sheath that is not itself suitable as an equipment grounding conductor. Type MC cable of this construction is not permitted to be used in patient care areas of health care facilities. In addition, it is not suitable for use in isolated equipment ground circuits.

b) *Green insulated equipment grounding conductor with a yellow stripe.* This Type MC cable has a sheath that is suitable for use as an equipment grounding conductor. Cable with this construction is permitted in patient care areas of health care facilities or for isolated equipment grounding circuits.

Table 5.5 Uses Permitted

Where not subject to physical damage, Type MC cable is permitted to be installed as follows:	Comments
For services	Comply with Article 230
For feeders	Comply with Articles 215 or 225
For branch circuits	Comply with the applicable NEC article
For power, lighting, control and signal circuits	Comply with the applicable NEC article
Indoors and outdoors	Comply with all environmental conditions

Where not subject to physical damage, Type MC cable is permitted to be installed as follows:	Comments
Where exposed or concealed	Protect from physical damage where required
Directly buried where identified for such use	Cables with an overall outer PVC jacket marked for direct burial are suitable for direct burial and concrete encasement. Comply with 300.5 or 300.50 for minimum burial depth
In cable tray	Comply with Article 392
In any raceway	Comply with raceway fill in NEC Chapter 9, Table 1
As open runs of cable	Support properly (see Section 6.1)
As aerial cable on a messenger	Comply with Article 396. See below for wet locations
In hazardous (classified) locations	See below
Embedded in plaster finish on brick or other masonry	Dry locations only
In wet locations	Permitted if: <ul style="list-style-type: none"> a. the metallic covering is impervious to moisture, or b. a moisture-impervious jacket is provided under the metal covering, or c. the insulated conductors under the metallic covering are listed for use in wet locations (such as THWN) and a corrosion-resistant jacket is provided over the metallic covering
Single-conductor applications	Group all phase, neutral and equipment grounding conductors together. Sheath or armor is required to be nonferrous.
Ducts or plenums used for environmental air	Use cable having smooth or corrugated impervious metal sheath without an overall nonmetallic covering
Other spaces used for environmental air (plenum)	Use cable without an overall nonmetallic covering
For “normal system” in patient care areas of health care facilities including; hospitals, nursing homes, limited care facilities, clinics, medical and dental offices, and ambulatory care facilities, whether permanent or movable	The outer metal armor or sheath must be identified as an acceptable equipment grounding return path
In other than patient care areas of hospitals, for mechanical protection of emergency system (critical and life-safety branches) where fished	Any type of MC cable permitted
In patient care areas of hospitals, for mechanical protection of emergency system (critical and life-safety branches) where fished	The outer metal armor or sheath must be identified as an acceptable grounding return path
In non-patient care areas of health care facilities	Any type of MC cable permitted
Assembly occupancies, fire-rated construction	Any type of MC cable permitted
Assembly occupancies, non fire-rated construction	Any type of MC cable permitted

Where not subject to physical damage, Type MC cable is permitted to be installed as follows:	Comments
For theaters, audience areas of motion picture and television studios, performance areas, and similar locations, fire-rated construction	Any type of MC cable permitted
For theaters, audience areas of motion picture and television studios, performance areas, and similar locations, non fire-rated construction	Any type of MC cable permitted
For motion picture and television studios and similar locations, permanent wiring of stage or set	Any type of MC cable permitted
For cranes and hoists	Any type of MC cable permitted. See above for wet locations.
For elevators, dumbwaiters, escalators, moving walks, wheelchair lifts and stairway chair lifts	Any type of MC cable permitted
For information technology equipment, under raised floors	Any type of MC cable permitted
Fire-wall through-penetrations.	Suitable for 1, 2 or 3-hour fire-rated assemblies. Follow manufacturer’s installation instructions or UL Fire Resistance Directory design number parameters

Table 5.6 Uses Not Permitted

Type MC cable is not permitted to be installed:	Comments
Where exposed to corrosive fumes or vapors	Is permitted where the metallic sheath is suitable for the conditions or is protected by material suitable for the conditions (Such as cable with an overall PVC jacket)
Directly buried in earth	Is permitted where the overall jacketed cable is listed and marked for direct burial.
In concrete	Is permitted where the overall jacketed cable is listed and marked for direct burial. Cables so marked are also considered acceptable for encasement in concrete.
Where exposed to cinder fills, strong chlorides, caustic alkalis, or vapors of chlorine or of hydrochloric acids.	Is permitted where the metallic sheath is suitable for the conditions or is protected by material suitable for the conditions (Such as cable with an overall PVC jacket)

5.7 Connectors

5.7.1. Criterion for Selecting

Fittings for connecting Type MC cable are required to be listed and suitable for the purpose. The reference in the UL White Book for Type MC cable

connectors is (PJOX). Criterion for selecting proper fittings include:

- a) The range of cable diameters and the type of cable sheath (interlocking, smooth, corrugated, or polymeric jacket).

- b) The material of the sheath (aluminum, copper, steel, or polymeric jacket) for which they are suitable.
- c) “Concrete-tight” if suitable for use in poured concrete.
- d) “For Type MC cable” or similar wording if suitable for that use.
- e) “Dry locations” where the connectors are suitable for only that location.
- f) “Wet locations” where installed in a wet location.

5.7.2 Identification of Connector

The identification is either on the connector itself or the smallest container in which the product is packaged.

Table 5.7.2

Type of Metal-Clad Cable	Abbreviation
Metal-clad interlocking armor cable	MCI
Metal-clad interlocking armor ground cable	MCI-A
Metal-clad continuous smooth sheath armor cable	MCS
Metal-clad continuous corrugated sheath armor cable	MCC
Metal-clad continuous corrugated sheath armor cable, flat	FLAT

Connectors for Type MC cable, and for power and control tray cable, are also suitable for use with Type AC cable when specifically indicated on the connector or the shipping carton.

5.7.3 Connector Size

Select the appropriate size of cable connector for the dimensions of the cable. The size of cable the connector is designed to terminate may be marked on the shipping carton. The marked dimension or dimensional range of the connector is the diameter of the cable over the armor sheath but under any outer jacket that may be a part of the cable’s

construction. For some applications of jacketed Type MC cables, the diameter over the jacket must be considered for connector sizing. Connectors are available for connecting two cables in one knockout. Review the installation location to be certain there is adequate space for the fitting and that the set-screw can be tightened properly.

5.7.4 Suitable for Type of Cable or Location

Select the connector that is suitable for the type of cable or the location where the connector is being installed:

- a) *Set-screw connectors* are permitted to be used only on MC cables with steel armor and are not acceptable for cables with aluminum armor.
- b) *Aluminum connectors* are permitted for use only with corrugated aluminum, interlocked aluminum or smooth aluminum tube MC cables, unless marked otherwise on the carton. Aluminum connectors are not permitted to be used in concrete or cinder fill unless protected by asphaltic paint or equivalent corrosion protection.
- c) *Concrete-tight* connectors should be used to secure PVC-jacketed MC cable embedded in concrete to boxes or other enclosures where the connections are covered in concrete. Some connectors are suitable for use on jacketed Type MC cable only when taped. The packaging for these connectors will be marked “Concrete tight when taped when used with jacketed aluminum Type MC cable and jacketed steel Type MC cable.”
- d) *Wet-location* connectors must be used for cable connections in wet locations. Connectors are available for connection of cables to enclosures such as panelboards, pull boxes and wireways as well as with a union-type feature to facilitate connection to weatherproof threaded hubs.

5.7.5 Grounding

Listed connectors for use with metal-clad interlocking armor ground cable (MCI-A), corrugated aluminum or copper tube or smooth aluminum tube cable are suitable for grounding in

circuits over and under 250 volts since the outer armor of these types of Type MC cable serves as the equipment grounding conductor. Remove paint or other insulating material between the enclosure and the connector to ensure a proper grounding connection.

6. General Installation Procedures

6.1 General Procedures for Type AC and MC Cables

In addition to complying with the specific installation requirements of the NEC, Type AC and Type MC cables are required to be installed in a “neat and workmanlike manner.” To the extent practicable, visible cables should be installed in vertical or horizontal lines or otherwise follow building lines. Cables must be supported properly where they are routed around obstacles as they are inherently flexible (Figure 6.1).

Installation requirements for Type AC and MC cables are as follows:



Figure 6.1—Installation of Type MC Cable (courtesy Braggs Electric Construction)

Table 6.1

Condition	Type AC Cable	Type MC Cable
Exposed work according to the following three conditions:	Unless otherwise permitted, closely follow the surface of the building finish or running boards	Install in a neat and workmanlike manner
In suspended ceilings – fire-rated assemblies – support from ceiling assembly	Independent, identified, support wires required unless cable is a part of fire-rated assembly	
In suspended ceilings – non-fire-rated assemblies – support from ceiling assembly	Independent support wires required unless otherwise permitted by the ceiling system manufacturer	
Underside of joists	Permitted where supported at each joist and not subject to physical damage	Install in a neat and workmanlike manner
Through bored holes in wood members or where installed parallel to framing members unless fished as concealed work in finished buildings, for the following two conditions:		
Bored holes located 32 mm (1¼ in.) or more from nearest edge of stud, joist or rafter or where secured as such in parallel run	No additional protection required	

Condition	Type AC Cable	Type MC Cable
Through bored holes located less than 32 mm (1¼ in.) from nearest edge of stud, joist or rafter or where secured as such in parallel run	Install steel plate or bushing not less than 1.6 mm (1/16 in.) thick or listed equivalent over cable	
Through either factory or field punched, cut or drilled slots or holes in metal framing members	No additional protection required	
Parallel to metal framing members for the following two conditions:		
Where located 32 mm (1¼ in.) or more from nearest edge of stud, joist or rafter	No additional protection required	
Where located less than 32 mm (1¼ in.) from nearest edge of stud, joist or rafter	Install steel plate or bushing not less than 1.6 mm (1/16 in.) thick or listed equivalent over cable	
In accessible attics for the following three conditions:		
Where run across the top of floor joists or installed within 2.1 m (7 ft) of the floor or floor joists on the face of rafters or studding and the space is accessible by permanent means	Where run across the top of floor joists or installed within 2.1 m (7 ft) of the floor or floor joists on the face of rafters or studding and the space is accessible by permanent means	
Where run across the top of floor joists or installed within 2.1 m (7 ft) of the floor or floor joists on the face of rafters or studding and the space <i>is not</i> accessible by permanent means	Within 1.8 m (6 ft) of the access hole or entrance, by substantial guard strips that are at least as high as the cable	
Parallel to framing members	Guard strips or running boards are not required but installation must comply with rules for “Parallel to framing members” above	
Bending radius, Type AC Cable	The radius of the curve of the inner edge not less than five times the diameter of the cable	
Bending radius, Type MC Cable, Smooth Sheath not more than 19 mm (¾ in.) in external diameter.		Ten times the external diameter of the metallic sheath
Bending radius, Type MC Cable, Smooth Sheath more than 19 mm (¾ in.) but not more than 38 mm (1½ in.) in external diameter.		Twelve times the external diameter of the metallic sheath
Bending radius, Type MC Cable, Smooth Sheath more than 38 mm (1½ in.) in external diameter		Fifteen times the external diameter
Bending radius, Type MC cable, Interlocked-Type Armor or Corrugated Sheath.		Seven times the external diameter of the metallic sheath

Condition	Type AC Cable	Type MC Cable
Securing and supporting	As indicated below	
General requirements	At intervals not exceeding 1.4 m (4½ ft) and within 300 mm (12 in.) of every outlet box, junction box, cabinet, or fitting	At intervals not exceeding 1.8 m (6 ft). Cables containing four or fewer conductors, sized no larger than 10 AWG, shall be secured within 300 mm (12 in.) of every box, cabinet, fitting, or other cable termination.
Horizontal Runs Through Holes and Notches	Additional support is not required where support complies with general requirements	
Methods of support – all methods designed so as to not damage the cable	By staples, cable ties, straps, hangers or similar fittings	
Unsupported cables – cables are not required to be supported under any of the following three conditions:		
The cable is fished between access points	Where cable is concealed in finished buildings or structures and supporting is impracticable	
Where flexibility is necessary	Cable is not more than 600 mm (2 ft) in length at terminals	Install in a neat and workmanlike manner
For connections within an accessible ceiling to luminaire(s) [(lighting fixture(s))] or equipment.	Cable is not more than 1.8 m (6 ft) long from the last point of support	

6.2 Planning for and Installation of Home Runs

6.2.1 Planning

Branch-circuit panelboards typically have spaces for up to 42 branch circuits while the number of knockouts on the top or bottom of the enclosure for cable entries is less than that. Where panelboards are located in spaces where future access may be difficult, spare cables or raceways should be installed to an accessible location. A tag or other notation should be made at both ends of this spare cable or raceway to indicate its location.

6.2.2 Home Run Cables

Home-run cables are available with three or more insulated branch circuit conductors. They are typically produced with 8, 12 or 16 insulated conductors but may be manufactured with any number of insulated conductors. They may have

a neutral for each set of two or three ungrounded conductors (multiwire branch circuits) or a neutral for each ungrounded (phase) conductor. The home run cables are installed from the branch circuit panelboard to a junction box where individual branch circuit cables are extended.

6.2.3 Phasing of Circuit Conductors

It is important to connect the conductors in home run cables correctly to ensure common conductors such as a neutral or grounded conductor are not overloaded. For single-phase circuits, one ungrounded conductor is connected to the A and B phase breaker or fuse with the neutral connected to the neutral terminal bar. For three-phase circuits, one ungrounded conductor is connected to the A, B and C phase breaker or fuse with the neutral connected to the neutral terminal bar. These circuits are referred to in the NEC as multiwire branch circuits.

6.2.4 Application of Adjustment Factors

Generally, where more than 3 conductors in a cable or raceway are considered current-carrying and are installed for a length longer than 600 mm (24 in.) without maintaining spacing, the allowable ampacity of the conductors must be reduced according to the following table:

Table 6.2.4

Number of Current-Carrying Conductors	Percent of Allowable Ampacity
4-6	80
7-9	70
10-20	50
21-30	45
31-40	40
41 and above	35

This table also generally applies where multiconductor cables are stacked or bundled longer than 600 mm (24 in.) without maintaining spacing. The table does not apply to conductors in nipples not longer than 600m (24 in.).

Application of an adjustment factor (derating) for the number of current-carrying conductors is not required where Type AC or MC cables that do not have an overall outer jacket are installed as follows:

1. Each cable has not more than 3 current-carrying conductors
2. The circuit conductors are 12 AWG copper

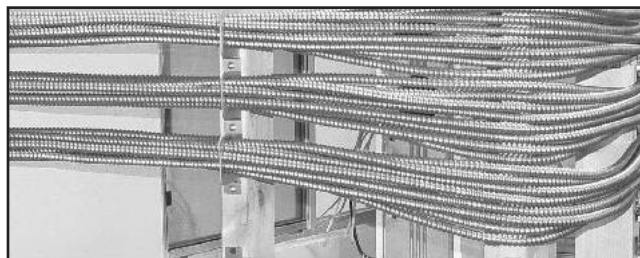

Figure 6.2.4—Support bracket designed to space cables. (Courtesy Erico, Caddy Division)

3. Not more than 20 current-carrying conductors are installed without maintaining spacing, stacked or supported on bridle rings.

A 60 percent derating adjustment must be made if the number of current-carrying conductors in these cables that are installed longer than 600 mm (24 in.) without maintaining spacing exceeds 20 (Figure 6.2.4).

An example is: 8, 3-wire cables are installed longer than 24 in. without maintaining spacing and the neutral conductors are not considered to be current-carrying. No adjustment factor is required as this installation has 16 current-carrying conductors. (8 x 2 = 16)

Another installation has 8, 4-wire cables installed without maintaining spacing longer than 24 in. and the neutral conductors are considered to be current-carrying. Application of a 60% adjustment factor is required as this installation has 32 current-carrying conductors (8 x 4 = 32). The allowable ampacity of each 12 AWG conductor having THHN/THWN insulation where the cable is installed in a dry location is: 30 amperes x .6 = 18 amperes

6.2.4.1 When the Neutral Counts as Current-Carrying

The neutral *does not* count as a current-carrying conductor when it carries only the unbalanced current from other conductors of the same circuit such as a 3-wire cable for a 120/240 volt multiwire branch circuit.

The neutral *does* count as a current-carrying conductor under either of the following conditions:

1. A 3-wire circuit consisting of two phase wires and the neutral of a 4-wire, 3-phase, wye connected system since the neutral carries approximately the same current as the ungrounded conductors.
2. A 4-wire, 3-phase circuit where the major portion of the load consists of nonlinear loads as harmonic currents are present in the neutral conductor. Nonlinear loads include circuits for computers and inductive lighting such as fluorescent.

6.3 Cutting AC and MC Cables

There are three methods for cutting the armor of Type AC and MC cables. Cable manufacturers recommend the first method below, using a rotary cutter, because this avoids damaging the insulated conductors inside the cable.

1. Rotary armor cutter
2. Hacksaw
3. Wire cutters such as diagonal cutters or lineman pliers

6.3.1 Rotary Armor Cutter

Rotary cutters are designed specifically for safely cutting Type AC and MC cable armor. They are available in various sizes to accommodate a range of cable sizes. Select the appropriate rotary cutting tool for the size of cable to be cut. The cutter has an adjustable anvil that, when adjusted properly, secures the cable in the tool when the handle is squeezed. A few turns of the handle make a cut through the cable armor without a risk of damage to the insulated conductors. The severed armor is then slid off the conductors. After cutting the armor, it is important to remove sharp angles and edges of the cut armor convolution. This is to ensure no protruding edges of the remaining cut convolutions are able to penetrate the end stops of the connectors.

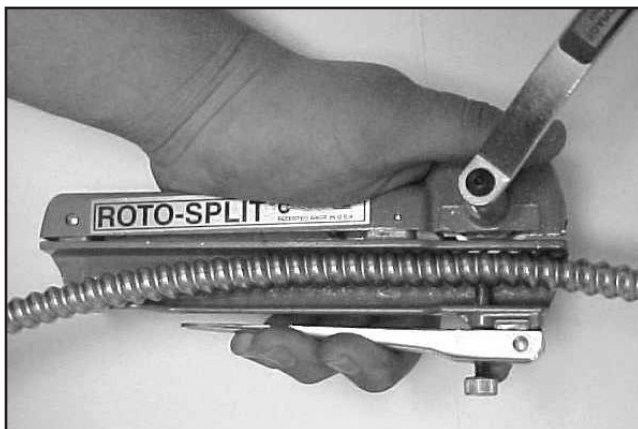

Figure 6.3—Roto Split (courtesy Alflex Cable)

6.3.2 Hacksaw

Use a sharp hacksaw blade having at least 32 teeth per inch, installed in a heavy-duty frame (be sure the blade is taut in the frame). Secure the Type AC or MC cable in a vise or support it on a block of wood. Cut one of the armor convolutions at an approximate 60-degree angle. Be careful not to cut any deeper than necessary to avoid damage to the insulated conductors.

6.3.3 Wire Cutters

Using a wire cutter to cut AC or MC cable armor requires either breaking the armor or unwinding it. “Breaking the armor” involves bending the cable at the point where the cut is desired and twisting the armor slightly so the cutting pliers can be inserted between the conductors and the armor. The armor must be twisted back into the convolutions before it is inserted into the connector. This is where the conductors can be damaged, since the armor often has a sharp edge from the cutting process.

6.3.4 Caution

Cutting the cable armor using any of the three methods can leave a sharp edge. Protecting one’s hands from cuts and abrasions by wearing suitable work gloves should be considered.

Protect the insulated conductors in the cable from any sharp edges of the armor during handling and installation of the insulating bushing and fitting on Type AC cable and the installation of the fitting on Type MC cable.

6.4 Position of Cable in Connector

To ensure adequate mechanical securement, the cable should be inserted into the connector until it is flush with but not extend through the connector’s end stop. Screws or direct-bearing tabs provided on some connectors or box clamps should be positioned to seat between convolutions of the armor sheath. Fittings with direct bearing screws are permitted only on cables with steel armor (Figure 6.4, next page).

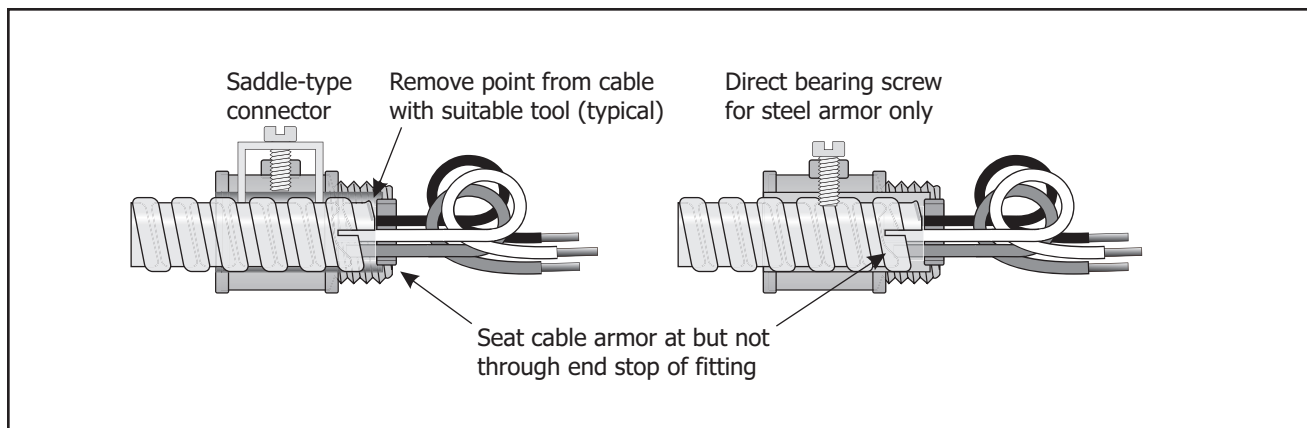

Figure 6.4—Position of cable in connector

6.5 Overcurrent Protection and Derating

6.5.1 Type AC Cables

Type AC cables are required to be protected from overcurrent in accordance with their ampacity. Generally, the ampacity of Type AC cable is determined from Table 310.15(B)(16). Other requirements must be met as well such as overcurrent protection of small conductors, derating where more than 3 current-carrying conductors are grouped or installed without maintaining spacing (see the exception for where not more than 20, 12

AWG conductors are bundled) or where the cable is installed in thermal insulation. Also, where cables are installed in ambient temperatures higher than 86°F, the allowable ampacity of the conductors must be corrected (derated) according to the values in the correction factors in Table 310.15(B)(2)(a). Since Type AC cables are typically manufactured with 90°C conductor insulation, all derating is done from the 90°C conductor ampacity. (Type ACTH cables will have 75°C conductor insulations.)

Type AC cables in cable tray. Comply with NEC Article 392 on cable trays.

Table 6.5.1 Overcurrent Protection and Derating of Type AC Cables

Conductor Size AWG	90°C Ampacity ¹	Small Conductor Ampacity	Through 20 wires Bundled ^{2, 4}	More than 20 wires Bundled ^{3, 4}	In Thermal Insulation
14	25	15	—	—	15
12	30	20	30	18	20
10	40	30	—	—	30

¹ Assume copper conductors

² Not more than 3 current-carrying conductors per cable and not more than 20 current-carrying conductors grouped or bundled. Observe temperature limitations of terminations.

³ Not more than 3 current-carrying conductors per cable and more than 20 current-carrying conductors grouped or bundled. Observe temperature limitations of terminations.

⁴ See Table 310.15(B)(3)(a) for installations indicated by dash marks.

Table 6.5.2 Overcurrent Protection and Derating of Type MC Cables

Conductor Size AWG	90°C Ampacity ¹	Small Conductor Ampacity	Through 20 wires Bundled ^{2, 4}	More than 20 wires Bundled ^{3, 4}
14	25	15	—	—
12	30	20	30	18
10	40	30	—	—

¹ Assume copper conductors

² Not more than 3 current-carrying conductors per cable and not more than 20 current-carrying conductors grouped or bundled. Observe temperature limitations of terminations.

³ Not more than 3 current-carrying conductors per cable and more than 20 current-carrying conductors grouped or bundled. Observe temperature limitations of terminations.

⁴ See Table 310.15(B)(3)(a) for installations indicated by dash marks.

6.5.2 Type MC Cables

Type MC cables are required to be protected from overcurrent in accordance with their ampacity. Generally, the ampacity of Type MC cable rated through 600 volts is determined from Table 310.15(B) (16) for conductors sized 14 AWG through 2000 kcmil. Other requirements must be met as well such as overcurrent protection of small conductors, derating where more than 3 current-carrying conductors are grouped or installed without maintaining spacing (see the exception for where not more than 20, 12 AWG are bundled). Also, where cables are installed in ambient temperatures higher than 86°F, the allowable ampacity of the conductors must be derated according to the values in the correction factors table. Since Type MC cables are typically manufactured with THHN/THWN conductor insulation, all derating is done from the 90°C conductor ampacity. In wet locations, derate from the 75°C ampacity column of Table 310.15(B)(16).

Type MC cables in cable tray. Comply with NEC Article 392 on cable trays.

6.6 Fishing Cables

Type AC and MC cables in the branch circuit sizes are particularly well suited to being fished into finished walls, floors and ceilings. Cables are permitted to be fished between access points without securing them to the framing or structural members

where concealed in finished buildings or structures and supporting the cable is impracticable. Fishing the cable can be done from access points at the top or bottom of the wall. Fishing cables across ceilings or walls can be accomplished from one or more access points to the outlet location.

Knowledge of the construction method used in the structure is critical. It is always easier to fish cables parallel to the studs or ceiling or floor joists. At times, it is necessary to drill through blocking or through floor or ceiling framing members to complete the run. This can sometimes be done with a drill bit on a long flexible shaft. At times, the drill bit can be used to pull the cable back through the hole into the outlet or access point. Where drilling through blocking or framing members cannot be accomplished, it is necessary to cut access holes near the obstacle. The blocking or framing member can then be drilled through or a shallow groove cut into the framing member. Be certain cutting a groove in the framing member is acceptable in the applicable building code. Where installed in a shallow hole or groove, install nail plates over the cable to protect it from potential damage.

Cut the hole for the outlet box during the planning stage. Fish the cable into the hole for the box. Cut the armor back long enough to leave the free conductor length desired and secure it to the box. Slide the box into the hole and secure it to the building finish. Some “old work boxes” contain a strap that rotates

behind the building finish when the mounting screw is turned. Caution should be exercised about the weight of the luminaire (lighting fixture) to be supported from outlet boxes that are not secured to a structural member but to only the building finish.

6.7 Installing Cables Through Fire-Rated Walls, Floors or Ceilings

Walls, floors and ceilings in some cases are required to have a fire-resistance rating. This rating is often designated as a resistance to the spread of fire such as 1-hour, two-hours and so forth by the applicable local building code. Designation of the fire rating may appear on construction drawings. The installation of cables or other wiring methods must not reduce or negate the rating of these fire-rated assemblies and must prevent the passage of smoke, gases and flames from one area to another.

The methods for maintaining the fire rating of walls, floors or ceilings can be defined as fire-stopping, installing the cables as part of a fire-rated assembly or as a Through-Penetration Fire-Stop system. Type AC and MC cables are well suited for installation in fire-rated walls, floors and ceilings.

For fire stopping, the fire-resistance can be obtained by sealing the openings around cables by using an approved method such as fire caulking or pads where the cables pass through a rated wall, floor or ceiling.

Many listed firestopping systems are available. The installation instructions for the product must be strictly followed (*Figure 6.7*).

Fire rated assemblies are included in the Underwriters Laboratories Fire Resistance Directories. UL classified Through Penetrating Products for armored cable installations can be found online in UL's Certification Directory using the following link: <http://database.ul.com/cgi-bin/XYV/template/LISEXT/1FRAME/index.html> and the UL Category Code for "Through Penetrating Products (XHLY)." These assemblies, which include the wiring methods permitted, have been tested to determine their fire resistance as an assembly. It is important to remember that no deviation can be made from the components used in the assembly or from the manner in which they are installed.

Through-Penetration Fire-Stop systems include specially designed components that are installed on the job such as blocks with inserts where cables in cable trays pass through fire rated walls. These systems must be installed in accordance with all applicable building codes as well as the instructions provided by the manufacturer and in the product listing.

Be certain cables are protected from physical damage where they pass through floors. This protection can be provided by installation in protective conduit sleeves.

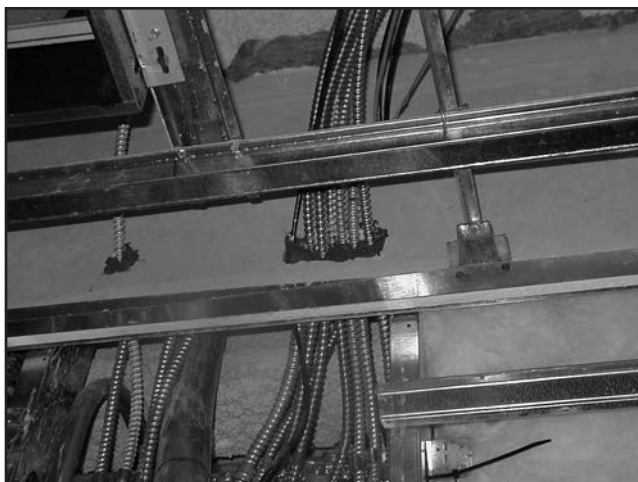

Figure 6.7—Firestopping through penetrations

7. AC Cables—Specific Installation Procedures

7.1 Boxes and Fittings

a) *Cable splices and terminations* must be made in an enclosure, box, or other suitable fitting such as a conduit body. Adequate space is required for all conductors in the box or fitting.

b) *Connectors or fittings* used to connect AC cable to the box or fitting must protect the conductors from abrasion, unless the design of the outlet box or fitting provides the required protection. Listed fittings for Type AC cable provide the required protection. To ensure adequate mechanical securement, the cable should be inserted into the connector until it is flush with the connector's end stop. Screws or direct-bearing tabs provided on some connectors or box clamps should be positioned to seat between convolutions of the armor sheath. Fittings with direct bearing screws are permitted only on cables with steel armor. See Figure 6.4.

c) *Armored Cable Anti-Short Bushing* (commonly known in the electrical trade as “red heads”) must be provided at AC cable terminations. They are inserted between the conductors and the armor to protect the conductor insulation from damage by sharp edges of cut metal. A good practice for holding insulating bushings in place is to bend back the cable's internal bonding strip over the bushing and back-wrap the strip into the convolutions of the armor. The AC connector or clamp must be designed so the insulating bushing or equivalent protection is visible for inspection after installation.

7.2 Isolated Equipment Grounding

The NEC permits isolated equipment grounding for the reduction of electrical noise.

Type AC cable with an insulated equipment grounding conductor provides two independent grounding paths. This makes it suitable for isolated equipment grounding. The first path is the outer armor of the cable, together with the bare 16 AWG aluminum bonding strip. The second path is the insulated equipment grounding conductor.

The AC cable armor makes a grounding connection to the metal outlet box when properly installed. The insulated equipment grounding conductor connects to the isolated grounding terminal of the receptacle or other equipment. The insulated equipment grounding conductor is permitted to pass through one or more panelboards. It must be connected at the first of the following:

1. Source of the separately derived system supplying power to the circuit.
2. Building disconnecting means.
3. Service equipment.

7.3 Health Care Facilities

Branch circuits in patient care areas of health care facilities are required to provide two independent equipment grounding paths for all receptacles and all non-current-carrying conductive surfaces of fixed electric equipment that is likely to become energized and is subject to personnel contact. When cable wiring methods are used, the cable armor must provide one of the equipment grounding paths. In addition, there must be an insulated equipment grounding conductor in the cable.

AC cable with an insulated equipment grounding conductor complies with this NEC requirement. The first path is the outer armor of the cable, together with the bare 16 AWG aluminum bonding strip. The

second path is the insulated equipment grounding conductor. Cables of this configuration are suitable for installation in patient care areas of health care facilities (*Figure 7.3*).

The cable armor serves as the equipment grounding conductor to ground the metal receptacle box or other equipment such as a box for light switches. The second insulated equipment grounding conductor must be connected to the box. A bonding jumper must be installed to the equipment grounding terminal of the receptacle or switch.

7.3.1 Emergency Systems in Health Care Facilities

Type AC cable is not generally permitted to be installed for emergency system circuits in a hospital, or in other health care facilities such as outpatient surgeries which have electrical life support equipment or critical care areas. No similar limitation exists for nursing homes, limited care facilities, clinics, medical and dental offices and ambulatory care facilities.

Type AC cable is permitted for these emergency system circuits where:

1. Used in prefabricated medical headwalls
2. Used in listed office furnishings
3. Fished into existing walls or ceilings that are not otherwise accessible and the cable is not subject to physical damage

4. Where necessary for flexible connection to equipment

Type AC cables installed in patient care areas must comply with the rules for grounding.

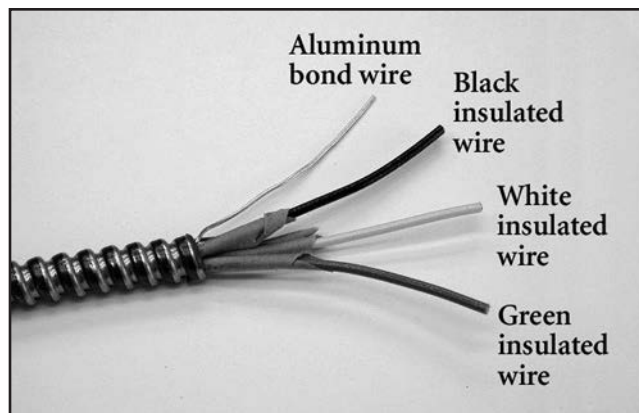

Figure 7.3—Type AC Health Care Cable

8. MC Cables—Specific Installation Procedures

8.1 Boxes and Fittings

a) *Cable splices and conductor terminations* must be made in an enclosure, box, or other suitable fitting such as a conduit body. Adequate space is required for all conductors in the box or fitting.

b) *Connectors or fittings* used to connect MC cable to the box or fitting must protect the conductors from abrasion, unless the design of the outlet box or fitting provides the required protection. Listed fittings for Type MC cable provide the required protection. To ensure adequate mechanical securement, the cable should be inserted into the connector until it is flush with the connector's end stop. Screws or direct-bearing tabs provided on some connectors or box clamps should be positioned to seat between convolutions of cables having interlocked metal sheath or corrugated metal sheath construction. Fittings with direct bearing set screws are permitted only on steel armored cables. See Figure 6.4.

c) *Armored Cable Anti-Short Bushing* (commonly known in the electrical trade as “red-heads”) are not required by the NEC to be provided at MC cable terminations. However, good trade practice dictates that they be installed to protect the conductor insulation from damage by sharp edges of cut metal. Insulating bushing are often shipped by the cable manufacturer with coils or reels of MC cable. Anti-short bushings that may be supplied by Type MC cable manufacturers are for optional use by the installer. Such use is not required.

d) *Bonding* of connectors to the cable's armor sheath requires direct metal-to-metal contact. When assembling a connector to cable having a PVC outer jacket, sufficient jacket must be removed to permit proper seating of the connector or its clamp directly on the armor sheath.

8.2 Isolated Equipment Grounding

The NEC permits isolated equipment grounding for the reduction of electrical noise.

MC cable with smooth or corrugated metal sheath is permitted to be used for isolated equipment grounding when it contains a separate insulated equipment grounding conductor.

MC cable with spiral interlocking metal sheath is permitted to be used for isolated equipment grounding when it contains two separate insulated equipment grounding conductors. The first has a continuous green insulation. The second has green insulation with a yellow stripe.

The first equipment grounding conductor or MC cable armor (where this is listed as an equipment grounding conductor) is connected to the metal receptacle box. The second equipment grounding conductor connects to the equipment grounding terminal of the isolated ground receptacle.

8.3 Health Care Facilities

Branch circuits in patient care areas of health care facilities are required to provide two independent equipment grounding paths for all receptacles and all non-current-carrying conductive surfaces of fixed electric equipment that is likely to become energized and is subject to personnel contact. When cable wiring methods are used, the cable armor must provide one of the equipment grounding paths. In addition, there must be an insulated equipment grounding conductor.

Type MC cable of the smooth or corrugated tube type that does not have a bare or green-insulated equipment grounding conductor but has a green insulated equipment grounding conductor with a

yellow stripe or a surface marking or both to indicate that it is an additional isolated grounding conductor indicates that the sheath of the cable is itself suitable as an equipment grounding conductor. Cable of this construction is permitted in patient care areas of health care facilities.

The cable armor serves as the equipment grounding conductor to ground the metal receptacle box or other equipment such as a box for light switches. The second insulated equipment grounding conductor must be connected to the box. A bonding jumper must be installed to the equipment grounding terminal of the receptacle or switch.

8.3.1 Emergency Systems in Health Care Facilities

See the table in 8.3 for an identification of Type MC cable permitted to be installed for emergency system circuits in a hospital, or in other health care facilities such as outpatient surgeries which have electrical

life support equipment or critical care areas. No similar limitation exists for nursing homes, limited care facilities, clinics, medical and dental offices and ambulatory care facilities.

If installed in accordance with 517.30(C)(3), Type MC cable is permitted for these emergency system circuits where:

1. Used in prefabricated medical headwalls.
2. Used in listed office furnishings.
3. Fished into existing walls or ceilings that are not otherwise accessible and the cable is not subject to physical damage.
4. Where necessary for flexible connection to equipment.

Type MC cables installed in patient care areas must comply with the rules for grounding.

Table 8.3 Type MC for Use in Patient Care Areas of Health Care Facilities

Type of MC Cable	Equipment Grounding Paths	Permitted in Other than Patient Care Areas	Permitted for Patient Care Area Branch Circuits for	
			Normal	Critical/Life Safety ¹
MCI	1 - Bare or insulated equipment grounding conductor	Yes	No	No
(MCI-A)	1 – metal armor with full-sized aluminum grounding/bonding conductor 2 – insulated copper equipment grounding conductor not smaller than 12 AWG	Yes	Yes	Yes
MCS	1 – aluminum armor without bare equipment grounding conductor 2 – insulated copper equipment grounding conductor not smaller than 12 AWG	Yes	Yes	Yes
MCC	1 – aluminum armor without bare equipment grounding conductor 2 – insulated copper equipment grounding conductor not smaller than 12 AWG	Yes	Yes	Yes

¹As permitted in 517.30(C)(3)

8.4 Terminating Type MC Cable Containing Bare Aluminum Bonding/ Grounding Conductor

Manufacturer installation instructions typically include the following:

1. Cut the cable to the length needed anticipating the length of conductors needed after the armor is removed such as for receptacle outlets, junction boxes or panelboards.
2. Cut the armor using a rotary cutting tool designed for use with interlocked armor Type MC cable or by other acceptable method and remove the armor. After cutting the armor, it is important to remove sharp angles and edges of the cut armor convolution. This is to ensure no protruding edges of the remaining cut convolutions are able to penetrate the end stops of the connectors.
3. Separate the aluminum grounding/bonding conductor from the cable assembly by folding back approximately 120 degrees.
4. Cut the aluminum grounding/bonding conductor flush with the end of the cable with a suitable tool.
5. Select a properly sized fitting that is listed and identified for Metal Clad Interlocking Armor Ground cable (MCI-A). Install the fitting in accordance with the manufacturer's instructions to provide an effective ground-fault return path.
6. *Optional Installation Method:* Though not required, the aluminum bonding/grounding conductor may be terminated inside the box or enclosure using connectors that are suitable for the conductor material in accordance with NEC requirements, conditions in the product listing, and manufacturer instructions.

9. Type MC Cables in Hazardous (Classified) Locations

Certain NEC Articles permit Type MC cable to be installed in or above hazardous (classified) locations under specific conditions. See Table 9.1, next page.

9.1 Class I Locations

Standard MC cable is not permitted to be used in Class I, Division 1 locations. Under certain conditions, it can be installed above a Class I, Division 1 area, but not within, the hazardous (classified) location. Standard Type MC cable is permitted within Class I, Division 2 locations.

Type MC-HL cable is specially designed, manufactured, and listed for use in Class I, Division 1 hazardous locations. It has a gas/vaportight continuous corrugated metallic sheath, an overall jacket of suitable polymeric material, separate grounding conductors in accordance with NEC 250.122, and is provided with termination fittings listed for the application.

9.2 Class II Locations

Standard MC cable is not permitted to be used in Class II, Division 1 hazardous locations. Under certain conditions, it can be installed above a Class II, Division 1 area, but not within, the hazardous (classified) location. Standard Type MC cable is permitted within Class II, Division 2 locations.

Type MC-HL cable is specially designed, manufactured, and listed for use in Class II, Division 1 hazardous locations. It has a gas/vaportight continuous corrugated metallic sheath, an overall jacket of suitable polymeric material, separate grounding conductors in accordance with NEC 250.122, and is provided with termination fittings listed for the application.

9.3 Seals in Hazardous (Classified) Locations

NEC requirements for sealing cable installations must be observed to minimize the passage of gasses and vapors and prevent the passage of flames from one portion of the electrical installation to another.



Table 9.1 Hazardous (Classified) Locations

Area or Occupancy	Area Classification	Type of MC cable
In industrial establishments with restricted public access, where the conditions of maintenance and supervision ensure that only qualified persons service the installation	Class I, Div. 1	MC-HL
Unless otherwise provided, any occupancy having a Class I, Division 2 area	Class I, Div. 2	Standard ¹
Nonincendive field wiring	Any classified area	Standard
In industrial establishments with restricted public access, where the conditions of maintenance and supervision ensure that only qualified persons service the installation	Class II, Div. 1	Cable listed for Class II, Div. 1
Any occupancy having a Class II, Division 2 area	Class II, Div. 2	Standard, & cable tray ²
Any occupancy having a Class III, Division 1 area	Class III, Div. 1	Standard
Any occupancy having a Class III, Division 2 area	Class III, Div. 2	Standard
Intrinsically safe systems	Any	Standard
Class I, Zone 0 locations	Class I, Zone 0	Standard
Class I, Zone 1 locations	Class I, Zone 1	MC-HL ³
Class I, Zone 2 locations	Class I, Zone 2	Standard
Commercial Garages, Repair and Storage	Above Class I	Standard
Aircraft Hangars	Not in Class I	Standard
Motor Fuel Dispensing Facilities	Above Class I	Standard
Bulk Storage Plants	Above Class I	Standard
Spray Application, Dipping, and Coating Processes	Above Class I or Class II	Standard

¹ Type MC cable listed for Class I, Division 1 area is also permitted in a Class I, Division 2 area

² Type MC cable listed for Class II, Division 1 area is also permitted in a Class II, Division 2 area

³ In industrial establishments with restricted public access, where the conditions of maintenance and supervision ensure that only qualified persons service the installation

(This annex is not part of the standard)

Annex A: Reference Standards

This publication, when used in conjunction with the National Electrical Code and generator manufacturers' literature, provides sufficient information to install armored cable and metal-clad cable. The following publications may also provide useful information:

National Fire Protection Association
1 Batterymarch Park
P.O. Box 9101
Quincy, MA 02269-9101
(617) 770-3000
(617) 770-3500 fax
www.nfpa.org

NFPA 70-2011, *National Electrical Code* (ANSI)

Current *National Electrical Installation Standards*™ Published by NECA:

National Electrical Contractors Association
3 Bethesda Metro Center, Suite 1100
Bethesda, MD 20814
(301) 215-4504 tel, (301) 215-4500 fax
www.neca-neis.org

NECA 1-2010, *Standard for Good Workmanship in Electrical Construction* (ANSI)

NECA 90-2009, *Recommended Practice for Commissioning Building Electrical Systems* (ANSI)

NECA 100-2006, *Symbols for Electrical Construction Drawings* (ANSI)

NECA 101-2006, *Standard for Installing Steel Conduits (Rigid, IMC, EMT)* (ANSI)

NECA 102-2004, *Standard for Installing Aluminum Rigid Metal Conduit* (ANSI)

NECA/AA 104-2006, *Recommended Practice for Installing Aluminum Building Wire and Cable* (ANSI)

NECA/NEMA 105-2007, *Recommended Practice for Installing Metal Cable Tray Systems* (ANSI)

NECA 111-2003, *Standard for Installing Nonmetallic Raceways (RNC, ENT, LFNC)* (ANSI)

NECA/NACMA 120-2012, *Standard for Installing Armored Cable (AC) and Metal-Clad Cable (MC)* (ANSI)

NECA 130-2010, *Standard for Installing and Maintaining Wiring Devices* (ANSI)

NECA/NACMA 120 Standard for Installing Armored Cable (AC) and MetalClad Cable (MC)

NECA 169-2010, *Standard for Installing and Maintaining Arc-Fault Circuit Interrupters (AFCIs) and Ground-Fault Circuit Interrupters (GFCIs)* (ANSI)

NECA 200-2010, *Recommended Practice for Installing and Maintaining Temporary Electric Power at Construction Sites* (ANSI)

NECA 202-2006, *Standard for Installing and Maintaining Industrial Heat Tracing Systems* (ANSI)

NECA 230-2010, *Standard for Selecting, Installing, and Maintaining Electric Motors and Motor Controllers* (ANSI)

NECA/FOA 301-2009, *Standard for Installing and Testing Fiber Optic Cables* (ANSI)

NECA 303-2005, *Standard for Installing Closed-Circuit Television (CCTV) Systems* (ANSI)

NECA 305-2010, *Standard for Fire Alarm System Job Practices* (ANSI)

NECA 331-2009, *Standard for Building and Service Entrance Grounding and Bonding*

NECA 400-2007, *Standard for Installing and Maintaining Switchboards* (ANSI)

NECA 402-2007, *Recommended Practice for Installing and Maintaining Motor Control Centers* (ANSI)

NECA/EGSA 404-2007, *Standard for Installing Generator Sets* (ANSI)

NECA 406-2003, *Standard for Installing Residential Generator Sets* (ANSI)

NECA 407-2009, *Standard for Installing and Maintaining Panelboards* (ANSI)

NECA 408-2009, *Standard for Installing and Maintaining Busways* (ANSI)

NECA 409-2009, *Standard for Installing and Maintaining Dry-Type Transformers* (ANSI)

NECA 410-2005, *Standard for Installing and Maintaining Liquid-Filled Transformers* (ANSI)

NECA 411-2006, *Standard for Installing and Maintaining Uninterruptible Power Supplies (UPS)* (ANSI)

NECA 412-2012, *Standard for Installing and Maintaining Photovoltaic (PV) Power Systems* (ANSI)

NECA 413-2012, *Standard for Installing and Maintaining Electric Vehicle Supply Equipment* (ANSI)

NECA 420-2007, *Standard for Fuse Applications* (ANSI)

NECA 430-2006, *Standard for Installing Medium-Voltage Metal-Clad Switchgear* (ANSI)

NECA/IESNA 500-2006, *Standard for Installing Indoor Commercial Lighting Systems* (ANSI)

NECA/IESNA 501-2006, *Standard for Installing Exterior Lighting Systems* (ANSI)

NECA/IESNA 502-2006, *Standard for Installing Industrial Lighting Systems* (ANSI)

NECA 503-2005, *Standard for Installing Fiber Optic Lighting Systems*

NECA/BICSI 568-2006, *Standard for Installing Commercial Building Telecommunications Cabling* (ANSI)

NECA/MACSCB 600-2003, *Recommended Practice for Installing and Maintaining Medium-Voltage Cable* (ANSI)

NECA/NEMA 605-2005, *Recommended Practice for Installing Underground Nonmetallic Utility Duct* (ANSI)

NECA/BICSI 607-2011, *Standard for Telecommunications Bonding and Grounding Planning and Installation Methods for Commercial Buildings*

NECA 700-2010, *Standard for Installing Overcurrent Protection to Achieve Selective Coordination* (ANSI)

<This page intentionally left blank>

<This page intentionally left blank>

MEMBERS - NATIONAL ARMORED CABLE MANUFACTURERS ASSOCIATION

AFC Cable Systems, Inc.

960 Flaherty Drive
New Bedford, MA 02745
Phone: 800-757-6996
Fax: 508-998-1447
www.afcweb.com

Encore Wire Corporation

1329 Millwood Rd
McKinney, TX 75069
Phone: 972-562-9473
Fax: 972-562-3644
www.encorewire.com

General Cable

4 Tesseneer Drive
Highland Heights, KY 41076
Phone (859) 572-8000
Fax (859) 572-8058
www.generalcable.com

Southwire Company

One Southwire Drive
Carrollton, GA 30119
Phone: 770-832-4242
Fax: 770-832-5047
www.southwire.com

United Copper Industries

2727 Geesling Road
Denton, TX 76208
Phone: 940-243-7676
Fax: 940-243-7777
www.unitedcopper.com



www.nacmaonline.com