

# PYROMATECO

## Installation Instructions PYROMAT ECO 35 to ECO 151



© by K b Holzheizsysteme GmbH  
Flotzbachstra e 33  
A-6922 Wolfurt  
All rights reserved, including photomechanical re-  
production and storage in electronic media.

Viessmann Group

<b>1</b>	<b>General information</b>	<b>1</b>
1.1	Technical standing	1
1.2	Information documented	1
<b>2</b>	<b>Important information</b>	<b>1</b>
2.1	Safety information	1
2.2	Official permits	1
2.3	Standards and regulations	1
<b>3</b>	<b>The structural surroundings of the burner</b>	<b>2</b>
3.1	Heating room requirements	2
3.2	The chimney connection	2
<b>4</b>	<b>The water installations</b>	<b>2</b>
4.1	The safety equipment	2
4.2	Expansion	2
4.3	The burner circuit with burner control valve and storage unit valve	2
<b>5</b>	<b>The electrical installations</b>	<b>3</b>
5.1	The positioning of the control module and control system module	3
5.2	Electrical connection	3
<b>6</b>	<b>Fire protection</b>	<b>3</b>
6.1	Fire protection for the fuel storage space	3
<b>7</b>	<b>Initial Start-up</b>	<b>3</b>
7.1	Filling the heating system	3
7.2	The fuel for the initial start-up	3
7.3	Inspecting the installation	4
7.4	Initial start-up and handover	4
<b>8</b>	<b>Spec sheets</b>	
2960-1, 2	Wood-burning PYROMAT-ECO, Installation, Closed System	
2960-3, 4	Wood-burning PYROMAT-ECO, Installation, Open System	
4500-1	Water-bearing Components, Burner Safety Devices	
4600-1, 2, 3	Water-bearing Components, Heat Distribution	
2010-1, 2, 3, 4, 5	Burner System, PYROMAT-ECO	
2110-1	Accessories for PYROMAT-ECO, Conducting Exhaust Gas / Cleaning	
2200-1	Accessories for the PYROMAT-ECO, Functions of the burner	
4000-1	ECOTRONIC Heating Control Unit, Equipping	
4020-1, 2, 3	ECOTRONIC Heating Control Unit, Module Extension, Data Transmission Lines	
4030-1, 2	ECOTRONIC Heating Control Unit, Additional Heat Generators	
4040-1, 2	ECOTRONIC Heating Control Unit, Heat Consumer	
4050-1, 2	ECOTRONIC Heating Control Unit, Solar Energy	
4090-1	ECOTRONIC Heating Control Unit, Visualisation & Remote Maintenance	
1120-1, 2	Installation Services	
1010-1, 2	Wood Fuels, Minimum Requirements / Instructions	
1000-1, 2	General Terms of Delivery	
Supplement	EC attestation of conformity	

# **1 General information**

Only specialists may set up and put into operation K b solid fuel burners. This will rule out any faulty installation or initial start-up. These instructions are therefore limited to important technical data, references to ordinances, technical rules and other regulations.

The PYROMAT ECO is a Burner Class 3 boiler for heating systems with hot water with a protection temperature of 110  C as per EN 303-5: 1999 (heating boilers for solid fuels, manual and automatically loaded combustion systems).

## **1.1 Technical standing**

The operating instructions comply with the PYROMAT ECO at the time of its delivery. In the interest of our customers, we reserve the right to make the following alterations as a result of technical developments, without being under obligation to give notification of such.

## **1.2 Information documented**

The installation instructions contain the information required according to the EC Directive "Machinery 98/37/EEC, Appendix 1, Number 1.7.4.

# **2 Important information**

## **2.1 Safety information**

The water-bearing and electrical installations as well as the chimney connection must be carried out by individuals authorised to do so, complying with all relevant standards and safety regulations.

## **2.2 Official permits**

The PYROMAT ECO has been inspected and approved in compliance with European Standard EN 303-5:1999. In addition, the PYROMAT ECO meets all European national deviations relating to tightened regulations relevant to emission limits and efficiencies:

### **Austria:**

Art. 15a of the *B-VG*

"Agreement on the Saving of Energy"

"Agreement on Protective Measures Concerning Small Furnaces"

Federal Law Gazette

Ordinance 331

Furnace Ordinance

FAV dated 18 Nov 1997, Part II

### **Germany:**

German Federal Emissions Control Act

"Small Furnaces Ordinance, 1<sup>st</sup> German Federal Emissions Control Act" dated 1997-03-14

### **Switzerland:**

The Clean Air Act (or "*LRV*") dated 16 Dec 1985, incl. the amendment dated 20 Nov 1991

### **Netherlands:**

NeR

Dutch guideline on the incineration of clean remnant wood of June 1995

**You can find out from your local building authority whether the PYROMAT ECO requires an official permit. This is why you should report there your installation of the PYROMAT ECO.**

## **2.3 Standards and regulations**

- Hot-water heating systems: Safety equipment DIN 4751,  NORM B 8130 [Austrian standard],  NORM B 8131 [Austrian standard]
- Indoor chimneys: Requirements for planning and design, DIN 18160
- Dimensioning of chimneys, DIN 4705,  NORM M7515 [Austrian standard]
- Heating system water: preventing damage by corrosion and scale formation in hot-water heating systems, VDI 2035

**The regulations valid for the respective location of installation must always be complied with.**

We will be glad to give you the sources on request for the standards and regulations cited. If on stock, we will be glad to send these to you at cost price.

### **3 The structural surroundings of the burner**

Existing national building ordinances in this connection must always be complied with.

#### **3.1 Heating room requirements**

A separate heating room (the floor of which should be fire-resistant) must always be provided for the *PYROMAT ECO* solid fuel boiler.

The minimum distances to the walls and the ceiling required according to the table of dimensions for proper cleaning and maintenance of the boiler have to be complied with. A sufficient supply of fresh air has to be provided directly from outdoors into the heating room. Induced ventilation is required for heating rooms that are small and/or internally situated.

The temperature in the heating room must not exceed +40° C while the system is in operation (boiler surroundings approx. 1 m away from the boiler).

The temperature in the heating room must not fall below +10° C while the system is in operation (interior side of the outside wall).

#### **3.2 The chimney connection**

*PYROMAT ECO* solid fuel boilers are equipped with an exhaust gas fan and thus constitute a fire site not requiring a draught.

The design of the chimney should be carried out as for a fireplace with an oil or gas blast burner not requiring a draft (temperature of exhaust gas at nominal load: 160°-200° C). An insulated chimney should be provided to prevent the danger of sooting.

The path from the exhaust blower to the chimney should be as short as possible. 90° bends should be avoided if possible. Exhaust gas lines with lengths longer than 1 m should be insulated.

The connection to the chimney should be carried out in a fashion rising at an angle of 30°-45°. The exhaust gas line, incl. the lead-in into the chimney should be designed so as to be gas-tight.

### **4 The water installations**

Here we refer to the standards and regulations cited in this document.

#### **4.1 The safety equipment**

The safety equipping for the heating installation should be carried out by the installing heating engineer authorised to do so.

As examples, see spec sheets:  
2960-1 Installation, Closed System  
2960-2 Installation, Closed System  
2960-3 Installation, Open System  
2960-4 Installation, Open System

#### **4.2 Expansion**

The water volume enlarged by the storage units (option) requires a correspondingly large expansion tank.

For closed expansion, the set pressure for the expansion tank should be equal to the max. facility height plus 0.2 bar.

#### **4.3 The burner circuit with burner control valve and storage unit valve**

To reliably prevent burner corrosion through condensation of the exhaust gases, the burner temperature must in no case be less than 70° C. For this, a burner circuit pump should be provided with a boiler control valve according to the diagram (Spec Sheets 2960-1 to 2960-4). The design of the burner circuit should be carried out in such fashion that the temperature difference between forward flow and reverse flow is equal to or less than 15° C.

The triggering of the burner pump (230 V), burner control valve and storage unit valve is integrated in the control system that comes with the equipment.

## **5 The electrical installations**

### **5.1 The positioning of the control module and control system module**

The installing electrical firm should mount the control module at a place easily accessible for operation. By positioning the control system module near the heating distributor, the lengths of the lines can be minimised, thus reducing costs.

The position for the control system components has to be selected such that any negative influences by heat radiation (rear side of burner with exhaust gas collector and exhaust gas blower as well as exhaust gas line) or interference caused by dust during cleaning are as little as possible.

The ambient temperature (approx. 10 cm away) for the control system components during operation of the facility must not exceed 35° C. If there is any doubt, place the control system components outside the heating room near the door to the heating room.

### **5.2 Electrical connection**

- Connect it according to the wiring plan, laying of the CAN-BUS wire according to data sheet 4020.
- Around hot elements (exhaust gas blower, exhaust gas pipe), the lines should be installed so as to be temperature-protected in steel pipes at the distance necessary.
- The cable bushings to the motors and equipment should be designed so as to be dustproof and strain-relieved.

**The regulations of the local electric supply company must be complied with.**

For the position and description of the motors and sensors, see spec sheets.

## **6 Fire protection**

The fire protection regulations for wood heating systems vary for each specific country.

**The regulations valid for the respective place of installation must be complied with.**

### **6.1 Fire protection for the fuel storage space**

The measures necessary for this are never part of the scope of performance from Köb Holzheizsysteme GmbH.

**The conditions set by the local building authorities must be met by the operating organisation in this connection.**

## **7 Initial Start-up**

The initial start-up of a newly installed facility may only be carried out by Köb Holzheizsysteme GmbH or another specialist cited and trained by it. Before putting it into operation, the facility must be filled with water as per 7.1, fuel must be put in as per 7.2, and the installation has to be checked in accordance with 7.3.

### **7.1 Filling the heating system**

The first filling is usually done with untreated water without any chemical water treatment but definitely filtered and thus free of any suspended matter.

Be sure to carefully bleed out any air when the filling is done. With difficult water conditions (high degree of hardness, etc) and/or large water volumes, follow VDI Guideline 2035 "Preventing Damage by Corrosion and Scaling in Hot Water Heating Systems" by taking necessary measures to treat the water.

**Be very sure to note our General Terms and Conditions of Delivery.**

**Note: The filling pressure of the cold water reserve should be approx. 0.1 bar times greater than the set pressure of the closed expansion container.**

### **7.2 The fuel for the initial start-up**

For starting up operation, dry fuel (max. w 20%) must be put in amounting to at least two boiler fillings.

### 7.3 Inspecting the installation

Before the initial start-up, the future operating organisation must inspect the installation with the installing firm (installing heating engineer, electrician) for the following points:

1. Exhaust gas connection piece connected to the exhaust gas line to the chimney.
2. Chimney completely installed with clear cross-sectional area all the way through.
3. Safety valve mounted on burner and/or burner inlet.
4. Thermal run-off safety valve connected to the cold water mains.
5. The sensor for the thermal run-off safety valve is in the dipping shell.
6. The expansion tank is connected according to instructions (see spec sheets).
7. The facility has been filled with water.
8. Combustible fuel has been provided in the storage unit for the trial operation.
9. The control system is connected to the electric mains.
10. The motors, switches and sensors are all connected electrically.

**Do not put the facility into operation over-hastily without the presence of a specialist from Köb Holzheizsysteme GmbH or another specialist cited and trained by it. In case of damage you would lose your warranty claims.**

Inspected on .....

By .....

Signature .....

### 7.4 Initial start-up and handover

A competent contact person from the operating organisation's side has to be continuously present for the initial start-up and handover.

The positively carried out inspection of the installation has to be confirmed by the installing heating engineer by handing over these signed Installation Instructions.

By following these Installation Instructions and thereafter the Operating Instruction, you will be provided with heat from wood in a safe, reliable and convenient fashion.

Köb Holzheizsysteme GmbH thanks you for your trust shown.

**These Installation Instructions should be kept at the facility on a permanent basis.**

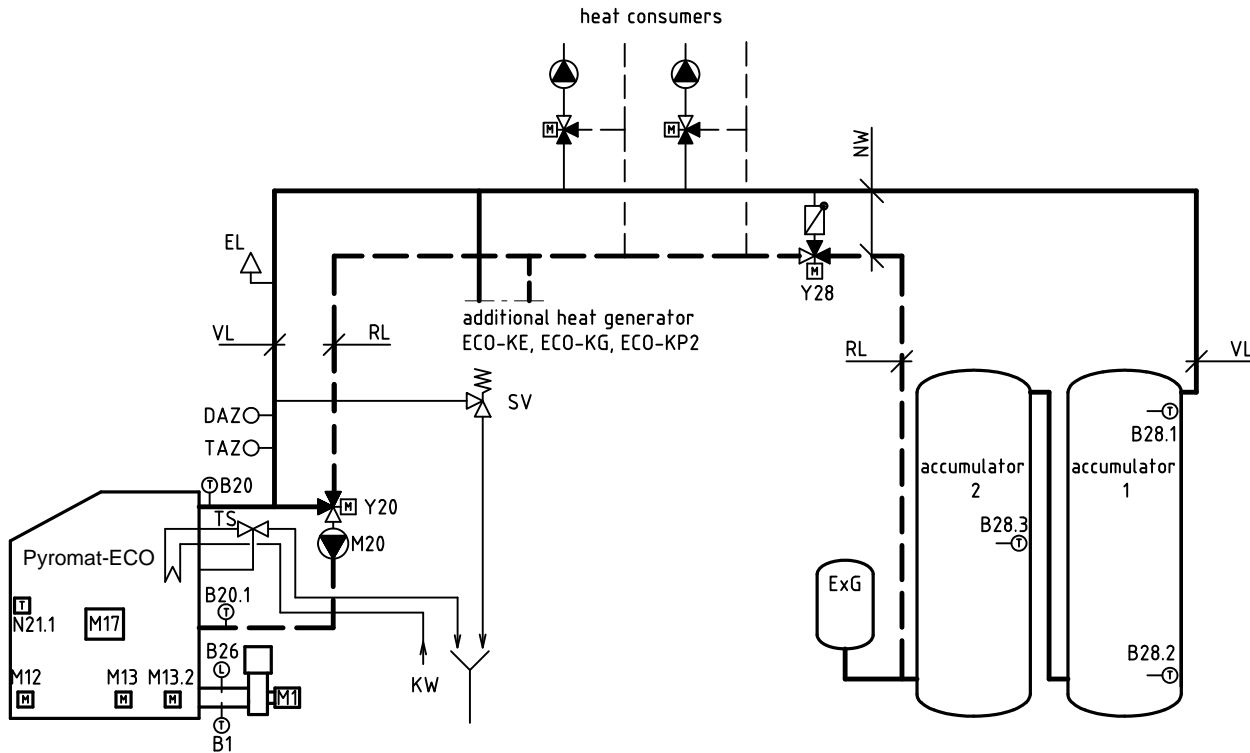

**Note:**

- To reliably prevent burner corrosion caused by condensation of exhaust gases, the burner return flow temperature must not by any means be below 65°C. To do so, a burner circuit pump should be provided with a burner control valve as per the diagram. The burner circuit should be configured such that the temperature difference between the forward and return flow is equal to or less than 15°C.  
 This is given in the design below, if no additional resistors are installed in the burner/accumulator circuit. Any installation of slide valves or of a heat meter will require reconfiguration of the burner pump and burner control valve by the heating technician.
- For incorporation of heat consumers or additional heat generators, refer to Spec Sheets 4000ff.
- The expansion tank has to be connected to the boiler above the boiler forward flow and without any shut-offs.

**a) Designation of the motors, sensors & safety switches**

Motors:

- M1 Exhaust fan
- M12 Primary air vent
- M13 Secondary air vent
- M13.2 Secondary air vent 2
- M17 Oil burner
- M20 Burner circuit pump
- Y20 Burner control valve
- Y28 Storage control valve

Electric sensors and safety switches:

- B1 Exhaust gas sensor PT-100
- B20 Burner sensor KTY
- B20.1 Return flow sensor KTY
- B26 Lambda sensor
- B28.1 Heat storage sensor, top KTY
- B28.2 Heat storage sensor, centre KTY
- B28.3 Heat storage control sensor, bottom KTY
- N21.1 Temperature-limiting safety switch

**b) Safety equipment provided by the installing heating engineer**

- SV... Safety valve, pressure set max. 3.0 bar, homologated component as per DIN 3440
- TS... Nominal width of the valve for the connecting line and the exhaust pipe as per DIN 4751, Part 2
- TS... Thermal run-off safety valve R 3/4", homologated component, opening temperature 95°-100°C, (safety heat exchanger built into the burner)
- KW... Cold water inlet DN 15 R 1/2", metal, fixed pipework, min. 2.5 bar, max. 3.5 bar, exhaust pipe R 3/4";
- EL... Air separator (recommended: absorption-type degasser)
- ExG... Expansion tank closed, homologated
- DAZ... Manometer
- TAZ... Thermometer



**c) Burner circuit with storage circuit and closed expansion / Recommended configuration**

Boiler PYROMAT-ECO	Burner circuit pump (M20) Make: Wilo Model	Burner control valve (Y20) Make: Siemens Model	Storage control valve (Y28) Make: Siemens Model	Forward flow (VL) Return flow (RL)
30/5, 35, 45	EAS 30/6-3-PR-180-12-I	VXG 48.32/SQS 35	VXG 48.40/SQS 35	NW 40
55, 65	TOP-S 30/7 EM	VXG 48.32/SQS 35	VXG 48.40/SQS 35	NW 40
75, 85, 61, 81	TOP-S 30/7 EM	VXG 48.40/SQS 35	VXG 48.40/SQS 35	NW 50
101, 151	TOP-S 40/7 EM	VXG 48.40/SQS 35	VBF 21.50/SQK 33	NW 50

1) Or equivalent

**d) Dimensioning of buffer storage unit as per EN 303-5**

Minimum storage volume for exemplary acceptance of  $Q_H$   
with  $T_B \times Q_N$  for beechwood, dry

PYROMAT-ECO Model	Rated output $Q_{min} - Q_N$ (kW)	Min. $V_{SP}$ (l)	$T_B \times Q_N$ (kWh)	$Q_H$ (kW)
30/5	25 – 30	2169	179	16
35	35 – 40	2156	179	23
45	38 – 50	2091	179	28
55	45 – 60	2890	247	33
65	55 – 75	2876	247	41
75	60 – 80	3405	291	44
85	75 – 95	3440	291	53
61	60 – 85	4193	363	46
81	75 – 100	4247	363	55
101	90 – 130	5675	485	66
151	120 – 170	5784	485	82

$V_{SP}$  Volume of buffer storage unit in  
litres  
 $Q_N$  Nominal heat output in kW  
 $T_B$  Burn-out period in h  
 $Q_H$  Heating requirements for the  
building in kW  
 $Q_{min}$  Lowest heat output in kW

$$V_{SP} = 15 \cdot T_B \cdot Q_N \cdot \left( 1 - 0,3 \frac{Q_H}{Q_{min}} \right)$$

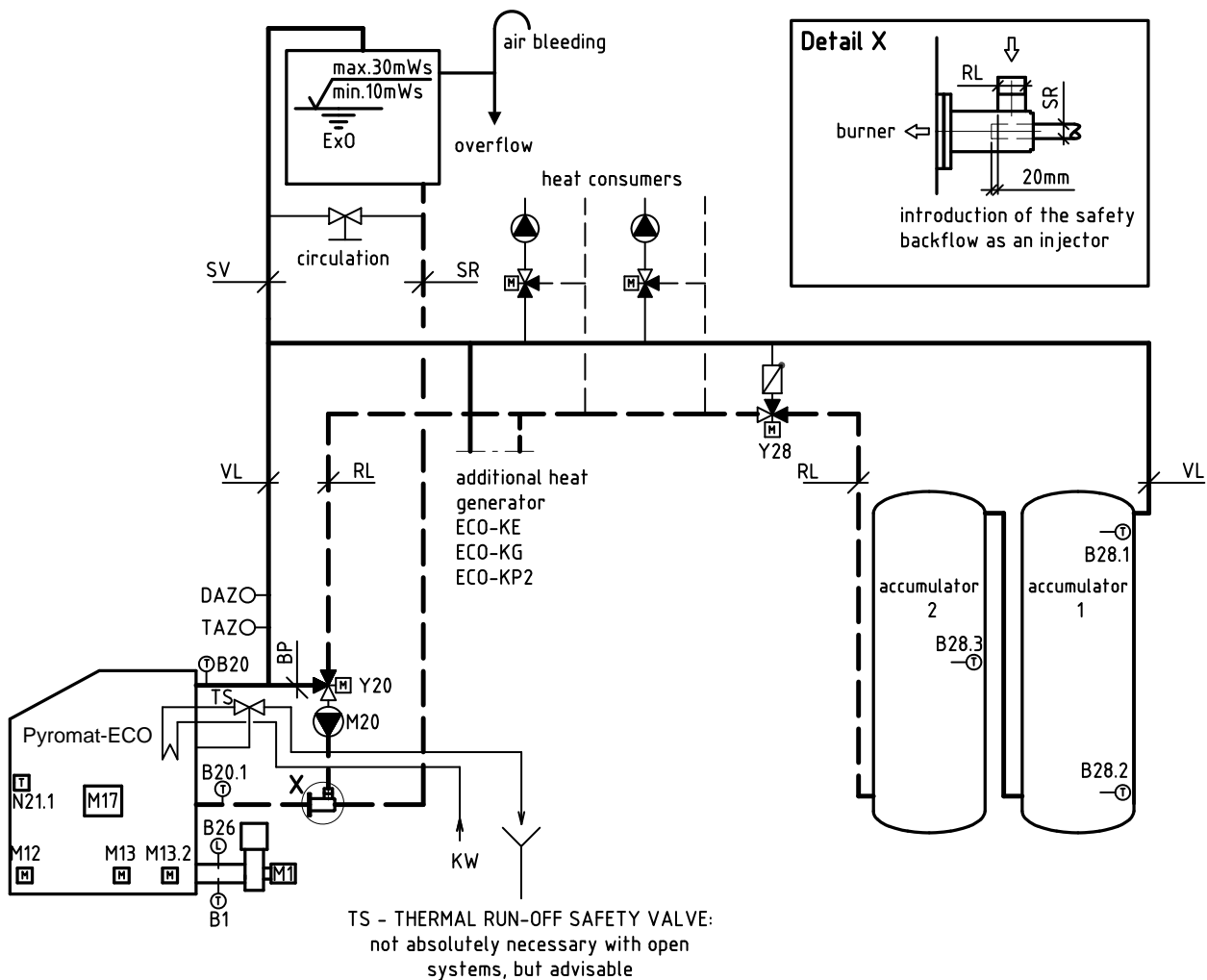

**Note:**

- To reliably prevent burner corrosion caused by condensation of exhaust gases, the burner return flow temperature must not by any means be below 65°C. To do so, a burner circuit pump should be provided with a burner control valve as per the diagram. The burner circuit should be configured such that the temperature difference between the forward and return flow is equal to or less than 15°C. This is given in the design below, if no additional resistors are installed in the burner/accumulator circuit. Any installation of slide valves or of a heat meter will require reconfiguration of the burner pump and burner control valve by the heating technician.
- For incorporation of heat consumers or additional heat generators, refer to Spec Sheets 4000ff.
- The expansion tank has to be connected to the boiler above the boiler forward flow and without any shut-offs.

**a) Designation of the motors, sensors & safety switches**

**Motors:**

- M1 Exhaust fan
- M12 Primary air vent
- M13 Secondary air vent
- M13.2 Secondary air vent 2
- M17 Oil burner
- M20 Burner circuit pump
- Y20 Burner control valve
- Y28 Storage control valve

**Electric sensors and safety switches:**

- B1 Exhaust gas sensor PT-100
- B20 Burner sensor KTY
- B20.1 Return flow sensor KTY
- B26 Lambda sensor
- B28.1 Heat storage sensor, top KTY
- B28.2 Heat storage sensor, centre KTY
- B28.3 Heat storage sensor, bottom KTY
- N21.1 Temperature-limiting safety switch

**b) Safety equipment provided by the installing heating engineer**

- TS... Thermal run-off safety valve R ¾", homologated component, opening temperature 95°-100°C, (safety heat exchanger built into the burner)
- KW... Cold water inlet DN 15 R ½", metal, fixed pipework, min. 2.5 bar, max. 3.5 bar, exhaust pipe R ¾";
- ExO... Expansion tank, open, heat insulated on the highest point of the system;
- DAZ... Manometer
- TAZ... Thermometer

**c) Burner circuit with storage circuit and open expansion / Recommended configuration**

Boiler PYROMAT-ECO	Burner circuit pump (M20) Make: Wilo Model	Burner control valve (Y20) Make: Siemens Model	Storage control valve (Y28) Make: Siemens Model	Forward flow (VL) Return flow (RL)
30/5, 35, 45	EAS 30/6-3-PR-180-12-I	VXG 48.32/SQS 35	VXG 48.40/SQS 35	NW 40
55, 65	TOP-S 30/7 EM	VXG 48.32/SQS 35	VXG 48.40/SQS 35	NW 40
75, 85, 61, 81	TOP-S 30/7 EM	VXG 48.40/SQS 35	VXG 48.40/SQS 35	NW 50
101, 151	TOP-S 40/7 EM	VXG 48.40/SQS 35	VBF 21.50/SQK 33	NW 50

1) Or equivalent

**d) Dimensioning of buffer storage unit as per EN 303-5**

Minimum storage volume for exemplary acceptance of  $Q_H$   
with  $T_B \times Q_N$  for beechwood, dry

PYROMAT-ECO Model	Rated output $Q_{min} - Q_N$ (kW)	Min. $V_{SP}$ (l)	$T_B \times Q_N$ (kWh)	$Q_H$ (kW)
30/5	25 – 30	2169	179	16
35	35 – 40	2156	179	23
45	38 – 50	2091	179	28
55	45 – 60	2890	247	33
65	55 – 75	2876	247	41
75	60 – 80	3405	291	44
85	75 – 95	3440	291	53
61	60 – 85	4193	363	46
81	75 – 100	4247	363	55
101	90 – 130	5675	485	66
151	120 – 170	5784	485	82

- $V_{SP}$  Volume of buffer storage unit in litres
- $Q_N$  Nominal heat output in kW
- $T_B$  Burn-out period in h
- $Q_H$  Heating requirements for the building in kW
- $Q_{min}$  Lowest heat output in kW

$$V_{SP} = 15 \cdot T_B \cdot Q_N \cdot \left( 1 - 0,3 \frac{Q_H}{Q_{min}} \right)$$

**Thermic safety outlet 100°C** [Art.-No. K-TS-131 / 7387405]

Standard design for fixed response temperature approx. 100°C, R ¾" connection

Scope of delivery:

- Thermic safety outlet, incl. dipping shell

*Note: We also always recommend the K-TS-131 even when the local regulations do not make it mandatory.*

**Thermic safety outlet 50-120° C** [Art.-No. K-TS-140 / 7387406]

Special design for response temperature set to 120° C, R ¾" connection

Scope of delivery:

- Thermic safety outlet, incl. dipping shell

*Note: Spare for Art. No. K-TS-131; use only with manufacturer's declaration*

**Thermal Extinguishing Valve ½", 50-90°C** [Art. No. K-SLV / 7388521]

This is a thermally opening extinguishing valve with adjustable opening temperature for connection by customers to a pressurised water line or an extinguisher water container.

Scope of delivery:

- Extinguishing valve (Danfoss AVTA), adjustable 50-90° with dirt trap

**Automatic Fire-extinguishing System** [Art. No. K-SLE / 7387785]

In the event of any burn-back, the Thermal Extinguishing Valve will open and reliably prevent it with a limited amount of water.

Location: On the feed auger

Scope of delivery:

- Extinguishing valve (Danfoss AVTA), adjustable 50-90° with dirt trap
- Extinguishing water container, 25 litres with holding device and level-monitoring system (level float switch)

*Note: We recommend the K-SLE for the PYROMAT-DYN for burning remnant wood left over from wood processing.*

*Not required by the fire-prevention regulations for pellets and smaller fuel depots!*

*This equipment is included with PYROT and PYRTEC boiler systems.*

*Please observe local fire-prevention provisions!*

**Motor-2-port valve,... [Art.-No. ZV-...]**

These Siemens valves (models VVG and VXG) are characterised by precise control behaviour and leak-tight closing without leakage losses. An important criterion for quality, especially for the PYROMAT burner series with accumulator operation.

**Motor-three way tap,... [Art.-No. ZH-3-...]**

[Art. No.]	Structural design	Model	DN [mm]	Kvs [m <sup>3</sup> /h]	Adjusting drive 230 V	Incl. complete bolted connection
ZV-2-20 / 7388232	2-port valve	VVG 48.20	20	6.3	SSY 319	R ¾" – G 1¼"
ZV-2-25 / 7387483	2-port valve	VVG 48.25	25	10	SSY 319	R 1" – G 1½"
ZV-2-32 / 7388259	2-port valve	VVG 48.32	32	16	SQS 35.00	R 1¼" – G 2"
ZV-2-40 / 7388166	2-port valve	VVG 48.40	40	20	SQS 35.00	R 1½" – G 2¼"
ZV-3-20 / 7388152	3-port valve	VXG 48.20	20	6.3	SSY 319	R ¾" – G 1¼"
ZV-3-25 / 7387484	3-port valve	VXG 48.25	25	10	SSY 319	R 1" – G 1½"
ZV-3-32 / 7388049	3-port valve	VXG 48.32	32	16	SQS 35.00	R 1¼" – G 2"
ZV-3-40 / 7388204	3-port valve	VXG 48.40	40	20	SQS 35.00	R 1½" – G 2¼"
ZH-3-50 / 7388100	3-way tap	VBF 21.50	50	40	SQK 33	Counter-flange, seals
ZH-3-65 / 7388160	3-way tap	VBF 21.65	65	63	SQL 33	Counter-flange, seals
ZH-3-80 / 7388260	3-way tap	VBF 21.80	80	100	SQL 33	Counter-flange, seals
ZH-3-100 / 7388165	3-way tap	VBF 21.100	100	160	SQL 33	Counter-flange, seals
ZH-3-125 / 7388053	3-way tap	VBF 21.125	125	550	SQL 33	Counter-flange, seals

**Pump ... [Art.-No. ZP-...]**

[Art. No.]	Pump model <sup>1)</sup>	DN [mm]	Voltage [V]	Capacity [W]	Capacity [m <sup>3</sup> /h/mWS]	Incl. complete bolted connection	RPM-controlled
ZPS-255 7388095	RS 25/6	25	230	46-93	2.5/6.5	R 1" – G 1½"	-
ZPE-256 7388057	Stratos ECO 25/1,5	25	230	5.8-59	2.5/5.0	R 1" – G 1½"	X
ZPS-258 7388162	TOP-S 25/7 EM	25	230	95-195	7.5/7.0	R 1" – G 1½"	-
ZPS-325 7388244	TOP-S 30/7 EM	32	230	85-195	7.5/7.0	R 1¼" – G 2"	-
ZPE-258 7388075	TOP-S 25/7 DM	25	400	65-200	7.5/7.0	R 1¼" – G 2"	-
ZPS-326 7388216	RS 30/6	32	230	46-93	2.5/6.5	R 1¼" – G 2"	-
ZPS-406 7388114	TOP-S 40/7 EM	40	230	220-390	16.5/7.0	Counter-flange, seals	-
ZPS-406-4 7388108	TOP-S 40/7 DM	40	400	130-370	16.5/7.0	Counter-flange, seals	-
ZPS-506-4 7388271	TOP-S 50/7 DM	50	400	245-625	28.0/7.0	Counter-flange, seals	-
ZPS-656-4 7388221	TOP-S 65/10 DM	65	400	400-960	42.0/9.0	Counter-flange, seals	-
ZPS-806-4 7388224	TOP-S 80/7 DM	80	400	320-880	30/4.5	Counter-flange, seals	-
ZPS-8012-4 7388131	TOP-S 80/10 DM	80	400	710-1500	30/6.0	Counter-flange, seals	-
ZPS-1060-4 7388202	IL 100/145-1,1/4	100	400	1100	40/5.7	Counter-flange, seals	-

<sup>1)</sup> Choice of the pump manufacturer and pump type remains a reservation of our purchasing department or the engineering department, Viessmann.

*Note: No individual deliveries of Z.. products! Z.. products are only delivered together with an entire system.*

**Wall-mounted Manifold 65-2** [Art.-No. LVW-65-2 / 7387823]  
**Wall-mounted Manifold 65-3** [Art.-No. LVW-65-3 / 7388040]

Wall-mounted heat distributor; forward- and return-flow distributor packed with intermediate insulation (chamber size 55 mm x 55 mm); distributor insulated all around and covered with powder coated steel plates.

Special design for Siemens motor-operated valves, models VXG 25/ SSY 319 (Art. No: ZV-3-25 / 7387484). Especially suited for the Pyromat burner series with accumulator operation (burner output up to 65 kW).

- Connections: Burner: Forward flow/return flow: 1½" IG on the left or right side  
 Accumulator: Forward flow/return flow: 1½" IG on the left or right side  
 Consumer: Forward flow/return flow: 1" AG at top with bypass, for two or three groups (last digit of the Art. No.)  
 Incl. bolted connection for motor-operated valves, Siemens models VXG 25/ SSY 319 (Art. No: ZV-3-25 / 7387484).

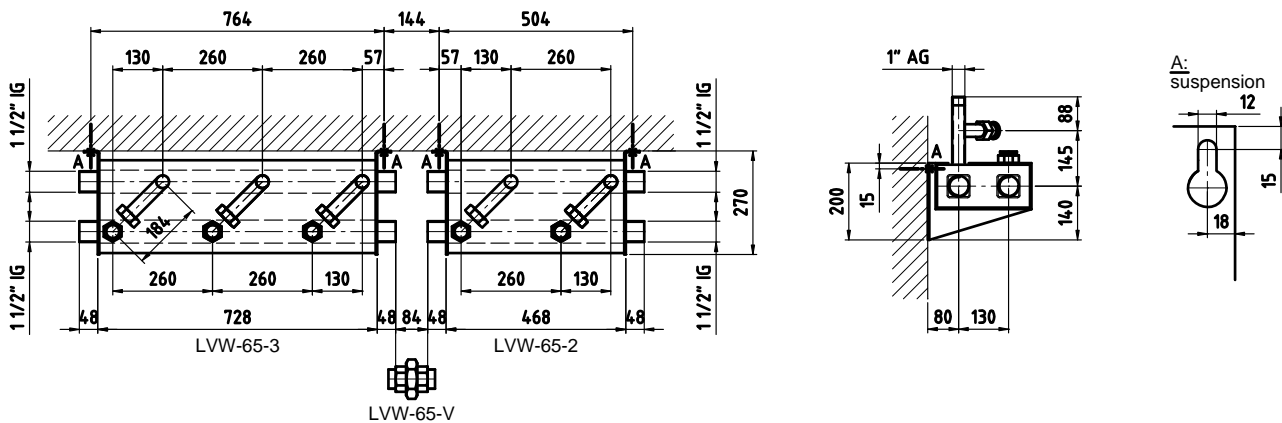

**Heat Distributor Connection LVW-65** [Art. No. LVW-65-V / 7387862]

Connecting two model LVW-65- manifolds produces a manifold for four to six consumer groups. The connection is assembled at the factory to assure an accurate fit.

**Heat Distributor for Burner Design 65-2** [Art. No. LVK-65-2 / 7387815]  
**Heat Distributor for Burner Design 65-2** [Art. No. LVK-65-2 / 7387947]

Heat distributor for burner design; forward- and return-flow distributor packed with intermediate insulation (chamber size: 55 mm x 55 mm); distributor insulated all around and covered with powder-coated steel plates.

Special design for Siemens motor-operated valves, models VXG 25/ SSY 319 (Art. No: ZV-3-25 / 7387484). Especially suited for the PYROMAT burner series with accumulator operation (burner output up to 65 kW).

- Connections: Boiler: Forward flow/return flow 1 1/2 " IG on the left side  
 Accumulator: Forward flow/return flow 1 1/2 " IG on the left side  
 Consumer: Forward flow/return flow: 1" AG at top with bypass, for two or three groups (last digit of the Art. No.)  
 Incl. bolted connection for motor-operated valves, Siemens models VXG 25/ SSY 319 (Art. No: ZV-3-25 / 7387484).

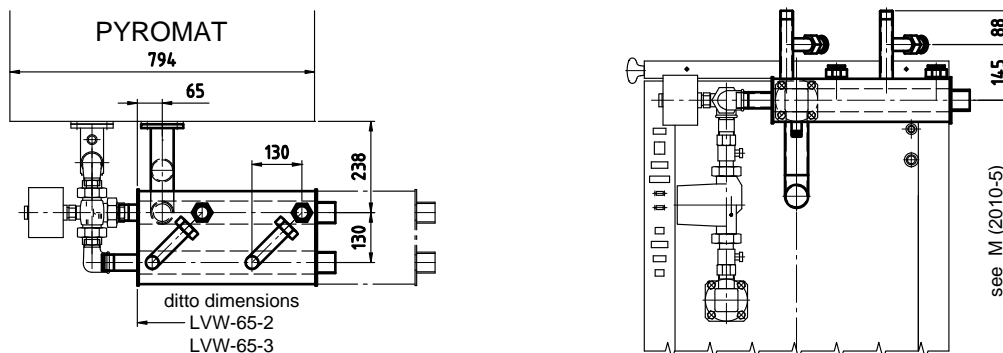

**Note:** This burner design is not possible with PYROMAT-DYN - standard version, hydraulically switched heat storage tank

**Heating Group for Heat Distributor NW 25 [Art. No. LH-25 / 7387988]**

A heating group for mounting on manifold models LVW and LVK, without pump, consisting of:

- Motor valve, Siemens VXG 48.25/SSY 319 for precise control behaviour and leak-free closing without leakage losses
- One ball valve with screwed connection for mounting on motor valve VXG 48.25/SSY 319, with pump connection on bottom
- One ball valve with thermometer socket and screwed connection with pump connection on top
- One ball valve with thermometer socket, screwed connection and fastener for return flow
- Two immersion thermometers, installation in ball valve (forward- and return-flow)

Heating pump with L 180, 1" connection: provided by the customer or as per Spec Sheet 4600-1  
(Art.-No. ZPS-25\_ or ZPE-25\_)

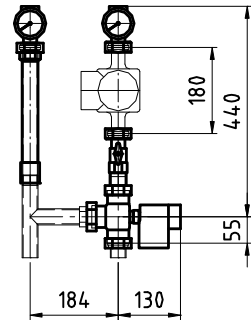

*Note: If a heater group's valve is to be used as quantity control (2-port valve for ECO-B1, -B2), the union on the bypass must be sealed with a closed sealing disc.*

**The burner:**

This beautifully designed burner makes operation very easy when heating with logs and remnant wood, and it also allows an oil burner to be connected. Filling is done conveniently from the top, and the burn-out happens at the bottom. The re-incineration is carried out in optimum fashion in a patented combustion chamber made of refractory concrete. The supply of combustion air (primary and secondary airflow) is cleverly controlled as a function of the lambda sensor and the temperature of the exhaust gas. The surplus heat produced is conducted into the accumulators with precise stratification.

Equipped with an absolutely silent and long-lasting exhaust fan, the burner is of high quality and solidly constructed. Maximum burner efficiency rates along with clever usage of residual heat in the burner guarantee maximum convenience and minimum fuel requirements.

The burner group, the exhaust fan, incl. the exhaust gas sensor and the lambda sensor are all wired to the burner in plug-and-play fashion, making installation especially simple. The individual parts can be easily detached for service purposes later on.

Max. flow temperature:	100°C
Max. operating pressure:	3.0 bar
Test pressure:	5.0 bar
Safety heat exchanger:	Built-in & ready for use

**Pre-installed burner group**

The burner group is pre-installed on the connecting flange. It is made up of the burner pump, burner control valve, and the forward and return flow sensors, incl. fittings. The pump is built in between two shut-off devices.

**The plug-and-play ECOTRONIC for a burner system with storage management:**

The ECOTRONIC control system is a decentralised microprocessor system (CAN-bus). To regulate the burner system with storage management, the ECOTRONIC consists of a module integrated in the burner and the control module. The control module (300 mm wide x 280 mm high x 100 mm deep) mounts on the wall where possible and is connected to the burner via a data transmission line in plug-and-play fashion.

**Functions:**

- Output control system with storage management provided by continuously adjusting air vents, optimising heat-ups and burn-outs

Nominal load: during accumulator loading phase

Partial load: at the end of the accumulator loading phase

- An additional control circuit with a lambda sensor provides for perfect incineration and maximum efficiency rates.
- Keeping up the return temperature by means of the burner control valve provides for a long service life of the burner.
- During the start-up phase the complete heat output is available to the consumers (no diversion of heat into the accumulator via the return flow)
- Exact temperature stratification of the accumulator using the storage control valve enables long-lasting heat
- The primary air vent closes while wood is being reloaded to provide for safe reloading of wood
- Heat remaining in the boiler after burn-outs is completely exploited
- Help and service functions provide support
- Control of an additional oil burner on the PYROMAT
- The best possible protection against overheating is guaranteed by diverting heat to accumulators, disconnecting the exhaust gas fan and closing the air vents.

**Scope of delivery:**

- Burner with integrated electronic module, incl. temperature-limiting safety switch; plug-and-play exhaust gas fan with exhaust gas sensor and lambda sensor; ash drawers; stoking and cleaning device;
- Flanged on burner group with burner pump, burner control valve, forward and return flow sensors
- Storage control valve (uninstalled)
- Control module (300 mm wide, 280 mm high x 100 mm deep): display with background lighting and comprehensive display of text; simple, clearly laid out pushbutton operation for PYROMAT-ECO burner system
- Five pushbuttons for operating external controllers
- Three KTY heat accumulator sensors, incl. dipping shell (1/2" x 280 mm long) wired together to plug

**Note:**

- *Regarding data cable for connection to the control module (separate price item), see Spec Sheet 4020*



**Schematic diagram with ECOTRONIC**

**ECOTRONIC with heating regulator units:**

The ECOTRONIC can be expanded by a great number of heating control units (heat consumers, auxiliary heat generators) (refer to spec sheets, Category 4).

The operation of the external controllers is all carried out in the control module for the burner system.

Each controller is operated by a separate pushbutton.

The ECOTRONIC can be extended as follows:

- 1) Economical solution for small-scale systems with:  
 Control module for external control systems [Art. No. ECO-BM00]  
 Maximum of three controllers (see spec sheets, Category 4)
  
- 2) Ready-made solution for complex systems with  
 Control system module (Art. No. ECO-RM00)  
 With additional control system modules, up to 13 controllers can be integrated in the in ECOTRONIC  
 (refer to spec sheets, Category 4)

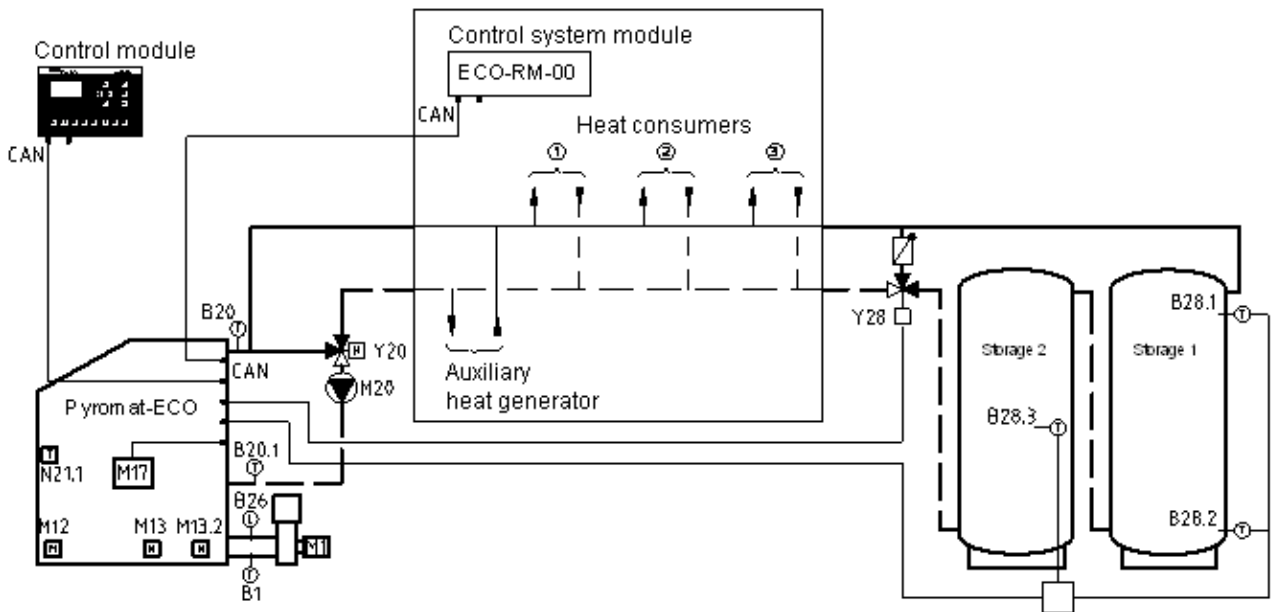

Heat accumulators Refer to Spec Sheets 4700  
 Domestic water heaters: Refer to Spec Sheets 4750

**PYROMAT-ECO with integrated manifold**

One manifold with two or three consumer groups can be integrated with the PYROMAT-ECO burner.

In this design with the manifold attached, the boiler forms a compact overall system (refer to Spec Sheets 4600).

**Technical data:**

Trade name	Boiler PYROMAT-ECO..									
	35	45	55	65	75	85	61	81	101	151
Art. No.:	KPM-ECO-35 7387412	KPM-ECO-45 7387797	KPM-ECO-55 7387838	KPM-ECO-65 7387968	KPM-ECO-75 7388007	KPM-ECO-85 7387844	KPM-ECO-61 7387413	KPM-ECO-81 7387805	KPM-ECO-101 7388024	KPM-ECO-151 7387779
Nominal heat output [kW]	40	50	60	75	80	95	85	100	120	170
Minimum heat consumption, wood [kW]	35	38	45	55	60	75	60	75	90	110
Max. log length [m]	1/2	1/2	1/2	1/2	1/2	1/2	1	1	1	1
Firebox volume [l]	185	185	255	255	255	255	375	375	500	500
Boiler water volume [l]	130	130	170	170	210	210	230	230	300	300
Boiler weight without water [kg]	750	760	920	935	1040	1065	1300	1320	1680	1720
Test pressure [bar]	6	6	6	6	6	6	6	6	6	6
Max. operating pressure [bar]	3	3	3	3	3	3	3	3	3	3
Max. boiler temperature, wood [°C]	100	100	100	100	100	100	100	100	100	100
Min. return temperature [°C]	70	70	70	70	70	70	70	70	70	70
Resistance on water-bearing side (Diff. 10 K) [mbar]	32	32	62	62	98	98	56	56	112	112
Resistance on water-bearing side (Diff. 20 K) [mbar]	8	8	16	16	25	25	14	14	28	28
Thermal run-off safety valve: min. flow rate at 2.5 bar [kg/h]	2000	2000	2800	2800	3500	3500	3500	3500	5500	5500
Boiler efficiency nominal heat output wood [%]	87-92	87-92	87-92	87-92	87-92	97-92	87-92	87-92	87-92	87-92
Exhaust gas temperature, nominal heat output, wood [°C]	180	180	180	180	180	180	180	180	180	180
Exhaust gas mass flow nominal heat output wood [g/s]	30.4	35.2	44	56	60	68	58.4	72	88	108
Max. flue draught, wood [Pa] 1)	25	25	25	25	25	25	25	25	25	25
Nominal heat output, oil [kW]	35	38	45	55	60	75	60	75	90	110
Boiler efficiency Nominal heat output, oil [%]	87-92	87-92	87-92	87-92	87-92	97-92	87-92	87-92	87-92	87-92
Exhaust gas temperature Nominal heat output, oil [°C]	168	168	168	168	170	170	172	172	168	168
Chimney draught required [Pa] 2)	+-0	+-0	+-0	+-0	+-0	+-0	+-0	+-0	+-0	+-0
Electrical power, exhaust fan [kW]	0.08	0.08	0.08	0.08	0.15	0.15	0.15	0.15	0.25	0.25
<b>Burner group</b>										
Burner pump, Wilo model	RS 30/6		TOP-S 30/7		TOP-S 30/7			TOP-S 40/7		
Electrical power for pump [W]	46-93		85-195		85-195			220-390		
Pump output m³/h at mWS	2.5 at 6.5		7.5 at 7.0		7.5 at 7.0			16.5 at 7.0		
Burner control valve, Siemens model	VXG 48.32		VXG 48.32		VXG 48.40			VXG 48.40		
Drive for burner control valve, Siemens	SQS 35.00		SQS 35.00		SQS 35.00			SQS 35.00		
Weight of burner group [kg]	14		16		20			40		
Storage control valve, Siemens model	VXG 48.40		VXG 48.40		VXG 48.40			VBF 21.50		
Drive for storage control valve	SQS 35.00		SQS 35.00		SQS 35.00			SQK 33		
Weight of storage control valve [kg]	2.5		2.5		2.5			6.9		

1) Maximum overpressure during the start-up phase (chimney cold) in the exhaust pipe after the exhaust fan

2) Do not install a chimney draught controller!

**Dimensional drawing:**

View from the front

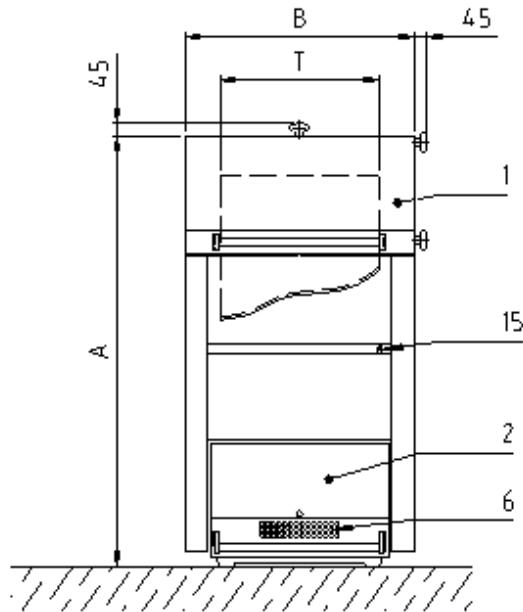

View from the rear

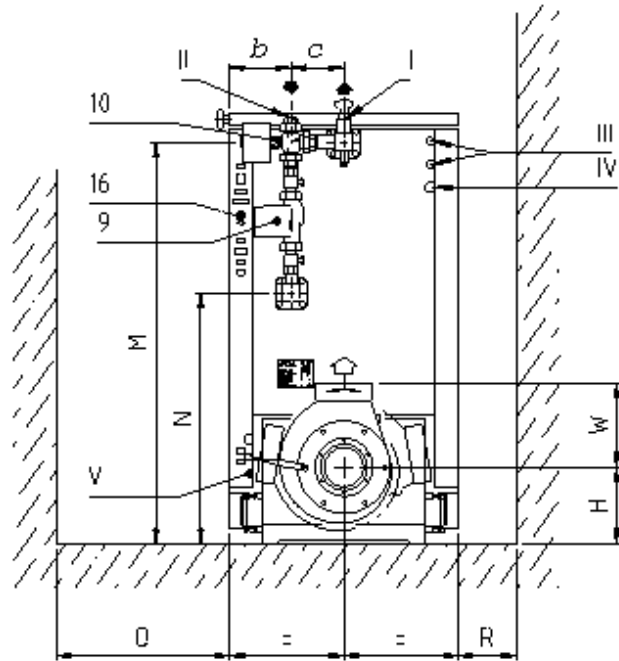

**Table of dimensions:**

Boiler PYROMAT-ECO [Art.-No.]		KPM-ECO-35 738741 2	KPM-ECO-45 738779 7	KPM-ECO-55 738783 8	KPM-ECO-65 738796 8	KPM-ECO-75 738800 7	KPM-ECO-85 738784 4	KPM-ECO-61 738741 3	KPM-ECO-81 738780 5	KPM-ECO-101 738802 4	KPM-ECO-151 738779
Connections:											
I	Forward flow, connection Bsp	R 1¼"	R 1¼"	R 1¼"	R 1¼"	R 1½"	R 1½"	R 1½"	R 1½"	R 1½"	R 1½"
II	Return flow, connection Bsp	R 1¼"	R 1¼"	R 1¼"	R 1¼"	R 1½"	R 1½"	R 1½"	R 1½"	R 1½"	R 1½"
III	Safety valve Bsp connection	R ½"	R ½"	R ½"	R ½"	R ½"	R ½"	R ½"	R ½"	R ½"	R ½"
IV	Sensor for run-off safety valve Bsp connection	R ½"	R ½"	R ½"	R ½"	R ½"	R ½"	R ½"	R ½"	R ½"	R ½"
V	Drain valve	R ½"	R ½"	R ½"	R ½"	R ½"	R ½"	R ½"	R ½"	R ½"	R ½"
VI	Sight glass (transport hook) connection Bsp	R 1"	R 1"	R 1"	R 1"	R 1"	R 1"	R 1"	R 1"	R 1"	R 1"
Dimensions [mm]:											
A	Height of casing	1433	1433	1490	1490	1490	1490	1433	1433	1490	1490
B	Width of casing (dismantled)	795 (686)	795 (686)	795 (686)	795 (686)	795 (686)	795 (686)	1324 (1246)	1324 (1246)	1324 (1246)	1324 (1246)
C	Length of casing	958	958	1163	1163	1313	1313	1018	1018	1353	1353
D	Length of exhaust blower	500	500	500	500	630	630	630	630	630	630
E	Filling height	1134	1134	1134	1134	1134	1134	1134	1134	1134	1134
F	Height of lid, open	1892	1892	2012	2012	2012	2012	1892	1892	2012	2012
G	Radius of ash door	365	365	365	365	365	365	365	365	365	365
H	Outlet, boiler	265	265	265	265	265	265	265	265	265	265
J	Outlet, exhaust blower	175	175	175	175	300	300	300	300	300	300
K	Flange of oil burner	647	647	769	769	842	842	631	631	820	820
L	Flange of oil burner	770	770	773	773	813	813	770	770	876	876
M	Flange, forward flow, boiler	1331	1331	1389	1389	1386	1386	1328	1328	1386	1386
N	Flange, return flow, boiler	811	811	869	869	693	693	635	635	636	636
O	Space for operation	800	800	800	800	800	800	800	800	800	800
P	Min. distance to wall	100	100	100	100	100	100	100	100	100	100
Q	Space for cleaning	600	600	600	600	600	600	800	800	800	800
R	Min. distance to wall	200	200	200	200	200	200	400	400	400	400
S	Connection for exhaust blower. 1)	200	200	200	200	200	200	200	200	250	250
T	Width of firebox	550	550	550	550	550	550	1080	1080	1080	1080
U	Depth of firebox	300	300	400	400	475	475	300	300	400	400
W	Outlet, exhaust blower	293	293	293	293	293	293	293	293	293	293
Y	Width of handle	45	45	45	45	45	45	45	45	45	45
a	Connection, boiler	108	108	108	108	108	108	108	108	108	108
b	Connection, boiler	214	214	214	214	214	214	480	480	480	480
c	Connection, boiler	183	183	183	183	183	183	183	183	183	183
Operation and maintenance											
1	Firebox door										
2	Ash pan door										
3	Cleaning door, top										
4	Cleaning door, bottom										
5	Flange for attaching the burner slide-out system, maintenance cover to combustion chamber (on both sides)										
Electric drives											
6	Primary air vent with servomotor										
7	Secondary air vent with servomotor										
8	Motor for exhaust blower										
9	Burner pump										
10	Burner control valve with servomotor										
Electric connections and sensors											
11	Burner sensor										
12	Return circuit sensor										
13	Exhaust gas sensor										
14	Lambda sensor										
15	Burner control panel with temperature-limiting safety switch (TLSS)										
16	Sockets for electrical connection										

1) Reduction is possible to KPM-ECO-65 (160 mm or 180 mm)

**Reducer for Exhaust Gas Connection 180 [Art. No. KPM-RD-180 / 7387892]  
Reducer for Exhaust Gas Connection 160 [Art. No. KPM-RD-160 / 7387961]**

This reduces exhaust gas connection from D 200 mm to D 180 mm or 160 mm (plug-in extension by 100 mm).

*Note: Only for burner systems Pyromat 35, 45, 55 & 65*

**Exhaust blower-intake port 90° left [Art.-No. KPM-RG-90-L / 7387871]  
Exhaust blower-intake port 90° right [Art.-No. KPM-RG-90-R / 7387970]**

exhaust fan aligned to the left

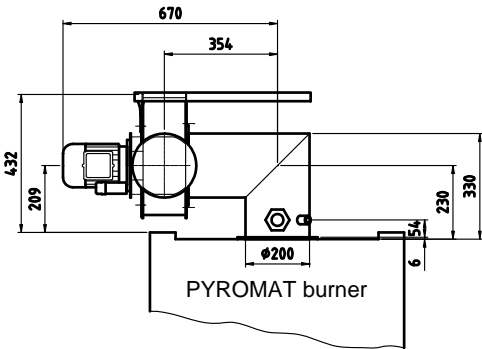

exhaust fan aligned to the right

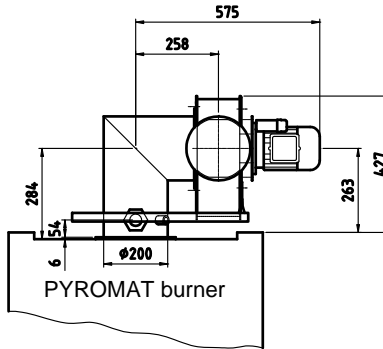

**Exhaust gas de-duster Pyromat 35-75 [Art. No. KPM-RE-70 / 7387875]  
Exhaust gas de-duster Pyromat 81-151 [Art. No. KPM-RE-150 / 7387926]**

An axial cyclone de-duster that attaches to the exhaust gas port of the Pyromat boiler. The ashes are removed at the bottom from the side. The de-duster is insulated and cased in powder-coated steel plate.

When operated according to the operating instructions, dust emissions, even when chips are incinerated, are under 150 mg/Nm<sup>3</sup> based on 13% residual oxygen.

Exhaust blower: The exhaust blower mounts onto the de-duster and has greater dimensions in comparison with the normal design.

*Note: Due to increased loss of pressure, burner operation on the Pyromat (ECO) may, depending on the exhaust design, only be possible with reduced burner output.*

[Art. No.]	KPM-RE-70 7387875		KPM-RE-150 7387926	
For burner KPM-ECO	35/45	55/65	81/85	151
Exhaust blower [kW]	0.08	0.15	0.25	0.37
A	450		450	
B	1161		1411	
C	190		190	
D	320		320	
E	1671		1921	
G	200		200	
H	265		265	
J	740		520/770*	
K	177		205	
L	454		520	
M	364		410	
N	293		293	
S	200		200/250*	
Weight [kg]	74		95	

\* Only for Pyromat-ECO 101/151

*Note: An exhaust gas de-duster is necessary when chips and fine particles are regularly included in the fuelling (wood-processing businesses).*

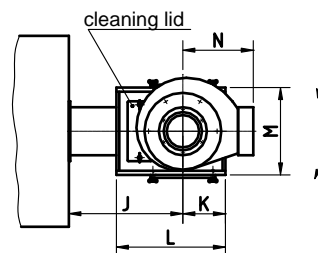
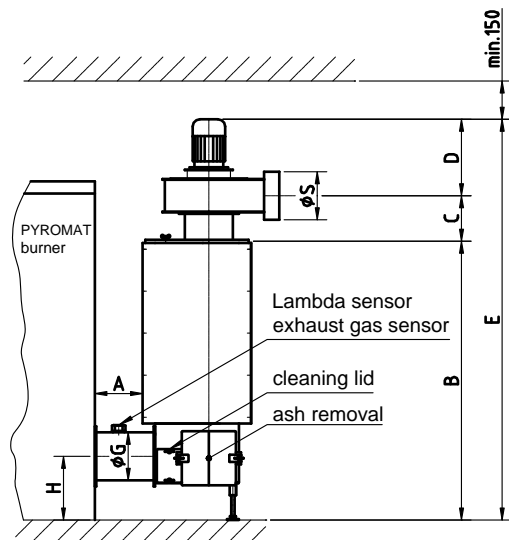

**Burner Slide-out System [Art. No. KPM-E-OBA / 7387410]**

For left- or right-hand side installation on the PYROMAT; manual retraction of the burner against spring pressure; when pulled out, a weighted shutter closes automatically, thus protecting the burner from soiling; protected by a limit switch.

Flange diameter, inside: 128 mm  
 Hole circle diameter: 150 mm  
 Retracting stroke: 160  
 Weight without burner: 24 kg

Scope of delivery:

- 1 limit switch mounted on slide-out system
- 1 limit switch uninstalled, for installation by the customer on filler lid

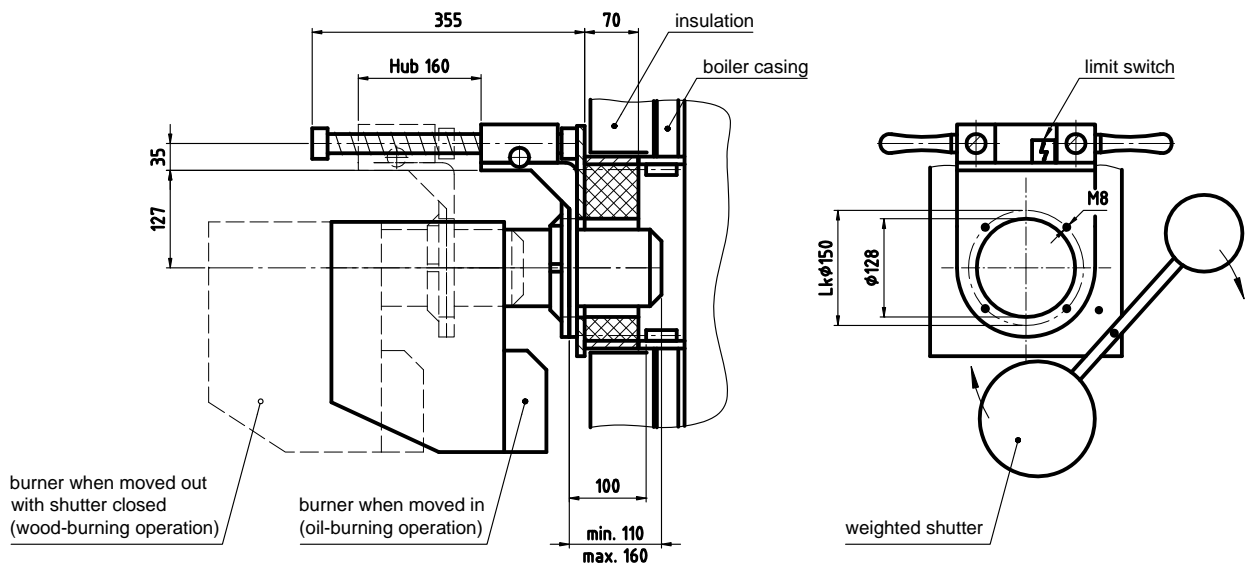

**Controllers possible in the Ecotronic for PYROMAT-ECO, PYROMAT-DYN and PYROT**

Type of controller	Designation	Art. No.	Push-buttons	Number of controllers	Number of sensors	Spec Sheet
Controllers for additional heat generators	Heat generator, single	ECO-KE	1	1	-	4030
	Heat generator, gliding	ECO-KG	1	1	1	4030
	Heat generator, parallel	ECO-KP0	1	2	-	4030
	Heat generator, parallel 1	ECO-KP1	1	2	1	4030
	Heat generator, parallel 2	ECO-KP2	1	2	1	4030
	Accumulator management system, 5 sensors (QM)	ECO-KSF5	1	1	2	6800
Controllers for room heating units	Room heating	ECO-H	1	1	1	4040
	Annex buildings	ECO-N	1	2	2	4040
	Pipelining	ECO-F	1	1	1	4040
	Air handling unit group	ECO-L	1	1	1	4040
	Thermostat for ECO-H, N	ECO-ZR-QA	-	-	1	4040
	Safety thermostat ECO-H, N, F	ECO-ZR-RA	-	-	-	4040
Controllers for domestic water	Domestic Water Heater (without quantity control system)	ECO-B1	1	1	1	4040
	Domestic Water Heater (with quantity control system)	ECO-B2	1	1	2	4040
	Domestic water circulation system	ECO-BZ	1	1	-	4040
Controllers for solar systems	Solar domestic water heater	ECO-S1	1	1	2	4050
	Solar domestic water heating system	ECO-S3	1	2	2	4050

**Modules and combinations possible (see Spec Sheet 4020):**

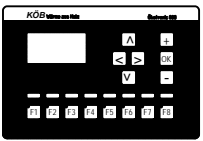
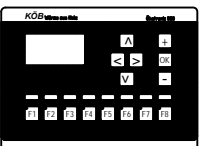
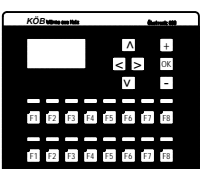
Extra charge for control system module Extra charge for control module	Without control system module	1 Control System Module 1 x ECO-RM00 7379403	2 Control System Modules 2 x ECO-RM00 7379403	3 Control System Modules 3 x ECO-RM00 7379403
 Control module Standard 4 (5*) Control buttons	Standard without extra charge. No heating control unit is possible.	A maximum of 4 controllers and 7 sensors are possible.	A maximum of 4 (5)* controllers and 14 sensors are possible.	
 Control module with extended control system Art. No. ECO-BM-00 / 7387957 4 (5*) Control buttons	A maximum of 3 controllers and 3 sensors are possible.	Extended control system in the control module and control system module A maximum of 4 (5)* controllers and 10 sensors are possible.		
 Control module with extended keyboard Art. No. ECO-13 / 7387820 12 (13*) control buttons		A maximum of 4 controllers and 7 sensors are possible.	2 Control System Modules A maximum of 8 controllers and 14 sensors are possible.	3 Control System Modules A maximum of 12 (13)* controllers and 21 sensors are possible.

**With regard to visualisation, remote maintenance and data archiving, refer to Spec Sheet 4090**

**Control Module with Extended Control System [Art. No. ECO-BM00 / 7387957]**

The ECOTRONIC is a decentral microprocessor system where different modules can be connected to one another with one data line (CAN-BUS). A limited number of controllers (2-3 units) can be inexpensively integrated in the control module.

Scope of delivery:

- Control module in compact design instead of standard design
- Weather sensor QAC 31, uninstalled

**Control system module [Art. No. ECO-RM00 / 7379403]**

A control system module to accommodate external controllers (for heat consumers/additional heat generators). The control buttons are integrated in the control module.

Scope of delivery:

- Control System Module in plastic casing (length: 325 mm; height: 195 mm; depth 75 mm)
- Weather sensor QAC 31, uninstalled

**Control Module with Extended Keyboard [Art. No. ECO-13 / 7387820]**

A control module with an additional row of buttons to operate a maximum of: 12 controllers (PYROMAT-DYN, PYROT)  
 13 controllers (Pyromat-ECO)

**Data transmission line with plug, 10.0 m standard [Art. No. ECO-ZL-10,0 / 7387587]**

**Data transmission line with plug, 2.0 m [Art. No. ECO-ZL-2,0 / 7387858]**

**Data transmission line with plug, 5.0 m [Art. No. ECO-ZL-2,0 / 7388000]**

**Data transmission line with plug, 20.0 m [Art. No. ECO-ZL-2,0 / 7388025]**

**Data transmission line with plug, 40.0 m [Art. No. ECO-ZL-2,0 / 7387588]**

**Data transmission line with plug, 80.0 m [Art. No. ECO-ZL-2,0 / 7387972]**

**Data line with Y distributor [Art.-Nr. ECO-ZY-0,5 / 7387948]**

The data transmission line connects the various modules (burner module, control module & control system module) to the overall facility control system. The data transmission lines can be connected to one another (maximum of two lines).

Note:

The sum of all CAN bus lines must not exceed 200 m.

**Example of how to connect the CAN-BUS cables for the PYROMAT-ECO:**

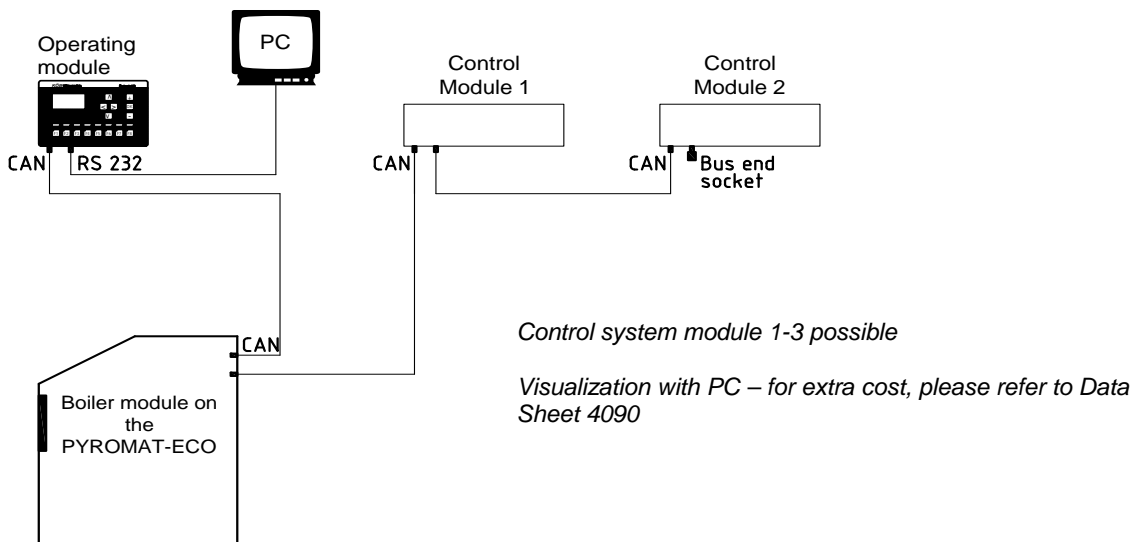



**Example of how to connect the CAN-BUS cables for the PYROMAT-DYN:**

**Version 1: Control module in the heating room**

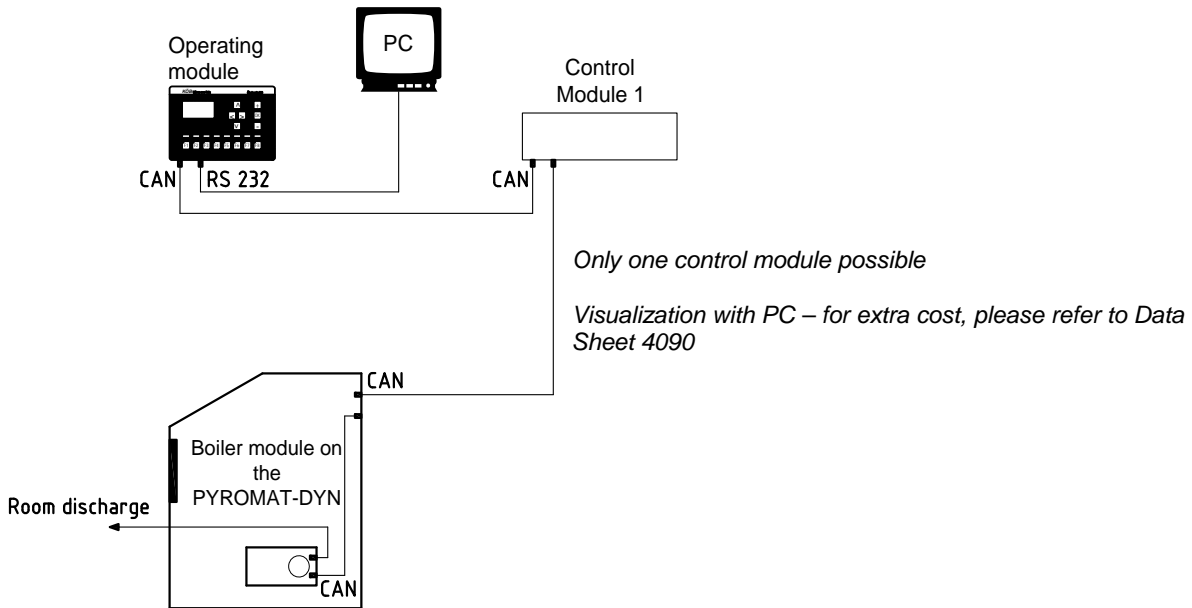

**Version 2: Decentral control system module (e.g. in annex building)**

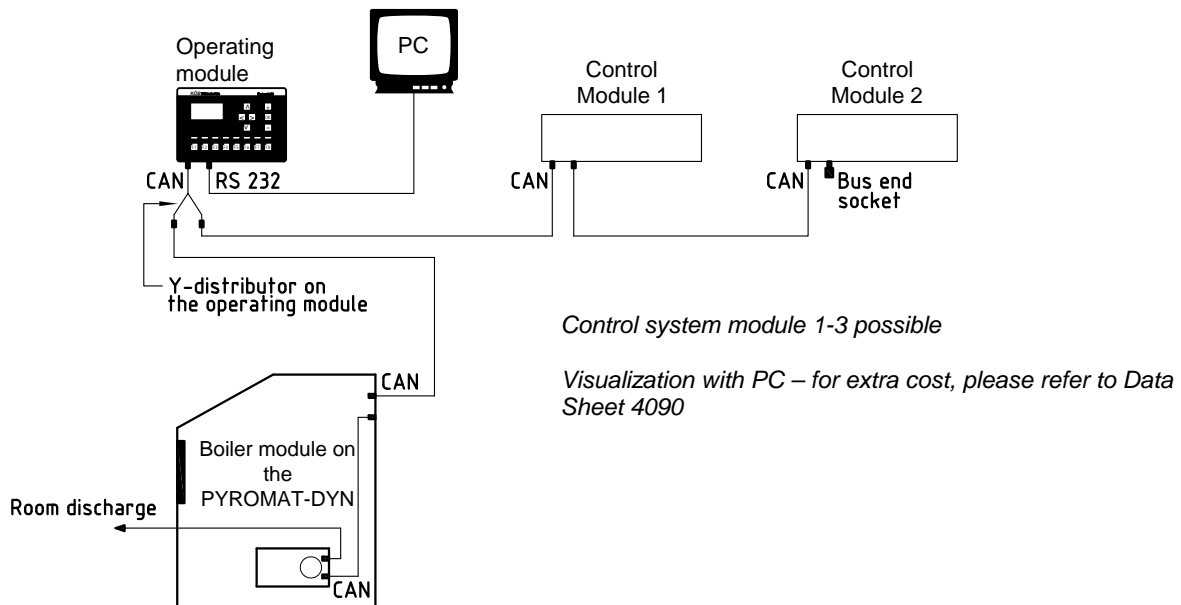

**Example of how to connect the CAN-BUS cables for the PYROT:**

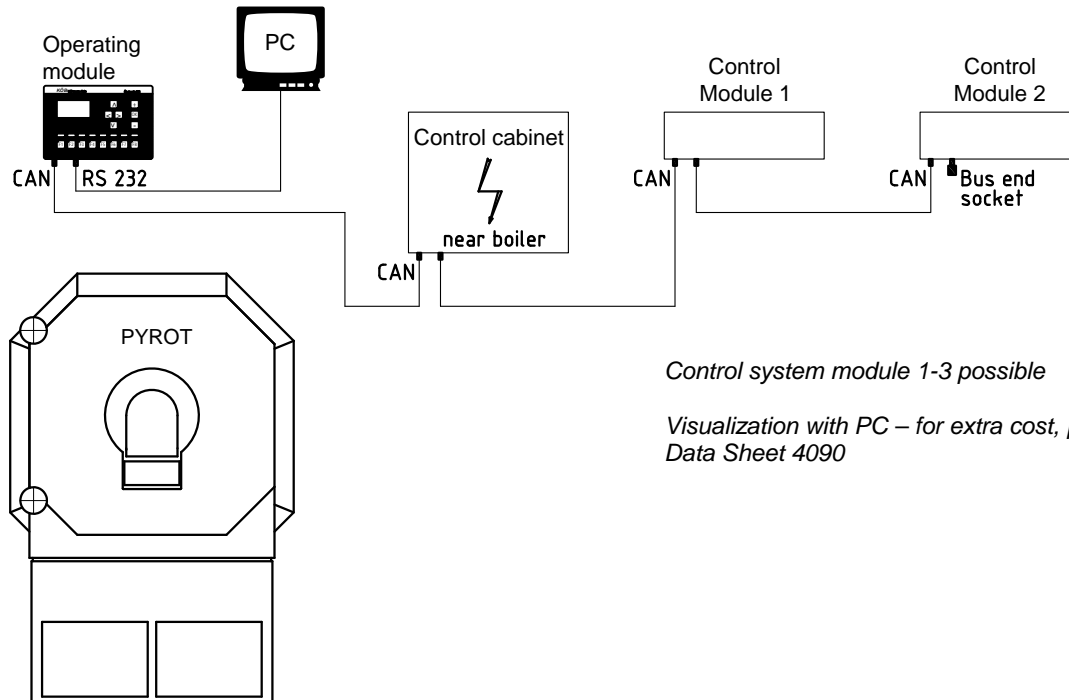

*Control system module 1-3 possible*

*Visualization with PC – for extra cost, please refer to Data Sheet 4090*

**Description:**

**Controller for Heat Generator, single [Art. No. ECO-KE / 7388036]**

Immediately after heat is taken from the accumulator to cover a heat requirement (stand-alone operation), an additional heat generator is automatically connected. Loading of the storage accumulator can only be loaded using the PYROMAT. When it is put into operation, the additional heat generator disconnects, and the closed shut-off valve prevents it from being flowed through.

Scope of delivery:

- Pushbuttons for additional heat generators
- Controller output for shut-off valve (2) and burner (3)

*Note: Only for PYROMAT-ECO and PYROMAT-DYN with ECO function.  
See Hydraulic Drawing 2960 PYROMAT-ECO or 3950 PYROMAT-DYN with ECO function.*

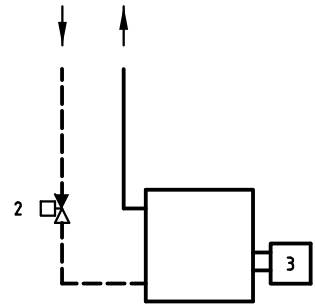

**Controller for Heat Generator, single, gliding [Art. No. ECO-KG / 7387859]**

Immediately after heat is taken from the accumulator to cover a heat requirement (stand-alone operation), an additional heat generator is automatically connected. Loading of the storage accumulator can only be loaded using the PYROMAT. When it is put into operation, the additional heat generator disconnects, and the closed shut-off valve prevents it from being flowed through. The boiler temperature is variably regulated to a minimum temperature according to the heat requirement.

Scope of delivery:

- Pushbuttons for additional heat generators
- Controller output for shut-off valve (2) and burner (3)
- Flow sensor QAD 21, uninstalled

*Note: Only for PYROMAT-ECO and PYROMAT-DYN with ECO function.  
See Hydraulic Drawing 2960 PYROMAT-ECO or 3950 PYROMAT-DYN with ECO function.*

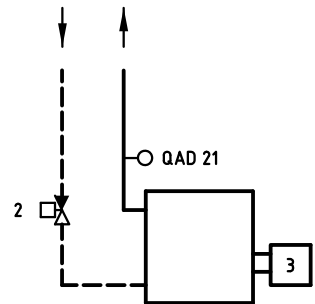

**Controller for Heat Generator, parallel KP2 [Art. No. ECO-KP2 / 7387864]**

When required, an additional heat generator is automatically connected. This may occur after heat is taken from the accumulator to cover the overall heat requirement heat requirement (stand-alone operation). Or the additional heat generator may be used to cover a peak requirement for heat (parallel operation to the biomass boiler). For parallel operation, a burner group is necessary for heat diversion, which simultaneously also provides for keeping up the return flow. On request, the additional heat generator can load the accumulator (as desired to B28.1, B28.2 or B28.3).

Scope of delivery:

- Pushbuttons for additional heat generators
- Controller output for pump (1), mixing valve (2) and burner (3)
- Return flow sensor QAD 21, uninstalled

*Note: Only for PYROMAT-ECO and PYROMAT-DYN with ECO function.  
See Hydraulic Drawing 2960 PYROMAT-ECO or 3950 PYROMAT-DYN with ECO function.*

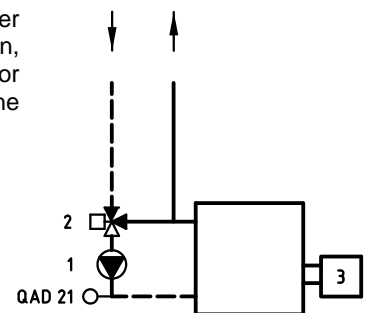

**Description:**

**Controller for Heat Generator, parallel KP0 [Art. No. ECO-KP0 / 7387923]**

Either individually or together with the biomass boiler, the auxiliary heat generator supplies the heat accumulator, executed as a hydraulic switcher. The triggering is carried out such that the additional heat generator covers the peak required, and the biomass boiler does so for the base load, the sluggishness of the biomass boiler being taken into account. While the additional heat generator is in the operational phase, the boiler pump is in operation and the motor-driven shut-off device open.

Scope of delivery:

- Button for additional heat generator
- Contactor and motor contactor for the boiler pump for the additional heat generator
- Controller output for pump (1), mixing valve (2) and burner (3)

*Note: Only for PYROMAT-DYN without ECO function and PYROT with hydraulic switcher.  
See Hydraulic Drawing 3950 PYROMAT-ECO or 6960 PYROMAT-DYN with ECO function.*

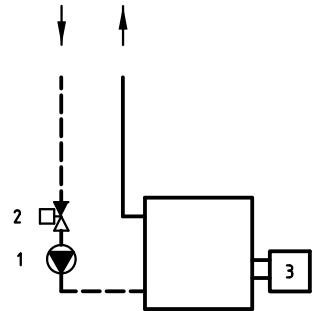

**Controller for Heat Generator, parallel KP1 [Art. No. ECO-KP1 / 7387908]**

When required, an additional heat generator is automatically connected. This may occur after heat is taken from the accumulator to cover the overall heat requirement (stand-alone operation). Or the additional heat generator may be used to cover a peak requirement for heat (parallel operation to the biomass boiler). For parallel operation, a burner group is necessary for heat diversion, which simultaneously also provides for keeping up the return flow. On request, the additional heat generator can load the accumulator (as desired to B28.1, B28.2 or B28.3).

Scope of delivery:

- Pushbuttons for additional heat generators
- Controller output for pump (1), mixing valve (2) and burner (3)
- Return flow sensor QAD 21, uninstalled

*Note: Only for PYROMAT-DYN without ECO function and PYROT with hydraulic switcher.  
See Hydraulic Drawing 3950 PYROMAT-ECO or 6960 PYROMAT-DYN with ECO function.*

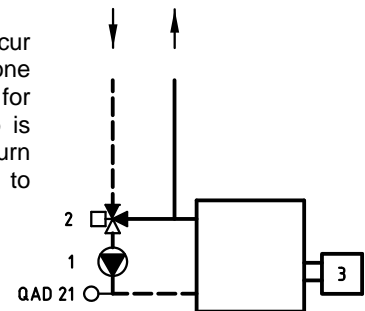

**Controller for Room Heating Units [Art. No. ECO-H / 7379402]**

A weather-guided heating control system with a digital timer for lowerable operation according to daily or weekly schedules, with pump control system, frost-protection function, ECO mode and limited flow temperature.

Scope of delivery:

- Pushbutton for heating
- Controller output for pump (1) and mixing valve (2)
- Flow sensor QAD 21, uninstalled

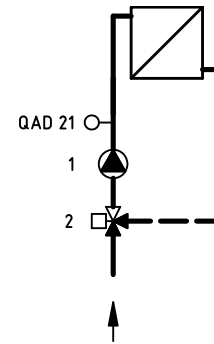

**Controller for Annex Buildings [Art. No. ECO-N / 7387865]**

Function:

The pipelining is usually loaded with a lowered temperature according to the weather-guided heating control system. The charging of the utility water heater is carried out with the maximum set supply temperature. To do this the hot water is diverted by a valve to the utility water heater. This is extended to ancillary time periods by the integrated timer, whereby the room unit will be interrupted for a short time.

Scope of delivery:

- Pushbutton for annex building
- Controller output for pump (1), mixing valve (1) and changeover valve (3)
- Flow sensor QAD 21, uninstalled
- Domestic water sensor QAZ 21.5220 with dipping shell 1/2" x 200 mm, uninstalled

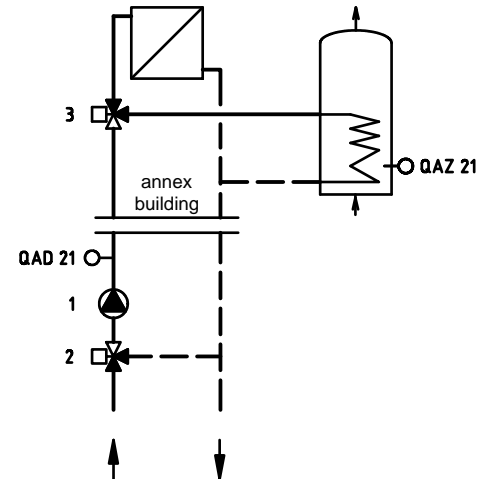

**Thermostat QAA 35 [Art. No. ECO-ZR-QA / 7379405]**

Thermostat QAA 35, uninstalled; a supplement to the Controller for Room Heating Units (Art. No. ECO-H) and Controller for Annex Buildings (Art. No. ECO-N). The Thermostat can be connected as a remote control device and as a room sensor (room temperature compensation).

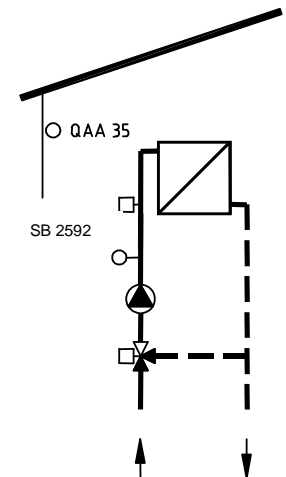

**Safety Thermostat RAK-TW.1000B [Art.-No. ECO-ZR-RA / 7387940]**

Safety Thermostat SB 2592, uninstalled

To safely and reliably limit the flow temperature of a heating circuit (e.g. ECO-H, ECO-N, ECO-F).

**Controller for Pipelining [Art. No. ECO-F / 7379401]**

For annex buildings with separate heat distributions systems, which are supplied with heat via pipelining. The temperature of the pipeline is pre-adjusted for the lowest line losses according to the heat distribution requirement.

Scope of delivery:

- Pushbutton for pipelining
- Controller output for pump (1) and control valve (2)
- Flow sensor QAD 21, uninstalled

Note:

*The Controller for Pipelining cannot be used to control a pipeline to which heating control units provided by the customer are connected!*

*A normal heating control system has to be used in such cases.*

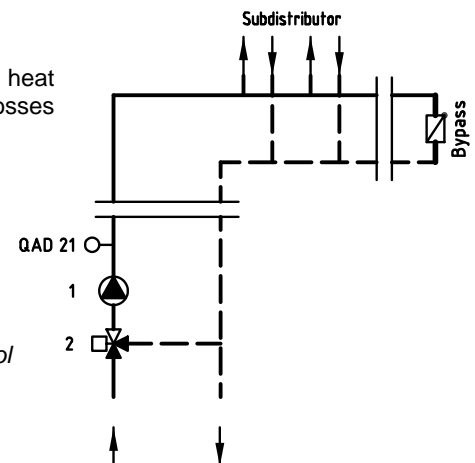

**Controller for Air Heater** [Art.-No. ECO-L / 7387825]

The boiler storage system supplies the air heaters with maximum flow temperature. The fans are switched by switches or controllers provided by the customer. The flow rate for the heating water is controlled by the return flow temperature and so adjusted to the heat output of the air heater (quantity control). This produces optimum storage stratification for a long time and at a high temperature at the accumulator flow pipe. The heating times (day and week program) can be adjusted via the integrated timer.

Scope of delivery:

- Pushbutton for air handling unit group
- Controller output for pump (1) and mixing valve (2)
- Return flow sensor QAD 21, uninstalled
- Baffle bypass

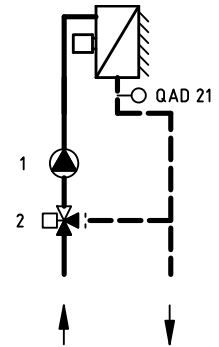

**Controller for Domestic Water Heater B1** [Art. No. ECO-B1 / 7387853]

If the utility water temperature drops then this is re-heated by the boiler or the heat storage via the integrated heat exchanger. An appropriate temperature differential (selectable between differential temperature or fixed preset temperature) is a prerequisite. The heating times (day and week program) can be adjusted via the integrated timer.

Scope of delivery:

- Pushbutton for domestic water heater
- Controller output for pump (1) and shut-off valve (2)
- Domestic water sensor QAZ 21.5220 with dipping shell, 1/2" x 200 mm, uninstalled

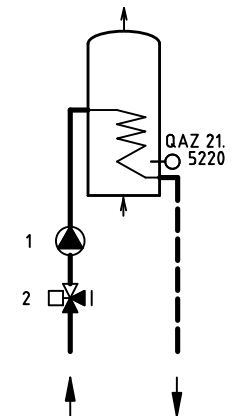

**Controller for Domestic Water Heater B2** [Art. No. ECO-B2 / 7379400]

If the utility water temperature drops then this is re-heated by the boiler or the heat storage via the integrated heat exchanger. An appropriate temperature differential (selectable between differential temperature or fixed preset temperature) is a prerequisite.

The hot water flow rate is controlled by the return temperature (flow control). This produces optimum storage stratification for a long time and at a high temperature at the accumulator flow pipe. The heating times (day and week program) can be adjusted via the integrated timer.

Scope of delivery:

- Pushbutton for domestic water heater
- Controller output for pump (1) and control valve (2)
- Return flow sensor QAD 21, uninstalled
- Domestic water sensor QAZ 21.5220 with dipping shell 1/2" x 200 mm, uninstalled

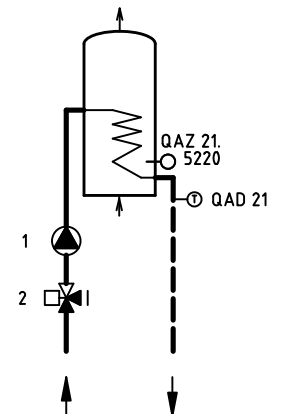

**Controller for Domestic Water Circulation System** [Art. No. ECO-BZ / 7387849]

An integrated timer can be used to set the circulation periods (daily and weekly schedules). The duration for the circulation pump to be switched on can be adjusted using a cyclical switching system.

Scope of delivery:

- Pushbutton for circulation system
- Controller output for pump (1)

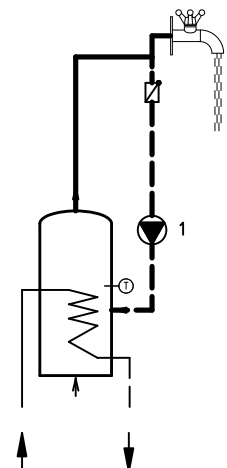

**Controller for Solar Domestic Water Heater [Art. No. ECO-S1 / 7387818]**

Application for simple solar systems as a single-circuit controller for heating the domestic water in the solar domestic water heater (Art. No.: WSS-...). The ECO-S1 controller is an add-on module for the ECO-B1 domestic water heater controller (2). If the solar collector is warmer than the domestic water below, the water is heated up by the solar collector (adjustable temperature difference 2–20° C).

Further details:

- Post-flow period of the solar pump, no/yes: 0-120 sec., adjustable according to length of line
- Maximum domestic water temperature (adjustable: 20-90°C)
- Safety: disconnection of the solar pump at a collector temperature of 140°C; reconnection at 120°C

Scope of delivery:

- Pushbutton for solar system
- Collector sensor PT-1000
- Domestic water sensor QAZ 21.5220
- Controller output for solar pump (1)

Note:

Only possible in combination with domestic water heater control (ECO-B1 or ECO-B2).

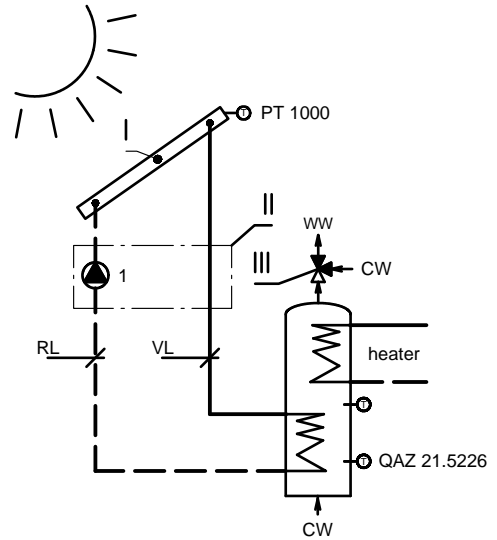

- I. solar collector
- II. solar station with solar pump
- III. thermostatic water mixer

**Solar/domestic water and heating controller [Art.-No. ECO-S3 / 7387786]**

For use in large-scale solar facilities to heat the domestic water in a solar domestic water heater (Art. No: WSS-...) and to supply heat to the heat accumulator in the form of a triple control circuit heating system. The first circuit is for heating the domestic water, the second circuit is for heating the heat accumulator at the back/bottom and the third circuit is for heating the heat accumulator at the front/top. The heat accumulator is heated by an externally situated plate heat exchanger. When there is a changeover from the domestic water heater to the heat accumulator, the secondary pump is switched on, which is then operated with the solar pump. For optimised functioning, the flow rate in the secondary circuit has to be adapted to the primary circuit (e.g. with flow rate gauges in the primary and secondary circuits).

The following temperature differences are freely adjustable:

Temperature difference of collector/domestic water: 2-20°C

Temperature difference of collector/accumulator, rear/bottom: 2-20°C

Further details:

- Post-flow period of the solar pump, no/yes: 0-120 sec., adjustable according to length of line
- Disconnection safeguard: At collector temperature of 140°C  
At accumulator temperature of 95°C
- Optimised domestic water priority (option of either absolute domestic water priority or none at all)
- Stratified accumulator loading according to the accumulator temperatures, via valve/accumulator, back/accumulator front (4)

Scope of delivery:

- Pushbutton for solar system
- Collector sensor PT-1000
- Domestic water sensor QAZ 21.5220
- Controller output for solar pump (1)
- Controller output for valve, domestic water heater/accumulator (2)
- Controller output for secondary pump (3)
- Controller output for valve, accumulator back/accumulator front (4)

Note:

Only possible in combination with domestic water heater control (ECO-B1 / 7387853 or ECO-B2 / 7379400).

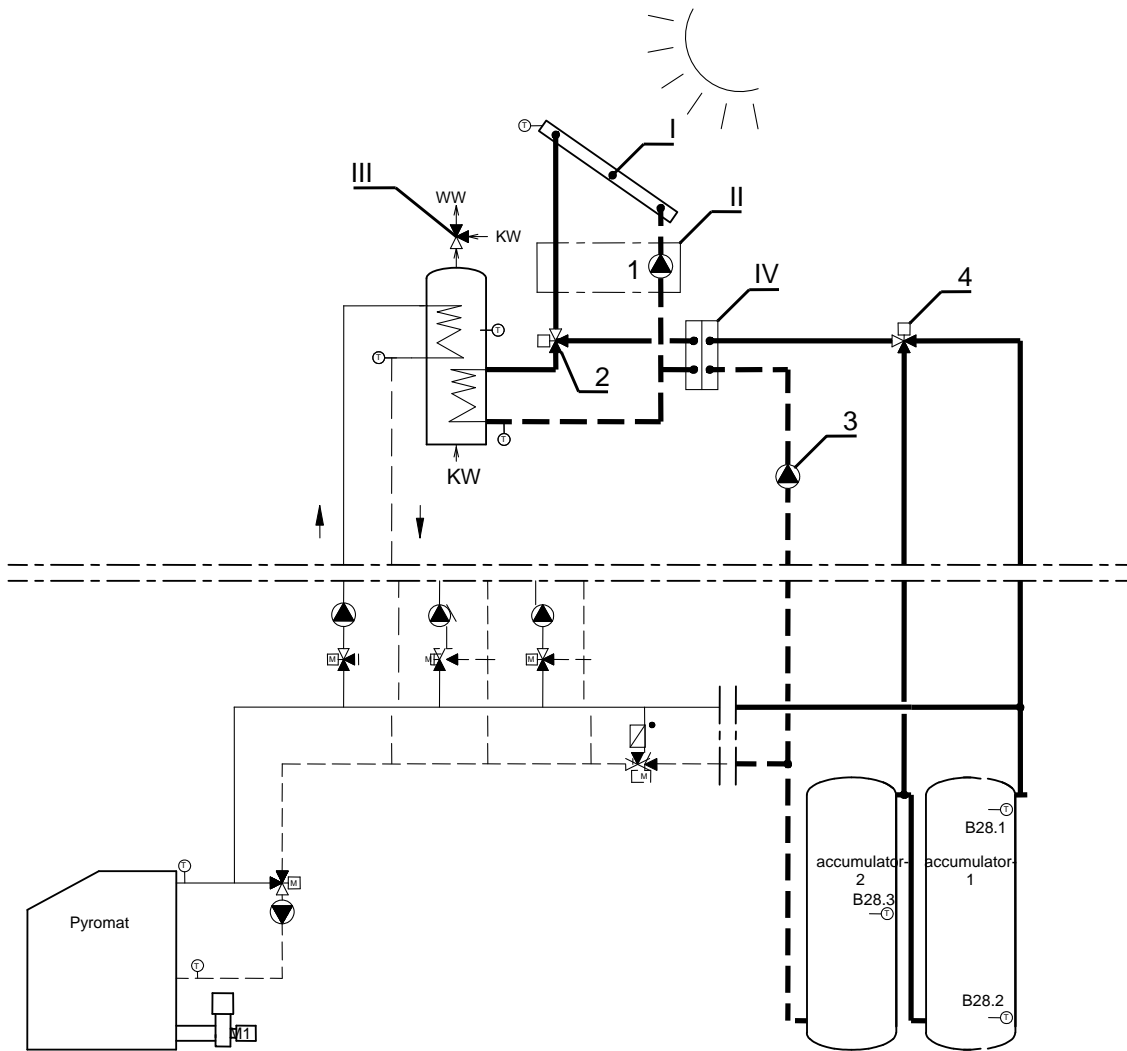

- I. solar collector
- II. solar station with solar pump
- III. thermostatic water mixer
- IV. plate heat exchanger
- 1. solar pump
- 2. inlet valve domestic water / accumulator
- 3. secondary pump
- 4. inlet valve accumulator front / back

example:  
 2 accumulators in series

example:  
 3 accumulators in series

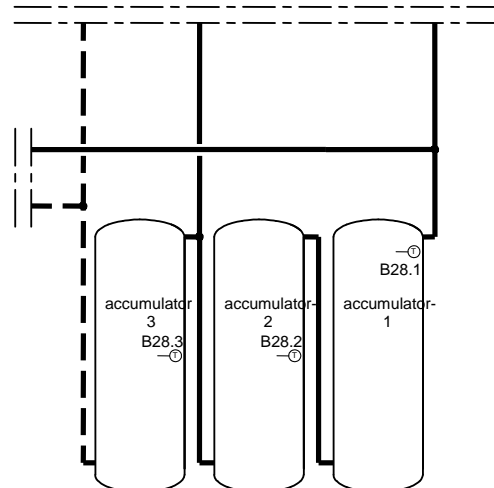



**Visualisation of Pyromat Internally [Art.-No. ECO-VIM / 7387780]****Visualisation of Pyrot Internally [Art.-No. ECO-VIR / 7387839]**

All the data is conducted to the PC by a data transmission line (max. 30 m) to the PC via the serial interface RS 232 on the control module. The current operational data for the boiler plant is visually shown on a function display with all the possibilities for entering values and functions as well as reading out the operational states (exception: "Start Boiler"). All the operational data is archived cyclically and can be graphically evaluated in a very simple fashion.

The PC and data transmission line are not included in the price.

Scope of delivery:

- CD with visualisation software and installation instructions

*Note requirements for PC provided by the customer:*

*Operating system: Windows 98 / 2000 / XP*

*Available hard disk storage space: at least 50 MB*

*RAM: at least 128 MB RAM*

*Per boiler: 1 available serial interface*

**Visualisation Supplementary Function [Art.-No. ECO-VIZ / 7387821]**

Extended visualisation [ECO- VII] with the functions of the keys additionally activated (from F4). Additional functions include each heating control unit (heat generator, heat consumer, solar system) as well as the automatic loading system (Pyromat DYN, Pyrot). Each function of the keys is displayed in a separate function display along with all the possibilities of entering values, reading out the operational conditions and archiving.

The price is per each additionally activated key on the control module.

Scope of delivery:

- Extension of the CD with visualisation software

*Note: For equipping possibilities, refer to Spec Sheet 4000-1*

**Data Transmission Line for Visualisation of Interior [Art.-No. ECO-ZLV / 7379404]**

Data transmission line consisting of:

- D-SUB plug for connecting control module to data transmission line, soldered
- 30 m data transmission line, triple-pole (cut to length according to dimension at location)
- D-SUB plug with threaded terminal ends, 9-pole, uninstalled, for connecting PC

**Installation (one fitter with helper provided by the customer) [Art. No. IMO-1 / 7387750]**

Performance provided by the contractor (supplier):

Furnishing the entire scope of the delivery. Installing the burner system, incl. all the machinery parts and facility components contacted by fuel and exhaust gas for the scope of delivery cited. Also included is the installation of all the limit switches, thermostats, probes and sensors supplied (exceptions: weather sensors and heat consumers).

The installation will be carried out by an experienced fitter (a qualified helper being required).

Price, incl. travel, expenses and overnight accommodation.

Performance provided by the client (buyer):

**1.) Prior to installation of the burner system**

- a) Equipping of construction site as follows:  
Paved access road to the construction site;  
230-V current supply line and, if necessary, 400 V for electric installation tools (welding apparatus);
- b) General construction work, as follows:  
Making all the installation holes required for the installation;  
Making the cement foundations and recesses for refill access lids and casings of extraction equipment;  
Pits and breakthroughs for fuel conveying equipment
- c) Construction work in particular as follows:  
Hydraulic sliding bar extraction system:  
Moving and setting in concrete the securing brackets supplied (if included in the scope of the delivery);  
Making the securing brackets (if not in the scope of the delivery). Due to the great forces that develop, this performance should be furnished according to the instructions of an expert (architect or structural engineer) in accordance with the supplier's specifications;  
Making the chimney system with the connecting hole for the exhaust pipe (exception: metal chimney included in the scope of the delivery);
- d) Draining the heating room and silo room with all the ducts and shafts required for installing the entire facility.
- e) Unloading the scope of the delivery from the truck unless the delivery has been expressly agreed with a crane truck.

**2.) Helpers during the installation of the burner system**

Providing a qualified helper to be available during the entire duration of the installation. Requirements for the helper:

- a) Qualified  
for installation work in steel and machinery construction (skilled at using hand tools)
- b) Physically sturdy  
no restriction to lifting loads, no restrictions to working up to heights of 3.0 m above the floor, no restrictions to hearing or sight
- c) Communicative and mentally stable  
good knowledge of German and mentally stable such that he can immediately follow the installation supervisor's verbal safety instructions
- d) Available  
during the agreed week days (Monday to Friday) from 7:00 AM until 6:00 PM
- e) Equipped  
with protective equipment according to the applicable regulations on industrial safety

**3.) After the installation of the burner system**

- a) Installation of the control cabinets delivered and/or the central control modules  
Unless expressly agreed otherwise, these must be installed by the authorised electrician.
- b) Installation of weather sensor and probes for the heat consumers in the scope of delivery:  
These have to be installed by the authorised electrician.
- a) Establishing the supply of electric current and carrying out the wiring unless expressly agreed otherwise:  
Electric input, 3 x 400 V, PE, N with fuses on control cabinet.  
Connecting cables between the control cabinet and the various motors and control units, connected on both ends so as to be ready for operation.
- d) Installation of the uninstalled water-bearing components included in the scope of delivery:  
Water-bearing components included in the scope of delivery not factory connected, such as pumps, valves, thermal run-off safety valves, accumulators, etc., must all be installed by the authorised heating engineer.
- e) Sealing all the openings between the burner room and the fuel storage space, doing so according to the fire prevention regulations.

**Installation (two Köb fitters) [Art. No. IMO-2 / 7387676]**

Performance provided by the contractor (supplier):

Furnishing the entire scope of the delivery. Installing the burner system, incl. all the machinery parts and facility components contacted by fuel and exhaust gas for the scope of delivery cited. Also included is the installation of all the switches, probes and sensors supplied (exceptions: weather sensors and heat consumers).

The installation will be carried out by two experienced fitters.

Price, incl. travel, expenses and overnight accommodation.

Performance provided by the client (buyer):

1.) Prior to installation of the burner system

- a) Equipping of construction site as follows:  
Paved access road to the construction site;  
230-V current supply line and, if necessary, 400 V for electric installation tools (welding apparatus);
- b) General construction work, as follows:  
Making all the installation holes required for the installation;  
Making the cement foundations and recesses for refill access lids and casings of extraction equipment;  
Pits and breakthroughs for fuel conveying equipment
- c) Construction work in particular as follows:  
Hydraulic sliding bar extraction system:  
Moving and setting in concrete the securing brackets supplied (if included in the scope of the delivery);  
Making the securing brackets (if not in the scope of the delivery). Due to the great forces that develop, this performance should be furnished according to the instructions of an expert (architect or structural engineer) in accordance with the supplier's specifications;  
Making the chimney system with the connecting hole for the exhaust pipe (exception: metal chimney included in the scope of the delivery);
- d) Draining the heating room and silo room with all the ducts and shafts required for installing the entire facility.
- e) Unloading the scope of the delivery from the truck unless the delivery has been expressly agreed with a crane truck.

2.) After the installation of the burner system

- a) Installation of the control cabinets delivered and/or the central control modules  
Unless expressly agreed otherwise, these must be installed by the authorised electrician.
- b) Installation of weather sensor and probes for the heat consumers in the scope of delivery:  
These have to be installed by the authorised electrician.
- c) Establishing the supply of electric current and carrying out the wiring unless expressly agreed otherwise:  
Electric input, 3 x 400 V, PE, N with fuses on control cabinet.  
Connecting cables between the control cabinet and the various motors and control units, connected on both ends so as to be ready for operation.
- d) Installation of the uninstalled water-bearing components included in the scope of delivery:  
Water-bearing components included in the scope of delivery not factory connected, such as pumps, valves, thermal run-off safety valves, accumulators, etc., must all be installed by the authorised heating engineer.
- e) Sealing all the openings between the burner room and the fuel storage space, doing so according to the fire prevention regulations.

**A prerequisite for approval is the express permission for such by the public authority responsible. For claims to the warranty according to Section 11 of our General Terms and Conditions of Delivery, wood fuels have to meet the following conditions. If those conditions are not met, then approval is possible with restrictions (warranty, maintenance, operational safety) with a written statement by the manufacturer in reference to the facility.**

**1) Non-combustible substances contained**

No wood fuels may contain any foreign bodies, such as pieces of metal, stones, masonry remnants or plastics. Nor must the following limits (per kg of dry fuel) for non-combustible substances contained (ash analysed at a temperature of 815°C) be exceeded or fallen short of:

	Limit	Comparison with untreated forest wood
1.1) Chlorine Cl:	max. 300 mg/kg	10 mg/kg
1.2) Sulphur S:	max. 1000 mg/kg	120 mg/kg
1.3) Total Cl, S:	max. 1000 mg/kg	130 mg/kg
1.4) Ash content, total:	max. 15.0 g/kg	5,0 g/kg
1.5) Alkali oxides in the ash (K <sub>2</sub> O and Na <sub>2</sub> O):	max. 1.0 g/kg	0.35 g/kg
1.6) Sintering point of the ash:	min. 1000°C	approx. 1200°C

Consequence of substantial overstepping of limits (1.1, 1.2, 1.3, 1.5, 1.6):

- a) Hot-gas corrosion in the heat exchanger → Special maintenance instructions for heat exchanger  
→ Shortened service life of heat exchanger
- b) Early sintering and melting of the ash → Special maintenance instructions for firing,  
→ Increased maintenance costs (firing, boiler door)

If the maintenance instructions are not followed, a process will be created that builds up in a negative fashion with:  
→ Cinders change the airflow → Temperature peaks → more slag → etc, until there is fast destruction of the refractory materials Fireproof materials

- 1.7) Additives in remnant and used wood: Free of heavy metals and halogen compounds

**2) Superfines & dust (wood particles smaller than 1.0 mm as per ÖNORM M 7133)**

- 2.1) Without pre-dryer, max. 10.0% of the total mass; consequence of substantial overstepping of limit:  
Temperature peaks → Slag formation → Even higher temperature → etc, to the point of destruction; → Special maintenance instructions for firing;  
Elevated values are especially critical for remnant wood in combination with elevated values as per 1.1, 1.2
- 2.2) For forest wood chips with pre-dryer, max 4.0% of the total mass; consequence of substantial overstepping of limit:  
→ Moving the exhaust air lines → Special maintenance instructions for cleaning exhaust air line.

**3) Origin and treatment**

- 3.1) Forest wood and plantation wood (complete trees and trunk wood untreated)**  
Mature wood from trunks and branches, untreated, chopped as billet wood or chips.
- 3.2) Compressed wood, pellets (conforming to standards, such as: ÖNORM M 7135)**  
Untreated wood with limited bark content, compressed by machine and calibrated
- 3.3) Increased proportion of bark, tree cuttings from roadside trees (untreated)**  
Remnants from the forestry and sawmill industries or from conservation of the countryside (elevated ashcontent).
- 3.4) Remnants from derived timber products**  
Normally a mixture of treated and untreated woods as shavings and from processing machines and chippings from slow-running choppers. With an elevated dust content and/or limited storage volume, the shavings from processing machines are compressed into briquettes.
- 3.5) Used wood**  
This is essentially untreated wood that has been used prior to its energetic utilisation (e.g. pallets). It is reduced in size by shredders for thermal utilisation. The metal parts have to be removed afterwards (by magnetic separators).

**4) Particle size: adjustment of the conveyor augers**

**4.1) G30/G50 chips from untreated wood as per ÖNORM M 7133:**

made by fast-running and cutting tools;

	max. coarse fraction	with cross-section	and length
G 30	of 20%	max. 3 cm <sup>2</sup>	max. 8.5 cm;
G 50	of 20%	max. 5 cm <sup>2</sup>	max. 12 cm;

Required cross-sections of the loading: depends on the boiler output:

	up to 150 kW	up to 500 kW	from 500 kW
Conveyor auger D	min. 12 cm;	min. 15 cm;	min. 20 cm
Drop cross-section A	min. 175 cm <sup>2</sup>	min. 300 cm <sup>2</sup>	min. 600 cm <sup>2</sup>

**4.2) Chips not from the forest; origin as per 3.2, 3.3, 3.4; briquettes, origin as per 3.3**

Size essentially as per ÖNORM M 7133 G50, additionally, however:

- Fraction of one-offs max. 5% with cross-section of max. 5 cm<sup>2</sup> up to a length of max. 16 cm
- Frayed surface by chopping tools (shredders) or slow-running choppers
- Briquettes, diameter max. D 60 mm (hydraulic compressors, pressure geared to loading system)
- Conveyor augers diameter min. 20 cm; drop-off route, rotary valve cross-section min. 600 cm<sup>2</sup>

Consequence of overstepping particle size:

- Extra expenditures for correcting malfunctions
- Shortened service life of the conveyor augers and drives

**5) Bulk density S (kg/m<sup>3</sup>), water content W (%), size G (mm) as per ÖNORM M 7133**

In automatically loaded boiler plants, the wood fuels that come to be used should be individually listed in offers and orders as follows:

a)	S 130	W10 to W20	G30/50	Sawdust, untreated (planing shop)
b1)	S 200	W20 to W35	G30/50	Sawdust, untreated (sawmill)
b2)	S 200	W20	G30/50	Forest wood chips, soft, untreated
c1)	S 250	W20 to W35	G30/50	Forest wood chips, soft, untreated
c2)	S 250	W35 to W50	G30/50	Sawdust, untreated (sawmill)
d1)	S 300	W20 to W35	G30/50	Forest wood chips, soft/hard, untreated
d2)	S 300	W35 to W50	G30/50	Forest wood chips, soft, untreated
e1)	S 350	W20 to W35	G30/50	Forest wood chips, hard, untreated
e2)	S 350	W35 to W50	G30/50	Forest wood chips, soft/hard, untreated
e3)	S 350	W50 to W60	G30/50	Forest wood chips, soft, untreated
f1)	S 400	W35 to W50	G30/50	Forest wood chips, hard, untreated
f2)	S 400	W50 to W60	G30/50	Forest wood chips, soft/hard, untreated
g)	S 130	less than W15	G30/50	Shavings & chips from wood remnants, dry, mixed
h)	S 200	less than W15	G30/50	Shavings & chips from wood remnants, dry, mixed
i)	S 250	less than W15	G30/50	Shavings & chips from wood remnants, dry, mixed
j)	S 350	less than W15	G30/50	Briquettes from wood remnants D 40 to 60 mm
k1)	S 650	less than W10		Pellets conforming to standards, untreated D 6 to 10 mm
k2)	S 650	less than W10		Pellets conforming to standards, untreated D 11 to 15 mm

**6) Maximum water content allowed, W, (percentage by weight of the total mass)**

The maximum water content allowed in the fuel when entering the furnace should be taken from the spec sheets for the furnace series. With a pre-dryer installed between the furnace and the fuel storage site, extra water content can be in the fuel stored (see specifications in reference to the order). The water content influences the maximum furnace output possible, the heat emission required to the pre-dryer and thus the maximum heat emission possible to the consumers.

**7) Other information**

**7.1) Ash and cleaning**

Untreated wood without bark has a proportion of ash less than 0.5% of the fuel mass supplied. All the specifications regarding cleaning involved are based on untreated wood with bark attached with an ash amount of 0.8%. The cleaning and maintenance involved for other wood fuels should be adapted according to the amount, the specific weight and the behaviour of the ash.

**7.2) Changing fuels**

A great change in fuel quality, such as bulk density, water content, dust proportion or ash content might make a manual correction of the firing parameters necessary (see Operating Manual).

**8) Non-woody fuels from biomass**

Non-woody fuels from biomass, such as needles, foliage, grain, straw, fruit pits, etc, are usually unsuited as fuel for trouble-free operation and thus are not approved.

**9) Wood fuels: rules, regulations and standards**

Germany:	1.BImSchV [Federal Immission Control Ordinance ] of 14.03.97 amended on 02.08.2001 page Fuels No. 5 to 7
Austria:	FAV dated 18 Nov 1997 "Feuerungsanlagenverordnung" (Furnaces Act § 3.(1) 3. Solid Fuels
Switzerland:	Luftreinhalteverordnung LRV (Swiss Clean Air Act) dated 16 Dec 1985 (Standing: 28 Mar 2000)
DIN 51731	Compressed Wood from Untreated Wood (1993)
ÖNORM M 7135	Compressed Wood from Untreated Wood or Untreated Bark (1998)
ÖNORM M 7136	Wood Pellets, Quality Assurance, Transport Logistics and Storage Logistics
ÖNORM M 7133	Wood Chips for Energetic Purposes (1998)
EN 303-5	Heating Boilers for Solid Fuels, Table 8 "Test Fuels"
CEN/TS 14961	Solid Organic Fuels

**I. Liability on Orders of Confirmation, Altering and Cancelling Orders**

1. If nothing different has been agreed on for the scope and execution of delivery, the order confirmation from the supplier is authoritative. If the technical data of the individual items of the scope of delivery are no longer listed in the order confirmation, the technical data of the most recent quotation apply.
2. If the order of the purchaser is also valid for the order confirmation, this is expressly stated on the order confirmation of the supplier with indication of precedence.
3. Insofar as there is no verifiable contradiction within 10 days of delivery of the order confirmation, the contract applies as concluded according to the order confirmation. In the case of delivery times shorter than 30 days, the time limit for objections is reduced to 30% of the delivery time.
4. Order changes or cancellations after expiry of the time limit for objections only apply if the supplier has declared its agreement in writing. In addition, the costs arising thereof must be borne by the purchaser.

**II. Prices**

1. The prices listed in the general documentation of the supplier (price lists) can, as a basic rule, be changed at any time without advance warning.
2. All prices listed in the supplier's documentation are to be understood ex works excluding VAT.

**III. Illustrations, Properties and Technical Terms**

All technical data, illustrations, measurements, diagrams and weights specified in bids, remain non-binding until they are part of a binding documentation delivered in connection with an order of confirmation. All rights for construction related changes remain reserved. Materials may be replaced by equivalent alternatives.

**IV. Copyrights and Ownership of Technical Drawings and Documentations**

Technical drawings and documentation that are handed to the buyer but do not form an integral part of the equipment and its applications, remain the property of the supplier. Only with the written consent of the supplier, may documents be passed on to third parties in a changed form or in the original form.

**V. Copyright and title to the control programs**

Control programs used to control the equipment remain the property of the supplier. With the full payment of the equipment, the buyer receives life-long, unrestricted user rights to the control programs.

**VI. Terms of Delivery**

1. If delivery dates are expressly agreed upon, they are binding.
2. Technical clarifications about all construction dimensions influencing the scope of delivery (loading device designed specifically for the building) must be submitted according to the following minimum deadline:  
42 days for systems with standard components  
70 days for portable building systems  
Multiple-boiler systems (complex large-scale systems) according to arrangement with the supplier.  
If the technical clarification does not permit production on time, for which the supplier is without blame, the supplier is excused from the deadline commitment.

3. The supplier is entitled to withhold the delivery if the agreed payment conditions have not been fulfilled by the purchaser.
4. If verifiable consequential costs arise for the purchaser through delayed deliveries, the contractual parties shall negotiate in regard to an amicable solution.
5. If the ordered goods are not accepted on the agreed delivery date, the supplier is entitled to issue an invoice for the goods. The contractual parties shall negotiate in regard to an amicable solution over the consequential costs of storage.
6. In the case of order on call, the supplier retains the right to only produce the ordered goods after receipt of the call.

**VII. Shipment /Transportation**

1. The supplier uses the type of packaging materials and means of transportation he deems suitable.
2. If no other agreement exists, the equipment is sold ex-factory. Furthermore, the INCOTERMS of the day of the contract signing is valid.
3. Should parts of the equipment be shipped individually at the buyer's request, then the additional cost will be to his account.

**VIII. Installations by the Supplier**

1. Has the mode of transportation and installation of the equipment been agreed upon, then the buyer is obligated to prepare the installation site on time and in the manner stipulated. These required preparations are listed in the confirmation of order under the position "Installation".
2. In general, a paved pathway suited for trucks that bring the equipment to the site must be prepared.
3. Furthermore, before installation starts, the masonry, carpentry and other preparatory work has to be moved along far enough so that upon delivery of the equipment, the installation technicians can take up their duties right away and carry them out without interruptions.
4. If installation must be interrupted as a result of insufficient progression of the of the masonry, carpentry or other workmanship, the purchaser must store the uninstalled items included in the scope of delivery and undertake all measures that would be made for the protection of its own property. The cost arising from the delay and additional travel expenses of the installation technicians are to the buyer's account.

**IX. Inspection/Complaints during Handover**

1. The purchaser is obligated to inspect the goods immediately on receipt. If the goods obviously do not correspond to the delivery note or exhibit visible defects, the purchaser must immediately indicate this on the delivery note in writing. If it neglects to do so the delivery and service apply as accepted.
2. A notice of defects not made on a timely basis also has the consequence of forfeiture of the supplier's warranty deed
3. If the purchaser would like an inspection inspection, this must be agreed upon in writing and, unless otherwise agreed upon, goes to the expense of the purchaser. Should the handover inspection for whatever reasons (that the supplier needs not stipulate), be delayed, then the specifications that are to be checked shall count as met until the opposite is proven.
4. Complaints do not void terms of payment.

**X. Notices of defects for defects not discovered on receipt of the goods**

The purchaser must give notice of defects identifiable on receipt (analogous procedure as in Pt. 9) as soon as they are recognised, however at the latest before expiry of the warranty period pursuant to Point 11.

**XI. Warranty/ duration and beginning**

It is expressly pointed out that the function of the delivery item during the warranty period and beyond is only possible if the specifications corresponding to the delivery item are precisely adhered to and fulfilled. The operational guidelines are an intrinsic part of the delivered equipment and essential to its correct operations.

Subjects of the specification include:

- a) The operating manual with the instructions on operating the equipment.
- b) In particular, the data of the fuels permitted and appropriate for the burner system (see Enclosure 1010-1 Minimum requirements for wood fuels, instructions)
- c) The handover certificate with the settings report and the specification of the fuel at the time of the handover
- d) Maintenance and service plan.
- e) The legal framework to be adhered to and fulfilled. Provided that this requirement is met, the following periods apply for the warranty:
  1. 5 years - on seal warranty for burners and tanks  
Warranty on water tightness of water bearing, welded construction such as the burner, heat storage tank and utility water heater (electric heater not included), is 5 years as of date of delivery.
  2. 2 years - for electrical and other parts  
The warranty deed for all electronic and other parts such as controllers, regulators, sensors and drives, motor-driven parts and parts that are not motor-driven, etc. persists for two years from the day of delivery.
  3. Normal Wear, Oils and Lubricants  
There is no warranty on parts subjected to normal wear such as seals, etc. Also oils and lubricants, such as hydraulic oils etc. carry no warranty. Normal wear is also present in the fire-proof coatings (surface wear, wear around the edges, cracks etc) that do not lead to any malfunction of the equipment- are not covered by warranty.

New parts carry the stipulated new parts warranty. No warranty extension on original parts that had no complaints.

**XII. Payment**

1. Payment must be made according to the agreed payment conditions. Reducing or withholding payments on the basis of complaints, credit memos that have not been issued yet or counterclaims not recognised by the supplier is not prohibited.
2. The terms of payment must be adhered to, even if minor, non-essential parts are missing in the delivery or must be reworked after delivery, as long as they do not impair the operations of the equipment.
3. If the purchaser is in default with an agreed payment or other performance, the supplier can either insist upon fulfilment of the contract and charge default
  - a) then the supplier may insist on the payment of the outstanding amount in rates or delay agreed services
  - b) extend the terms of payment on the outstanding amount

- c) invoice the buyer with the entire outstanding amount for immediate settlement
- d) interest at standard bank rates  
add the usual bank interest rates to the outstanding amount or step away from the contract after granting the buyer a reasonable period of respite.

**XIII. Liabilities**

The supplier is not liable to the buyer for any losses occurred due to interruptions in production, financial losses, missed opportunities, breakdowns, lost contracts or any other economical transaction or for any indirectly occurred losses.

**XIV. Limits of Liabilities**

Acts of God are unpredictable occurrences beyond the control of either party and may be the cause the contract not being partially nor totally fulfilled.

Acts of God in this case are:

Fire, conscription, confiscation, embargos, prohibition of currency transfers, rebellion, unavailable means of transportation, general lack of supply goods, limits set to energy consumption, plane crash, volcanic eruption, earth quake, avalanche, landslides, hurricanes, tidal waves, etc.

**XV. Jurisdiction and other regulations**

Frankfurt am Main is the jurisdiction. German law applies. The uniform law over the international purchase of chattel and the UN Convention on Contracts for the International Sale of Goods (CISG) are not applicable.



# EC-Declaration of Conformity

The Pyromat-ECO

with the models: Pyromat-ECO 35, 45, 55, 65, 75, 85, 61, 81, 101 and 151

were developed, constructed and manufactured solely by:

**Köb Holzheizsysteme GmbH**  
**Flotzbachstraße 33**  
**A-6922 Wolfurt**

**The Pyromat ECO corresponds to the requirements of the following guidelines:**

- 98/37/EC Machine Directive
- 73/23/EEC Low Voltage Directive
- 89/336/EEC EMC Directive
- 97/23/EC Pressure Equipment Directive

**Applied standards:**

- EN 303-5, DIN 4702  
Solid fuel burners, manual and automatic feeder systems.
- EN 60335-1 / A-14:98 Solid fuel burners, manual and automatic feeder systems.
- EN50081 Part1 and Part2, EN61000-6-2 (EN55022, EN61000-4-2, EN61000-4-3, EN61000-4-4, EN61000-4-5, EN61000-4-6)
- TRD 702

A complete technical documentation is included. The operation and installation manual is included in the language it was originally published in and in the language of the country to which it is delivered.

Wolfurt, 2009-05-02

Date

Signed

Dr. Stefan Hoffmann

First name, Name

Manager

Function









# **KÖB**

---

**VISSMANN** Group

**Köb Holzheizsysteme GmbH**  
Flotzbachstrasse 33  
A-6922 Wolfurt

Tel +43 55 74 / 67 70-0  
Fax +43 55 74 / 65 7 07

office@kob.cc,  
[www.kob.cc](http://www.kob.cc)

[Viessmann Group](http://www.viessmann.com)  
[www.viessmann.com](http://www.viessmann.com)