



Coimisiún na Scrúduithe Stáit
State Examinations Commission

Leaving Certificate 2015

Marking Scheme

Construction Studies

Higher Level

Note to teachers and students on the use of published marking schemes

Marking schemes published by the State Examinations Commission are not intended to be standalone documents. They are an essential resource for examiners who receive training in the correct interpretation and application of the scheme. This training involves, among other things, marking samples of student work and discussing the marks awarded, so as to clarify the correct application of the scheme. The work of examiners is subsequently monitored by Advising Examiners to ensure consistent and accurate application of the marking scheme. This process is overseen by the Chief Examiner, usually assisted by a Chief Advising Examiner. The Chief Examiner is the final authority regarding whether or not the marking scheme has been correctly applied to any piece of candidate work.

Marking schemes are working documents. While a draft marking scheme is prepared in advance of the examination, the scheme is not finalised until examiners have applied it to candidates' work and the feedback from all examiners has been collated and considered in light of the full range of responses of candidates, the overall level of difficulty of the examination and the need to maintain consistency in standards from year to year. This published document contains the finalised scheme, as it was applied to all candidates' work.

In the case of marking schemes that include model solutions or answers, it should be noted that these are not intended to be exhaustive. Variations and alternatives may also be acceptable. Examiners must consider all answers on their merits, and will have consulted with their Advising Examiners when in doubt.

Future Marking Schemes

Assumptions about future marking schemes on the basis of past schemes should be avoided. While the underlying assessment principles remain the same, the details of the marking of a particular type of question may change in the context of the contribution of that question to the overall examination in a given year. The Chief Examiner in any given year has the responsibility to determine how best to ensure the fair and accurate assessment of candidates' work and to ensure consistency in the standard of the assessment from year to year. Accordingly, aspects of the structure, detail and application of the marking scheme for a particular examination are subject to change from one year to the next without notice.



Coimisiún na Scrúduithe Stáit
State Examinations Commission

Scrúdú Ardteistiméireachta 2015

Staidéar Foirgníochta

Teoiric – Ardleibhéal

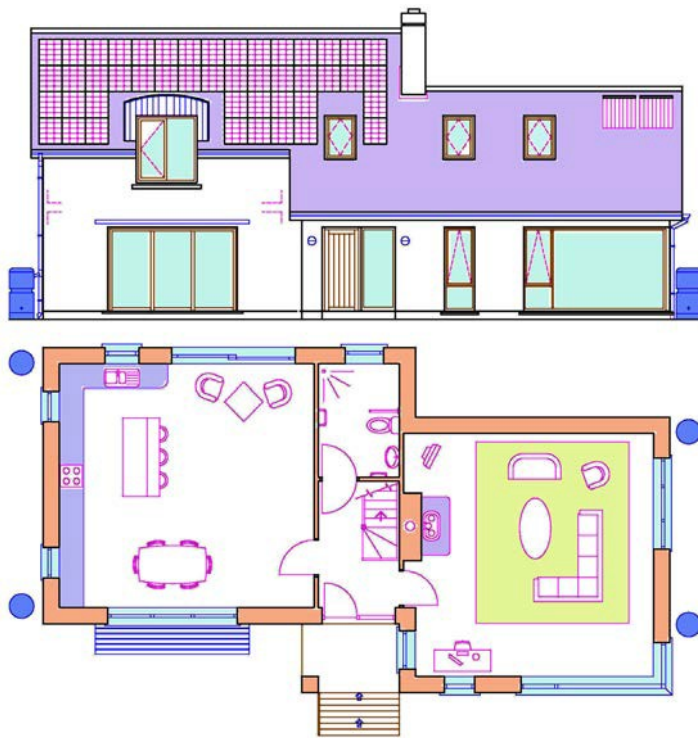

Construction Studies

Theory – Higher Level

Ceist 1 (i) Typical details for threshold, floor, door and wall details – foundation not required, thermal bridge free - such as

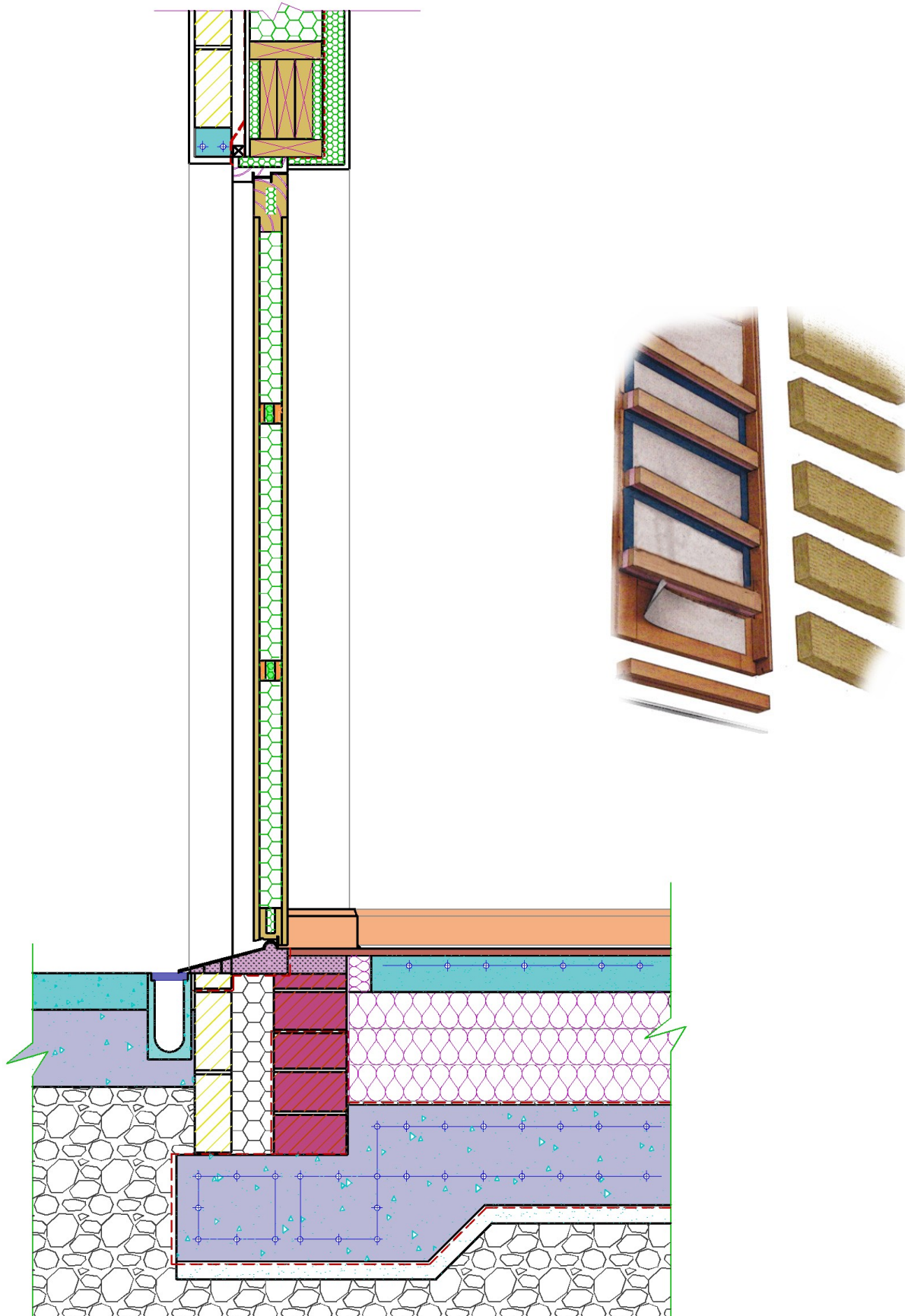

Wall - such as

- head plate and top rail 200 × 50 mm
- vertical stud framework 200 × 50 @ 400 mm centres
- horizontal bridging 200 × 50 mm
- racking board with vapour diffuse membrane
- vapour barrier membrane (VBM / ABM) to inside of inner leaf - joints sealed and taped
- insulated service cavity 60 mm
- vapour barriers/ tape at junction of wall and ceiling taped for airtightness
- 12.5 mm plasterboard - *best practice* - 2 × 12.5 mm gypsum plasterboard
- Skim/tape to ceiling and wall junctions
- insulation to timber frame - 200 mm
- racking board 12 – 20 mm OSB or plywood with taped joints
- vapour diffusion clear cavity 50 – 75 mm
- stainless steel wall ties
- fireproof cavity closer
- 100 mm concrete block outer leaf
- reinforced concrete lintel
- external render 15 mm – 2 coats.

Other appropriate detailing accepted**Ceist 2 (a) three functional requirements of an external wall - such as**

- keep the occupants safe, dry and warm – shelter from the elements
- support the floors/upper floor(s) and roof
- anchor roof to walls
- spread evenly the superimposed loads over the foundations
- provide robust openings for doors and windows
- have sufficient structural integrity to avoid cracks or other failure under load
- provide low-maintenance climate-proof exterior surfaces
- prevent the transfer of heat to the outside or to the inside of the dwelling
- insulate evenly against the formation of cold bridges
- prevent the formation of condensation and dampness
- prevent interstitial dampness
- prevent the uncontrolled passage of air through the structure
- stop the ingress of water
- prevent access of vermin to the building and the roof space
- be aesthetically pleasing and be in keeping with the surroundings of the dwelling.

Any other relevant points**(b) three different, distinct types of external wall - such as**

- concrete block with partial-fill insulated cavity
- concrete block with full-fill wide insulated cavity
- timber frame with insulated inner leaf and weatherproof external cladding
- timber frame with concrete block external leaf and insulated inner leaf
- light steel frame or combination wood and steel frame with insulated external cladding
- solid concrete block with external insulation and weather proof exterior finish
- timber frame with external insulation and weather proof external rain screen
- solid stone walls with breathable insulation and plaster
- straw-bale
- cob
- rammed earth.

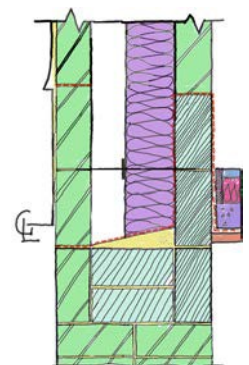
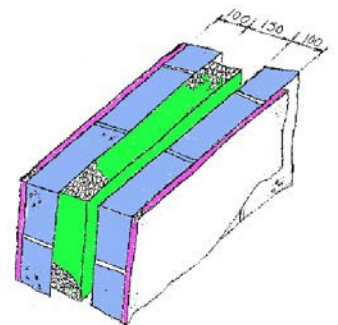
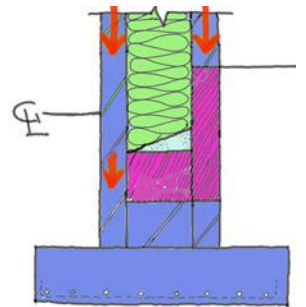
Any other suitable wall types that complies with current Building Regulations

(c) Evaluation of any two wall types - recommendation and justification - such as Concrete block with insulated cavity

- robust inside and outside
- readily takes a range of economical, easily applied finishes
- provides a heat sink in the blockwork of the inner leaf
- needs relatively more heat to bring the internal temperature up from cold
- the insulating materials are protected from accidental damage
- materials and skills widely available – traditional skills of blocklaying
- convenient and robust fixing for cills, windows, door frames and other components.

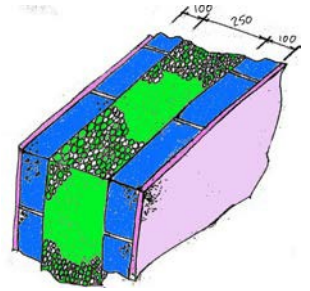

Timber frame with insulation and weather proof external cladding - such as

- easily accommodates greater thicknesses of insulation
- uses of sustainably produced materials – low embodied energy
- wood aids carbon sequestration
- reduces use of concrete – less CO₂
- quicker heating of living spaces - using less energy
- allows wide choice of rain screens and external finishes
- cement board can be used as external rain screen
- high air-tightness standard, particularly if sections are manufactured off-site
- services more easily accommodated within the service cavity
- quick to erect - saving on erection and drying-out time, can be assembled off-site.

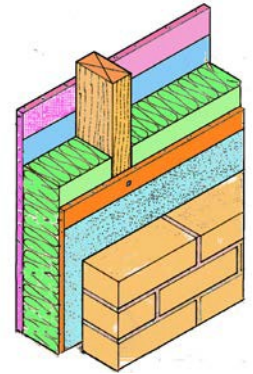

Timber frame with concrete block external leaf and insulated timber inner leaf - such as

- robust outer leaf - block laying skills widely available in community
- quick heating of living spaces using less energy
- uses sustainable wood and sequesters carbon
- readily takes a range of economical, easily applied finishes
- high air-tightness standard, particularly if sections are manufactured off-site
- services more easily accommodated in the service cavity
- speedily erected, saving on erection and drying-out time.

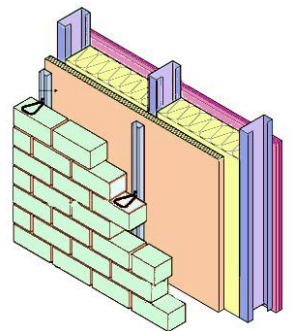

Light steel frame or combination wood and steel frame with external insulated cladding - such as

- speedily erected
- high insulation values possible
- more complex detailing required around openings, particularly in the fixing of door and window frames and at cills
- mounting of fittings, such as light fittings, rainwater goods etc, on external surface more exacting
- exterior finishes available more limited.

Concrete block wall with external insulation and weatherproof exterior finish - such as

- speedily erected
- high insulation values possible
- provides a heat sink in the inner leaf blockwork – high thermal mass
- simplifies the avoidance of thermal bridging
- careful detailing required around openings, particularly in the fixing of door and window frames, the formation of cills
- mounting of fittings, such as light fittings, rainwater goods etc, on external surface more exacting
- available exterior finishes more limited.

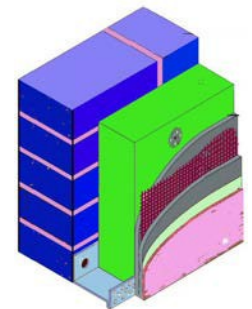

Timber frame with insulation and weather proof exterior rain screen - such as

- uses sustainable wood and sequesters carbon
- quicker heating of living spaces using less energy
- more readily achievable high air-tightness standard, particularly with sections manufactured off-site
- services more easily accommodated within the service cavity
- speedily erected, saving on erection and drying-out time
- simplifies the avoidance of thermal bridging
- more complex detailing required around openings, particularly in the fixing of door and window frames, the formation of cills
- mounting of fittings, such as light fittings, rainwater goods etc, on external surface more exacting
- exterior finishes available more limited.

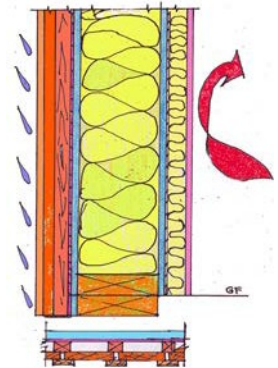
**Straw bale - such as**

- uses readily available, sustainable material
- use of straw aids carbon sequestration
- replaces 'chemical-based' materials with organic materials - less likely to impact on health
- quicker heating of living spaces, using less energy
- careful detailing required to prevent ingress of damp, rising damp and to prevent vermin attack.

Cob - such as

- uses readily available, sustainable materials – subsoil, straw and lime
- replaces materials which require high energy inputs in their manufacture – such as aluminium, concrete, steel etc
- helps control human-induced global climate change by replacing materials which lead to the release of carbon during manufacture, such as cement
- replaces 'chemical-based' materials with more naturally occurring materials less likely to impact on health
- provides a heat sink for storage of energy - enhancing passive heating.

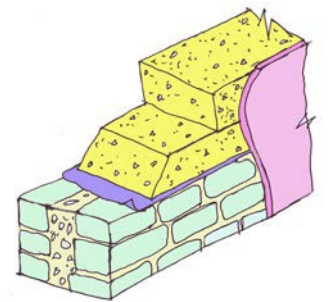
**Timber frame with hemp lime sprayed or cast - see sketch**

- no vapour barriers, open diffuse structure to roof and walls
- internal load bearing timber-frame to carry weight, to structural engineer details
- 300 – 500 mm Hempcrete cast or sprayed
- external limetec render
- internal Heraklith board with limetec internal plaster finish.

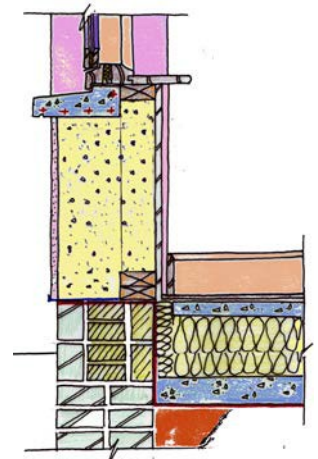

2(c) Evaluate any **two** wall types – recommendation and justification.

Analysis and cogent evaluation

Ceist 3 (a) (i) – Advantages and disadvantages of attached extension A and of free standing room B

Advantages - extension at A - such as

- saves on construction and insulation costs
- conserves space in the rear garden of the house
- more efficient for energy use; minimises the area of external walling
- provides for more freedom in the use of the total space in the living area with more options in the division of the total space created
- easy and economical to connect to existing services such as space heating, plumbing, ventilation, electrical distribution etc.
- compact construction - enhances the sense of coherence of the family unit and supports regular social interaction of all generations
- provides one large area in the house encouraging social connection of all.

Disadvantages: such as

- disturbs the well-proportioned layout of the house as originally designed
- provides a large undifferentiated space, needs careful designing
- can reduce the natural lighting and ventilation of the kitchen/dining room
- leads to increased energy use for lighting and heating – large space
- open plan versus discrete rooms, fewer spaces for a quieter environment
- may have negative impact on the view from the existing kitchen and the dining area
- new space may be remote from contact with the outside, especially if the kitchen is relocated to the bright area directly inside the new windows
- provides a challenge for continuity of insulation and proofing against water ingress at roof and wall abutment
- can have negative impact on the external appearance of the house
- can provide engineering challenges in the spanning of the larger opening required in the existing external wall, may have to strengthen walls and use RSJs to support external wall
- misses opportunity to connect the garden with the internal living spaces.

3. (a) (ii) *Advantages of free-standing garden room at B - such as*

- maintains the existing relationship between the kitchen/dining and the outside environment
- minimises disruption during construction
- maintains natural lighting to the existing rooms
- provides a greater level of privacy – distinct room in garden
- provide family members with space – young person or older person space
- provides more freedom of design in the new building
- provides more opportunities for enhanced natural lighting in the new construction
- provides opportunities for energy saving by increased use of natural lighting
- provides opportunity for enhanced linking of room and garden – bringing the outside in
- provides isolation for activities that require a quieter environment or that are noisy
- does not overshadow existing kitchen and dining room.



3. (b) (ii) Disadvantages of free - standing garden room at B - such as

- higher cost of insulation in external walls
- larger area of external envelope
- inconvenience of moving through the exterior garden space to the new building
- possibility of increased heating costs, due particularly to the provision of an extra exterior door and reduction in airtightness
- increase in unusable spaces in the vicinity of the exterior doors
- greater loss of natural space in the garden to provide for paths or other means of access
- fragmentation of living space for the family
- increased cost of providing access for all to the separate building
- cost of providing interconnection of services – space heating, plumbing and waste, electrical distribution etc.

**(b) Elevation - such as**

- a flat-roofed structure with a low elevation allows more light into the enclosed garden and doesn't impact negatively on the sense of space
- windows on the south elevation to ensure good natural lighting
- the space is divided to provide some privacy and a sense of seclusion
- a small office space is created for individual working at a desk
- the larger area is suitable for communal living
- a convertible couch provides occasional bed accommodation for visitors
- can be linked to house by covered walkway
- a paved area outside with wide-opening doors provides extended space linking to the natural garden environment.

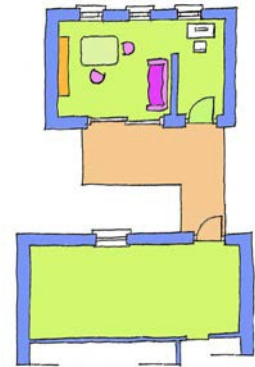
**Link to rear garden - such as**

- double doors to outside
- folding doors for ease of access to outside
- sliding doors for ease of access to outside
- floor to ceiling windows to capture views of outside
- patio to allow for seating and access to outside.

**(c) Possible advantages - such as**

- increased sense of wellbeing from closer contact with nature
- satisfaction of increased awareness of the changing seasons on a daily basis
- engaging the senses – sound, touch, sight – full enjoyment from location
- formative educational benefits for children
- health benefits of ongoing exposure to natural light
- link corridor to increase benefit of the amenity, particularly in spring and autumn
- increases use made of the valuable space outside
- provides a greater sense of spaciousness with little extra investment.

Any other relevant points

Any thoughtful, modern or traditional design with creativity and flair to enhance appearance of living/study space.

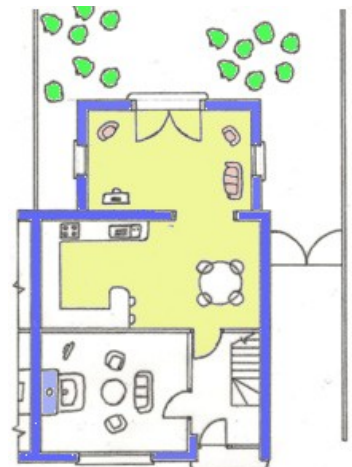

Ceist 4 (a) Eco-refurbishment of an old house built in the vernacular tradition:**Respect for local character - such as**

- vernacular architecture evolved from its location, giving the buildings an enduring appeal
- vernacular houses were usually built from materials gathered from the surrounding countryside, this gave a local distinctiveness and character to local villages, towns and individual buildings
- this knowledge was shared locally, houses were built using local materials and labour, refurbishment should reflect this approach as far as possible
- no standard formula in eco-refurbishment to suit every house, best practice approach requires careful planning and preparation to ensure that the building retains its historic character
- a holistic approach is needed to balance the particular needs of a traditional building with environment concerns and understanding the history of the building
- vernacular houses have lasted centuries because of their simplicity in design, refurbishment should respect this philosophy, keeping the materials, methods and detailing as simple as possible
- vernacular houses were built in less opulent times, so were modest in scale and carefully sized
- the “fabric first” approach involves upgrading the building fabric to reduce the need for fossil fuels for heating, to conserve energy and reduce CO₂ emissions and to future proof the dwelling
- the row of cottages reflect a unity, this harmony must be maintained in the refurbishment, otherwise it will be lost forever – respect for the neighbours and their dwellings
- conservation officer, architect, engineer or designer to give advice on best practice.

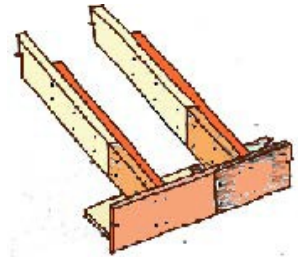
**Reuse of materials - such as**

- careful examination of complete house to determine what materials can be reused
- inspect all roof members for decay and replace only the decayed portions – see sketch
- remove decayed end of rafters and splice, inspect wall plate and replace if necessary with the same type of wood to maintain the historical integrity of the original roof
- replace decayed fascia/soffit where necessary, identical profile, treat with preservative - boron
- slating battens - replace existing battens and nails
- counter battens for ventilation of roof – if possible without affecting roof plane
- remove skirting boards, flooring boards, number and store and replace damaged with similar profile
- lift and number floor boards to ensure reuse
- replace any damaged boards with similar - from architectural salvage to maintain the patina of age and respect the character of the house.

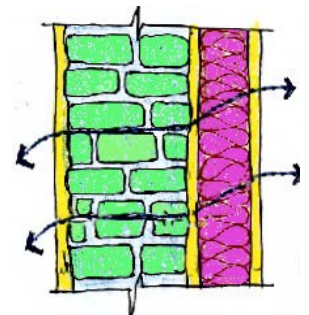
**Eco-refurbishment - breathable structure - such as**

- a breathable structure allows the gradual movement of moisture from the inside, through the building fabric – walls and roof
- allows moisture exchange readily between the indoor and outdoor environment, moisture is not trapped within the structure
- prevents surface and interstitial condensation occurring - as water vapour is not trapped but is gradually released
- ideally maintain the walls and roof as breathing structures – few barriers as in original

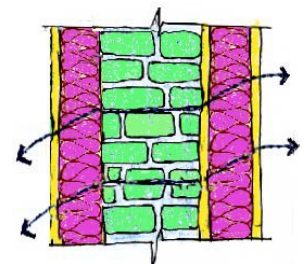

- insulation materials have to be carefully selected - natural insulation materials allow breathability, such as lime, hemp, cork, wood fibreboard, sheep's wool, cotton, flax, earth based mortars, renders, plasters and limewashes
- natural insulation materials are made from renewable or recyclable natural products, they allow the building to breathe and have excellent hygroscopic properties
- hygroscopic materials absorb the moisture from the air when the humidity is high and release it when the air is dry
- hygroscopic properties of the insulation will allow water vapour to move through the structure
- adding vapour barriers and materials that are highly resistant to the passage of water vapour is not usually appropriate for older buildings
- rule of thumb – all layers should become progressively more permeable from the interior to the exterior.

Suitable insulation materials include:

- hemp-lime composites, mineral wool, wood fibre panels, lime renders.

4 (b) eco-refurbishment of roof, sliding sash windows, suspended timber floor

Roof structure – insulation between rafters, cellulose, mineral woodfibre board on top of rafters with breathable membrane and counter battens:

- breathable – all insulation materials natural and hygroscopic, with no vapour barriers and water vapour diffuses at counter battens through roof vent
- the repair is to retain as far as possible the historic fabric of the roof
- remove slates, number each row and store
- reuse existing slate and replace with similar
- slate from rear placed on front roof to maintain uniformity of colour, shape and size
- remove impermeable sarking felt – to be replaced with vapour diffuse membrane
- inspect all roof members for decay and replace only the decayed portions – see sketch
- remove decayed end of rafters and splice, inspect wall plate and replace if necessary with the same type of wood to maintain the historical integrity of the original roof
- replace decayed fascia/soffit where necessary, identical profile, treat with preservative - boron
- insulate roof – all insulation materials to be hygroscopic – allow water vapour pass through
- sheeps wool between rafters, woodfibre board above and beneath rafters, lime plaster to fibreboard beneath rafters to allow moisture through
- slating battens – replace existing battens and nails
- counter battens for ventilation of roof
- fit vapour diffuse membrane beneath battens to allow any vapour diffuse to air – no sarking felt, impermeable as condensation occurs beneath.

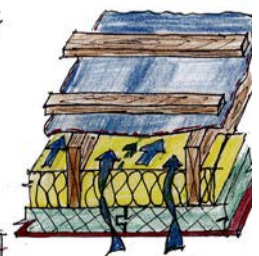
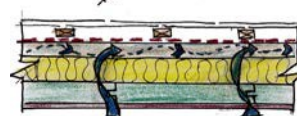
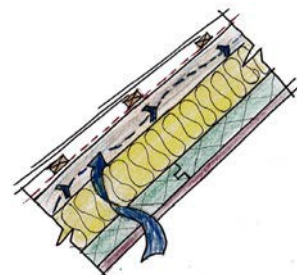
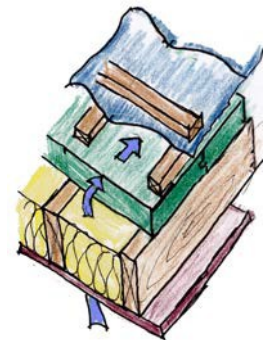
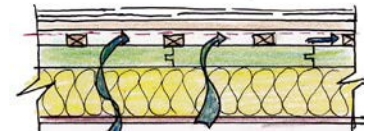
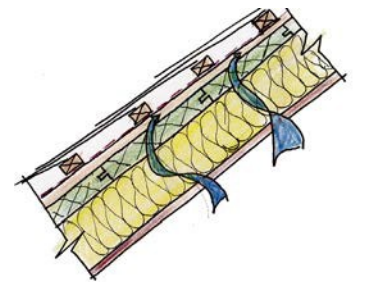

Other Option

- insulation to roof with ventilation path, or full-fill blown cellulose
- continuous vapour barrier on warm side of insulation, taped and joined to plaster layer
- insulated service cavity of hemp or wool - electrical services not to puncture vapour barrier
- vapour permeable ceiling board to form permanent shuttering to inside face such as Heraklith, Sasmox, Fermacell or similar
- vertical insulation to prevent cold bridge at wallplate.

Roofs – a guide to the repair of historic roofs - ISBN: 0-7557-7540-6 - Government of Ireland 2010

Windows – a guide to the repair of historic windows - ISBN: 0-7557-7538-4 - Government of Ireland 2007

Environment, Heritage and Local Government

Energy efficiency in Historic Buildings – english-heritage.org.uk

Hemp Lime Construction: A Guide to Building with Hemp Lime Composites: Rachel Bevan, Tom Woolley, Brepress.

Building with Hemp: Steve Allin, Seed Press.

SEAI - Retrofitted Passive Homes – Guidelines for upgrading dwellings in Ireland to Passivhaus standard.

Old House Eco Handbook – Suhr and Hunt – ISBN: 978 0 7112 3278 5

Any other relevant information**Softwood windows, single – glazed with sliding sash – preserving value and character**

- a common-sense ‘mend and make do’ approach is recommended
- original sliding sash windows add authenticity and character to an old building
- many wooden windows are over a century old, maintaining them now adds value
- historic windows and glass can withstand further wear and weather
- historically windows were made by skilled joiners and of high-quality timber that lasts for generations
- maintenance and repair of historic windows is recommended before replacement
- plate glass of uniform thickness was first produced in mid nineteenth century.

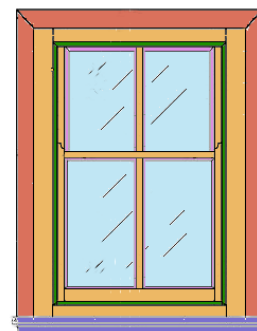
**The following options can be considered**

- repair existing windows frames and maintain existing glass *or*
- repair existing windows, apply draught-proof seals and re-glaze with double-glazed units *or*
- repair existing windows and fit secondary glazing to inside to upgrade thermal performance.

**Repair existing windows and maintain existing glass**

- survey the existing windows, draw diagram of each window, number the sashes and panes of glass
- remove the sashes from frames
- repair any damaged wood with similar species, usually red deal
- sand the wood, wax the surfaces to seal the wood or replenish wood with oil or pine resin
- repaint and allow paint to dry thoroughly before re-hanging sashes.

Remove cracked putty and re-glaze

- use a hot air gun with caution at a low heat - 50°C to 60°C - wear safety gloves and goggles *or*
- use a patented infrared putty lamp which softens the putty quicker than it heats the glass
- a hot air gun heats the putty to soften, without cracking the glass
- scoop out the putty and remove the glass
- clean out the rebate and apply boiled linseed oil to the rebate to prevent the wood absorbing the oil in the putty

- use best quality, well kneaded, traditional linseed oil putty and replace the glass
- use small electro-galvanised steel pins or copper glazing pins to hold the glass in position
- form a clean triangular bead of putty
- allow the putty to set and paint within one month, sealing it completely.



Check pulleys and cords

- check pulley wheels, clean and oil to remove grime
- replace pulley wheels with brass pulley wheels if damaged or worn
- clean all ironmongery with brass brush, avoiding abrasive creams and solvents
- check and replace any frayed pulley cords.

Repair existing windows, apply draught-proof seals and re-glaze

- remove glass, repair and sand sashes
- two types of draught-proofing seals – compression seals and wiper seals
- compression seals reduce the gap between sash and frame – for hinged windows - see sketch
- using router or spindle moulder, a groove is made in frames and draught-proof seals fitted
- wiper seals are usually a brush pile, held in a plastic carrier and used in sliding applications
- they are rebated in position, usually used at the meeting rails of the sashes
- glazing may be upgraded if rebates in sash deep enough.

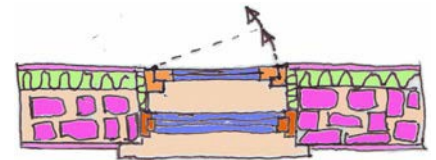

Repair existing windows and fit secondary glazing to inside to upgrade thermal performance

- remove glass, repair, sand the sashes and frames and repaint – windows are not draught proofed
- a secondary frame is fitted inside the main window- many different types - permanent, hinged for opening or sliding or removable
- secondary frame can be double or triple glazed
- secondary frame may be temporary – can be removed in summer
- frames and sashes to align with existing, secondary frame not obvious from outside
- frames not draught-proofed if secondary glazing used
- secondary glazing improves sound proofing.

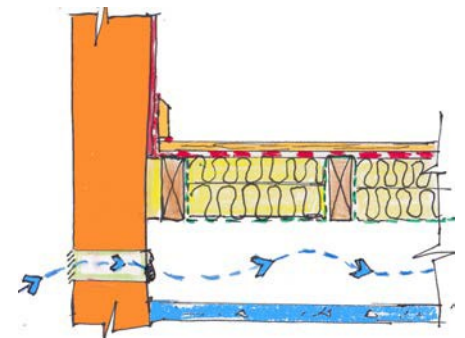
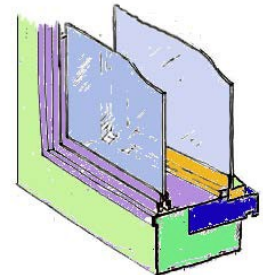

Floors

- determine historical significance of floor
- draw room plan, label/number floorboards and skirting
- carefully remove skirting and floorboards and store
- check sub-floor ventilation
- examine for any decay of joists or boards and replace
- spread netting and lay soft insulation between joists *or*
- fix battens and lay OSB or plywood
- fix rigid insulation between joists – cut accurately – friction tight, no gaps
- fix breather membrane, and replace floorboards as originally labelled or
- fix breather membrane, plywood and replace floorboards and skirting.

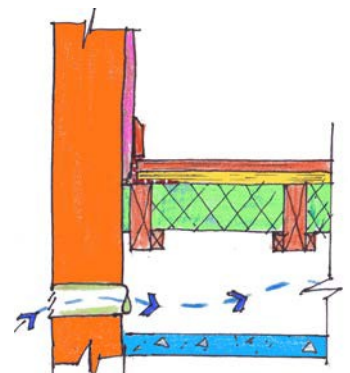

Ceist 5 (a): U-value

Material Element	Conductivity k	Resistivity r	Thickness T(m)	Resistance R
Ext. Render	0.720		0.016	0.02222222
Concrete Block(ext)	1.440		0.100	0.06944444
Insulation bead	0.031		0.250	8.06451613
Concrete Block (int.)	1.440		0.100	0.06944444
Int. Plaster	0.220		0.012	0.05454545
Ext. Surface				0.04800000
Int. Surface				0.12200000
Total R				8.45017269
Wall A			U-value 1/R	0.11834078
Wall B			Given U-value	0.21

Formulae: $R=T/k$ $R=T \times r$ $U= 1/R$

U-value: $U = 1 / 8.45017269 = 0.11834078 \text{ W/m}^2 \text{ }^\circ\text{C}$.

(b) (i) Cost of heat lost per year:**Wall A**

- Heat loss formula: = U Value \times area \times temp. diff
 $0.11834078 \times 150 \times 14 = 248.515631 \text{ Watts. (Joules / sec)}$
- Heating period p/a:
 $60 \times 60 \times 8 \times 7 \times 35 = 7,056,000, \text{ seconds (3,157hours)}$
- Kilojoules p/a:

$$\frac{7,056,000 \times 248.515631}{1000} = 1,753526.29 \text{ kJ}$$
- Litres p/a: (Note: Calorific value of 1 litre oil = 37350 kJ)

$$\frac{1,753526.29}{37350} = 46.94 \text{ litres}$$
- Cost P/A: (Note: 1 litre of oil costs 95cent.)

$$46.94 \times 0.95 = \text{€}44.60$$

Cost of heat loss annually through wall A = €44.60

Wall B with given U-value of 0.21 W/m² °C.

- Heat loss formula: = U Value × area × temp. diff
 $0.21 \times 150 \times 14 = 441 \text{ Watts. (Joules / sec)}$
- Heating period p/a:
 $60 \times 60 \times 8 \times 7 \times 35 = 7,056,000, \text{ seconds (3,157 hours)}$
- Kilojoules p/a:
 $\frac{7,056,000 \times 441}{1000} = 3,111,696 \text{ kJ}$
- Litres p/a: (Note: Calorific value of 1 litre oil = 37350 kJ)
 $\frac{3,111,696}{37350} = 83.31 \text{ litres}$
- Cost P/A: (Note: 1 litre of oil costs 95 cent.)

Cost of heat loss annually through wall B: $83.31 \times 0.95 = \text{€ } 79.14$

Alternative method

$$\begin{aligned} 0.1183 &= 44.58 \\ 0.21 &= x \\ 0.1183 x &= 0.21 \times 44.58 \\ x &= \frac{0.21 \times 44.58}{0.1183} \\ &= \text{€}79.13 \end{aligned}$$

Alternative method for part (b) Heat loss per annum through the wall

Formula: $\frac{\text{U-value} \times \text{area} \times \text{temp diff.} \times \text{time(secs)} \times \text{cost(€)}}{\text{calorific value} \times 1000}$

$$\begin{aligned} (1) &= \frac{0.1183 \times 150 \times 14 \times 7,056,000 \times 0.95}{37,350 \times 1000} \\ &= \frac{1,665,275,976}{37,350,000} \\ &= \text{€}44.58 \\ (2) &= \frac{0.21 \times 150 \times 14 \times 7,056,000 \times 0.95}{37,350 \times 1000} \\ &= \frac{2,956,111,200}{37,350,000} \\ &= \text{€}79.14 \end{aligned}$$

5(c) Typical detailing at window head to prevent ingress of water

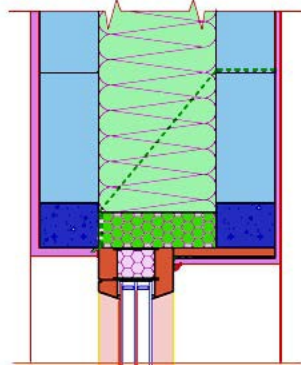

Notes and sketches

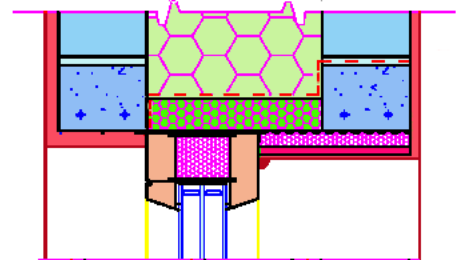

Any other relevant detailing / information acceptable

Ceist 6 (a)**Low environmental impact – features of house - such as**

- the overall height of the house makes it less obtrusive in the landscape
- the external surface area is reduced due to the two-storey form
- the high level of insulation provided by the timber frame construction reduces energy use for space heating, thus conserving the use of fossil fuels
- timber reduces use of concrete – less CO₂
- the utilization of the attic space reduces the use of materials, foundations
- solar efficient - long elevation on an east-west axis
- large areas of high-performance windows on southern elevation
- the compactness of the design reduces the volume of the air for space heating
- the use of water recovery minimizes run-off, equalises the return of water to the environment and reduces the requirement for provision of additional drainage infrastructure
- water recovery has potential for the replacement of treated water by grey water for certain purposes in the house thereby reducing the requirement for pre-treated water through the mains supply or well
- the area and orientation of the fenestration supports the use of passive solar gain to complement space heating
- positioning of solid-fuel heater and flue on an internal wall conserves heat within the house optimizes the conservation of heat within the house
- wood burning stoves are carbon neutral
- stoves are up to 70% efficient - open fires are at best 30% efficient
- the installation of solar water-heating panels on the roof helps reduce demand for centrally sourced energy for domestic water heating
- the installation of photo-electric collectors on the roof reduces the use of mains electricity replacing some of the mains power from renewable sources
- average annual consumption of electricity per household is 3.0 to 4.5 kW – an area of 21.0 m² of photovoltaic panels can produce 3.12 kW of electricity
- evacuated tubes to provide up to 60% of hot water requirements - less electricity used
- aim to provide all energy requirements on-site and to go off-grid
- trees to provide shade, food and shelter for birds and humans, to sequester carbon and aid biodiversity.

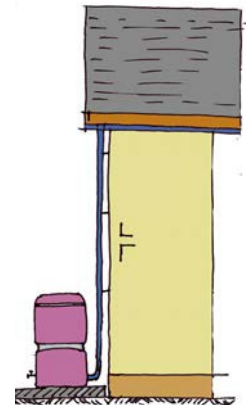
**Compact form - such as**

- reduced external surface area minimizes heat loss through the outer envelope
- the quantities of materials needed to enclose the volume of living space are minimized when the area of external surfaces is reduced
- the reduced use of concrete proportionally reduces the heavy carbon emissions involved in cement manufacture
- reduces the impact on the visual amenity
- the contained air volume to be heated in the house is reduced increasing efficiency in fuel use
- house is one room in width - easier to heat due to passive solar gain
- enhances opportunities for echoing traditional and vernacular themes in the house design
- the land surface used to provide space for housing is reduced
- the constraint of a compact form can lead to enhanced quality of design.

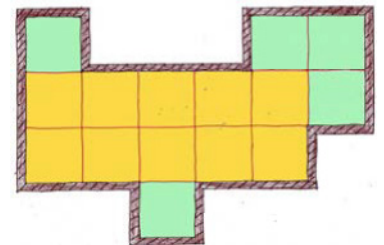

Flexible design - such as

- dwelling can respond, over time, to the changes of lifestyle and needs of those living in it without the need to undergo major structural changes or to be replaced
- can meet the needs of a wider range of people/families over time thus extending useful lifetime as the house changes owners – no steps indoors – suitable for all users
- bathroom designed for lifetime use, grab rails, swing door, wet room for shower
- more likely to facilitate easy adoption and retrofitting of emerging technologies
- home office/occasional bedroom easily made
- removal of wall to hallway to form larger open-plan area, easily modified – *see sketch*
- external hallway glazed for heat efficiency and solar gain, no direct access to outside
- can respond to seasonal variations in occupants' lifestyle, for instance by encouraging more communication with nature.

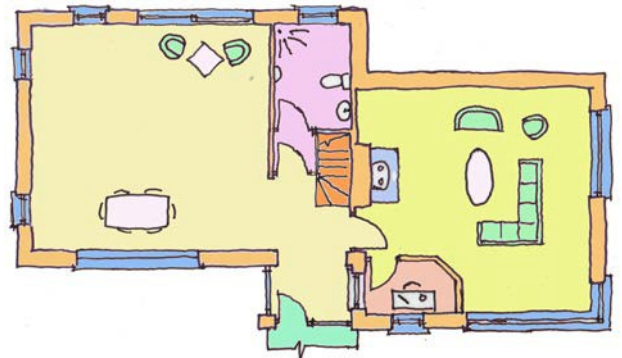
**Low maintenance - such as**

- reduces the use of energy and materials over the lifetime of the dwelling
- delays the eventual replacement of the dwelling and the use of scarce materials and energy
- maintains peak efficiency of the energy-saving and conservation aspects of the dwelling for a greater proportion of its lifetime
- boosts the householder's confidence and determination towards maintaining the low environmental impact of the building over its lifetime
- robust construction, will be a low maintenance building over its lifetime
- maintains the intended attractive and unobtrusive appearance in the environment over a longer lifetime.

**6. (c) NZEB**

The Energy Performance of Buildings Directive (EPBD) defines a nearly zero energy building as follows: A nearly zero energy building is a “*building that has a very high energy performance... . The nearly zero or very low amount of energy required should to a very significant extent be covered by energy from renewable sources, including renewable energy produced on-site or nearby.*”

EPBD does not prescribe a uniform approach for implementing nearly Zero-Energy Buildings and neither does it describe a calculation methodology for the energy balance.

NZEB standards to be introduced from 2019 for all publicly-owned buildings and from 2021 for all buildings.

Importance of designing NZEB for the 21st century - such as

- to help halt and reverse climate change induced by human activity and thus to avoid the consequences for the planet and humanity
- NZEB should not be seen as a stand-alone solution but as one important element of a broad range of actions needed to assure sustainability into the future
- sustainability in building cannot be brought about without co-ordinated suitably enforced standards being developed
- it is sensible to believe, if human activity is to be sustainable long-term, that humanity needs to return to more sustainable energy use and carbon release despite the considerable rise in world population
- NZEB is necessary not just due to the scarcity of fossil energy resources, but due to the absolute need to leave large proportions of the surviving fossil resources in the ground to avoid the release of additional free carbon into the environment

-
- the increasing scarcity of resources and the consequent rising cost of energy for heating and air conditioning is another reason for designing for NZEB
 - there is a moral imperative to provide fairness and equity in the use of resources, including energy resources worldwide, within the constraints of sustainable living
 - the additional energy resources required to provide equity in energy redistribution towards people in less-developed areas of the planet should be provided by reductions in energy use in industrialised countries
 - the raised and justified expectations of the growing world population, most especially in the developing world, is a reason for NZEB design, the alternative being a major lowering of expectations for all
 - there is a need to provide enhanced lifestyles for all, not just those in the privileged countries
 - there is an imperative to provide not just a short-term fix but a sustainable long-term solution to the prospect of run-away climate heating, to guard against the widespread impairment of civilization if not the extinction of humanity itself
 - there may be an achievable positive outcome to the problem of human-induced climate change if NZEB, together with a range of other actions, can be assured.

Any other relevant points

Ceist 7 - Typical details – Roof - such as

- slates on battens 50×40 mm
- counter battens 50×40 mm to provide air space
- breather membrane sealed and taped
- hygroscopic insulation layer – wood fibre board insulation or similar for windtightness
- rafters 200×40 mm at 400 - 600 mm centres
- collar ties 200×40 mm to each rafter
- ceiling joists 200×40 mm to each rafter
- vertical struts 200×40 mm
- runner at foot of strut - 150×70 mm
- struts 150×50 mm perpendicular to slope of roof
- purlin 200×75 mm
- service cavity to ceiling
- insulation 200 mm at slope of roof
- insulation 600 mm – two layers to ceiling
- 2×12.5 mm gypsum plasterboard to ceiling with vapour barrier on warm side of insulation
- airtightness tape
- fascia, soffit and gutter with continuous vent at soffit.

Wall – such as

- 400 mm external wall
- full-fill cavity insulation
- internal and external plaster/render
- cavity closer
- 100mm load-bearing centre wall.
- **Other appropriate detailing accepted**

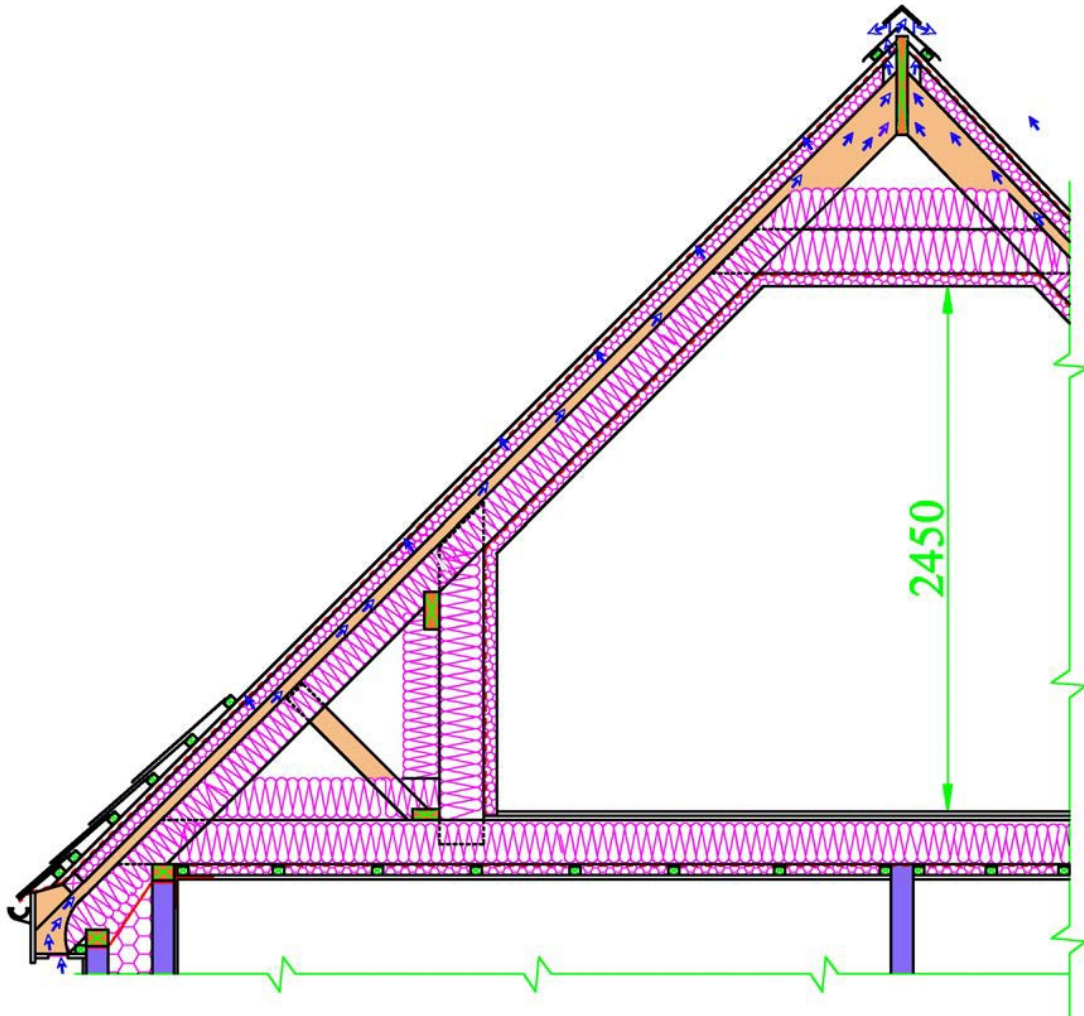

Ceist 8 (a) – Design of zoned heating system - such as

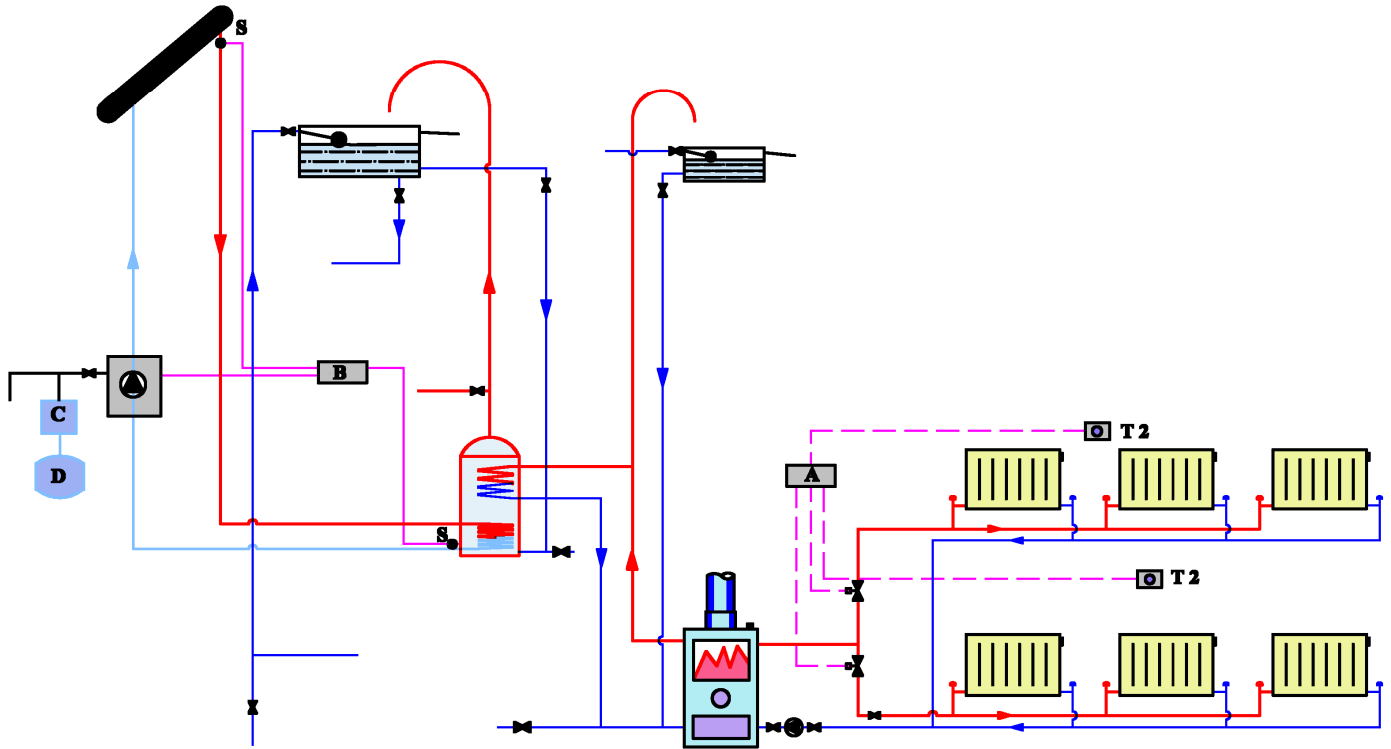
**Control Valves**

- control valves located on return
- independent thermostatic control on each radiator
- motorised control valves to each heating zone located on flow
- zone thermostats at T1 and T2
- electronic heating control panel at A
- isolator/drain valves located on return
- solar controller located at B
- temperature reducing vessel located at C
- expansion vessel located at D
- temperature sensors located at S

Typical pipe sizes

- 22mm flow and return
- 15mm on up stands
- 28mm expansion
- 300 litre capacity hot water twin-coil cylinder
- 230 litre cold water storage

(b) Preferred location of solar collector- such as

- optimum efficiency achieved when solar collectors oriented south
- tolerance of 15° - east or west of south
- avoid locating in areas of shade i.e. trees or chimney
- usually placed on roof, however may also be positioned on south facing gable walls or independently placed at ground level
- reinforcing of roof may be necessary depending on number and weight of solar collectors
- ensure correct sizing to achieve maximum efficiency

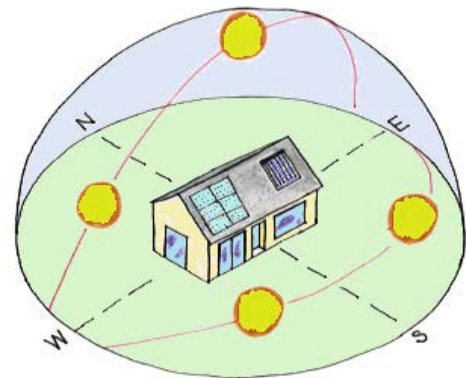

- as a rule of thumb allow 1.0 -1.5m² solar collector area per person for water heating needs
- all pipe work to be insulated to avoid heat losses and UV stable if exposed
- PV panels can provide up to 60% of domestic electricity need
- performance of collector may be affected by overheating
- ensure air flow over the back of the collector
- maximum radiation yield can only be achieved when solar collector is inclined to horizontal
- optimum tilt angle for solar collector 45°.

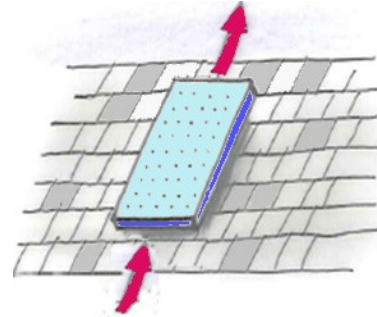
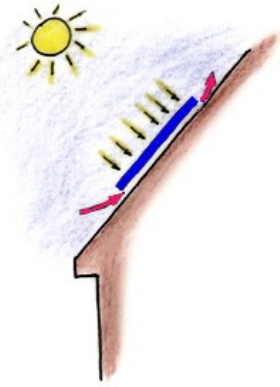

(c) **Design considerations for chimney and hot press location**
Chimney- such as

- locate on internal wall
- compact design – chimney, hot press and bathroom all located close together
- high thermal mass of chimney breast allows heat to be stored and radiated back to adjoining spaces
- all pipework - hot and cold - to be insulated.

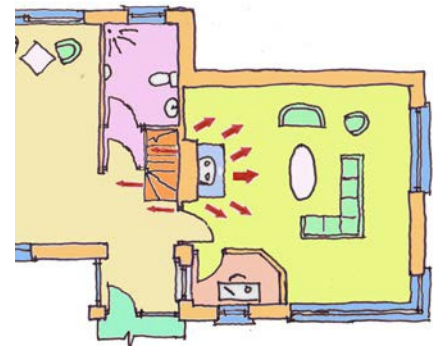

Hot press - such as

- contains hot cylinder and associated valves and pipework
- hot water cylinder to be positioned as close to the boiler as possible
- short pipe runs, less water to heat, less pipework necessary
- located close to boiler to reduce heat loss and volume of water to be heated
- ensures quick heat up time – flow and return as short as possible
- all pipework, hot and cold, cylinder and tanks to be fully insulated.

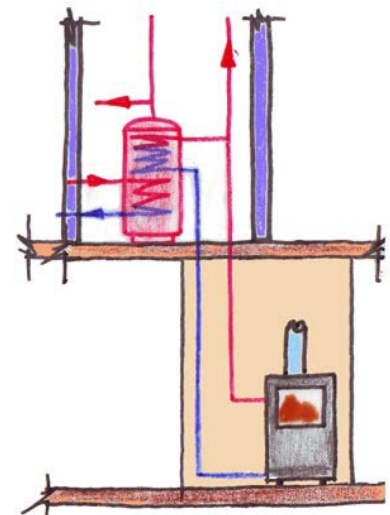
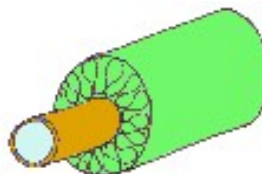
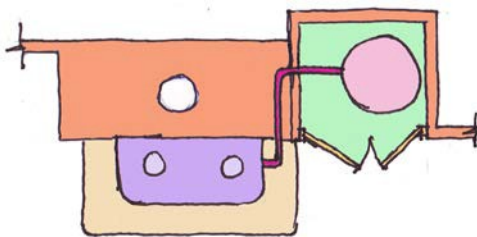

Q.9 Thermal bridge free design - three locations**Floor detail – such as**

- a thermal/cold bridge is an area of a building that has a higher heat transfer than the surrounding materials, resulting in a reduction in thermal insulation of the building
- thermal bridging reduces energy efficiency and thermal comfort
- thermal bridging is prevented by careful design - to achieve uniform thermal resistance, with no thermal breaks, and continuous insulation
- best practice - a perimeter 80 mm insulation strip installed up to floor level
- ensure wall insulation is carried down at least 225mm below the top of the finished floor.

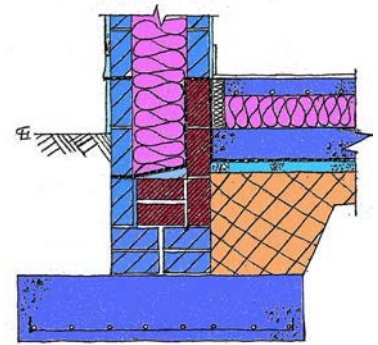
**Head of window opening - such as**

- 250mm full-fill cavity insulation
- 60mm cavity closer
- internal concrete lintel 25mm above external lintel to allow for insulation wrapping the window frame
- 15mm insulation overlapping window frame
- insulated plasterboard finish to reveal.

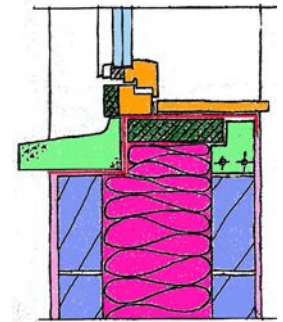
**Window cill - such as**

- insulation at back of cill to prevent cold bridge
- high density proprietary cavity closer for fireproofing
- cill does not bridge cavity
- triple-glazed window to Passive House standard - 0.8W/m² K or equivalent
- 60 mm cavity closer
- 250mm full-fill cavity insulation
- airtightness tape to window frame.

Ground floors abutting external walls - such as

- cavity insulation
- 80 mm insulation between concrete floor slab and inner leaf of wall
- 150 – 300 mm insulation between floor slab and subfloor
- 100 mm aac – autoclaved aerated concrete – blocks below ground level.

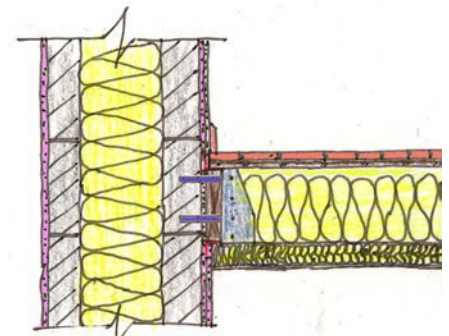
**Junction of upper floors and external walls - such as**

- joist to hang on inside leaf, no penetration of leaf and cavity
- wall plastered to increase airtightness
- resin anchored bolts to support floor joists – see sketch
- joists supported on metal hangers .

Junction of roof and wall at eaves – such as

- 60 mm rigid insulation board
- 400 fibreglass insulation
- 60 mm cavity closer
- AAC (autoclaved aerated concrete) block
- 250 mm full-fill cavity insulation.

(b) Thermal bridge free envelope

A number of problems arise when instances of thermal bridging occur in the envelope of a domestic building. These problems can be very serious and can impact on the health and wellbeing of those living in the building as well as causing unsightly deterioration of the building fabric.

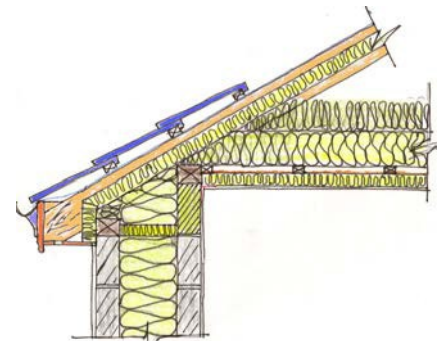

- thermal bridging occurs as a result of localized variations in insulation - where the insulation is less effective the envelope is a more efficient conductor of heat

- where thermal bridging is present, a higher proportion of heat energy passes through the affected part of the building envelope to the outside - where the temperature is lower, the heat loss is uneven resulting in relatively hotter and colder surface areas inside the building
- this causes variations in the temperature differential where warm air comes into contact with the colder materials of the inner surface of the building envelope
- the damaging effects of thermal bridging arise from warmer air coming into contact with the colder surface areas where it is cooled to its dew point depositing the released water as moisture on the surface
- the resulting damp patches support the growth of moulds which are unsightly, produce odours, cause staining and rapid deterioration of materials and finishes and can adversely affect human health when airborne spores are inhaled
- in extreme cases building materials and components such as plaster, wood and steel can be compromised and fail
- the heat loss also needs to be made good to maintain the comfort and health of residents - this increases the overall energy demand and the use of resources for heating making the building less sustainable.

Q 10 (a) - airtight building envelope

- build tight and ventilate right
- airtightness prevents unregulated air leakage and unregulated air infiltration
- an airtight building envelope enables control of fresh air intake into a building
- airtight building envelope ensures no unregulated heat loss through building fabric, especially at junctions
- pen on section line - see continuous red line in sketch to indicate unbroken airtight barrier
- wall and floor junctions, wall and window junctions, wall and door junctions, ceiling and wall junctions, chimney and ceiling junctions
- air leakage is prevented by providing unbroken air barrier membrane on the warm side of the insulation and by taping of all junctions
- continuous airtight seal around the internal fabric of the external envelop eliminates draughts
- proprietary tapes to tape concrete to concrete, plasterboard to concrete, concrete to wood
- proprietary mastics to seal skirting to wall and floor, window boards to wall and window frame
- continuous gypsum skim coat, with scrim reinforcing at joints and junctions acts as a airtight layer
- intelligent barriers allow vapour diffusion when required
- airtight vapour barrier on warm side of insulation ensures interstitial condensation is reduced
- vapour barrier should be continuous and not be punctured
- a small tear in vapour barrier renders it ineffective
- winter – diffusion tight; summer diffusion open
- grommets used to seal around pipes and cables passing through vapour barrier
- best practice - service cavity eliminates risk of puncture of vapour barrier by services
- blower door test used to determine effectiveness of air tightness barrier.

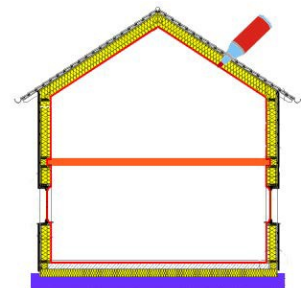

Space heating demand

A Passive House must meet **three** criteria for energy performance:

- **space heating demand** is the energy required to maintain an indoor temperature of 20°C all year round.
- **space heating** refers to the heating of the indoor spaces. It does not include hot water heating or other energy needs
- space heating demand for a Passive House is specified at $\leq 15 \text{ kWh/m}^2/\text{a}$
- **heating load** is the energy required to maintain an indoor temperature of 20°C on a given day - the heating load must not exceed the amount of heat that can be supplied to the house via the fresh air required for good indoor air quality
- **heating load** is specified at $\leq 10 \text{ W/m}^2$

- The **primary energy demand** is the total energy consumed for all requirements (i.e. space heating, water heating, ventilation and electricity).
- primary energy is the energy required to deliver usable energy to the home - this includes the energy consumed during extraction, conversion, transport and so on
- in Ireland the primary energy conversion factor for electricity is currently 2.58. This means that for every unit of electrical energy consumed in the home, 2.58 units of energy have to be produced
- **primary energy demand** is specified at $\leq 120 \text{ kWh/m}^2/\text{a}$, however many Passive Houses exceed this and would achieve a primary energy demand of between 60 to 70kWh/m²/a.
- **primary energy demand** is specified at $\leq 120\text{kWh/m}^2/\text{a}$.

Indoor air quality

- most life spent indoors – indoor air quality and healthy indoor environment most important
- space, warmth, light and air all affect the internal environment of a dwelling
- thermal comfort is the expression of satisfaction with surroundings – too hot, too cold or just right
- thermal comfort also influenced by humidity, draughts, temperature of surrounding surfaces, each individual's metabolic rate, clothing etc
- increased levels of airtightness requires careful design of ventilation system to ensure continuous supply of clean, warm, filtered, fresh air
- properly designed ventilation systems limit humidity and prevent mould growth and the build up of pollutants through extraction
- in Passive House this is achieved with Mechanical Heat Recovery with Ventilation (MHRV) system – ducted and ductless systems now available
- MHRV unit, as shown, provides whole house ventilation and a regular controlled supply of fresh, cleaned air to all rooms
- warm moist air “extract air” is mechanically extracted from kitchen, utility room, bathrooms and toilets
- outdoor air passes through a fine filter in the heat exchange unit to ensure dust, pollen and other contaminants are removed from the air - this ensures clean, fresh air to all the house
- in the MHRV unit, the ‘extract air’ and the ‘outdoor air’ do not mix - instead, they pass through a heat exchange unit. This unit is made up of a number of very thin metal or plastic plates. The heat in the extract air heats one side of each plate. The outdoor air passes on the other side of the plate and absorbs this heat energy. The outdoor air is now warm and filtered and is now called ‘supply air’. The ‘supply air’ is pumped to the living spaces (‘supply zones’)
- MHRV system designed to provide minimum air temperature at 16.5° when outdoors at -10°
- during cold weather a post heater is used to raise the temperature of the incoming air to ensure a constant comfortable temperature of 20°C is maintained in the home at all times. During warm weather a ‘summer bypass’ is used to bypass the heat exchanger so the supply air does not cause overheating.
- MHRV designed for maximum of 0.6 air changes per hour (ach/hr)
- insulated ducting prevents condensation and mould growth in the ducts
- windows can be opened in summer for fresh air and to cool the house if overheating
- Passive House designed to have indoor temperature at 20° throughout year
- filters in MHRV should be changed every three to six months to ensure air is properly cleaned
- relative humidity of the indoor air should be in the range 30% to 60% - within this range the benefits of water vapour in air are optimised – air not too dry or too moist - keep all areas clean and dry and get rid of excess water or moisture

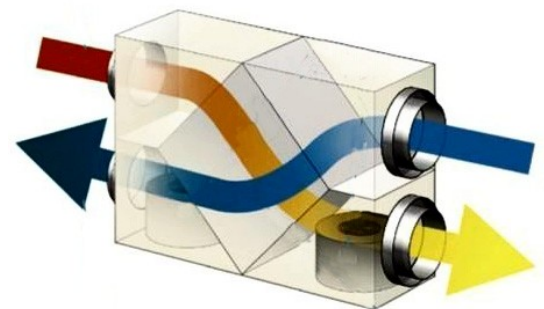
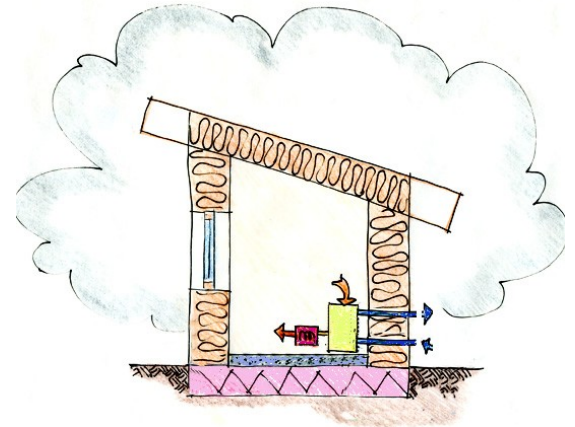

- filtered air prevents and the growth of mould, dust mites and other viruses and bacteria, reducing respiratory illnesses
- internal CO₂ levels ideally less than 1000 ppm (parts per million)
- to prevent condensation and mould growth the temperature of internal surfaces (e.g. walls, ceilings, windows) should not fall below 12.6°C
- inspect fuel-burning appliances regularly by professional for leaks and make repairs when necessary
- install a carbon monoxide alarms and test for radon gas
- houseplants, such as the Spider plant - *Chlorophytum comosum* – shown, absorb some airborne contaminants, together with the medium in which they are grown, and reduce indoor air pollution, particularly volatile organic compounds (VOC) such as benzene, toluene, and xylene
- plants remove CO₂ and release oxygen and water, although the quantitative impact for house plants on indoor air quality is relatively small.



Performance criteria of MHRV system - three main requirements:

- 30m³/hour/person of fresh air must be supplied.

extract requirement:

- kitchen 60m³/hour
- bathroom 40m³/hour
- toilet/ store/ utility/ en-suite 20m³/hour.

air change requirement:

- the system must be balanced for the entire dwelling to ensure that a minimum air change rate of 0.3 air changes per hour (ac/h) is achieved, with maximum of 0.6 ac/h.

10(b) – Importance of thermal mass in Passive House design:

- in passive solar design, the cheapest energy for space heating comes from the sun
- solar radiation comes in through large south-facing windows and is absorbed and stored by the heavy materials of the building
- thermal mass describes the ability of a material to absorb and store the sun's heat - creating a heat sink
- thermal mass regulates internal temperature by
 - (i) reducing the peak temperature through absorbing the sun's energy at peak temperature and
 - (ii) releasing the heat back into the building at a later time. Thus the more mass there is in a building, the lower and later the indoor temperature peaks
- concrete walls and floors are the most common form of thermal mass in a Passive House
- thermal mass regulates indoor temperature
- in the summer, this helps to stabilise the internal temperature and prevent overheating
- solar gain through the windows is absorbed by the concrete block walls and concrete floors
- during the evening/night, the solar energy absorbed by the floor and walls during the day is released, balancing the internal temperature and reducing energy consumption
- for a material to provide a high level of thermal mass, it must have -
 - high specific heat capacity – to maximise the heat that can be stored per kg of material
 - high density – to maximise the overall weight of the material used
 - moderate thermal conductivity – so that heat conduction is in sync with the heat flow in and out of the building
- heavyweight construction materials such as brick, stone and concrete have these properties
- these materials combine a high storage capacity with moderate thermal conductivity
- this means that heat transfers between the material's surface and the interior occurs at a rate that matches the daily heating and cooling cycle of the dwelling.

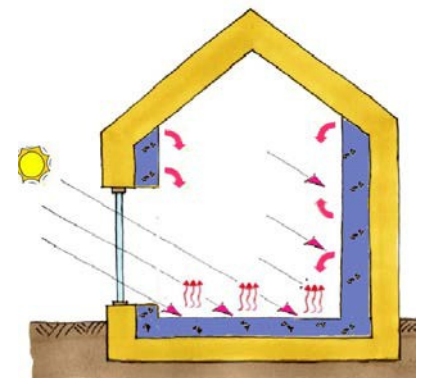

10(c) – Importance of carefully designed solar shading in Passive House design

- carefully designed solar shading filters the direct rays of the sun and helps prevent overheating and glare
- overheating occurs in Passive design if internal temperature greater than 25° for 36 days (10%) days annually.

Solar shading**Extended roof overhang**

- an overhang / extended eaves / to reduce the solar heat gain in summer
- the angle of the sun is higher during the summer than it is during the winter
- with a correctly designed overhang, direct solar heat and glare is reduced.

Brise Soleil

- This works on the same principal as the overhang and is used to reduce the amount of summer sun entering a building.

Vertical pivot brise soleil

- pivot shading can be adjusted to suit the weather conditions at a particular time – *see sketch*
- external roller blinds, awnings and sliding screens can also be used.

Balconies

- balconies must be designed and sized to filter the light and reduce overheating – avoid thermal bridge.

Blinds, shutters, curtains

- not as effective, but assist in reducing overheating.

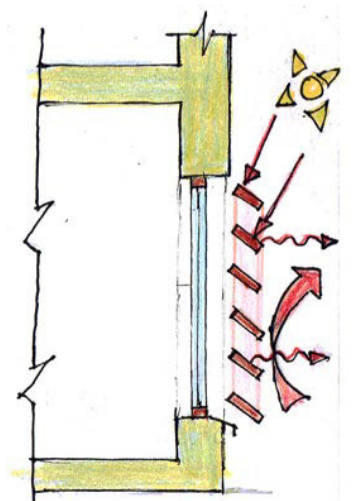
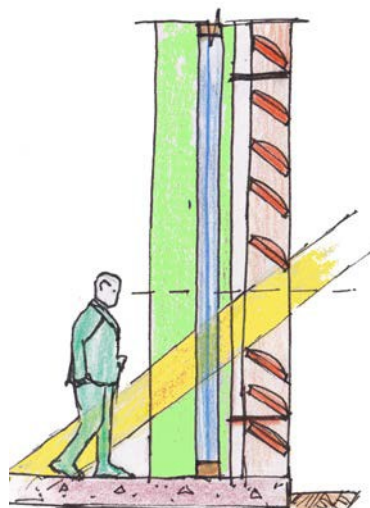
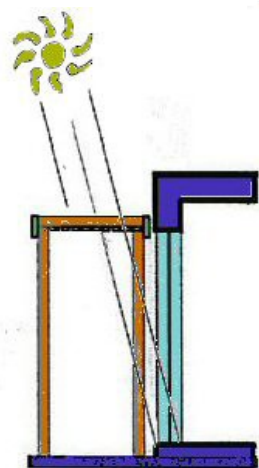
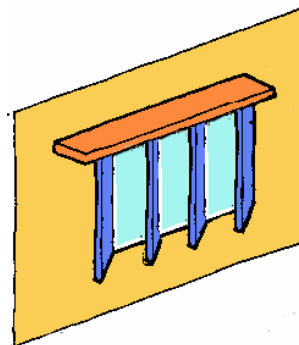
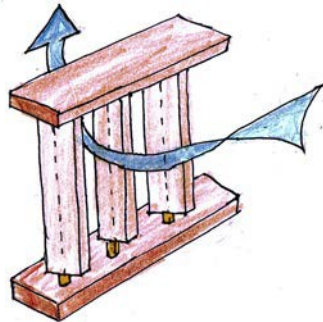
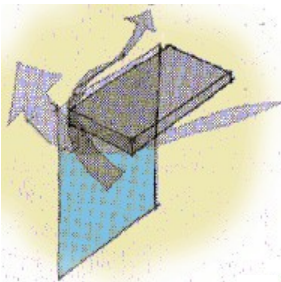

Question 10 – alternative

Light is what architecture is all about. It is as fundamental for the soul as air, fire, earth and water. Light has been one of the key elements of architecture since the Modern movement began (and glass technology improved) at the turn of the 20th century. Yet, light has traditionally been lacking in Irish homes. Many old cottages only have windows on the south side and none on the north. Now glass has improved and windows can be made with incredibly low U-values (meaning it doesn't let the cold through), so you can now have large glazed areas without heat loss. We need light and instinctively search for it. People move to the part of the room where there is natural light and children instinctively play in pools of light.

Light is what architecture is all about. It is as fundamental for the soul as air, fire, earth and water.

- most of contemporary life spent indoors, the quality of indoor environment is crucial for health and happiness of occupants
- the challenge is to design every space to have a sense of light and happiness
- a positive, light-filled space is healing for body, mind and spirit
- orientation of house for views and light, and to give each room its own character, the spirit of its surroundings, the state of being at home, an oasis of calm, protective and private, yet linked to nature and socially outward-looking.

Light has been one of the key elements of architecture since the Modern movement began (and glass technology improved) at the turn of the 20th century.

- improvements in glass technology have led to the widespread use of glass and new and inventive applications of glazing
- to maximise light, orientation has to be considered first – main elevation of house south facing, one room deep house – can be lighted and heated for most part by sunlight
- design existing houses to be considered for improved glazing – borrowing daylight through rooflights, light pipes, glass internal walling, fitting glazing to doors etc.
- open-plan design facilitates penetration of sunlight into centre of house
- sliding glass doors between rooms - can be opened to facilitate penetration of daylight and sunlight to rooms in the rear (north) of house. These doors can also be closed to provide visual and acoustic privacy in house when required
- sunrooms carefully designed and situated will greatly reduce energy requirements and reduce fossil fuel and bring natural daylight into building
- thermal mass to absorb, store and release solar heat as required, brise-soleil to prevent glare and reduce overheating.
- balance of white and dark surfaces, white surfaces to reflect light and provide light filled spaces

Yet, light has traditionally been lacking in Irish homes. Many old cottages only have windows on the south side and none on the north

- traditional single glazing lost much heat, windows were thus small and kept to a minimum
- because of historic window tax, windows kept to a minimum
- sliding sash windows had no draught proofing so were often draughty and cold and thus window size and numbers were kept to a minimum to avoid heat loss
- sun rises in east and sets in west, no sunshine in northern aspect, so many vernacular houses had no window on northern elevation.

Now glass has improved and windows can be made with incredibly low U-values (meaning it doesn't let the cold through), so you can now have large glazed areas without heat loss.

- major advance in glass technology low U-value from 0.8 to 0.4W/m²K
- glass can be cast, heated, coloured, tinted, curved
- modern glass manufactured with low iron content – reduced conductivity
- a wide range of glass now available such as safety glass, structural glass, laminated glass, glass with a self-cleaning coating applied
- glass roofs, doors, floors, partitions etc. are now possible with advancements in glass technology
- LEDs can be set within the layers of glass, to create coloured-glass kitchen splash backs
- fabrics, metals and digital images can be laminated within the body of glass
- dynamic glass is standard float glass with an electro-chromic coating applied on one of the surfaces and this coating automatically adjusts its tint in response to environmental conditions - eliminates the need for blinds or shades and achieves a reduction of up to 20% in energy consumption

- low emissivity (low-e) glass has a microscopically thin reflective coating applied to one surface. This coating allows the penetration of short heat waves of sun. When the interior heat energy tries to escape back to the colder outside during the winter, the low-e coating reflects the long wave solar infrared energy or heat back into the inside and thus reduces the radiant heat loss through the glass
- uncoated glass has an emissivity of 0.84 and low - e glass can have emissivity as low as 0.2
- vacuum glass has been developed for use in traditional historic houses where glazing bars cannot accommodate double or triple glazing, vacuum glass thickness as low as 6 mm
- houses can have large areas of glass, windows must be carefully positioned to maximise solar gain
- houses one room in depth - long house - with large glazing area on the southern elevation to capture maximum heat and light of the sun, no dark unheated spaces in house
- rooflight windows fitted on southern elevation to capture unobstructed heat and light of sun rooflights give even consistent daylight and can be up to three times more effective than regular vertical windows
- careful positioning of glazing reduces substantially need for artificial lighting and fossil fuel heating, leading to more sustainable living, doing far more with far less for far longer
- position room according to lifestyle, to maximise morning, noon and evening sunlight.

We need light and instinctively search for it. People move to the part of the room where there is natural light and children instinctively play in pools of light.

- architects study the micro-climate of a house and design to maximise daylight and sunlight, to give a house its essence
- we instinctively search for light, bedroom light to give optimism for day ahead, evening rooms to relax in, warm winter hearth and summer optimism and breeze-freshened openness
- sunlight for children home from school to bathe in and for adults to work in
- windows positioned for light and for views - for the invigoration of nature's moods, for skylscapes, for sunsets and for observing the changing quality of weather
- floor to ceiling glazing for maximum light and to capture views to outside
- a new paradigm to live sustainably, with design led solutions of best practice to build deep green, nearly zero energy buildings (NZEB) with minimum fossil fuel use for aesthetically pleasing, light-filled homes, having house with the lightest carbon footprint possible
- sustainability and environmental considerations at the heart of every design decision.

Three best practice guidelines that would encourage better use of natural light in the design of contemporary dwelling houses.... such as

- upgrade building regulations to make sustainability and NZEB a condition of planning
- incentivise people to refurbish and upgrade buildings to maximise the use of both natural daylight and sunlight
- publish deep green planning guidelines to be implemented for all housing developments which would highlight the benefits of natural light
- design flexible buildings to meet changing needs from birth to old age – lifetime use and universal design principles applied, plan for climate change and reduced use of electricity
- promote the design of buildings of modest scale, easy to heat, light and maintain through the considered location and sizing of fenestration
- focus on orientation and position of glazing in any new buildings
- focus on redesign of existing houses to upgrade thermal properties and to maximise daylight and sunlight for the health and wellbeing of all occupants – rooflights, internal glazing
- provide incentives to encourage sustainable design, grant aided a desirability
- education to highlight the importance of careful, considered design to deliver beautiful, light drenched and sustainable housing for all citizens
- education to focus on sustainability and energy use, with passive solar design at the core of the design process.

Any other relevant, cogent, well argued points.



Coimisiún na Scrúduithe Stáit
State Examinations Commission

Staidéar Foirgníochta

Teoiric – Ardleibhéal



Construction Studies
Theory – Higher Level

Marking Scheme

PERFORMANCE CRITERIA	MAXIMUM MARK
<i>Main entrance and door</i> <i>Any 11 points × 4 marks (Drawing 3, Annotation 1)</i>	
<ul style="list-style-type: none"> • Blockwork - deadwork • Hardcore with sand blinding • Radon barrier/DPM • Floor insulation • Subfloor and tile • Drainage channel • Level surface to drainage channel • High performance door – insulated (<i>standard door 2 marks</i>) • Doorframe - thermally broken and seals (<i>standard frame 2 marks</i>) • Lintels • Stepped DPC at head • Racking sheeting and strap • Breather membrane • Timber studs • Vapour diffusion cavity 50 – 100 mm • Concrete block external leaf and render • Fireproof cavity closer • Internal vapour barrier/taping - airtightness membrane • Service cavity • Plaster slab and skimcoat 	4 4 4 4 4 4 4 4 4 4 4 4 4 4 4 4 4
Draughting 4 marks <i>Excellent 4, Good 3, Fair 2)</i> Scale 4 marks	8
(b) Ease of access - sloped threshold and upstand	8
TOTAL	60

PERFORMANCE CRITERIA	MAXIMUM MARK
<i>(a) Three functional requirements of external wall (6 × 4 marks)</i>	
Requirement 1	4
Notes	4
Sketches	
Requirement 2	4
Notes	4
Sketches	
Requirement 3	4
Notes	4
Sketches	
<i>(b) Three different wall types (8 × 3 marks)</i>	
Wall type 1	3
Notes	3
Sketches	
Wall type 2	3
Notes	3
Sketches	
Wall type 3	3
Notes	3
Sketches	
Materials used (3 ×1 mark)	3
Typical dimensions (3 ×1 mark)	3
<i>(c) Evaluate design of any two walls (4 × 3 marks)</i>	
Evaluation - wall 1	3
Evaluation - wall 2	3
Recommendation for wall type	3
Justification for recommendation	3
TOTAL	60

PERFORMANCE CRITERIA	MAXIMUM MARK
(a) Extension A or Garden Room B	
Two advantages and two disadvantages of each option (8 × 3 marks)	
Option A Advantage 1	3
Advantage 2	3
Disadvantage 1	3
Disadvantage 2	3
Option B Advantage 1	3
Advantage 2	3
Disadvantage 1	3
Disadvantage 2	3
(b) External design, internal layout and link to garden (5 × 6 marks)	
External design - Notes	6
Sketches	6
Internal layout - Notes	6
Sketches	6
How proposed space is to link with rear garden	6
(c) Two advantages of linking space to rear garden (2 × 3 marks)	
Advantage 1	3
Advantage	3
TOTAL	60

PERFORMANCE CRITERIA	MAXIMUM MARK
(a) Discussion - eco-refurbishment - any two (2 × 10 marks)	
<ul style="list-style-type: none"> • Respect for local character • Breathable structure • Reuse of materials 	10 10
(b) Two areas for upgrading - roof, windows, floor (4 × 10 marks)	
<p>Area 1</p> <p style="padding-left: 40px;">Notes</p> <p style="padding-left: 40px;">Sketches</p> <p>Area 2</p> <p style="padding-left: 40px;">Notes</p> <p style="padding-left: 40px;">Sketches</p>	10 10 10 10
TOTAL	60

PERFORMANCE CRITERIA	MAXIMUM MARK
<i>(a) Insulated concrete ground floor (10 points × 3 marks)</i>	
Tabulation / methodology	3
External surface resistance	3
External render	3
External block	3
Polystyrene bead	3
Internal block	3
Internal plaster	3
Internal surface resistance	3
Total resistance	3
U-value (<i>1 mark for formula</i>)	3
<i>(b) Annual heat loss (10 points × 2 marks)</i>	
New house	2
Heat loss formula and calculation	2
Heating duration for one year	2
kJ calculation for one year	2
Litres of oil for one year	2
Annual cost of heat loss	2
Existing house	
Heat loss calculation	2
Heating duration for one year	2
kJ calculation for one year	2
Litres of oil for one year	2
Annual cost of heat loss	2
<i>(c) Prevent ingress of water at window head (2 × 5 marks)</i>	
Notes / annotations	5
Sketches	5
TOTAL	60

PERFORMANCE CRITERIA	MAXIMUM MARK
(a) <i>Low environmental impact design - three design features (6 × 5 marks)</i>	
<p>Design feature 1</p>	5
<p>Notes</p>	
<p>Sketches</p>	5
<p>Design feature 2</p>	5
<p>Notes</p>	
<p>Sketches</p>	5
<p>Design feature 3</p>	5
<p>Notes</p>	
<p>Sketches</p>	5
(b) <i>Any two design features (4 × 5 marks)</i>	
<p>Compact Form</p>	5
<p>Notes</p>	
<p>Sketches</p>	5
<p>Flexible design</p>	5
<p>Notes</p>	
<p>Sketches</p>	5
<p>Low maintenance</p>	5
<p>Notes</p>	
<p>Sketches</p>	5
(c) <i>Discussion of NZEB design for 21st century</i>	
<p>Discussion (<i>4 for point, 6 for discussion</i>)</p>	10
TOTAL	60

PERFORMANCE CRITERIA	MAXIMUM MARK
(a) Vertical section through roof structure - attic <i>Any 10 points × 4 marks (Drawing 3, Annotation 1)</i>	
<p>Wall</p> <p>400 mm external wall</p> <p>Full-fill cavity insulation</p> <p>Internal and external plaster/render</p> <p>Cavity closer</p> <p>100mm load-bearing centre wall</p> <p>Roof</p> <p>Wallplate</p> <p>Rafter</p> <p>Insulated slab to underside of rafter</p> <p>Vertical purlin</p> <p>Strut and collar</p> <p>Breather membrane and battens</p> <p>Counter battens</p> <p>Slates</p> <p>Fascia/soffit/gutter – (any 2)</p> <p>Ridge board</p> <p>Ceiling joist and 25mm tongue-and-groove floor boards</p>	<p>4</p> <p>4</p> <p>4</p> <p>4</p> <p>4</p> <p>4</p> <p>4</p> <p>4</p> <p>4</p> <p>4</p> <p>4</p> <p>4</p> <p>4</p> <p>4</p>
4 typical dimensions	4
<p>Scale and Draughting</p> <p>Draughting 4 marks <i>(excellent 4, good 3, fair 2)</i></p> <p>Scale 4 marks</p>	8
(b) Best practice design detailing to ensure ventilation (8 marks)	
Two design details for ventilation – eaves and roof/ridge <i>(4 + 4 marks)</i>	8
TOTAL	60

PERFORMANCE CRITERIA	MAXIMUM MARK
<i>(a) Design of zoned plumbing system (9 × 4 marks) (Sketches 3 Annotation 1)</i>	
Wood burning stove	4
Flow and return to radiators	4
Radiators	4
Zone control valves	4
Zone thermostats	4
Header / expansion / storage tank	4
Feeds to expansion tanks	4
Cold feeds from expansion tanks	4
Expansion pipes or expansion vessels	4
Primary flow and return	4
Pump and valves (radiator /isolating/ drain off - <i>(any 2)</i>)	4
Solar panel	4
Solar flow & return	4
Solar pump	4
Cylinder (twin coil)	4
Control panel	4
Expansion vessel	4
Thermal reducing vessel	4
Sizes of pipework <i>(any 2) (2 × 2 marks)</i>	4
<i>(b) Preferred location for solar collector (2 × 4 marks)</i>	
Notes	4
Sketches	4
<i>(c) Discuss location of chimney and hot press (2 × 6 marks)</i>	
Chimney <i>(Notes - 3 marks & sketches 3 marks)</i>	6
Hot press <i>(Notes - 3 marks & sketches 3 marks)</i>	6
TOTAL	60

PERFORMANCE CRITERIA	MAXIMUM MARK
(a) Thermal bridging details - Three locations (6 × 8 marks)	
<p>Location 1</p> <p>Notes</p> <p>Sketches</p> <p>Location 2</p> <p>Notes</p> <p>Sketches</p> <p>Location 3</p> <p>Notes</p> <p>Sketches</p>	<p>8</p> <p>8</p> <p>8</p> <p>8</p> <p>8</p> <p>8</p>
(b) Discussion - Thermal bridge free building envelope (12 marks)	
<p>Discussion (<i>point 1</i>) - 2 marks for point, 4 marks for discussion</p> <p>Discussion (<i>point 2</i>) - 2 marks for point, 4 marks for discussion</p>	<p>6</p> <p>6</p>
TOTAL	60

CEIST 10

PERFORMANCE CRITERIA	MAXIMUM MARK
(a) <i>Design of a Passive House - any 2 (4 × 8 marks)</i>	
<p>Airtight building envelope</p>	
<p>Notes</p>	8
<p>Sketches</p>	
<p>Space heating demand</p>	8
<p>Notes</p>	
<p>Sketches</p>	8
<p>Indoor air quality</p>	8
<p>Notes</p>	
<p>Sketches</p>	
(b) <i>Importance of thermal mass (2 × 7 marks)</i>	
<p>Notes</p>	7
<p>Sketches</p>	7
(c) <i>Carefully designed solar shading (2 × 7 marks)</i>	
<p>Design Details</p>	
<p>Notes</p>	7
<p>Sketches</p>	7
TOTAL	60

CEIST 10 (Alternative)

PERFORMANCE CRITERIA	
<i>Discussion of statement (3 × 8 marks)</i> <i>Advantages in glazing technology (6 marks)</i>	
Discussion – point 1 (<i>3 for point, 5 for discussion</i>)	8
Discussion – point 2 (<i>3 for point, 5 for discussion</i>)	8
Discussion – point 3 (<i>3 for point, 5 for discussion</i>)	8
Advances in glazing technology - increased use of glass	6
<i>Three guidelines on use of natural light (3 × 10 marks)</i>	
Guideline 1 (<i>4 for point, 6 for discussion</i>)	10
Guideline 2 (<i>4 for point, 6 for discussion</i>)	10
Guideline 3 (<i>4 for point, 6 for discussion</i>)	10
TOTAL	60



Coimisiún na Scrúduithe Stáit
State Examinations Commission

Scrúdú na hArdteistiméireachta 2015
Leaving Certificate Examination 2015

Scéim Mharcála
Marking Scheme
(150 marc)

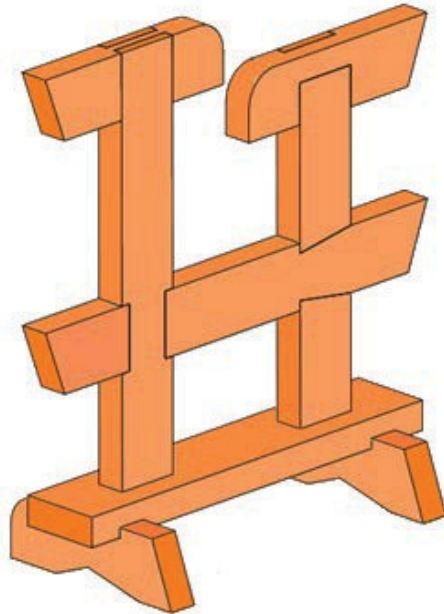

Staidéar Foirgníochta
Triail Phraticiúil

Construction Studies
Practical Test

Construction Studies 2015 Marking Scheme – Practical Test

Note:

The artefact is to be hand produced by candidates without the assistance of machinery. However the use of a battery powered screwdriver is allowed.

Where there is evidence of the use of machinery for a particular procedure a penalty applies.

Component is marked out of 50% of the marks available for that procedure.

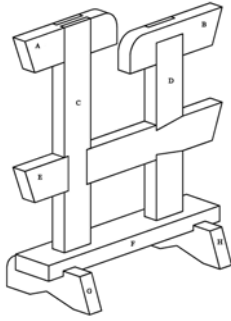
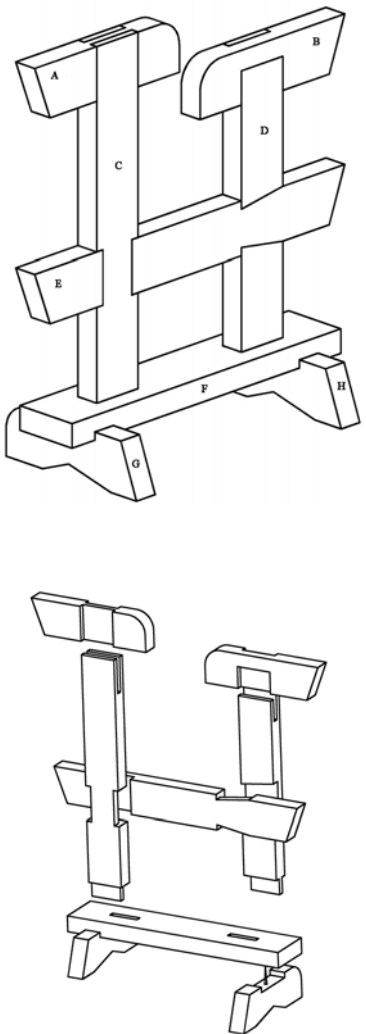
	(i)	OVERALL ASSEMBLY	MARKS
	1	Overall quality of assembled artefact	10
	2	Design and applied shaping to edges <ul style="list-style-type: none"> • design <i>(3 marks)</i> • shaping <i>(3 marks)</i> 	6
	Total		16
	(ii)	MARKING OUT	Marks
	1	Piece A <ul style="list-style-type: none"> • Bridle joint <i>(2 marks)</i> • slope and curve <i>(2 × 1 mark)</i> 	4
	2	Piece B <ul style="list-style-type: none"> • Bridle joint <i>(3 marks)</i> • slope and curve <i>(2 × 1 mark)</i> 	5
	3	Piece C <ul style="list-style-type: none"> • Bridle joint <i>(2 marks)</i> • Halving joint <i>(3 marks)</i> • Tenon <i>(3 marks)</i> 	8
	4	Piece D <ul style="list-style-type: none"> • Bridle joint <i>(3 marks)</i> • Dovetail joint <i>(3 marks)</i> • Tenon <i>(3 marks)</i> 	9
	5	Piece E <ul style="list-style-type: none"> • Halving joint <i>(2 marks)</i> • Dovetail joint <i>(4 marks)</i> • Slopes <i>(2 × 1 mark)</i> 	8
	6	Piece F <ul style="list-style-type: none"> • joints - mortices <i>(2 × 2 marks)</i> 	4
	7	Piece G and H <ul style="list-style-type: none"> • trenches <i>(2 × 2 marks)</i> • slopes and curves <i>(8 × 1 mark)</i> 	12
Total		50	

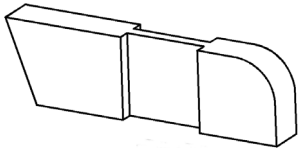
PIECE A	(iii)	PROCESSING	Marks
	1	Trenches <ul style="list-style-type: none"> sawing across the grain <i>(4 × 1 mark)</i> paring trench <i>(2 × 1 mark)</i> 	6
	2	Shaping <ul style="list-style-type: none"> sloped edge <i>(1 mark)</i> curve <i>(1 mark)</i> 	2
		Total	8

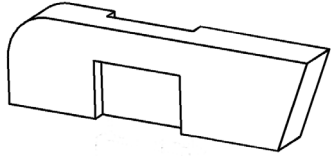
PIECE B	(iv)	PROCESSING	Marks
	1	Trench <ul style="list-style-type: none"> sawing across the grain <i>(4 × 1 mark)</i> paring trench on front <i>(3 marks)</i> paring trench on back <i>(1 mark)</i> 	8
	2	Shaping <ul style="list-style-type: none"> sloped edge <i>(1 mark)</i> curve <i>(1 mark)</i> 	2
		Total	10

PIECE C	(v)	PROCESSING	Marks
	1	Tenon <i>(5 marks)</i>	5
	2	Centre trenches <i>(3 × 2 marks)</i>	6
	3	Bridle joint <ul style="list-style-type: none"> sawing with grain <i>(2 × 1 mark)</i> paring trench <i>(2 marks)</i> 	4
		Total	15

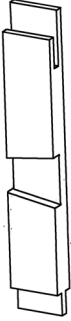
PIECE D	(vi)	PROCESSING	Marks
	1	Tenon <i>(5 marks)</i>	5
	2	Dovetail halving <ul style="list-style-type: none"> sawing slopes <i>(2 × 1 mark)</i> paring trench <i>(1 mark)</i> 	3
	3	Bridle <ul style="list-style-type: none"> sawing with grain <i>(2 × 1 marks)</i> sawing across the grain <i>(1 mark)</i> paring trench <i>(2 marks)</i> 	5
		Total	13

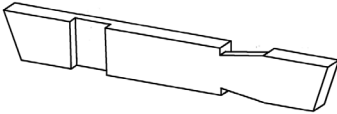
PIECE E	(vii)	PROCESSING	Marks
	1	Halving joint <ul style="list-style-type: none"> sawing across grain <i>(2 × 1 mark)</i> paring trench <i>(1 mark)</i> 	3
	2	Dovetail halving <ul style="list-style-type: none"> sawing across grain <i>(4 × 1 mark)</i> shaping slopes <i>(2 × 2 marks)</i> paring trench <i>(1 mark)</i> 	9
	3	Shaping sloped ends <i>(2 × 1 mark)</i>	2
		Total	14

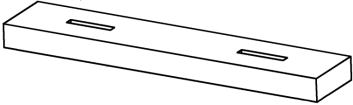
PIECE F	(viii)	PROCESSING	Marks
	1	Mortices <i>(2 × 3 marks)</i>	6
		Total	6

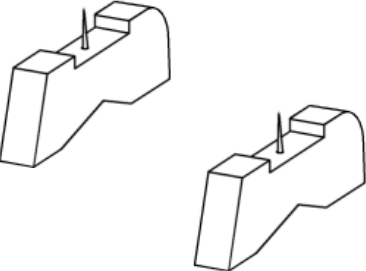
PIECES G and H	(ix)	PROCESSING	Marks
	1	Trenches <ul style="list-style-type: none"> sawing shoulders <i>(4 × 1 mark)</i> paring trench <i>(2 × 1 mark)</i> 	6
	2	Shaping slopes <i>(6 × 1 mark)</i> Shaping curves <i>(2 × 1 mark)</i>	8
	3	Drilling and countersinking screws <i>(2 × 2 marks)</i>	4
		Total	18

Blank Page

