

# FEDERATION OF THE DISCO PIMP

TECHNICAL SPECIFICATION - 2016

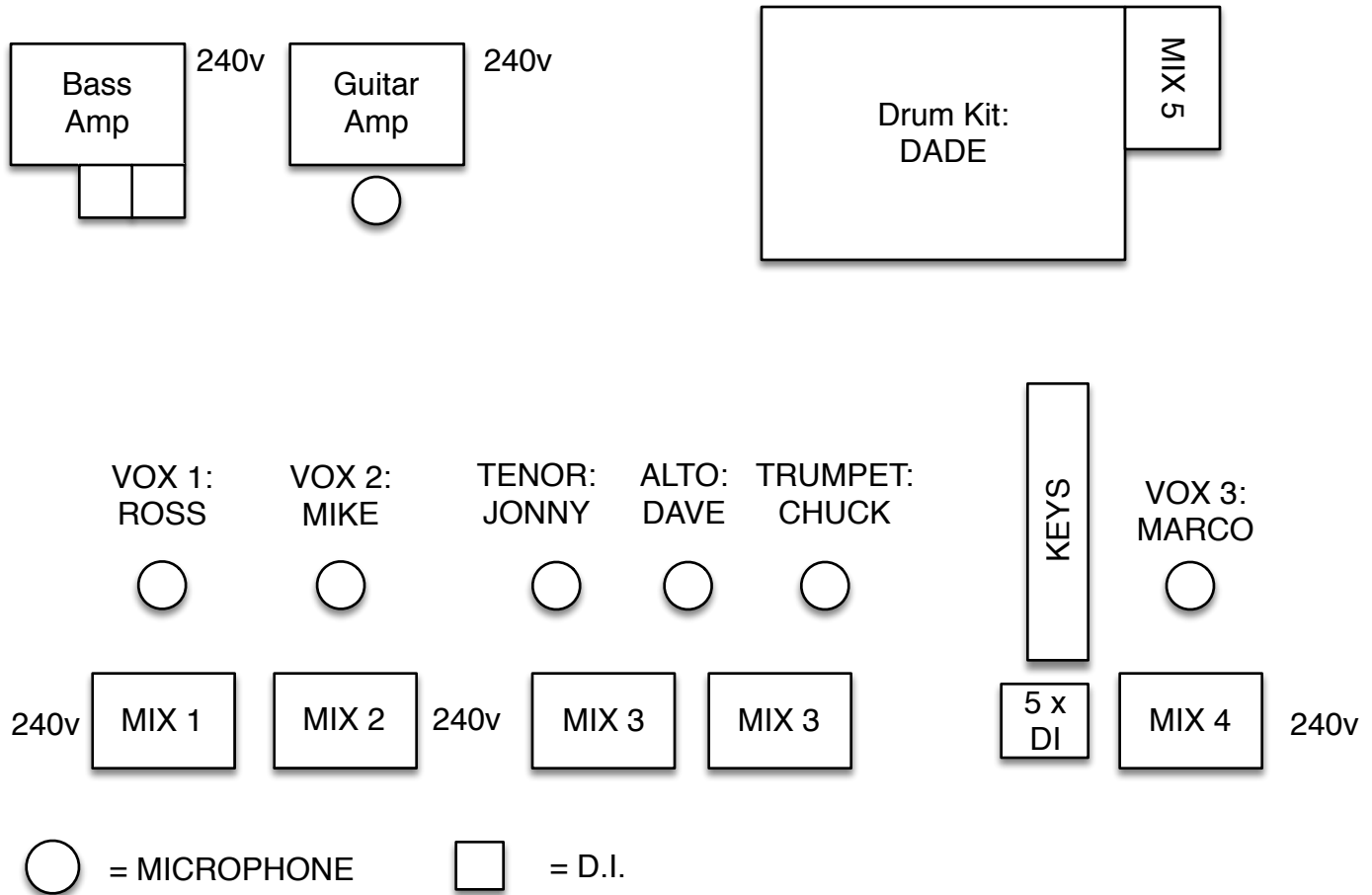

## P.A requirements:

A professional level system of reputable brand (D&B Audiotechnik, Logic Systems, L'Acoustic, Nexo etc), in full working order and arrayed to provide adequate dispersal for all audience members (including delays and in-fills where appropriate).

Minimum 5 gates (Drawmer DS201/DS404) and 6 compressors (dbx 160 or similar) for inserts at F.O.H, plus three outboard effects units - 2 x reverb and 1x delay. (PCM 91, TC M-ONE, SPX 990, D-2 or similar).

We require: 6 wedges over no less than 5 discrete mixes, each mix with it's own 31 band graphic EQ inserted. Additional wedges and sidefill where appropriate. Again wedges should be of a reputable brand and in full working order.

If any of this is not possible please contact us as soon as possible with alternatives. Thanks for your help and we look forward to working with you.

| No. | CHANNEL  | DESCRIPTION      | MIC/DI                                  | INSERT |
|-----|--|------------------|---|--------|
| 1   | KICK IN  | + 48V            | BETA 91                                 | GATE   |
| 2   | KICK OUT   | SHORT BOOM STAND | M88/BETA 52                             | GATE   |
| 3   | SNARE TOP  | SHORT BOOM STAND | BEYER 201/BETA 57                       |        |
| 4   | SNARE UNDER  | SHORT BOOM STAND | SM 57                                   | GATE   |
| 5   | HI HAT   | SHORT BOOM STAND | AKG 451 / SM 81                         |        |
| 6   | SNARE 2 ('CYMBAL ON TOP' EFFECT)                                   | SHORT BOOM STAND | BETA 57 / SM 57                         | GATE   |
| 7   | RACK TOM   | CLIP             | BETA 98 / e604                          | GATE   |
| 8   | FLOOR TOM  | CLIP             | BETA 98 / e604                          | GATE   |
| 9   | OH LEFT  | TALL BOOM STAND  | C 414                                   |        |
| 10  | OH RIGHT   | TALL BOOM STAND  | C 414                                   |        |
| 11  | BASS (CLEAN)   | XLR              | RADIAL JDI<br>(SUPPLIED BY BAND)        | COMP   |
| 12  | BASS (DIRT/EFFECTS - DELAY/PHASE<br>ADJUST CHANNEL PLEASE. THANKS) | XLR              | GK 700RBII AMP DI<br>(SUPPLIED BY BAND) |        |
| 13  | GUITAR AMP   | SHORT BOOM STAND | e906/e609/SM 57                         |        |
| 14  | NORD STAGE 2 - Ch.1 - LEFT<br>(Rhodes / Organ /Piano)              | XLR              | D.I                                     |        |
| 15  | NORD STAGE 2 - Ch.2 - RIGHT<br>(Rhodes / Organ /Piano)             | XLR              | D.I                                     |        |
| 16  | NORD STAGE 2 - Ch.3 - (Distorted<br>Clavinet)                      | XLR              | D.I                                     |        |
| 17  | NORD STAGE 2 - Ch.4 - (Samples)                                    | XLR              | D.I                                     |        |
| 18  | MOOG   | XLR              | D.I                                     |        |
| 19  | TENOR SAX  | TALL BOOM STAND  | BETA 57/BETA 58                         | COMP   |
| 20  | ALTO SAX   | TALL BOOM STAND  | BETA 57/BETA 58                         | COMP   |
| 21  | TRUMPET  | TALL BOOM STAND  | BETA 57/BETA 58                         | COMP   |
| 22  | VOCAL 1 (GROUP VOCS)   | TALL BOOM STAND  | SM 58                                   | COMP   |
| 23  | VOCAL 2 (GROUP VOCS / LEAD)  | TALL BOOM STAND  | SM 58                                   | COMP   |
| 24  | VOCAL 3 (SPEAKING ONLY)  | TALL BOOM STAND  | SM 58                                   |        |

FOTDP CONTACT: - MARCO CAFOLLA - +44(0)7763911251  
e: - marco\_9@msn.com