

REVISIONS			
REV.	DESCRIPTION	DATE	APPROVED
A.01	INITIAL DRAFTING AND LAYOUT.	16 MAR 2016	D ROLLINSON
A.02	ADDED MISSING DIMS ON BOTTOM VIEW	23 MAY 2016	D ROLLINSON

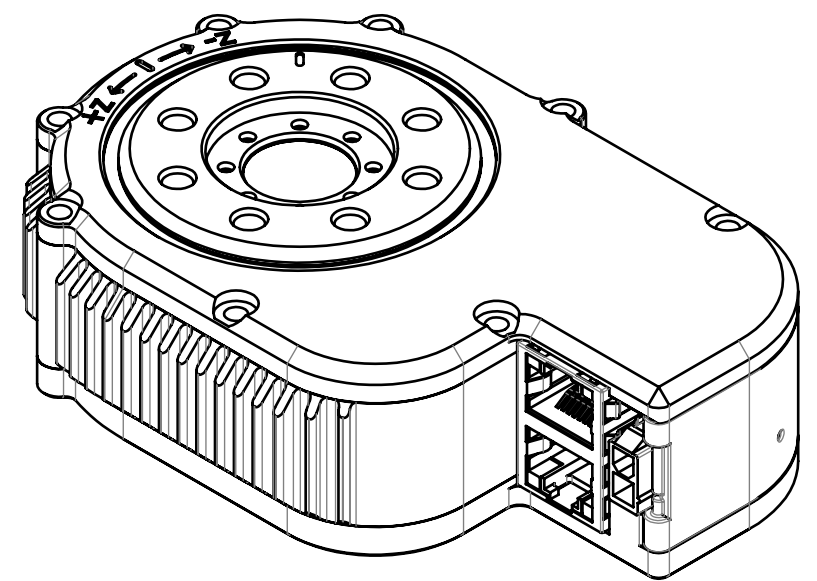
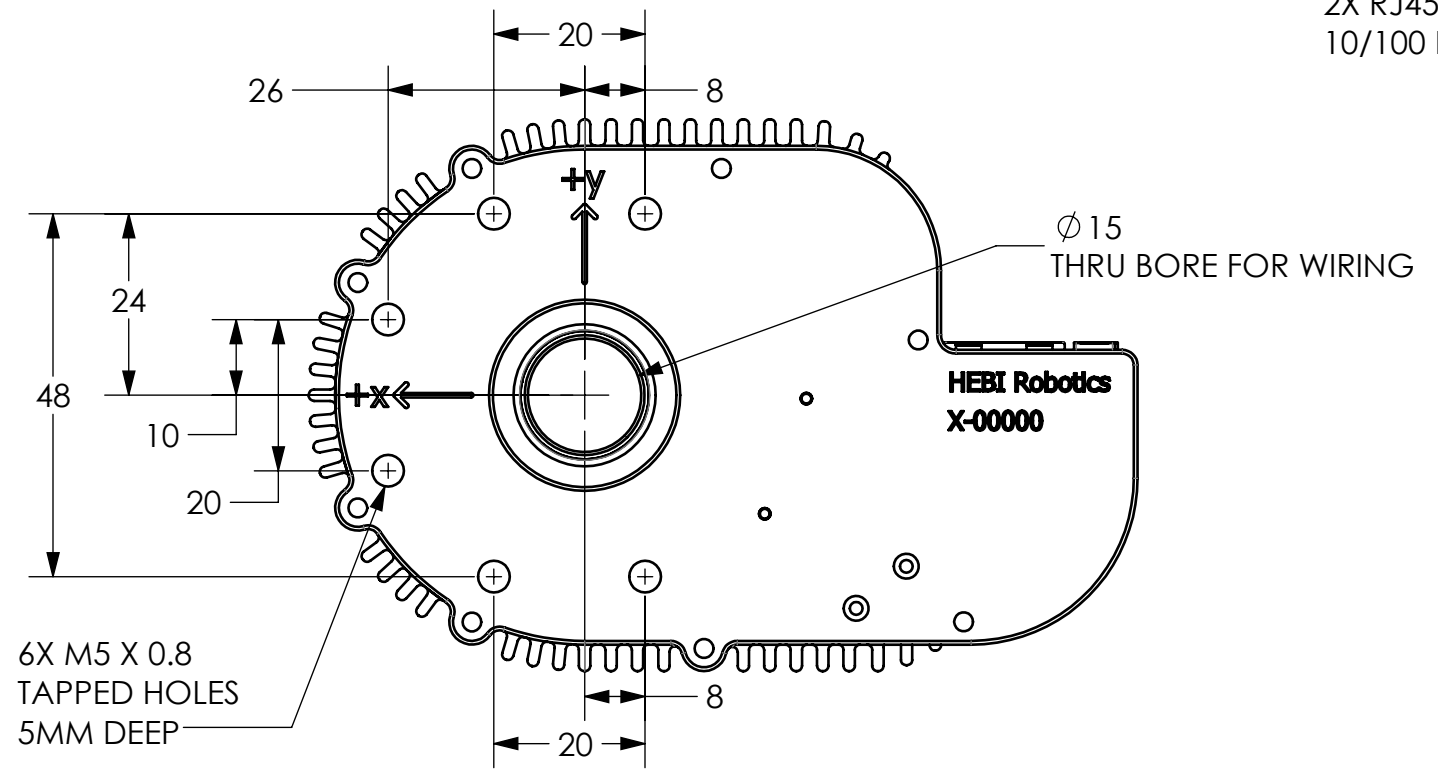
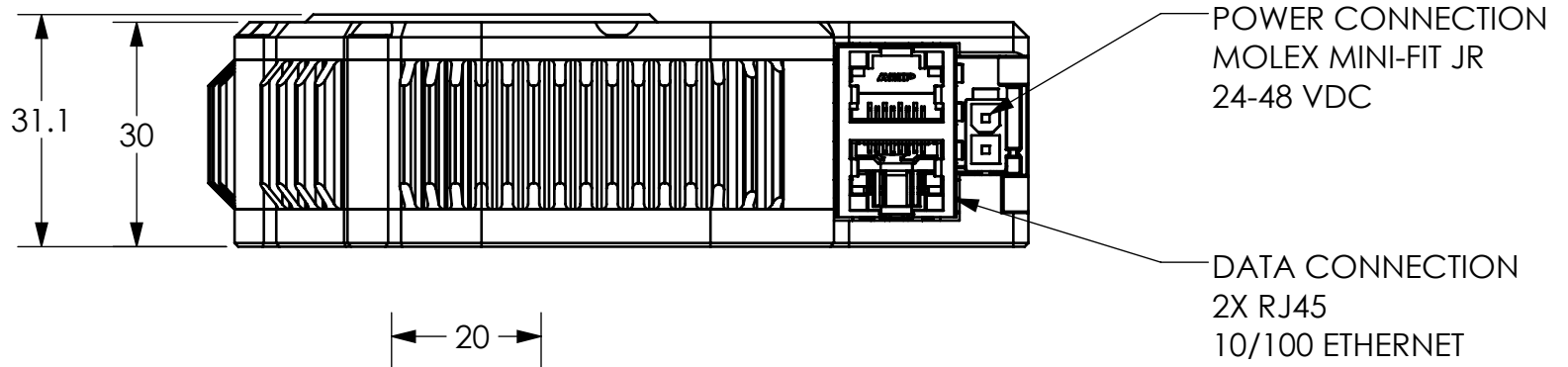
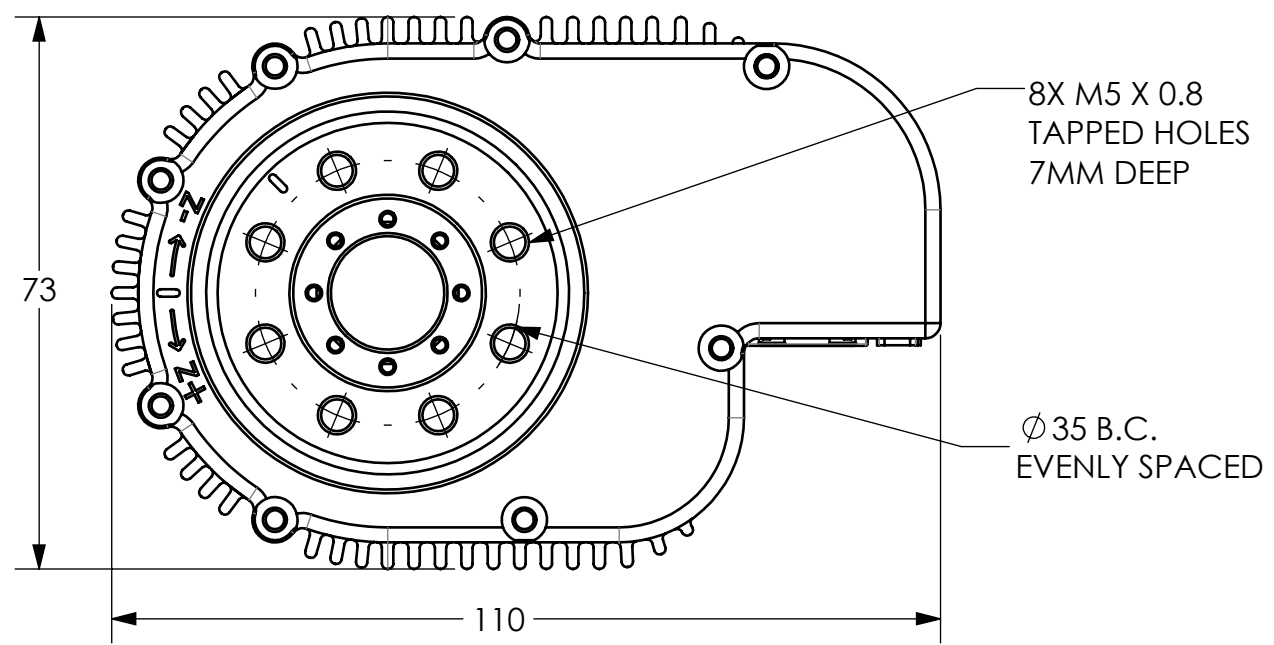

AUTHORIZATION		HEBI ROBOTICS, LLC	
DFTG:		5001 Baum Blvd, Suite 780 Pittsburgh, PA 15213	
DSGNR:		PROJECT: X-Series Actuator	
CHKR:		X5 Actuator Dimensions	
ENGR:		SIZE B X5-Dimensions REV A.02 VER	
UNLESS OTHERWISE SPECIFIED DIMENSIONS ARE IN MM DO NOT SCALE DRAWING		SCALE: 1:1	WEIGHT:
TOLERANCES:	X.X ±.30 X.XX ±.08 ANGLES ±1.00°	SHEET 1 OF 1	

THE INFORMATION CONTAINED IN THIS DRAWING IS THE SOLE PROPERTY OF HEBI ROBOTICS, LLC. ANY REPRODUCTION IN PART OR WHOLE WITHOUT WRITTEN PERMISSION OF IS PROHIBITED.