

REVISIONS			
REV.	DESCRIPTION	DATE	APPROVED
A.01	INITIAL DRAFTING AND LAYOUT.	15 JUN 2016	D ROLLINSON

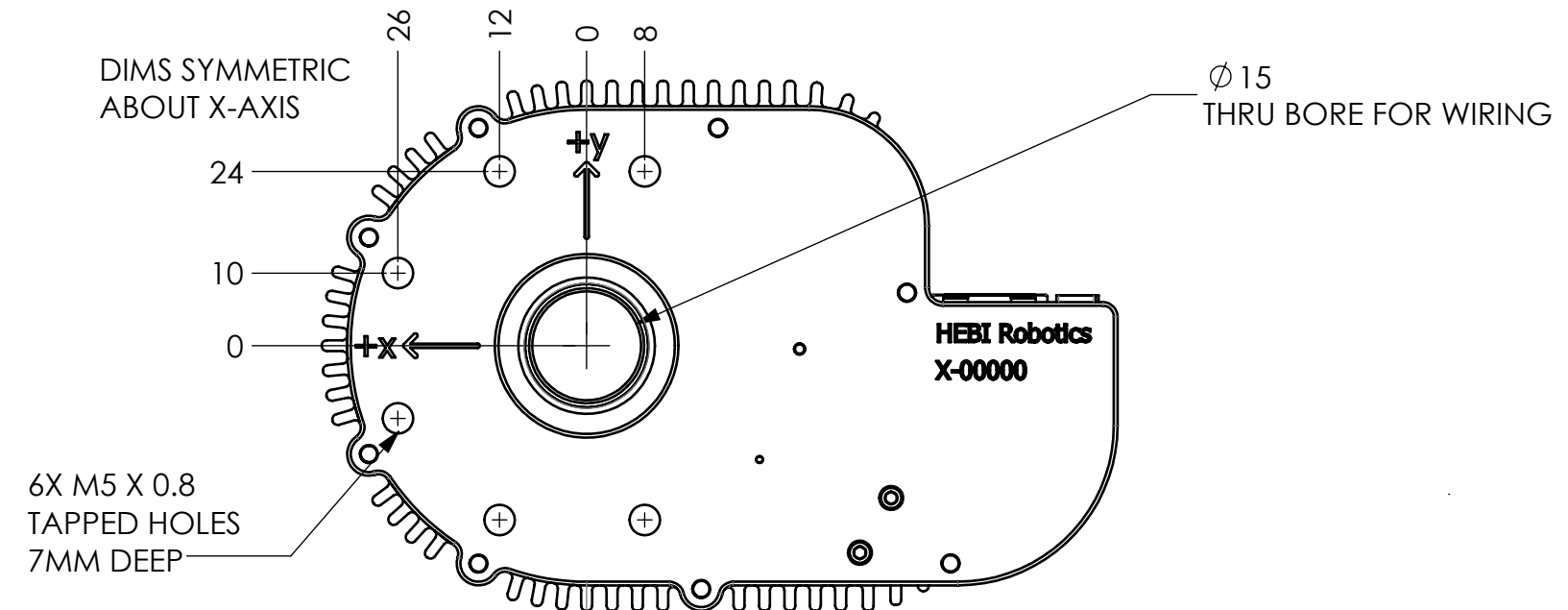
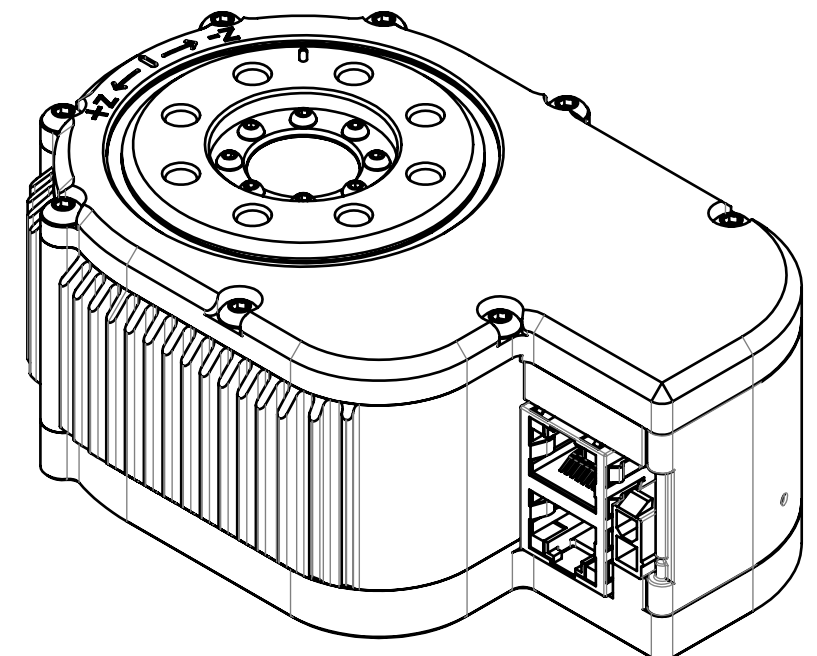
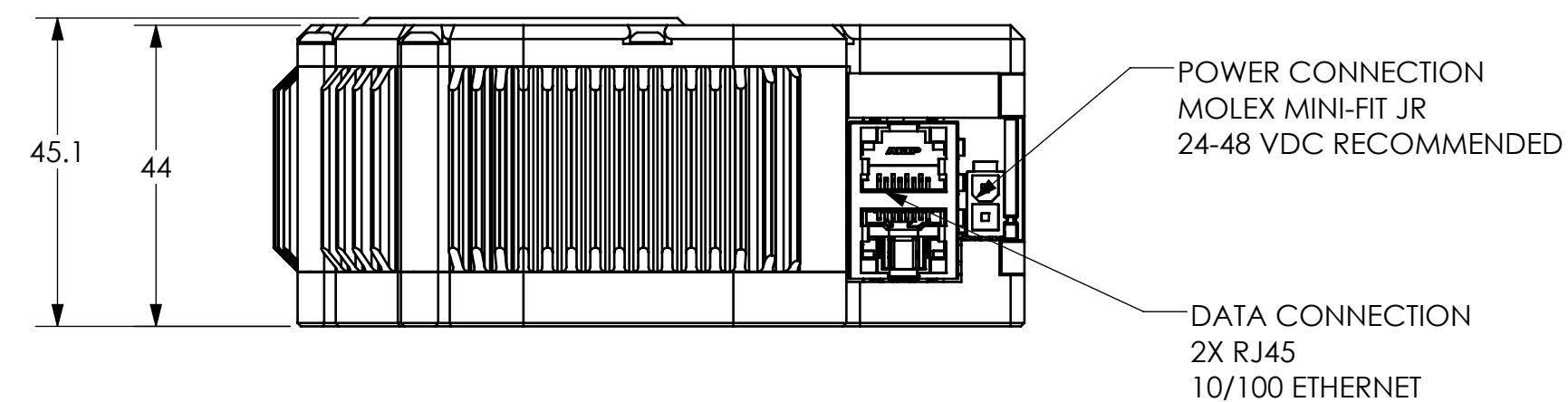
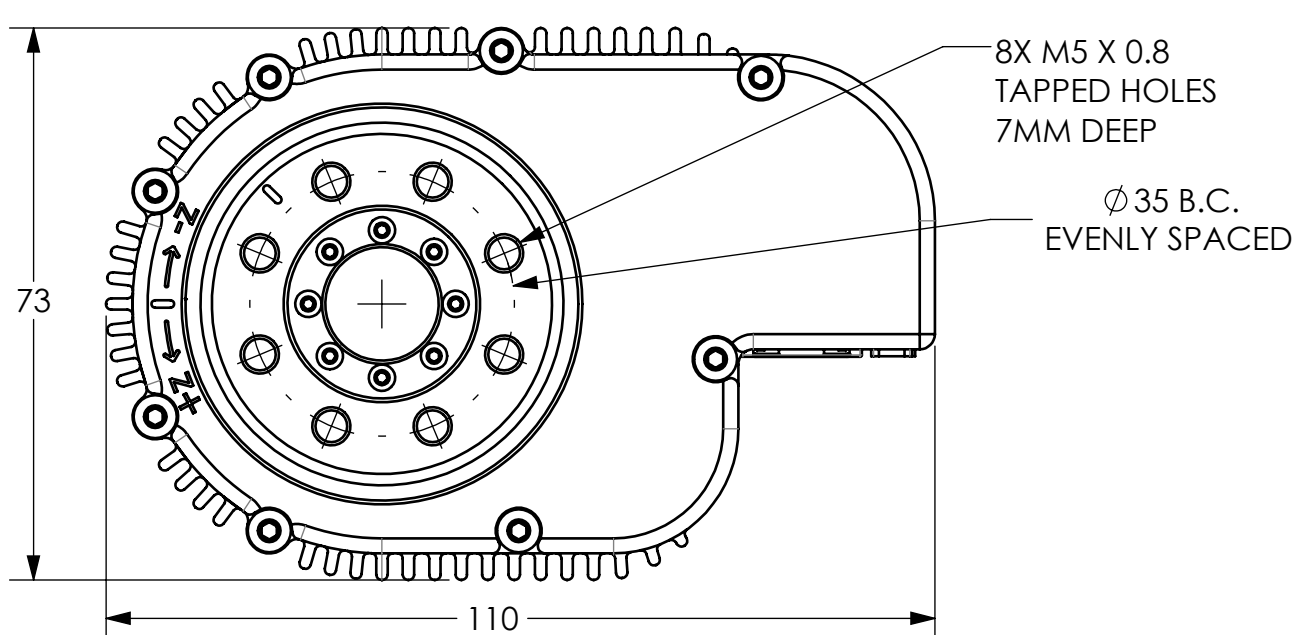

AUTHORIZATION		HEBI ROBOTICS, LLC	
DFTG:		5001 Baum Blvd, Suite 780 Pittsburgh, PA 15213	
DSGMR:		PROJECT: X-Series Actuator	
CHKR:		X8 Actuator Dimensions	
ENGR:		UNLESS OTHERWISE SPECIFIED DIMENSIONS ARE IN MM DO NOT SCALE DRAWING	
TOLERANCES:		X.X	±.30
	X.XX		±.08
	ANGLES		±1.00°
SIZE	B X8-Dimensions	REV	VER
SCALE:	1:1	WEIGHT:	SHEET 1 OF 1

THE INFORMATION CONTAINED IN THIS DRAWING IS THE SOLE PROPERTY OF HEBI ROBOTICS, LLC. ANY REPRODUCTION IN PART OR WHOLE WITHOUT WRITTEN PERMISSION OF IS PROHIBITED.