

# **HED Supercapacitor**

## **Data Sheet**

**Model: AM100F3V**

**May 2016**

## Contents

1	Amperics Module Code Number.....	3
2.	Test Conditions and Standards.....	3
2.1	Test Conditions.....	3
2.2	Test Standard.....	3
3.	Main Technical Parameters.....	3
3.1	IEC Standard Test Method Details.....	4
3.2	Maxwell Six-Step Test Method.....	4
4.	Size.....	5
4.1	Dimensions.....	5
4.2	Supercapacitor Diagram.....	5
5.	Product Performance.....	5
6.	Lifetime Characteristics.....	6
7.	Safety.....	7

1. **Amperics Module Code Number**

AM100F3V

2. **Test Conditions and Standards**

2.1 **Test Conditions** The testing for this specification was performed under normal room temperature (25 °C) and humidity (<65% RH). These specifications are valid with  $\pm 20\%$  performance for temperatures (-30 – 65 °C) and humidity (<95% RH).

2.2 **Test Standard** IEC 62391-1 (Industry standard including Maxwell)

3. **Main Technical Parameters**

<i>Item</i>	<i>Specification</i>	<i>Remarks</i>
Rated Capacitance	100 F	IEC 62391-1 (see next page)
Capacitance Tolerance	$\pm 20\%$	
Rated Voltage	3.0 V	
Maximum Voltage	3.2 V	
ESR <sub>DC</sub>	8 mΩ	IEC 62391-1 (see next page)
Max working current	8.0 A	
Max leakage current (72 h)	0.3 mA	
Max peak current	60 A	Max discharge current in 1 second
Storage Energy	0.12 Wh	
Energy Density	6.0 Wh/KG	
Temperature Range	-40 °C to 65 °C	
Storage	-40 °C to 65 °C	
Weight	20 g	

**3.1 IEC Test Method** Charge under constant current to rated voltage, then charge under constant voltage. After 10 mins of constant voltage, discharge under constant current. Record voltage to  $U_1$ ,  $U_2$  and their respective  $t_1$  and  $t_2$ . The Capacitance is calculated as

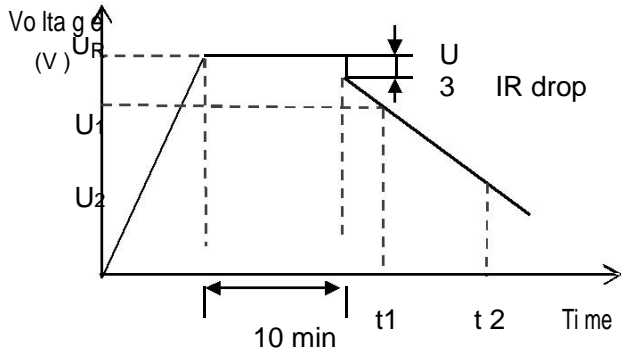

Capacitance formula: 
$$C = \frac{I \times (t_2 - t_1)}{U_1 - U_2}$$

$I$  :  $D$  is charge current,  $4 \times C \times U_R$  (mA)

$U_1$  : Initial voltage,  $0.8 \times U_R$  (V);

$U_2$  : Ending voltage,  $0.4 \times U_R$  (V);

$t_1$  : Time from discharge start to initial voltage  $U_1$  (s)

$t_2$  : Time from discharge start to ending voltage  $U_2$  (s)

Chart 1: Voltage time characteristics

### 3.2 Maxwell Six-Step Test Method

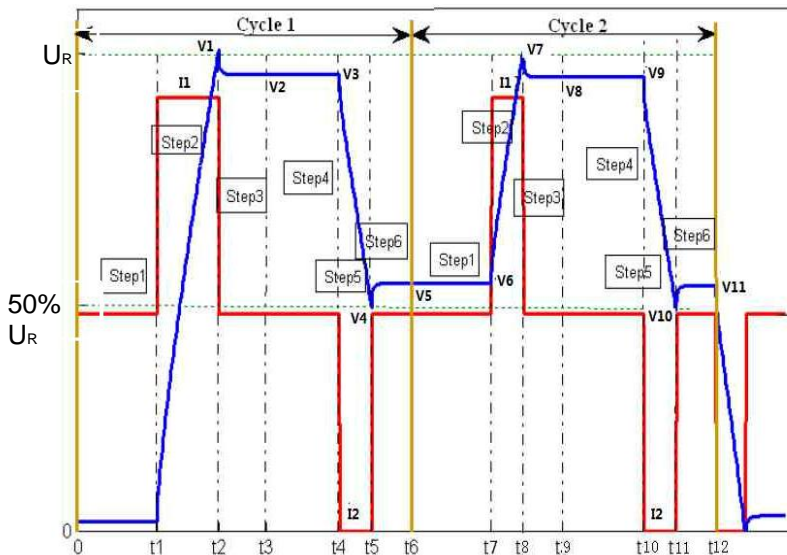

Test Steps:

step1: Rest 10s;

step2: Charge under constant current ( $I_1$ ) to rated voltage ( $U_R$ )

step3: Rest 5s;

step4: Rest 10s, record  $V_3, t_4$

step5: Discharge under constant current ( $I_2$ ) to 1/2 rated voltage  $U_R$ , record  $I_2, V_4, U_R, t_5$

step6: Rest 5s, record  $V_5, t_6$

Repeat step1~step6, and record current, voltage, time,

finally discharge to below 0.1V under constant current ( $I_2$ )

Parameters Calculations:  $C_{dish1} = I_2 \times (t_5 - t_4) / (V_3 - V_4)$ ;  $C_{dish2} = I_2 \times (t_{11} - t_{10}) / (V_9 - V_{10})$

Discharge Capacitance:  $C_{disch} = (C_{dish1} + C_{dish2}) / 2$

2 Time Cycle Discharge DC resistance (ESR) =  $(V_5 - V_4) / I_2$ ;  $ESR_{disch2} = (V_{11} - V_{10}) / I_2$

Energy:  $E = [1/2 \times C \times (U_1^2 - U_2^2)] / 3600$  where  $E$  is in Wh;  $C$  = Capacitance in F;

$U_1$  = rated voltage in V;  $U_2 = 1/2 \times U_1$  in V.

## 4. Size

### 4.1 Dimensions

D	18.0 mm ( $\pm 1.0$ )
L	60.0 mm ( $\pm 2.0$ )
d	0.8 mm ( $\pm 0.1$ )
P	8.0 mm ( $\pm 0.1$ )

### 4.2 Supercapacitor Diagram

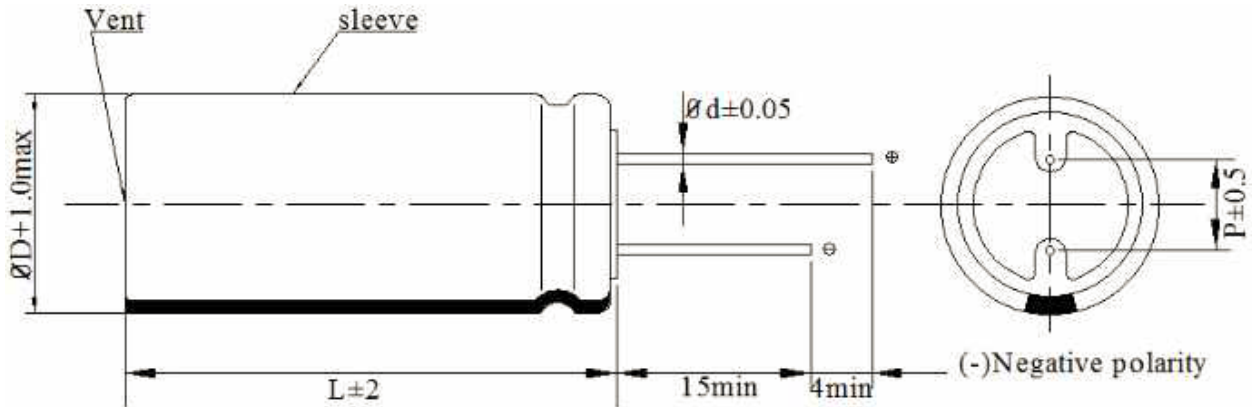

## 5. Product Performance

NO.	Item	Standard	Test Method
1	High temperature Life	$ \Delta C/C  \leq 20\%$ ESR $\leq 2$ times of initial value (25°C)	The capacitors storage 1500 + 48/-0 hours at rated voltage at $65 \pm 2^\circ\text{C}$ , Capacitance & ESR meet the standard, with no visible damage, no leakage, test method as previously stated.
2	Room temperature Life	$ \Delta C/C  \leq 20\%$ ESR $\leq 2$ times of initial value (25°C)	Work 10 years at rated voltage at 25°C
3	Storage Life	2 years	Max. storage temperature
4	Cycle Life	$ \Delta C/C  \leq 20\%$ ESR $\leq 2$ times of initial value (25°C)	50,000 cycles between rated voltage and half rated voltage under constant current at 25°C
5	Temperature characteristics	-40°C $ \Delta C/C  \leq 5\%$ ESR $\leq 2$ times of initial value (25°C)	Storage 12 hours under no-load condition
		65°C $ \Delta C/C  \leq 5\%$ ESR $\leq 2$ times of initial value (25°C)	

## 6. Lifetime Characteristics

ITEM		Features
Cycle Life	Test Methods	Capacitors cycles charge and discharge between specified voltage and half rated voltage under constant current at +25°C (50,000 cycles).
	Capacitance Change	≤20% of initial measured value
	Internal Resistance	≤2 times of initial specified value
Lifespan	Shelf life	After 1000 hours storage at the range of the rated temperature upper limit, without load, the capacitor shall meet the following specified limits for endurance
	Endurance	After 1000 hours application of rated voltage at the range of the rated temperature upper limit, the capacitor shall meet the following limits
	Life Test	After 10 years application at rated voltage, at +25°C, the capacitor shall meet the following limits
	Capacitance Change	≤30% of initial measured value
	Internal Resistance	≤2 times of initial specified value
Temperature Characteristics	Test Condition	at -40°C, +25°C, +65°C
	Change Capacitance	≤30% of initial measured value
	Internal Resistance	≤2 times of initial specified value
Damp heat Characteristics	Test Methods	Temperature: +40±2°C, humidity: 90~95% RH, After 240 hours storage, the capacitor will meet the following limits.
	Capacitance Change	≤30% of initial measured value
	Internal Resistance	≤2 times of initial specified value
Voltage Keep capability	Test Condition	At room temperature, charge 8 hours under constant rated voltage, and rest for 24 hours, the voltage shall meet standards.
	Voltage Change	≥80%*VR

## 7. Safety Considerations

- 7.1 The HEDS device has fixed polarity. Incorrectly connecting the terminals may cause destructive damage to the device.
- 7.2 The HEDS device should be never be used at voltages in excess of 3.2V: Voltages in excess of 3.2V may cause electrolyte decomposition, heating, permanent degradation of capacitance, internal resistance, lifetime, and in some cases destructive breakdown.
- 7.3 The HEDS device should not be stored in environments with over 85% Relative Humidity or be exposed to toxic gases as such exposure might lead to corrosion, and a short circuit condition
- 7.4 The HEDS device should be stored in the environment within the following conditions a) 30°C~50°C temperature and b) less than 60% Relative Humidity;
- 7.5 If the HEDS devices are applied on the double-side PCB, the connection should not be around the palce where the super capacitor can contact, because of the super capacitor installation, could lead to short circuit phenomenon;
- 7.6 When the making connections to the HEDS device onto a PCB, care must be taken to ensure that connector material does not infiltrate into the threading hole of the circuit board, as that may affect cap performance.
- 7.7 Using HEDS in series requires care as balancing the system becomes a critical issue. If there are any issues, it is recommended that Amperics advice be used.