



HARKNESS SCREENS™  
SMART-VIEW

GLOBAL LEADERS IN  
SCREEN TECHNOLOGY

# SMART-VIEW STYLISH SIMPLICITY

The use of projection technology to showcase movies, products, services and creative content is soaring in popularity. The importance of investing in a high quality, accomplished product is crucial when opting for a projection screen system, as these are part of the solution that will help professionally convey your message and ensure the best possible presentation quality.

For the highest quality boardroom, exhibition, display and presentation projects, Smart-View screen solutions from Harkness Screens offer unlimited possibilities for 2D and 3D, front and rear projection.

Founded in 1929, Harkness Screens is the world's leading screen technology company. With state-of-the-art manufacturing facilities worldwide, Harkness has consistently produced a superior class of projection screens on a global scale for use within a diverse range of environments from professional cinema through to home cinema, live events, concerts, exhibitions and theme park rides.

Smart-View, the fixed-frame screen technology from Harkness is a fuss-free, low maintenance system which can either be free-hanging, built in to a set, hung from a truss frame or mounted flush to the wall.

Durable, yet lightweight, Smart-View technology encompasses a black powder coated non-reflective extruded aluminium frame (which can be finished in black velour) and easily attachable screen surface. The two elements combine to create a screen solution that is quick to assemble suitable for home cinema, office boardrooms, preview theatres, live events, theme parks, art galleries and photo studios.

Stylish and sleek, Smart-View appeases every viewing requirement, providing a perfectly flat viewing surface. Smart-View is a simplistic, yet professional system that makes a striking centrepiece for any situation. With the correct projection setup, Smart-View screens can provide a platform for displaying flawless imagery in 2D or 3D.

Each Smart-View screen is custom made, available in a range of sizes up to 5.5m x 5.5m in either 16:9 (full HD) or 4:3 format however screens can be made to any format required.

The bespoke product allows for complete flexibility, with a range of front and rear projection surfaces available including Matt Plus and Perlux Digital for front projection 2D and active 3D surfaces, Spectral and Clarus XC for front projection polarised 3D surfaces and Harkness' industry leading Translite range for 2D and 3D rear projection surfaces.



Smart-View  
Commercial



Smart-View  
Professional

All of Harkness' front and rear projection screen surfaces can be perforated to allow for speaker placement behind the screen.

With typically quick manufacture and delivery times, all Smart-Views are delivered in a tube, complete with frame, fixing rail and choice of surface made to order.

For a powerful projection product that can truly impart a high quality viewing experience, Smart-View fixed frame screens can provide an unparalleled presentation solution. Easy to assemble and extremely reliable, particularly at the crucial moment be it an important product presentation or producing an immersive 3D environment for design and construction review, Smart-View will provide guaranteed quality.



# SCREEN SURFACE OPTIONS

Smart-View is available in a wide range of perforated and non-perforated surfaces, suitable for 3D/ 2D and front or rear projection. The Smart View is produced flat packed with surface choice. Fixing rail supplied.

	FRONT PROJECTION 2D/ ACTIVE 3D	FRONT PROJECTION 2D/ PASSIVE (POLARISED) 3D	REAR PROJECTION 2D	REAR PROJECTION 2D/ PASSIVE (POLARISED) 3D
Perforated or Non-Perforated	Matt Plus Matt Preview Perlux Digital 140 Perlux Digital 180 Perlux Digital 220	Spectral 240 Spectral 300 Clarus XC 140 Clarus XC 170 Clarus XC 220 Clarus XC 270		
Non-Perforated Only		Stagelite Stereo	Translite White Translite Cream Translite Grey Translite Blue Translite Midnight	Translite Stereo

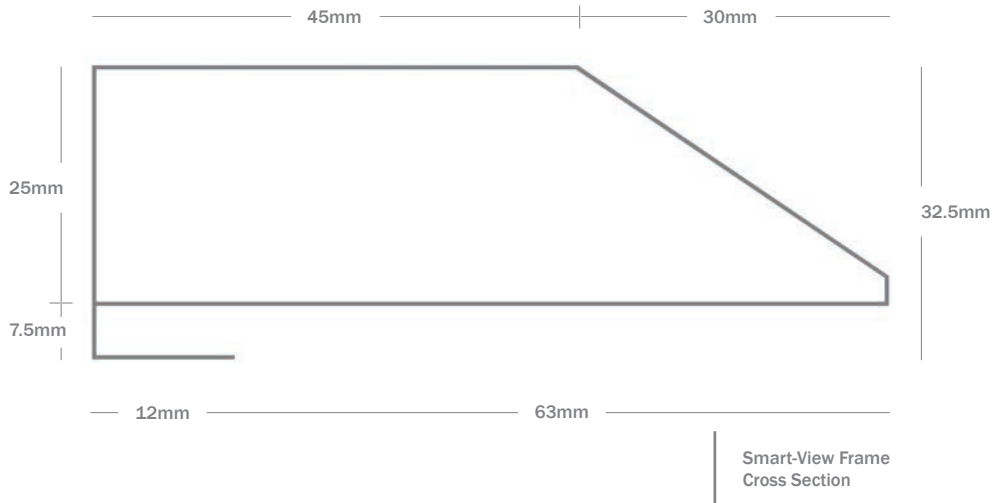

All Smart-View screen sizes are tailored to requirements. Small, intermediate and larger sizes available, maximum image size of 550cm x 550cm. Frame size is 15cm more than image size.\*\*

All Smart-View products are made to order; please find attached pricing guidelines.

\*\*Please note, velour material frames incur additional costs.

\*\*Any screen format available on request.