

# WOOD WINDOW REPAIR WORKSHOP

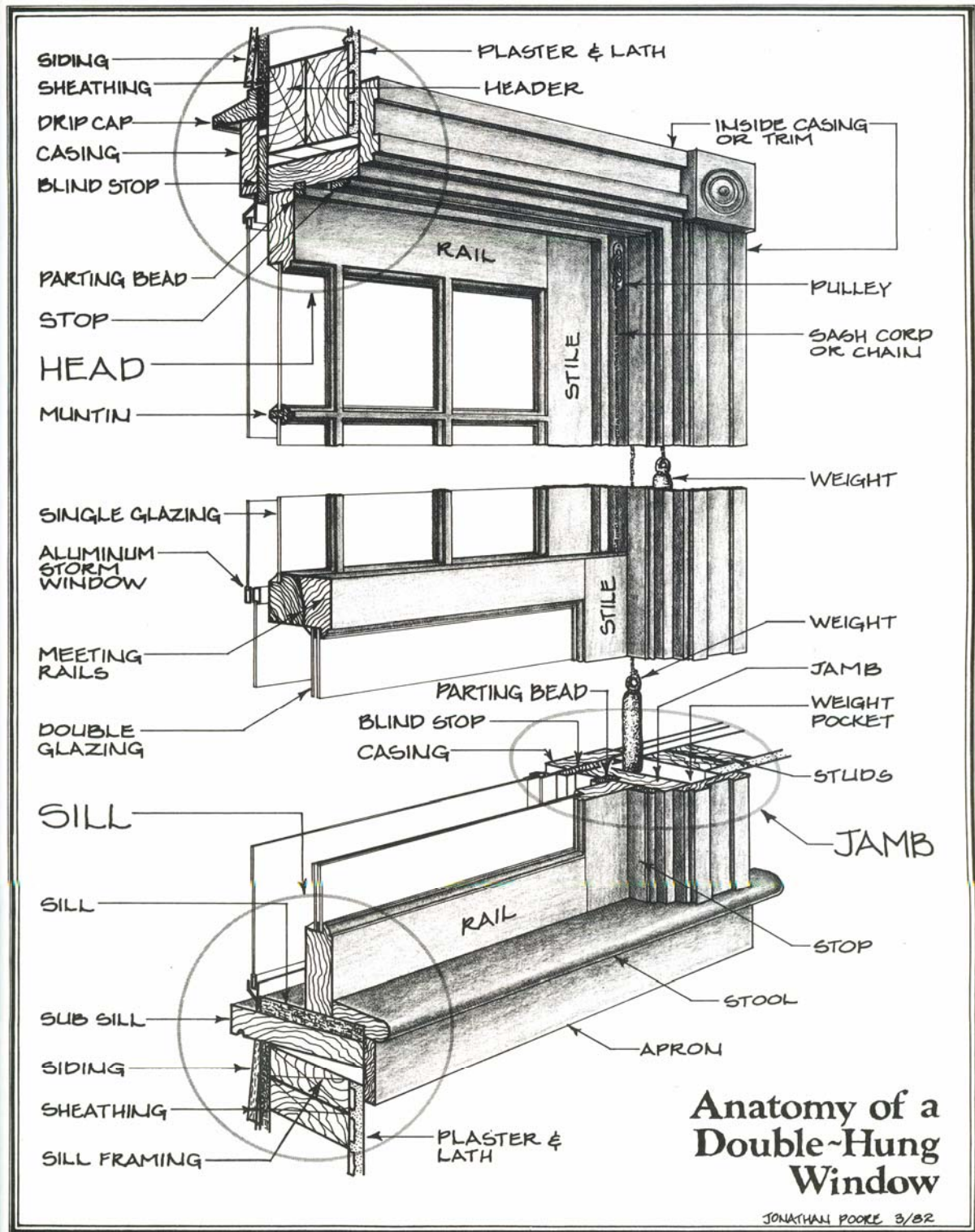

Presented by **LANDMARK CONSULTING**  
*Restoration Planning and Architectural Services*

83 Grove Avenue, Albany NY 12208 ☐ 518.458.8942 ☐ kkalvarez@landmarkconsulting.net

## Wood Window Repair Workshop

The Basics will cover:

- 1) How to remove a window sash from the frame
- 2) Repair broken cords
- 3) Replace broken glass or glazing putty
- 4) How best to strip paint
- 5) What tools to use
- 6) How to add weatherstripping

### **Purpose**

Generally the reasons for needing to repair or restore your wood windows are both structural and economical. Your window is most likely structurally sound (as most windows should be well into 100 years of use), but it may have many layers of paint, some cracked or missing putty on the exterior, broken sash cords or a cracked pane of glass. Because they are otherwise in good shape, it doesn't make sense to throw them out or replacement, simply because of a broken pane or cord. That would be a true waste of money. This workshop will tell you how to address and repair one or all of these symptoms, saving you money and allowing you to retain your historic wood windows for another 100 years.

### Introduction: Understanding the origins and mechanics of your wood double hung window

The double hung sash window was introduced as an improvement of the earlier hinged casement window. These double hung windows were first introduced in England in the early 1700s, but consisted of many small panes of glass given the unavailability of methods for producing large panes of glass. These small panes of glass were held within a larger frame by a small web of framing members called "muntins". You can often date historic windows both by noting the size of glass panes as well as the number and shape of the muntins. Windows are often described by the number of panes – for example if a window has six panes in the upper sash and only one in the lower sash it is described as "a six-over-one double hung sash" or "6/1 DH sash." As the manufacturing of glass improved in this country, windows changed from 12-over-12 DH to 9-over-9, to 6-over-6, to 2-over-2 and even 1-over-1 in the late 19<sup>th</sup> century. In the

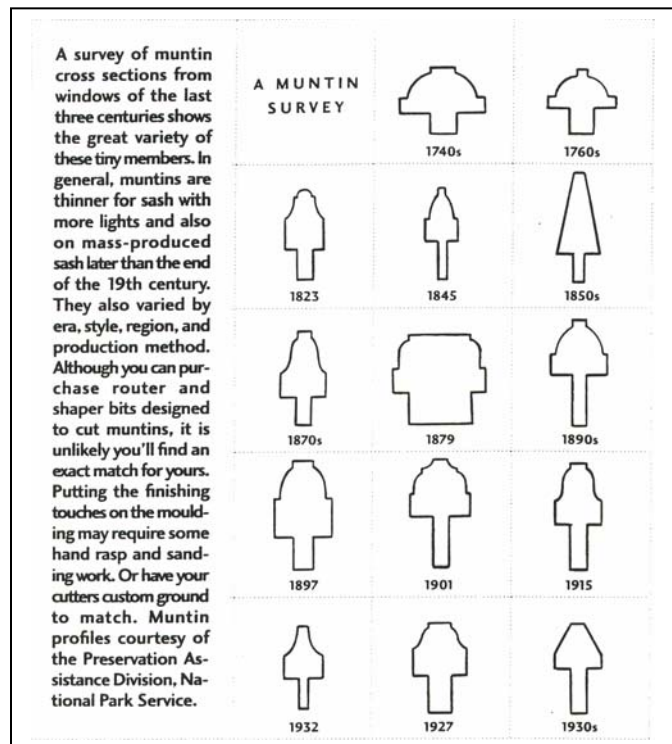

second half of the 19<sup>th</sup> century, large pieces of glass in large windows were a symbol of prosperity and status as was typical in the Victorian era. By the late 19<sup>th</sup> and early 20<sup>th</sup> century, large sheets of glass were readily available, as well as plate and even curved or bent glass. This led to more creativity with regard to window design. This neighborhood was built in the early

20<sup>th</sup> century with architectural styles that most typically used 6/6, 6/1 or 9/1 or other arts and crafts designs such as 3/1 or stained glass above a large single pane of glass.

The double hung window was a great departure from the earlier casement window which worked in a similar fashion as a door on hinges with a locking mechanism on the opposite side as the hinges. The double hung window works with a pulley system and the use of counterweights. Long heavy metal weights were attached to each side of the window “sash” by means of cotton cords, chains, or metal spring tapes such that the window “hung” or was suspended in a channel. The weight of the window was matched by the paired weights so that the window lifted and lowered easily. These weights travel in a linear cavity within the wall adjacent to the window. There is a small door hidden behind the sash and trim that allows access to this cavity and these weights. There are single hung windows which refer to a window where only the lower sash operates and the upper sash is fixed in place – this means there are only two pulleys and two weights as opposed to four of each. The benefit of double hung windows are that you can lower the upper sash and allow heat which rises out the top while lifting the lower sash and allowing cool air in the bottom.

These counterweighted sash are held in place in their respective channels with **wood stops** (interior trim) and **parting beads** at the jambs of the frame. Each window sash has two “**jamb stiles**” (vertical members) and a “**meeting rail**” (horizontal members). The lower sash has a “**sill rail**” and the upper sash has a “**head rail**.” The meeting rail is logically the rail where the two sash meet in the middle. This is often the location of sash locking hardware. The **muntins** hold the panes of glass in place.

On the interior face these muntins have a carved profile, while on the exterior there is a shallow rabbet or ledge on which the glass sits and is then covered with glazing putty which is beveled to the wood “tongue” of the muntin and eventually hardens in place. These are generally all the components that make up your wood double hung window. While each component can be damaged making the operation of the window difficult, each can equally be repaired and the window restored to easy operation.

## **1: Removing the Window sash**

*(Tools needed: utility knife, one or two small flat putty knives, screw driver, pencil)*

To start in removing the window sash you need to understand how the window parts work together. The pieces are essential parts of a kit that fit together in a logical order. Each sash, upper and lower, run in their own "track" separated by what is referred to as a parting bead. The lower sash is held in place against the parting bead with the jamb stop. This stop is usually a carved decorative interior trim piece. At first glance it looks as though the stop is one continuous piece on three sides of the window, but in fact it is 3 separate trim pieces mitered together at the corners. You need to remove at least one stop to

remove the sashes. To do this you should take a utility knife with a sharp blade and carefully cut the paint along the outer seam. Then take a thin putty knife to slip in behind the stop and rock the knife to lightly pry the stop free. The stop mostly likely is held in place with several finish nails, although there are some windows where the stops are attached with counter sunk screws. If this is the case simply clear the paint away and gently unscrew the stop screws being careful not to strip them, as they are typical brass screws which are soft and tend to strip with force. Using two putty knives you can rock the stop off without damaging the wood and without pulling the nails through. If you are removing more than one window make sure you ID the stop so you know to which window it returns.



© 2000-2004 JOHN C. LEEKE, Preservation Consultant 207 773-2306

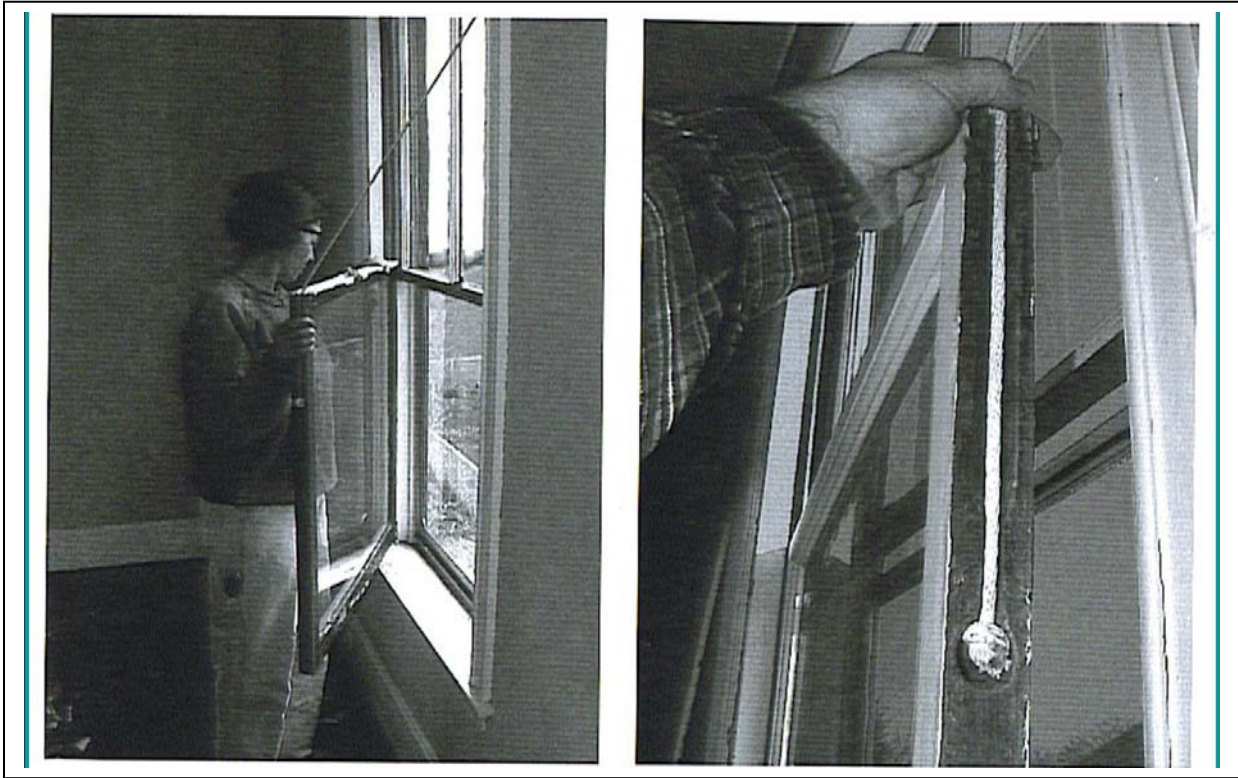

With the jamb stop off, the lower sash is loose and can tilt inward. The sash is simply hanging on two ropes on either side. If you swing out the side of the sash where the stop has been removed, you can disconnect the rope while securely holding the sash. This will then allow you to swing the other side free and disconnect this side cord. Make sure the knot at the end of the rope does not come unknotted or that it slips through the pulley. To do this you can create a larger slip-knot in the cord to keep the weight suspended in the pocket and keep the cord accessible on the outside.

#### **Windows that are Painted Shut**

These are the steps for replacing a broken cord, however what if the window sashes are painted shut? This is often the case when windows are painted with little care and regard to the window itself. In order to loosen the paint and get the window moving again, it is helpful to have a sharp razor blade utility knife or artist's knife, not to mention spare blades. Carefully cut the paint where the seams around the sash are, without damaging the wood itself. If you can remove the two side stops first this will allow you to wiggle the lower sash to break the paint bond at the sill and meeting rail. Removing the upper sash takes a bit more muscle. You will need to score the paint between the sash and the parting beads. It is much more common for upper sashes to get painted shut. If you can get the lower sash out, you can then wiggle the parting beads out. Be careful while handling the parting beads, as they tend to split easily. If they break, they can sometimes be glued back together or simply replaced. When replacing the parting bead try to use a wood species that is less likely to swell and contract from changes in humidity levels, since this will certainly effect the operation of your windows.

## 2: Repair broken cords

(Tools needed: new sash cord, screw driver, light twine & small weighted article such as a nail, screw or a fishing weight, etc. Gloves optional)

If there is a broken cord or two, the sash will come out freely without the need to disconnect any ropes. However, this requires that you access the weight pocket door, remove the weight and thread new sash cord through the pulley to attach to the weight. The weight pocket door is located behind the jamb stop and the sash. Once both are removed you will see a narrow opening (access door) cut into the jamb frame. This door may be held in place with 2 short screws. If you remove these screws, you will gain access into the narrow cavity that houses the weights. Your weights for both the upper and lower sash should be seen in this cavity; however, the one with the broken cord will be sitting on the floor of the cavity. You need to pull this weight through the door of the jamb. This can be dirty work, since the weights are dusty, and there are often broken pieces of the plaster in the cavity. When you pull the weight out you will see the remnants of the broken sash cord. Remove the broken cord, noting how the cord is knotted around the weight. You will need to thread new cord up over the pulley and down into the weight cavity. A problem often encountered here is that the cord does not drop straight into the cavity and may get hung up on plaster or lath or the other weight. Solutions for dealing with this include

attaching a small weight to the end of a continuous piece of light twine and feeding it over the pulley and down into the cavity. This weight needs to be small enough to fit over the pulley, but heavy enough to pull the twine down straight into the cavity. You can use a screw, nail, or fishing weight. Once the light twine is successful hung over the pulley and free at both ends, you can then tie the non-weight cavity end of the twine to the end of the new sash cord using a "figure eight" sailing knot and gently pull it over the pulley from within the weight cavity.



Do not cut the final length of the new cord until it is tied to the weight and the weight is back in the cavity. The length is determined by lifting the weight to the top and aligning the end with the knot hole in the sash when the sash is in the lower-most position. This assures that there is not too much slack in the rope and that the window is sufficiently suspended and counterweighted with the weight.



FIG. 2.153. Attachment of sash cord to sash weight.

This assures that there is not too much slack in the rope and that the window is sufficiently suspended and counterweighted with the weight.

### **3: Replace broken glass or glazing putty**

*(Tools needed: utility knife, small paint scraper, electric paint stripping device, insulating material to protect glass, small amount of linseed oil, glazing putty or compound, glazing points/clips, putty knife, mineral spirits for clean up)*

Often windows need repairing either because there is a broken pane of glass (or two), or that the elements have so severely deteriorated the glazing putty on the exterior which holds the glass in place. Once the sash are out of the frame you can place them on a horizontal work surface. The exterior surface should be addressed first. Often the first step is to strip the exterior paint if it is in poor condition, i.e. flaking, alligatored, or built-up and sloppy. Paint stripping will be discussed in the next section. Once the paint is stripped you will be able to better assess the condition of the glazing putty. Often deteriorated putty is cracked or pulling away from the window at the muntins, stiles or rails. If the putty has been in place for a long time, it is most likely rock hard and if it is stuck to the glass you need to be careful with how much force you use to remove it since this can cause the pane of glass to break. Care should be used to avoid breaking glass, particularly if you have original, wavy glass. For this reason the putty needs to be removed by hand, rather than using any type of power tool. A paint stripping device that uses heat like a heat gun or a heat plate can be effective in softening the putty, however the glass should be protected from the sudden temperature changes which can cause it to crack. Using gypsum board wrapped with aluminum foil can be laid over the glass to insulate it. Again the tool of choice here for removing the putty is a sharp utility knife with spare blades. A small paint scraper with a carbide blade will also work. Be careful not to put too much pressure downward onto the glass.



Once the putty is removed you should find small metal objects that hold the glass against the wood. These are glazing points – which come in all different shapes and sizes. They are pushed into the wood far enough not to be seen under the glazing putty, but projecting enough flat against the glass to keep it stable and in place. If you are removing and replacing the pane of glass, these points need to be removed. When the glazing and points are removed from the exterior side of the sash, the glass may still not simply pop out. This is because it was placed into a small bead of putty on the interior surface or seat of the muntin rabbet. This putty can be scored carefully with your utility knife until the glass comes free.

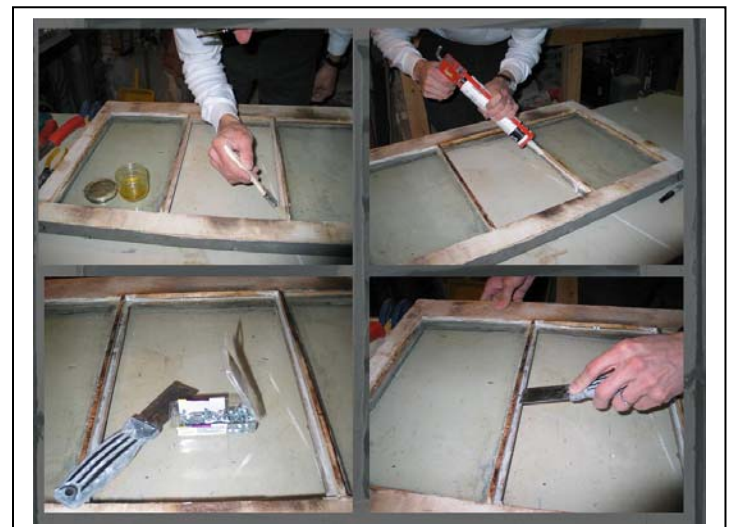

With the glass pane out, the remaining putty can be removed from the wood by scraping or sanding. Putty that remains stuck to the pane of glass can be removed by adding sufficient linseed oil to soften the hard putty.

Once the glass pane, whether reused or new, is cleaned up and the wood is stripped of excess paint and putty, you can make preparations for reinstalling the glass. The clean rabbets or shallow edge should be brushed lightly with a coating of boiled linseed oil or primed with an oil-based paint primer. By preparing the muntin in this way, it conditions the wood and prevents it from absorbing the moisture out of the new glazing putty causing it become brittle. Once the linseed oil has been applied a new thin bead of glazing putty should be applied on the rabbet. This does not need to be a lot of putty, just enough to cushion and seal the glass. With the pane of glass gently pushed into place, reinstall the metal glazing points using a number of them sufficient for the size of the



glass (generally one every 8-10 inches). A trick for easing the point into the wood, is to precut with the point of your utility knife. Use the flat end of your putty knife to push the points into the wood, using extreme care not to apply pressure downward, which will break the glass. Then the final glazing putty can be applied around the edge. It is helpful to take small amounts of putty out of the can, roll it in the palm of your hand like dough and create a long strand. Push and smooth it into place smoothing the seams. Once in place you can take a clean putty knife and drag it along the putty to create a beveled profile. This will pull excess putty away. Adding a tiny bit of linseed oil to your putty knife edge will prevent it from pulling the putty up. This may take several attempts to get the smooth bevel with the angle you desire. This is okay, as the putty can be reworked over and over again until you are happy with the results. Something to keep in mind when creating your bevel, is that the putty should not project out further than the rabbet's depth, otherwise you will be able to see the putty from the interior.

The putty should be allowed sufficient time to “cure” – curing or drying times should be listed on the packaging and can range from 24 hours to a week. During this time, be careful not to touch, gouge or smear the putty. The putty should not be painted until it has fully cured. This exterior paint when applied should cover the full beveled glazing putty and lap over onto the glass slightly to complete the weathertight seal.



### **Cutting Your own Glass**

You can cut your own glass with a glass cutter purchased at any hardware store for less than \$2.00. This requires a smooth clean surface, a straight edge, duct or masking tape, a glass cutting tool and your pane measurements. Measure your glass opening at the insides of the rabbet leaving enough space (1/8" max at each edge) for the glass to be easily inserted. Lay the sheet of glass on a smooth, clean, flat work surface. Mark dimensions on the glass with a wax pencil or marker, and lay a piece of tape on the inside edge of the line (on the glass you will use) and right off the pane of glass. Align a straight edge over the edge of the tape, and steadily roll the glass cutting tool along the cutting line from edge to edge, scoring the glass. You should have pushed down with enough force to cause a line to be etched into the glass surface. It is recommended to not score the glass twice, if you can help it. Move the sheet of glass to a sharp corner of the work surface aligning the cutting line with the surface corner. Gently push the scrap side of the glass sheet downward. The glass should break straight along the scored line. Proceed with cutting the other edge with the same steps.

Window glass can readily be purchased to your specified dimensions at almost any hardware store. Generally a 24"x36" pane of glass costs about \$12.00 or less. Make sure that they wrap it in heavy brown paper for safe transport. Some hardware stores will even reglaze a sash for you if you bring it to their store.

### **4: How best to strip paint**

*(Tools needed: chemical, mechanical or heat paint stripping tool, scraper with carbide blades, respirator/masks, abundant fresh air)*

Most every do-it-yourselfer has experimented with the various methods of stripping paint. There are a variety of methods that include chemical stripping with such products as 5F5, Peel Away, Citristrip, or other Methylene Chloride solutions. These strippers have varying degree of effectiveness depending on temperature and humidity levels, number of paint layers, and whether the paint is oil-based or latex. Using these strippers requires rubber gloves, plastic drop cloths, good ventilation, and mineral spirits for neutralizing the chemicals. In essence, the chemical softens the paint and turns it to "sludge" which can be scraped or wiped away. It is important to contain this liquefied paint and chemical and dispose of it properly. If allowed to come in contact with other surfaces it can damage those finishes.

Other methods for stripping paint are mechanical sanding or heating tools. Mechanical sanders can remove paint layers by abrading the paint off of the surface. You must start with a rough or coarse sandpaper at first and gradually decrease the coarseness. You typically need to change the paper frequently due to paint build-up in between the sand grains. Generally this method takes



away the top surface of the wood substrate as well as the paint, and should not be overly used due to the likelihood of losing original details or profiles. Heating tools can include heat guns (hot air), a heat plate or an infrared stripper. Each works with the same principle of heating up the layers of paint making them easier to scrape away. A heat gun looks like a hair dryer and directs up to 1,100°F of heat at a specific location, while a heat plate or infrared stripper heats up the painted surface directly beneath its heating element. A heat plate looks like an electric stove burner with a metal shield and a handle. It is held against a painted surface for a few seconds until the paint lifts and bubbles. **The heat generated is less than that with a heat gun but sufficient to scorch a surface if care is not taken.** In all cases the type of scraper used will impact the effectiveness of the paint stripping. It is highly recommended that a scraping tool with a replaceable carbide blade be used. These blades stay sharper longer and are effective even when just used to dry scrape. These scrapers tend to cost more than the average “Red Devil” scraper or putty knife (\$24 vs. \$4) but are well worth the investment. Replacement blades tend to run about \$5 for a package. These should not be needed for a while.

As with any home improvement project, safety is important. Please take care to protect your home and materials, and YOURSELF from hazardous materials or the hazards of fire. When using chemicals or heat that may result in hazardous vapor, you should protect yourself with a respirator or mask. Increasing the amount of fresh air with sufficient ventilation is important as well. All hazardous materials should be disposed of properly.

### **5: Repainting & What tools to use**

Once the built up or deteriorated paint has been removed it is important to recondition and repaint the bare wood before it can deteriorate due to exposure to water, sun, and other erosion. All exterior wood should be primed first before painted with a finish coat of paint. A primer seals the wood, evens out the grain and provides a better bond with the finish paint. While it is tempting to use a latex primer given their availability, their easy clean up and fast drying time, it is **STRONGLY** recommended that an oil-based, or alkyd primer be used in all exterior situations. There are many reasons for this, but the most important is that oil based paints condition the wood when applied to a bare surface. The oils or resins in alkyd paint penetrates deeper into the wood and allow the wood to repel moisture, preventing rot and insect infestation and dries with a harder more durable surface. A latex or acrylic paint in contrast simply adheres to the top surface of the bare wood and seals it with a rubber or plastic-like covering. Because it does not absorb into the grain of the wood and doesn't condition the wood, it is more likely for rot to occur under the paint surface if there is any break in the paint seal and water is allowed to infiltrate the wood. The ultimate result is major paint failure as the water within the wood tries to escape and evaporate but is trapped by this paint layer. Water will then force its way out taking the paint coating with it. This defeats the whole purpose of carefully stripping and restoring your wood windows or surfaces. Windows that are prepared and painted correctly should last as long as modern replacements if not longer.



Generally all windows and doors should be painted with an oil-based, or alkyd finish paint as well as oil based primer because these paints give a harder more durable finish for window and door surfaces which see a lot of wear and tear.

When painting windows, a “sash” brush is the easiest to use for getting those tough to paint muntins. A sash brush has an angled tip and is generally small in width (1-3”). Only natural china bristle brushes should be used for oil or alkyd paints. While oil paints and china bristle brushes tend to be pricier than latex paints and synthetic brushes, you will get what you pay for – a long lasting paint surface and a quality brush that should last for years of painting projects. The key to keeping a good brush in service for years is prompt and thorough cleaning with mineral spirits. Make sure to rinse in mineral spirits until no paint drains out of the brush when dragged against the side of your rinsing container. Oiling the bristles at the binding can also prolong the life and service of your quality brushes.

## 6: How to add weatherstripping

Weatherstripping is the easiest way to keep your old wood windows efficient and draft-proof. Although modern window manufacturers will have you believe otherwise, double-glazed window units are not necessarily better than single-glazed windows in terms of energy efficiency. Studies have shown that a double-glazed window may save \$3.00 a year per window (at 10 cent per KWH) in energy cost, yet this energy savings takes 50-70 years to recover when the cost of installation is factored in. The real enemy in energy efficiency is air infiltration not the insulating factor. In fact, aluminum and vinyl replacement windows have a lower insulating factor than the old wood windows they replace since wood is a much better insulator than vinyl (plastic) or aluminum. So the solution for better energy efficiency is stopping the air infiltration through the installation of effective weatherstripping.

There are generally four locations where air is most likely to get through your window:

- 1) At the jambs
- 2) At the sill
- 3) At the head
- 4) At the meeting rails

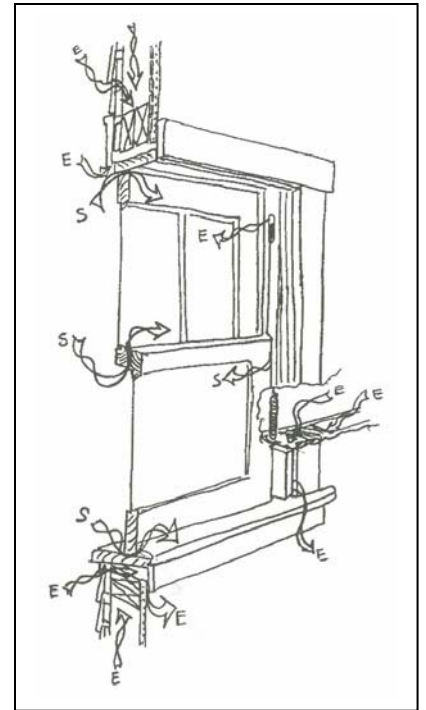

For the jambs, we recommended a spring bronze strip which is nailed to the jamb channel along the interior side at the stop or parting bead. The window sash slides against this bronze strip which is bent slightly to add pressure against sash and creating a "V"-shape to catch the air. The degree to which this bronze strip is bent can also adjust the amount of movement in your sash and can keep it from rattling in its channel.

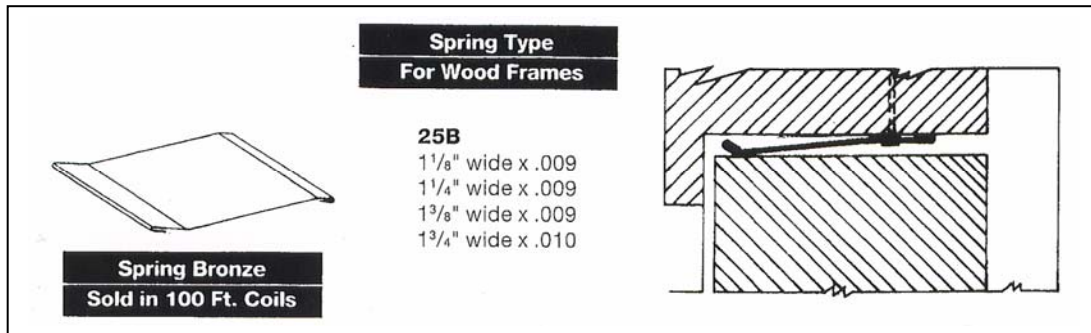

At the sill and head both, a bronze strip can also be used. However, a more effective method of keeping the air out is to add an extruded silicon open bulb with a barbed leaf. In simpler terms this is a rubber gasket which is hollow and has a "tail" which is shoved into a groove in the window edge. This gasket forms to any uneven-ness of the wood sill or header so that air cannot get past it.

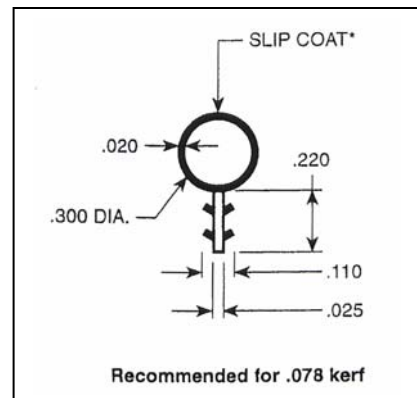

At the meeting rails it is advisable to install some type of interlocking metal strip. There are “U”-shaped strips that are attached to the inside of one sash, and a matching flange strip that is attached the outside of the other sash. When the window is closed and the sashes are in their closed positions, these metal strips interlock closing off any air gap.

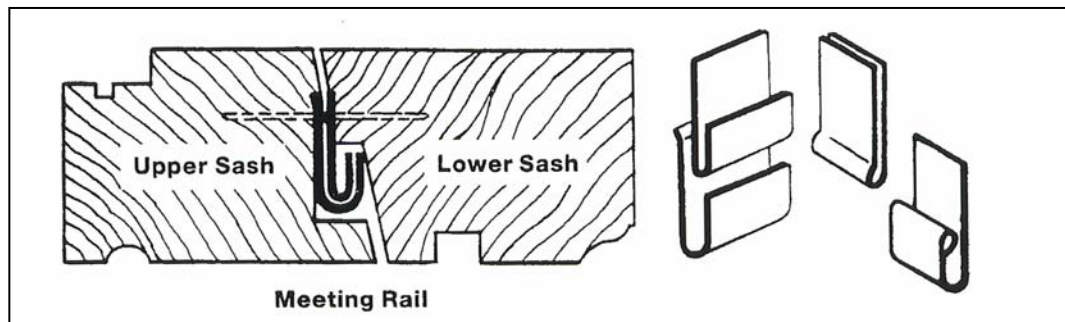

Storm windows are another option for increasing the energy efficiency of your windows. The key to insulation through the use of storm windows is that the greater the air space between the interior window and the exterior storm, the greater the insulation value – provided the storm window is air tight. Unfortunately most aluminum triple-track storm windows are not air-tight and thus are significantly inferior to single piece wooden storm windows. If these wood storms make use of weatherstripping the energy efficiency is even more improved.



---

For additional step-by-step instructions for addressing all your window needs, Old-House Journal is a wonderful resource both online and in their old issues. See also, the National Park Service's Preservation Brief #9 on the Repair of Historic Wood Windows by John H. Myers. <http://www.cr.nps.gov/hps/tps/briefs/brief09.htm>

*If you have any technical questions regarding your old wood windows, please feel free to contact Kim Konrad Alvarez at Landmark Consulting – [kkalvarez@landmarkconsulting.net](mailto:kkalvarez@landmarkconsulting.net) or 518-458-8942. While not official window “specialists,” Kim and her husband, Jack, have restored more than 50 windows in varying degrees of deterioration over the years and have learned the tricks of the trade through their hands-on experience and research. Kim is a historic preservation consultant and Jack is a registered architect with a specialty in historic buildings.*