

CARLSBAD FLANGE MR16 WELL LIGHT



DESCRIPTION

The Carlsbad Flange Well Light is ideal for recessed and hardscape applications like being core drilled into concrete, pavers, and driveways. (The recommended core drill size is 2.75 inches.) The Carlsbad Flange is fitted for any MR16 lamp and comes to life with the Brilliance Chameleon MR16. Like the original Carlsbad fixture, the flat glass top comes in a brass finish.

CARLSBAD FLANGE WELL LIGHT

Use	Well Lighting & Underground Up Lighting in Recessed & Hardscape Applications	
Finish	Brass	
Includes	PVC Sleeve, LightingShrink Professional Crimp and Heat Shrink Cable Connector	
Order With Lamp	MR16, 4W, 2700K, 30°	CARLSBAD-UG-MR16-BR-FLANGE
Order Without Lamp	Fits Chameleon MR16, MR16	CARLSBAD-UG-MR16-BR-FLANGE-NL

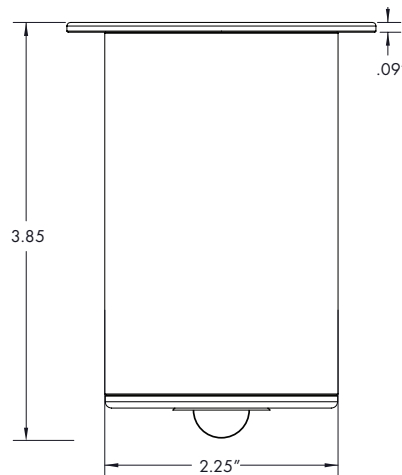

Brass (BR)



CARLSBAD-UG-MR16-BR-FLANGE

INSTALLING THE LAMP

1. Remove the rear cap and pull out the spring.
2. Set the MR16 lamp on top of the spring and plug it into the socket.
3. Insert this assembly into the fixture body with the front of the lamp toward the lens.
4. Screw the back cap onto the fixture body and hand tighten.

INSTALLING THE FIXTURE: GROUND MOUNT WITH SLEEVE

1. Dig a hole in the ground approximately 6" wide by 10" deep.
2. Connect the power cable to the fixture, leaving 2' landscape cable coiled in the bottom of the fixture for future service.
3. Pour 8" pea gravel in the hole.
4. Place the fixture in the center of the hole.
5. Add more pea gravel to fill the hole 1" before the fixture lip. This allows for proper drainage around the fixture.
6. Apply glass wax on top of the lens to protect against standing water.

INSTALLING THE FIXTURE: CORE DRILLING WITH SLEEVE

1. Core drill a hole 2 3/4" wide by 10" deep into concrete or hardscape. Be sure there is room in the core drilled hole for proper drainage.
2. Attach the fixture cable to the main cable with the Lighting Shrink cable connection provided.
3. Insert the fixture into the sleeve and drop the fixture and sleeve into the core drilled hole.
4. Apply glass wax on top of the lens to protect against standing water.