

# MINI BEAM STAKE & SHIELD



## DESCRIPTION

The Mini Beam is the perfect lamp to bring light to hard-to-reach places, whether under water, in a water feature, under stairs, stone walls, stone lanterns, or any small space. This directional product solves the issue of fitting a fixture and a lamp into a small area. Enhanced ESD (Electro-Static Discharge) protection (IEC-61000-4-2). We recommend using LightingShrink connections for Mini Beams. Dimmable with Brilliance Dimmer and most magnetic transformers.

## MINI BEAM

Use	<b>Fully Submersible in Water Features or Heavy Irrigation Areas Small Spaces that Need Directional Light</b>
Finish	<b>Brass</b>
Includes	<b>12 ft Lead</b>
Integrated Lamp	<b>Mini Beam - 1.5W, 90 Lumens, 36°, CRI 90, IP68, 8-15VAC, 3 year warranty, 2.50VA 30,000 hrs</b>
	<b>2700K</b> MINI-BEAM-2700-90
	<b>3000K</b> MINI-BEAM-3000-90
	<b>Amber</b> MINI-BEAM-AMBER-90
	<b>Blue</b> MINI-BEAM-BLUE-90
	<b>Green</b> MINI-BEAM-GREEN-90
	<b>Mini Beam - 3W, 200 Lumens, 36°, CRI 90, IP68, 8-15VAC, 3 year warranty, 3.75VA, 30,000 hrs</b>
	<b>2700K</b> MINI-BEAM-2700-200
	<b>3000K</b> MINI-BEAM-3000-200
	<b>Mini Beam - 6W, 400 Lumens, 36°, CRI 90, IP68, 8-15VAC, 3 year warranty, 9.23VA, 30,000 hrs</b>
	<b>2700K</b> MINI-BEAM-2700-400
	<b>3000K</b> MINI-BEAM-3000-400

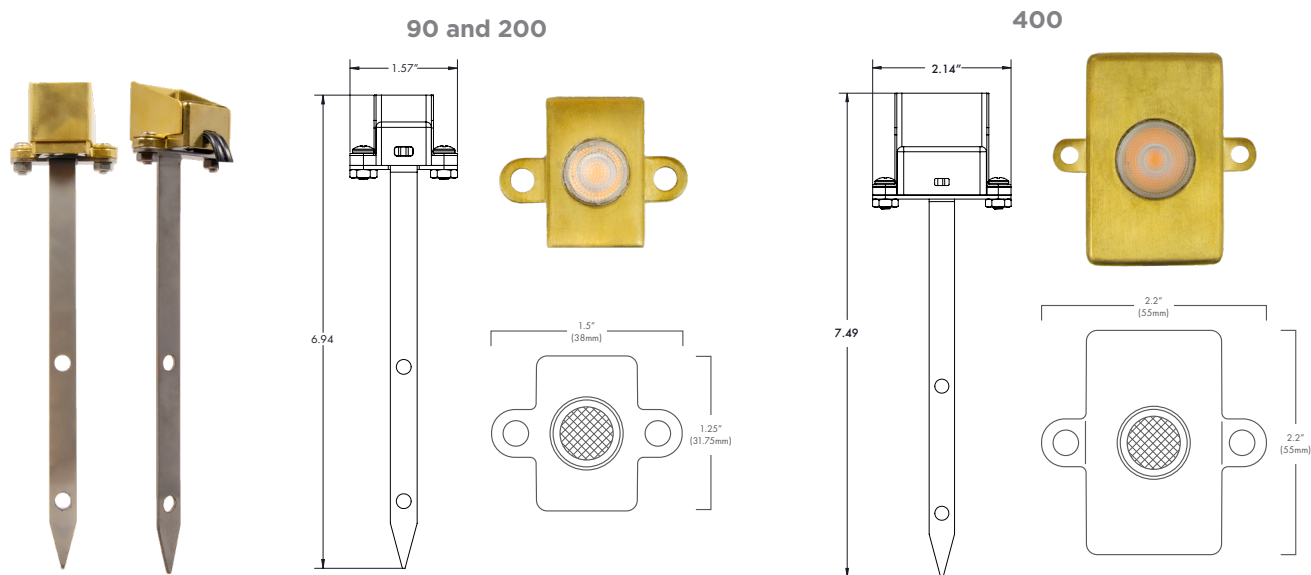

\*Note: Corrosive chemicals in the water of ponds and fountains as well as natural hard water and salt water could affect the appearance of the coating, but will not impact functionality of the product. For this reason, Brilliance LED makes no warranty or guarantee for change in appearance when this product is used in water, as it is designed to be used. (NOT for use in swimming pools, spas, or any contained water basin in contact with people per NEC Article 682.)

# GUTTER MOUNT Mini Beam Accessory



## DESCRIPTION

The Gutter Mount is an easy-to-affix, sleek accessory bracket that pairs with Mini Beams to light upper segments of structures. The low profile of the Gutter Mount makes it an unobtrusive lighting option compared to traditional uplight fixtures.

The stainless steel bracket is engineered to work with the various sizes of Mini Beams and offers 30 degrees of vertical adjustment. It can also be painted to match its surroundings. Includes two bracket mounting screws and zip ties. Mini Beam sold separately.

## GUTTER MOUNT

Use	<b>Upper Segments of Residential or Commercial Structures, Like Dormers or Other Architectural Features</b>	
Finish	<b>Stainless Steel</b>	
Includes	<b>Gutter Mount, Mounting Bracket Screws, Zip Ties</b>	
Warranty	<b>Lifetime</b>	
Order Without Light Source	<b>Fits Any Mini Beam</b>	GUTTER-MOUNT



Gutter Mount shown with 400 Lumen Mini Beam (not included)

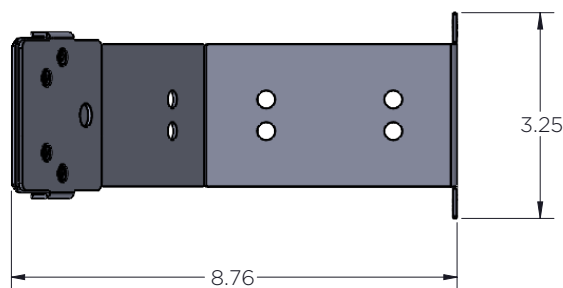

## INSTALLING THE GUTTER MOUNT

1. Attach the Mini Beam to the Gutter Mount using the supplied bracket screws.
2. Attach the Gutter Mount to the fascia of the structure.
3. Adjust the gimbal bracket to the preferred location and tighten the screws.
4. Secure the Mini Beam wire to the Gutter Mount bracket using the supplied zip ties.
5. Wire the Mini Beam into a low voltage power supply.