

# VERSA BEAM Modular Integrated Fixture



## DESCRIPTION

The Brilliance Versa Beam is designed to be an easy-to-install, versatile light source. The Versa Beam can be used to achieve nearly any lighting configuration in landscape lighting designs. Because of its modular design, the VersaBeam can be used in hanging applications, hardscape applications, in ground applications, and overall landscape lighting. It provides indirect light for interest, as well as safety. It is dimmable with the Brilliance Dimmer and most magnetic transformers.

All configuration options use the same light engine with 3W, 180 lumen output, 8-15 VAC, and 90 CRI. The brass light engine housing ensures the Versa Beam dissipates heat efficiently while withstanding harsh elements and is rated IP 65. Best of all, the Versa Beam comes fully assembled with finish and configuration option of your choice already attached, so it is ready to use out of the box.

If used as a directional light, the 30 degree optic is pre-installed. If you prefer the 15, or 60 degrees, choose optic of your choice from the interchangeable options, or remove the optic for a wider beam angle. Then, simply install the fixture in one of its many applications. In hardscape and masonry applications, the Versa Beam is designed to be recessed into standard 1" electrical conduit, making rough-ins simple, without the need for complicated back boxes or pour sleeves.

## VERSABEAM

Use	<b>Areas with Elevation Changes, Hardscape, Hanging or Overall Landscape Lighting</b>
Finish	<b>Brass, Brass + Black Baked Enamel (BE) , Brass + Nickel Baked Enamel (BE)</b>
Warranty	<b>5 years</b>
Includes	<b>Versa Beam Light Engine, 12ft. Lead</b>
Integrated Light Engine	<b>3W, 2700K, 180 Lumens, CRI 90+, IP65, 8-15VAC, 4.78VA, 5 year warranty</b> <b>3W, 3000K, 180 Lumens, CRI 90+, IP65, 8-15VAC, 4.78VA, 5 year warranty</b>

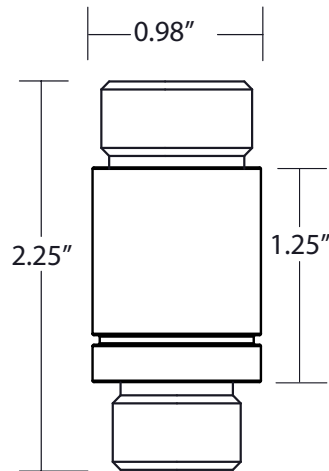

Light Engine



Brass (BR)

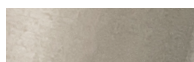

Nickel (NI)



Brass + Black (BK)

# VERSA BEAM SOIL APPLICATIONS



## VERSABEAM OPTICS INSTRUCTIONS

1. Remove the accessory cap on the top of the unit.
2. Choose the Optic lens for your application (lenses available in 15°, 30°, and 60° beam angles).
3. Place the Optic over the diode. For a wider beam angle, do not use an Optic.
4. Place the Optic Louver Retention Ring over the Optic.
5. Set the Honeycomb Louver on the Optic Louver Retention Ring, if applicable.
6. Thread the corresponding accessory cap over the Optic and Hex Louver.

## SOFT SOIL APPLICATIONS: INSTALLING THE GROUND STAKE & FIXTURE

1. Connect the power cable from the light engine to the landscape cable.
2. Lay the power cable into the slotted relief on the stake.
3. Press the light engine and stake into the ground.
4. Use a level to ensure the top of the stake is level with the ground.
5. Use a good solid, mechanical cable connection to make all cable connections.
6. For all cable connections, follow the manufacturer’s guidelines and installation procedures.

## HARD SOIL APPLICATIONS: INSTALLING THE GROUND STAKE & FIXTURE

1. Dig a hole approximately 4” wide by 10” deep and gently tap the stake into the ground with a rubber mallet.
2. Use a level to ensure the top of the stake is level with the ground.
3. Install the light engine onto the stake and lay the power cable into the slotted relief on the stake.
4. Connect the power cable from the light engine to the landscape cable.
5. Press the light engine and stake into the hole.
6. Use a good solid, mechanical cable connection to make all cable connections.
7. For all cable connections, follow the manufacturer’s guidelines and installation procedures.

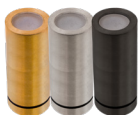

### VB-01 | Cap

*Includes Cap, Light Engine, Optics (15°, 30°, 60°), & Honeycomb Louver*

	2700K	3000K
<b>Brass</b>	VB-01-BR-2700	VB-01-BR-3000
<b>Brass + Black (BE)</b>	VB-01-BK-2700	VB-01-BK-3000
<b>Brass + Nickel (BE)</b>	VB-01-NI-2700	VB-01-NI-3000



### VB-11 | Knuckle, Shield, Cap

*Includes Knuckle, Shield, Cap, Light Engine, Optics (15°, 30°, 60°), & Honeycomb Louver*

	2700K	3000K
<b>Brass</b>	VB-10-BR-2700	VB-10-BR-3000
<b>Brass + Black (BE)</b>	VB-10-BK-2700	VB-10-BK-3000
<b>Brass + Nickel (BE)</b>	VB-10-NI-2700	VB-10-NI-3000



### ABS MOUNTING STAKE

*Sold Separately*

<b>Black</b>	STAKE
--------------	-------

# VERSA BEAM HANGING APPLICATIONS



## DOWN LIGHT/HANGING APPLICATIONS: INSTALLING WITH THE HANGING LOOP

1. Thread the corresponding fixture cap over the Optic and Hex Louver.
2. Thread the Hanging Loop onto the cable end of the VersaBeam.
3. Leave drip loop on the cable for this application.
4. Use a good solid, mechanical cable connection to make all cable connections.
5. For all cable connections, follow the manufacturer's guidelines and installation procedures.



### VB-04 | 6" Acrylic Bubble Rod

Includes 6" Acrylic Bubble Rod, Light Engine, Hanging Loop

	2700K	3000K
<b>Brass</b>	VB-04-BR-2700	VB-04-BR-3000
<b>Brass + Black (BE)</b>	VB-04-BK-2700	VB-04-BK-3000
<b>Brass + Nickel (BE)</b>	VB-04-NI-2700	VB-04-NI-3000



### VB-06 | Perforated Shield

Includes Perforated Shield, Light Engine, Hanging Loop

	2700K	3000K
<b>Brass</b>	VB-06-BR-2700	VB-06-BR-3000
<b>Brass + Black (BE)</b>	VB-06-BK-2700	VB-06-BK-3000
<b>Brass + Nickel (BE)</b>	VB-06-NI-2700	VB-06-NI-3000



### VB-05 | 12" Acrylic Bubble Rod

Includes 12" Acrylic Bubble Rod, Light Engine, Hanging Loop

	2700K	3000K
<b>Brass</b>	VB-05-BR-2700	VB-05-BR-3000
<b>Brass + Black (BE)</b>	VB-05-BK-2700	VB-05-BK-3000
<b>Brass + Nickel (BE)</b>	VB-05-NI-2700	VB-05-NI-3000

# VERSA BEAM FLANGE APPLICATIONS



## VERSABEAM OPTICS INSTRUCTIONS

1. Remove the accessory cap on the top of the unit.
2. Choose the Optic lens for your application (lenses available in 15°, 30°, and 60° beam angles).
3. Place the Optic over the diode. For a wider beam angle, do not use an Optic.
4. Place the Optic Louver Retention Ring over the Optic.
5. Set the Honeycomb Louver on the Optic Louver Retention Ring, if applicable.
6. Thread the corresponding accessory cap over the Optic and Hex Louver.

## CONCRETE APPLICATIONS: INSTALLING WITH THE FLANGE ACCESSORY

Use this method in both Horizontal and Vertical applications.

1. Use 1" PVC conduit as a sleeve.
2. Cut the 1-inch PVC conduit to length.
3. Drop the VersaBeam light engine with the flange cap into the PVC sleeve.
4. Place a small amount of silicone on the underside of the flange cap.

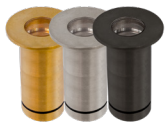

### VB-02 | Round Flange

Includes Round Flange, Light Engine, Optics (15°, 30°, 60°), & Honeycomb Louver

	2700K	3000K
Brass	VB-02-BR-2700	VB-02-BR-3000
Brass + Black (BE)	VB-02-BK-2700	VB-02-BK-3000
Brass + Nickel (BE)	VB-02-NI-2700	VB-02-NI-3000



### VB-03 | Square Flange

Includes Square Flange, Light Engine, Optics (15°, 30°, 60°), & Honeycomb Louver

	2700K	3000K
Brass	VB-03-BR-2700	VB-03-BR-3000
Brass + Black (BE)	VB-03-BK-2700	VB-03-BK-3000
Brass + Nickel (BE)	VB-03-NI-2700	VB-03-NI-3000



### VB-07 | Round 4 Window

Includes Round 4 Window, Light Engine

	2700K	3000K
Brass	VB-07-BR-2700	VB-07-BR-3000
Brass + Black (BE)	VB-07-BK-2700	VB-07-BK-3000
Brass + Nickel (BE)	VB-07-NI-2700	VB-07-NI-3000



### VB-08 | Square 4 Window

Includes Square 4 Window, Light Engine

	2700K	3000K
Brass	VB-08-BR-2700	VB-08-BR-3000
Brass + Black (BE)	VB-08-BK-2700	VB-08-BK-3000
Brass + Nickel (BE)	VB-08-NI-2700	VB-08-NI-3000



### VB-09 | Round Eyebrow

Includes Round Eyebrow, Light Engine

	2700K	3000K
Brass	VB-09-BR-2700	VB-09-BR-3000
Brass + Black (BE)	VB-09-BK-2700	VB-09-BK-3000
Brass + Nickel (BE)	VB-09-NI-2700	VB-09-NI-3000



### VB-10 | Square Eyebrow

Includes Square Eyebrow, Light Engine

	2700K	3000K
Brass	VB-10-BR-2700	VB-10-BR-3000
Brass + Black (BE)	VB-10-BK-2700	VB-10-BK-3000
Brass + Nickel (BE)	VB-10-NI-2700	VB-10-NI-3000