

manthey kula

Pilestredet 75C
0354 Oslo

www.mantheykula.no
email: maku@maku.no

Beate Hølmebakk: +47 4528 9292
Per Tamsen: +47 9326 0264

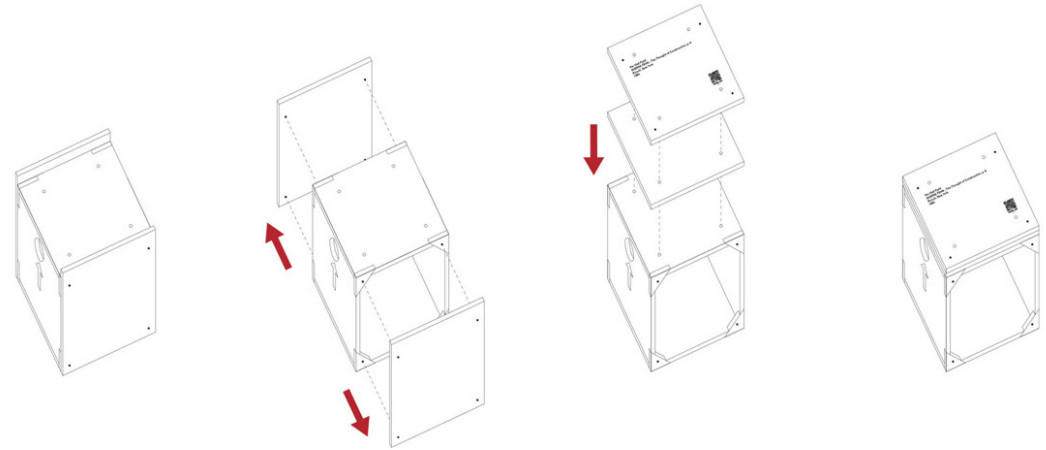

MK521

Location: The Nordic Pavilion, Venice
Built installation: 2012
Client: The National Museum - Architecture
Cost: NKr 20 000

MK521 is a sound installation for Venice Biennale 2012 that celebrates the 50th anniversary of the Nordic pavilion.

The project has two sources: The fictional dialogue between Sverre Fehn and Andrea Palladio written by Fehn in 1964. The other is the module of 521 millimeters that Fehn made use of in the design of the Nordic Pavilion.

The installation is hung from an opening in the roof truss of the pavilion that used to give space to a now dead tree penetrating the structure. The recorded dialog is played from a suspended speaker placed in a tailored trunk made of natural wool felt. During transport the piece is contained within a crate of fiberboard. After installation the crate becomes seating for the listener. The crate measures 521x521x521 millimeters and is as such designed specifically for the given site in the pavilion.



Photo credit: Manthey Kula