

TABLE OF CONTENTS

Standard Components	1
Guidelines for Location and Suspension Height AFF.....	2
Suspension Detail - Apex Rail Profile	3
Suspension Detail - Rubber Seals and Vacuum Holster™	4
Suspension Detail - Accessories; Troubleshooting Guide	5
Dimensions and Weights; Inclusions/Exclusions.....	6



I-ARHC-02

Standard Components of the High Capacity Apex Rail

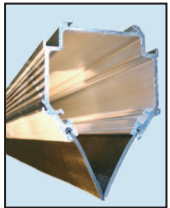

I-ARSC-01

Apex Rail Profile, Part # AR-R201

- High Capacity: With rubber seals installed, a cross sectional area of 57 square inches is created
- Robust: Wall thickness is 3/16" or greater
- Standard lengths of 12'
- Shipped without rubber seals installed
- Weight: 9.0 lbs/ft

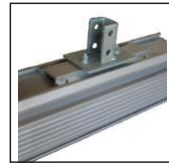

I-ARSC-05

Suspension Bracket, Part # AR-R107

- Adapts to 1 5/8" UniStrut
- Slides along the top of the Apex Rail
- Tighten 4 Allen screws to fix position
- Suspension point required 3' or less from each end of rail run, and at least every 15' between
- Weight: 5 lbs each

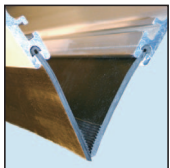

I-ARSC-01

Rubber Seals, Part # AR-R102

- Creates an airtight seal when exhaust fan is activated, but permits trolley to be moved
- Standard lengths of 100' - rubber patches and cement are provided for longer lengths
- Grooves face inward
- Weight: .5 lbs/ft

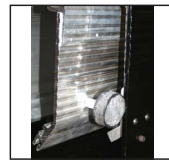

I-ARHC-01

End Safety Stop, Part # AR-R108

- 1 set of 2 stops for each end of rail
- Installer to drill 3/8" hole at 4" from end of rail
- Hardware provided to secure to exhaust rail
- Weight: .5 lbs per set (of 2)

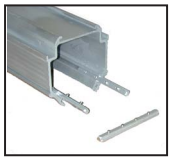

I-ARSC-02

Internal Rail Coupling, Part # AR-R103

- 2 per rail junction
- Insert coupling into pocket on interior of rail, with 2 Allen screws on each rail, and tighten
- Weight: .25 lbs each



I-ARSC-07

Holster Tug Strap, Part # AR-R109

- 1 per Vacuum Holster™
- To be installed toward the service bays, not the drive
- 3/8" hole is pre-drilled in Hose Holster; installer to use provided hardware to mount tug strap
- Weight: 1 lb each



I-ARSC-05

External Rail Coupling, Part # AR-R104

- 1 per rail junction
- Insert coupling into pocket on top of rail, with 2 Allen screws on each rail, and tighten 4 screws
- Weight: 1 lb each



I-VHT6-01

Sliding Trolley, Part # AR-H101-(6/8)

- Provided with two flexible straps to attach to Holster
- Straps have multiple pre-drilled holes; select holes so that bottom rim of tailpipe adapter is 6'3" AFF
- Weight, 6" trolley only: 38 lbs
- Weight, 8" trolley only: 45 lbs



I-ARSC-04

Rail End Cap, Part # AR-R113

- 2 sets per Apex Rail
- After installing rubber seals, trolleys and safety stops, fasten to Apex Rail with included hardware
- Weight: .50 lbs each

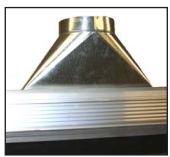

I-ARSC-06

Duct Transition Piece Part # AR-R106-(08/12)

- Enables duct connection anywhere on the Apex Rail
- 8" or 12" diameter to duct, depending on CFM
- Installer must cut rectangular hole on top of the Rail
- Weight: 2 lbs each

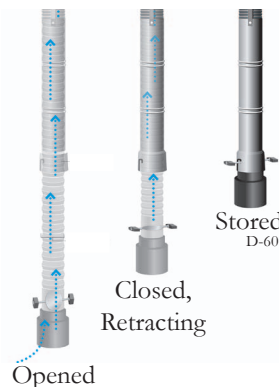

Vacuum Holster™ Part #: Various

- Attaches to sliding trolley by two flexible straps
- Includes tailpipe adapter with attachment clamp, rotational damper assembly, Hose Holster storage cylinder, and silicon-Kevlar exhaust hose rated for 600 F continuous, 700 F intermittent
- Closing of rotational damper causes the exhaust hose to compress, assisting in the storage of exhaust hose into the Hose Holster storage cylinder

GUIDELINES FOR LOCATION OF HIGH CAPACITY APEX RAIL, SIDE VIEW

In High Capacity applications, the location of the Apex Rail can vary, depending upon 1) the layout of the bays and 2) the type of vehicles being serviced. Three common scenarios are illustrated below.

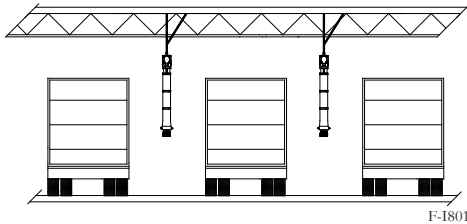

F-1801

DIAGRAM #1: DRIVE THROUGH BAYS

The bays are drive through, and the vehicles can be parked at any location along the length of the service bay. The Apex Rail should simply be located between the drive through bays.

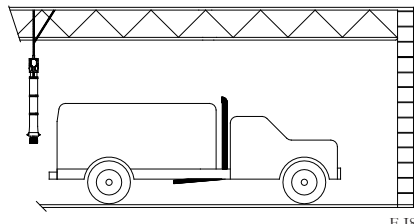

F-1802

DIAGRAM #2 PULL-IN, BACK-OUT BAYS WITH STANDARD LENGTHS

The service bays are defined, pull-in back-out bays. If the fleet has a standardized size, and if the length from the back of the cab to the rear bumper does not exceed 15', place the Apex Rail 1-2' behind the rear bumper when the vehicle is in the parked position.

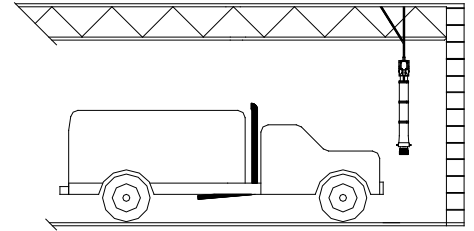

F-1803

DIAGRAM #3 PULL-IN, BACK-OUT BAYS WITH VARIABLE LENGTHS

Here, the service bays are defined, pull-in back-out bays, and the length of the vehicle varies widely. In this circumstance, it is recommended to place the Apex Rail 1-2' in front of the bumper of the parked vehicle.

GUIDELINES FOR SUSPENSION HEIGHT OF HIGH CAPACITY APEX RAIL

For 6" or 8" Vacuum Holsters™, the bottom of the aluminum profile should ideally be 14'6" AFF, and the bottom rim of the tailpipe adapter should be 6'3" AFF, +/- 3".

straps. These are shipped in 3' lengths, with holes pre-punched every 6". The diagrams below show scenarios for three different rail mounting heights. (See page 4 for more information).

The Vacuum Holster™ is attached to the trolley by two flexible

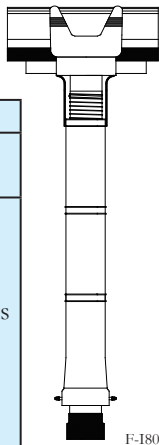

F-1804

DIAGRAM #1
APEX RAIL IS 14'6" - 17'6" AFF.
If the bottom of Apex Rail is 14'6"-17'6" AFF, select the pair of pre-punched holes that results in bottom rim of tailpipe adapter being 6'3" AFF. Trim excess from the strap.

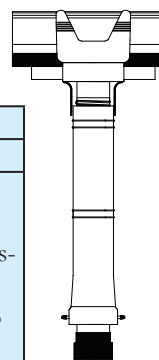

F-1805

DIAGRAM #2
RAIL IS < 14'6" AFF.
If bottom of the Apex Rail is less than 14'6" AFF, use the shortest possible strap and field-cut the Hose Holster, but no more than 22".

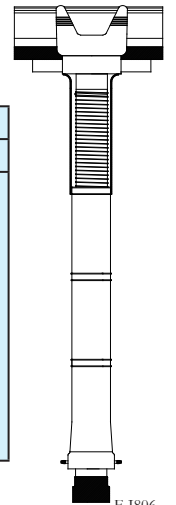

F-1806

DIAGRAM #3
RAIL IS > 17'6" AFF.
If the bottom of the Apex Rail is more than 17'6" AFF, contact your representative to arrange straps of a custom length. With this arrangement, some exhaust hose from the Vacuum Holster™ will be visible.

Step #1: Suspension of Apex Rail Aluminum Profile

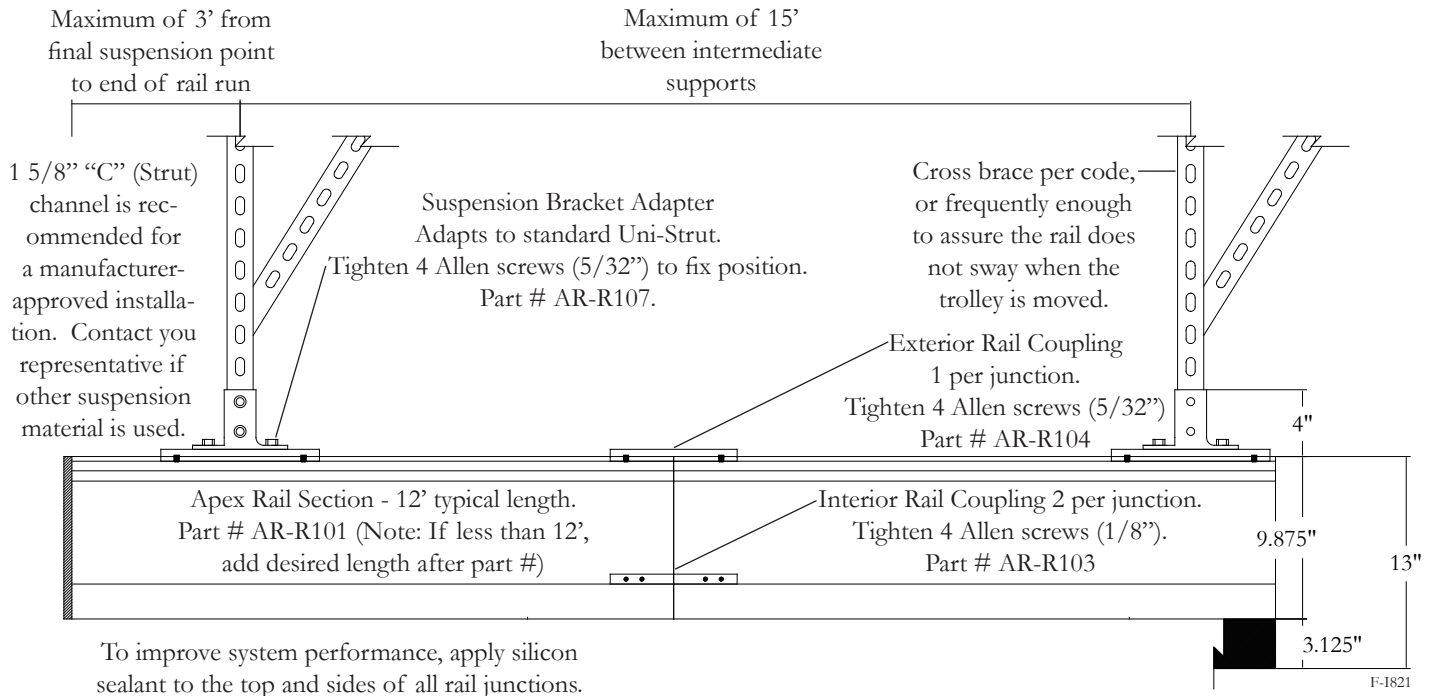

DETAIL - SUSPENSION BRACKET ADAPTER

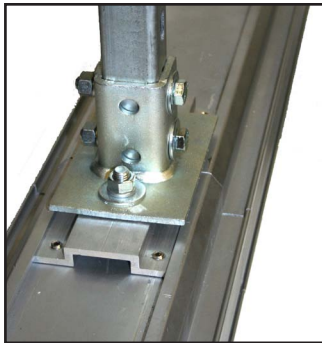

I-AR107-01

Suspension Bracket Adapter Part # AR-R107

- Adapts to 1 5/8" Unistrut
- Slides along the top channel of the Apex Rail for easy placement
- Tighten 4 Allen screws (5/32")
- Suspension point is required 3' or less from each end of a run of rail, and 15' or less for intermediate supports

DETAIL - EXTERNAL RAIL COUPLING

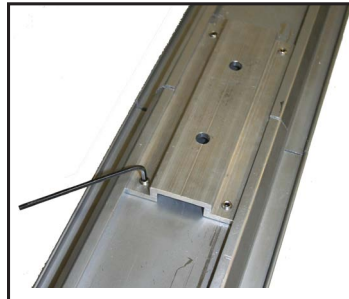

I-AR104-01

External Rail Coupling Part # AR-R104

- 1 per rail junction
- Insert coupling into pocket on top of rail, with 2 Allen screws on each rail
- Tighten all 4 Allen screws (5/32") to fix position

DETAIL - INTERNAL RAIL COUPLING

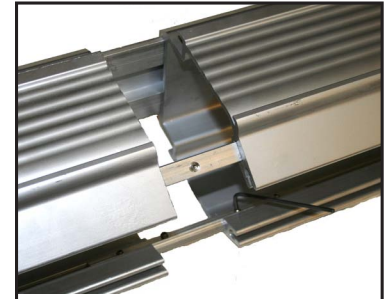

I-AR103-01

Internal Rail Coupling Part # AR-R103

- 2 per rail junction
- Insert coupling into pocket on interior of rail, with 2 Allen screws on each rail
- Tighten all 4 Allen screws (1/8") to fix position of rail

Step #2: Installation of Rubber Seals and Sliding Trolleys

Rail End Cap.
2 per rail system.
Install with 4 self-tapping screws and seal with silicon.
Part # AR-R113.

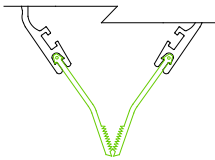
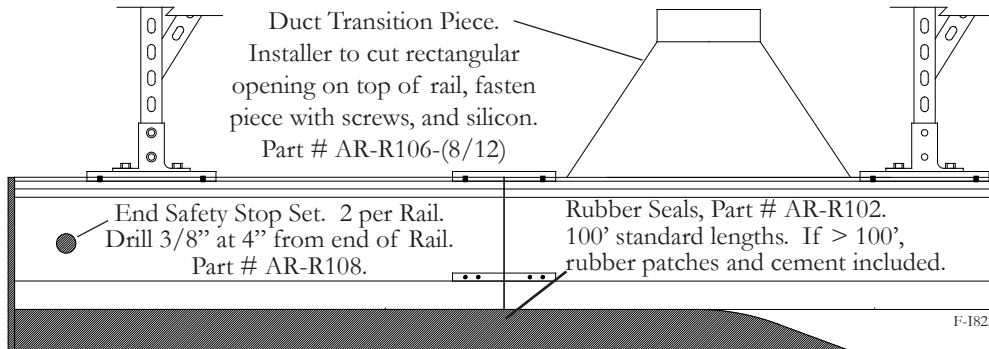

Grooves on rubber seals face inward.

Begin by installing the rubber seal at the end of the rail. Applying silicon lubricant to the rubber seal and rail channel will greatly facilitate the process. A steady push upward will lock the rubber into the channel; ensure the mushroom head decompresses in the channel opening, securing the rubber seal in the aluminum channel.

Tip #1: Installation is easiest with two people, on a scissor lift.

Tip #2: One installer should hold the soon-to-be-inserted rubber seal taut, and at the same angle with the already-installed rubber; the other installer should lock the rubber seal into the channel (see images above).

DETAIL - SLIDING TROLLEY AND VACUUM HOLSTER™

After the Apex Rail and has been suspended, the sliding trolleys can be installed on the rail profile.

Though checked for smooth rolling at the factory, the trolleys have adjustable wheels if binding occurs in the field.

As mentioned on page 2, the bottom rim of the tailpipe adapter is recommended to be 6'3" AFF. Ideally, the bottom of the aluminum profile is 14'6" AFF.

The Vacuum Holster™ is attached to the sliding trolley by two flexible straps. As shown above, these are shipped in 3' lengths, with holes pre-punched every 3".

If the bottom of the aluminum profile is between 14'6" and 17'6", select the pair of pre-punched holes that attain the desired clearance, and trim the excess, as shown at right.

If the bottom of the rail is suspended lower than 14'6", use the short-est strap and field-cut the Holster (up to 22").

If the rail is more than 17'6" AFF, contact your representative to obtain straps of a custom length.

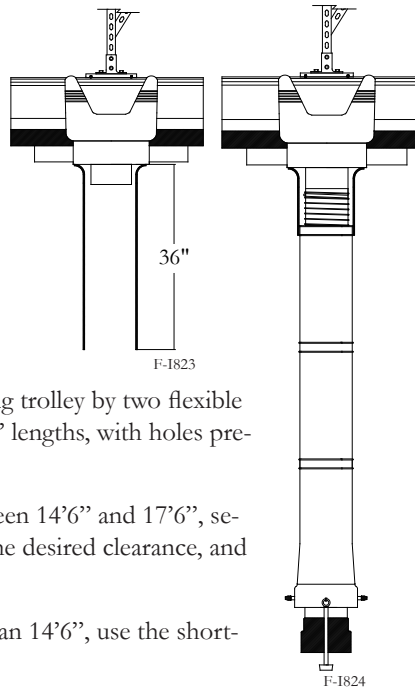

Alignment Considerations:

When stored in the Hose Holster, the axles of the tailpipe adapter should be parallel to the Apex Rail.

Also, the tug strap (and optional remote start transmitter) should point toward the service bays, and not the center drive.

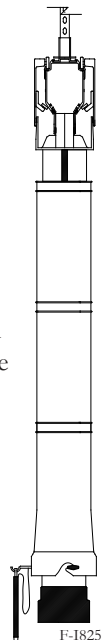

Step #3: Installation of Accessory Items and Troubleshooting Guide

SECURING THE RUBBER SEALS

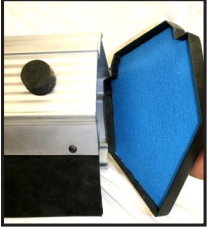

I-ARHC-08

Ensure rubber seal is flush with the end of the rail.

Install the rubber seal so that it is flush with the end of the rail. If not, there will not be an airtight seal with the end cap once it is installed.

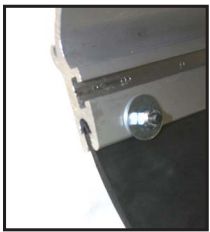

I-ARHC-07

Fasten the rubber seals in this flush position.

2" from the end of the rail, drill a 5/16" hole through the rail and rubber seal as shown, and install the provided hardware. These bolts will prevent the rubber from relaxing and moving after installation.

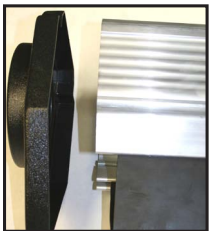

I-ARHC-06

Incorrect -

If the rubber seal is not flush with the end of the rail, the system will not seal once the end cap is installed. Also, without the bolts, the rubber seals will creep inward after installation.

SAFETY STOPS



I-ARHC-01

**End Safety Stops
Part # AR-R107**

- Drill 3/8" hole at 4" from the end of the rail, anywhere along the main vertical surface
- Install spacer between rubber cushion and exterior surface of Apex Rail; nut and lock washer on the interior of the Apex Rail

END CAPS



I-ARHC-05

**End Caps
Part # AR-R113**

- Fasten to Apex Rail with four self tapping screws. The end cap is pre-drilled to ensure correct location of the screws.
- Seal the perimeter of the end cap with silicon sealant.

TUG STRAP



I-ARSC-09

**Holster Tug Strap
Part # AR-R109**

- A hole is pre-drilled in the lower rim of the Hose Holster, 90 degrees from the tee handles
- Install with provided hardware, ensuring fender washers are on interior and exterior of Hose Holster.
- Tighten, making sure hook is up
- The remote start transmitter (if ordered) is pre-assembled with tug strap

TROUBLESHOOTING: POOR EXHAUST HOSE RETRACTION

- 1) Confirm that the rotation of the exhaust fan is correct.
 - 2) See if any debris has accumulated on the birdscreen outlet piece of the exhaust fan.
 - 3) Check for pressure loss arising from unsealed rail, end caps, and ductwork.
 - 4) Confirm that dampers are closed on inoperative Vacuum Holsters™.
 - 5) See if the rubbers seals and end caps are correctly installed.
 - 6) Confirm that the exhaust fan is wired for the correct voltage/phase so that it attains its nameplate rpm.
 - 7) Ensure the exhaust fan is turned on, to provide the assistance in retraction.
- Note: The system is designed for the hose retraction to be fan assisted (not fan automatic), and will require a degree of guidance from the technician.

TROUBLESHOOTING: BINDING OF SLIDING TROLLEY

- 1) Check if the top of side alignment wheels have proper settings, and adjust if not.
- 2) See if the rail sustained freight/installation damage and is too wide or narrow at some point along its length.
- 3) At all rail joints, ensure the internal and external couplings are properly installed, that the rail sections are level, and are in proper alignment.

Dimensions and Weights, High Capacity Apex Rail

APEX RAIL PROFILE

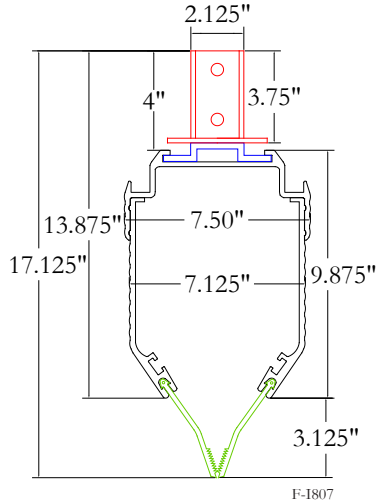

VACUUM HOLSTER™

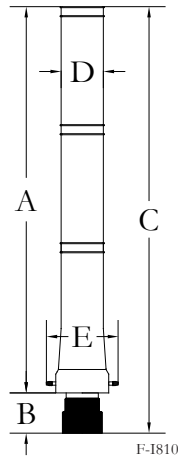

Dimensions, Vacuum Holster		
6" Holster	Holster Model	
	Compact	Extended
A	50"	72"
B	7 1/2"	7 1/2"
C	63 1/2"	85 1/2"
D	7 7/8"	7 7/8"
E	14"	16 3/4"
8" Holster	Holster Model	
	Compact	Extended
A	50"	72"
B	8 1/2"	8 1/2"
C	64 1/2"	86 1/2"
D	9 7/8"	9 7/8"
E	16 3/4"	16 3/4"

6/8" TROLLEY - END VIEW

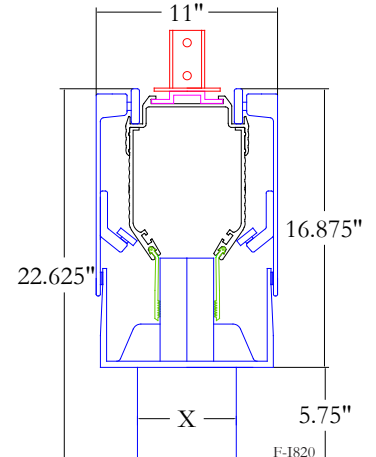

Note: "X" equals hose diameter.

6-8" TROLLEY - SIDE VIEW

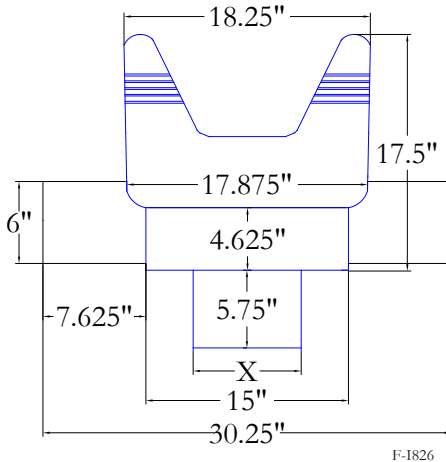

Note: "X" equals hose diameter.

Weight - High Capacity Apex Rail

Apex Rail Profile, lineal foot* 10.8 lbs

* The above weight includes accessories such as rubber seals, couplings, etc

Weight - Trolley Assembly

Trolley Assembly - 6" 38 lbs

Trolley Assembly - 8" 45 lbs

Weight - 6" Vacuum Holster™

Holster Model	Compact	Extended
17' Exhaust Hose	38 lbs.	41 lbs.
20' Exhaust Hose	41 lbs.	44 lbs.
25' Exhaust Hose	n/a	49 lbs.

Weight - 8" Vacuum Holsters™

Holster Model	Compact	Extended
17' Exhaust Hose	53 lbs	57 lbs
20' Exhaust Hose	56 lbs	60 lbs
25' Exhaust Hose	n/a	66 lbs

Note: Vacuum Holsters™ include tailpipe adapter, exhaust hose, and Hose Holster.

INCLUSIONS/EXCLUSIONS

To prevent misunderstanding concerning installation supplies, Ascent Systems does not typically furnish the following: exhaust duct, sealant, or duct suspension straps; angle iron, Unistrut, beam clamps, or other bracketing/bracing material; roof curbs, wall brackets, or other means of mounting the exhaust fan.

Ascent Systems does supply the exhaust fan with an outlet piece and R-I-S isolators, the Vacuum Holster™ hoses, and the rail components as shown on page 1.