

# Best Side Glass

## OVERVIEW

### Side-Folding Horizontal Gates

Security While Maintaining an Open Appearance

Best Side-Folding Doors are available in a range of patterns and finishes - Folding gates provide security & ventilation. The most notable feature is the ability to visually observe what is behind the door when fully closed. Ideal for areas that have no headroom as gate can be tucked neatly into a side housing unit.

## SPECIFICATIONS

### CURTAIN

Curtain is constructed of 6" (152mm) wide modules linked together by a continuous aluminum hinge. These hinges hold tempered glass panels 1/8" (3mm) thick and 4-3/4" (121mm) wide. Each glass panel is protected at its perimeter by a vinyl extrusion recessed within the full height of the hinges.

### LOCKING

- A. Lead post shall be equipped with a 7-pin Master-Keyable cylinder lock.
- B. Lead post shall engage a full height wall jamb.
- C. Trailing post shall be self-locking at the top and bottom inside the storage pocket.
- D. Free floating intermediate posts shall be located at all curves and at recommended intervals of 10 feet (3m) or 5 feet (1,5m) for counter top units. Intermediate posts shall be equipped with self-adjusting spring loaded drop bolts activated from the inside only. Drop bolts shall engage dust-proof stainless steel receptacles.

### TRACK

- A. Curtain shall be hung from an overhead track 1-5/16" (33mm) wide by 1-9/16" (40mm) high. Track shall be tempered aluminum alloy 6351-T6.
- B. Curves where required shall be 14" (356mm) radius standard.

### STACKING

Stacking shall not exceed a depth of 1.15" per foot of closure width plus 3" for each post (lead, end or intermediate). (95mm/lin. m + 76mm per post). Full egress doors add 7" (178mm).



### FINISH

Finish shall be standard clear anodized or paint in white, black or bronze.

Following options are available if modifications or improvements are required:

### LOCKING OPTIONS

- Top and bottom locking posts with key cylinders one or both sides are available for either end of the curtain.
- Large sections may be divided by incorporating bi-part units as intermediate posts.
- Second hook bolts on lead, end or bi-parts (Recommended for closures over 12' (3,7m) high or for more security).
- Solid aluminum block covering cylinder lock for additional protection (Specify guard cylinder protection).
- Architect to decide side of lock cylinders.
- Additional intermediate post with shoot bolt to floor or counter.

### TRACK CURVES

- 10" (254mm) radius curves (Indicate location on plans).
- Special radius curves (Indicate location and radius on plans).

### EGRESS COMPLIANCE

- Full egress door 36" x 80" (914mm x 2032mm) where required by local building code.

## CONTACT US

Best Rolling Manufacturer, Inc. P: 305-698-3550  
9780 NW 79 Avenue F: 305-698-3552  
Hialeah Gardens, FL 33016 www.bestdoor.us

# Best Side Glass

## Details - Typical Scenario Model - Side Folding Gates

### ELEVATION

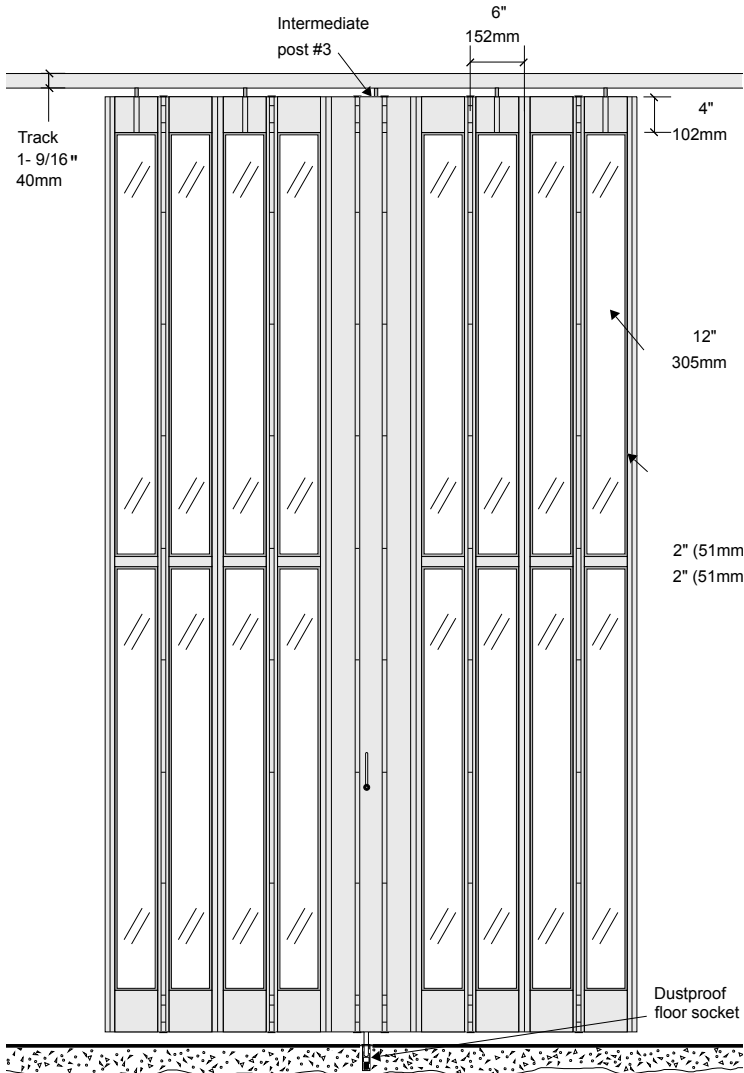

### COMMON FINISHES

Panels:

Spacers:



Tempered Glass



Silver



White



Black



Bronze

Consult for availability. Powder Coated colors available upon request.

### TYPICAL LAYOUT

For further options, consult factory.

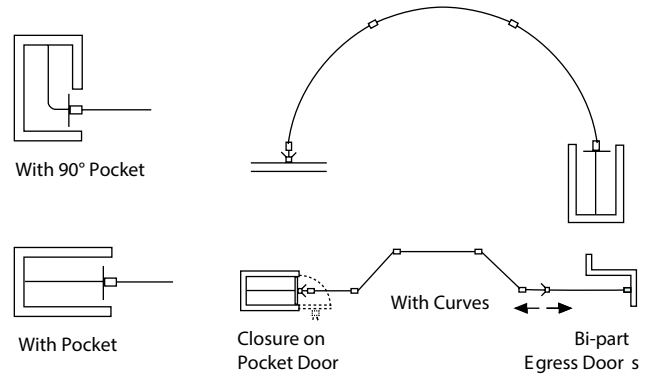

### VERTICAL SECTION

