



County of Meade
Sturgis, South Dakota
Building – Code Enforcement

Asphalt Shingles Re-Roofing

Remove or tear-off existing roofing materials

- Placing new roofing over existing roofing is **NOT PERMITTED** when using asphalt shingles, slate, clay, asbestos cement tiles or wood shake shingles. The International Building Code-International Residential Code requires that the existing roofing materials are to be removed **BEFORE** the new roofing materials are placed.

Roof decking or sheathing

- The wood roof decking must be examined **BEFORE** re-roofing and repairs are made to the structure and if found damaged, rotted or unsound, that area of roof decking must be replaced.
- Check the building code requirements before replacement.

Fasteners

- Asphalt shingles must have the minimum of fasteners as required by the manufacture of the product you purchased.
 - For normal application up to a 20/12 pitch, a minimum of 4 fasteners is required per strip shingle and 2 fasteners for an individual shingle.
 - For roof pitches exceeding 20/12 pitch, special methods of fastening the shingle per the manufactures instructions.
- **Nails** must not be less than 12 gauge shank with a 3/8 diameter head.
- **Nails** shall be sufficient lengths to penetrate through the roofing material and at least 3/4 of an inch into the roof decking or through the thickness of the decking; whatever is less.

Underlayment

- 2/12 to less than 4/12 pitch must have 2 layers of 15 lb. felt (tarpaper) applied in a shingle fashion. Start with a 19 inch wide sheet and a 36 inch wide sheet over at the eaves, each subsequent sheet shall be lapped 19 inches horizontally and 4 inches vertically. All end laps shall be offset by 6 feet.
- 4/12 and over roof pitch shall have 1 layer of 15 lb. felt (tarpaper) lapped 2 inches horizontally and 4 inches vertically. All end laps shall be offset 6 feet.

Ice/Water Barrier

- An Ice/Water Barrier is required on both the house and attached garage roof. An Ice/Water Barrier that consists of at least two (2) layers of underlayment cemented together or of a self-adhering polymer modified bitumen sheet, shall be used in lieu of normal underlayment and extend from the eave's edge to a point **AT LEAST 24** inches inside the exterior wall line of the building. Typically, two (2) rows (6 feet) of Ice/Water Barrier are required, but more than two (2) rows may be required depending on the size of the soffit overhang. The underlayment must extend to the outer edge at all fascia boards. See the manufacture's installation instructions. Ice/Water Barrier is not required on detached accessory structures with no conditioned floor area.

Crickets and Saddles

- A cricket or saddle shall be installed on the ridge side of any chimney greater than 30 inches wide. Cricket and saddle covering shall be sheet metal or of the same materials as the roof covering.

Valley Flashing

- When any existing flashing is corroded (rusted), damaged or deteriorated, it shall be replaced. Valley flashing shall consist of not less than No. 26 galvanized sheet gauge corrosion resistant metal or equal. The metal shall extend at least 12 inches from the centerline each way. Valley linings shall be installed in accordance with the manufactures instructions.

Sidewall Flashing

- When an existing flashing is corroded (rusted), damaged or deteriorated, it shall be replaced. Flashing against a vertical sidewall shall be by the step-flashing method.

Other Flashing and Vents

- Flashing against a vertical front wall, as well as a soil stack, vent pipe and chimney flashing shall be applied according to the asphalt shingle manufacturer's instructions.

- Care should be taken to insure that the kitchen and bathroom exhaust fan pipes are connected to the appropriate damper exhaust roof vent with no openings into the attic that would allow exhaust air back into the attic space. The exhaust vents should be installed on the roof the same as other attic vents and other vent pipe flashing.

- When re-roofing around furnace flues, take care to not dislodge the joints of the flue pipe within the attic or within interior chases this pipe may pass through. If in doubt, please call.

PROTECTIVE ICE BARRIER

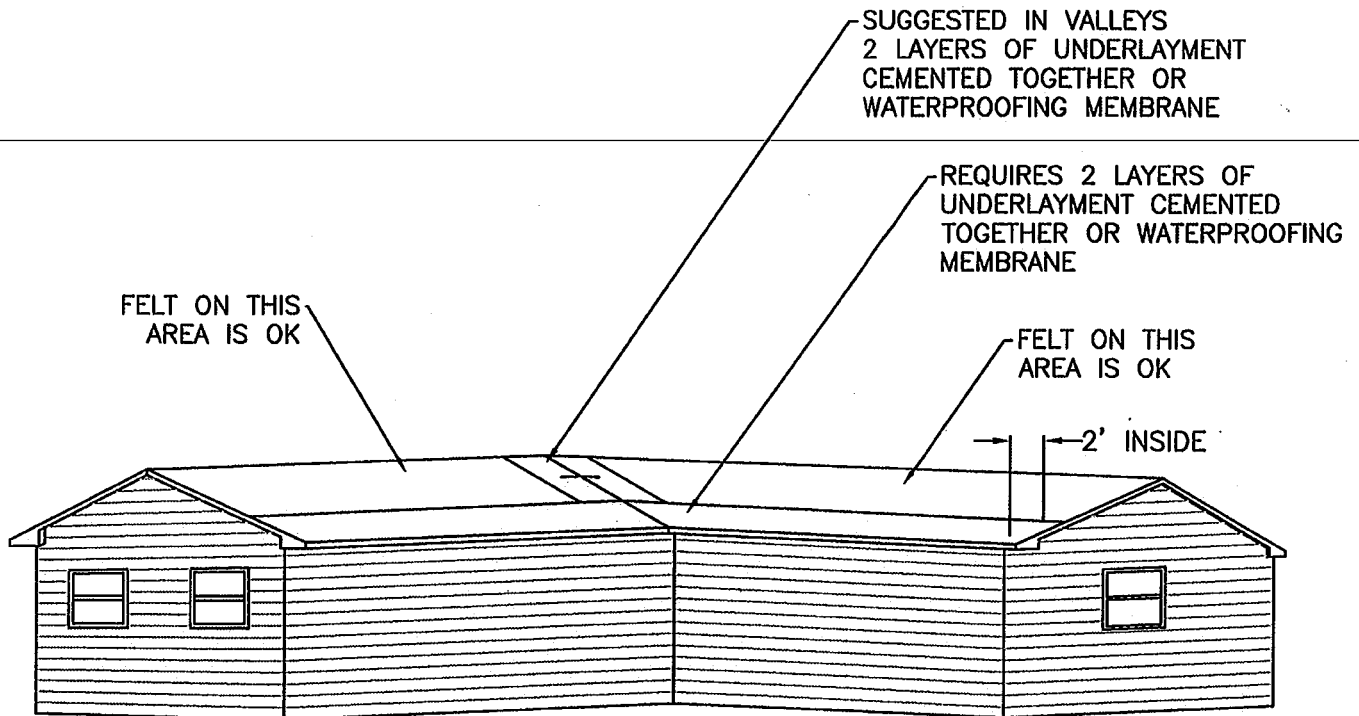
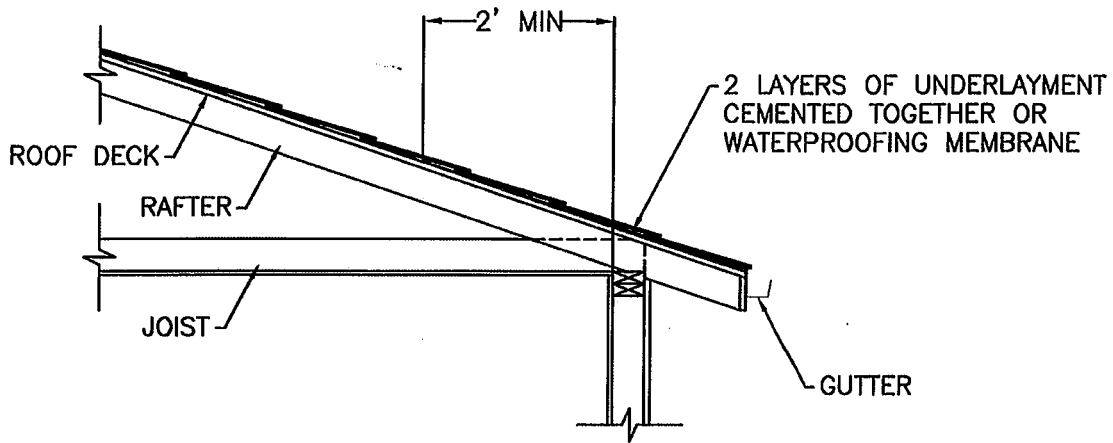

- Minimum 1 hail day/20 years, Moderate Size (1.5 - 5.0 in.)
- Minimum 1 hail day/20 years, Severe Size (2.0 - 5.0 in.)

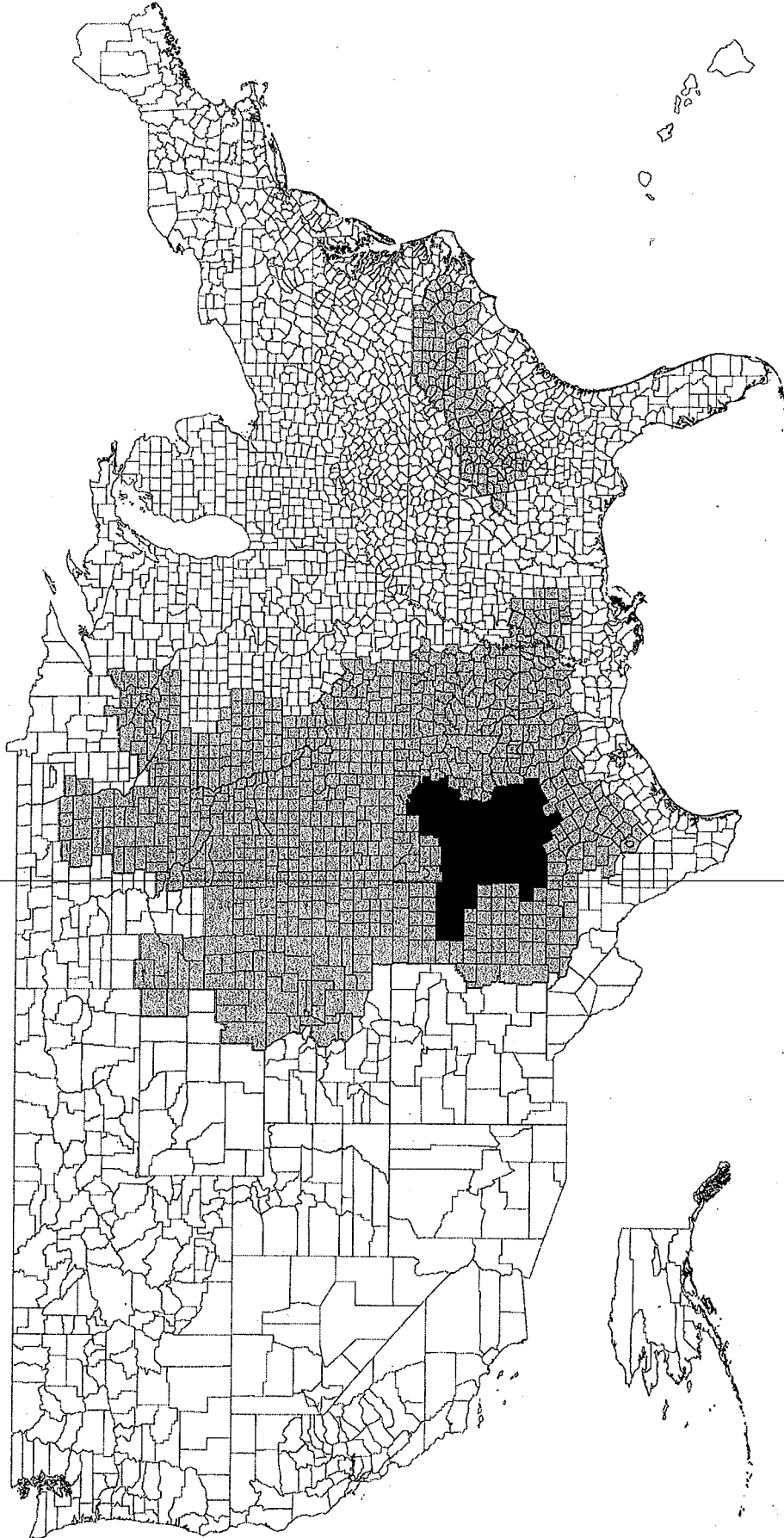

FIGURE R903.5
HAIL EXPOSURE MAP