

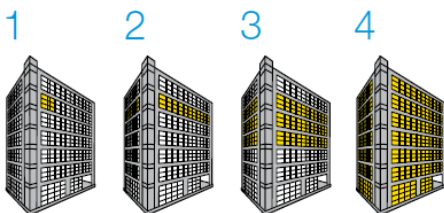

Vive control system- a simple, flexible, and scalable lighting control solution comprised of a full family of wireless devices that can be tied together with Utopia Lighting products, enabling centralized monitoring and system integration. It is a modular wireless lighting control solution for new and existing buildings - K-12 schools, Commercial and Government offices, and colleges and universities - and can help to meet stringent energy codes and improve building performance on budget and on time. Unlike traditional wired lighting control solutions of labor-intensive disruption and complexity, Vive lighting control system can be installed 70% faster. Lutron's patent pending RF signal strength detection automatically finds nearby devices making job setup faster. Thus, saves labor costs, minimizes disruption, and enables to decrease energy consumption costs for infrequently used spaces.



**START SMALL AND GROW**

The scalable capabilities of Vive Wireless allows you to start of project with one room or space, and expand at any time without requiring redesign or manufacturer start-up.



**REDUCE RISK**

Simple, intuitive programming allows flexible programming, minimizing risk during the project life cycle. With wireless communication at each fixture, the electrical contractor or facility team can easily modify zoning and sensing options for an individual fixture or group/area of fixtures with a few clicks from any mobile device.



## DESIGN

The flexibility you need to design your building.  
Solutions for every space and budget.



### Personalize control

The Vive wireless product family lets you personalize control in each space in your building without locking into more or less control than you need for any load and control type.

### Limitless

The Vive wireless enables to combine individual fixture and area control.  
You can expand the system at any time by such as adding control options and new areas.



## INSTALL

Wireless simplifies installation and reduces callbacks.



### 70% Faster

With Vive wireless products, you can install a switch and sensor in as little as 15 minutes.

### Simple setup

Mobile phone setup using Vive Vue software on any compatible smart device.

### Eliminate callbacks

Lutron offers a variety of flexible, scalable support options to meet the needs of your project and your budget.



## MAINTAIN

Maximize productivity and building performance.



### Monitor

From any smart device, you can easily adjust the lighting control to accommodate building churn, improve occupant comfort, and enhanced energy-efficiency.

### BACnet protocol

With simple integration, you can connect with other building systems using BACnet protocol at the time of initial installation, or whenever you expand the system. (Embedded or native in the Vive Hub - no external interface or gateways are required in order to communicate with other systems.)

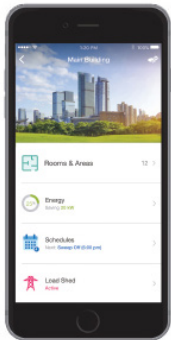

- Building/ Energy Management Systems (BMS/EMS)
- HVAC
- IT
- Audio & Video
- Energy Dashboards and Analytics Packages

**Adjust** - With simple to use, intuitive software, the ability to save energy and improve building performance is at your fingertips.



### Energy Reporting

Quickly view and display energy-usage information to drive decision making and demonstrate savings.



### Load Shed

Easily set lighting reduction levels that automatically respond during peak electricity usage times



### Schedules

Use a 365 day calendar to automatically adjust lights based on time of day, including single day and holiday events.



### Light Control

Directly adjust the light levels.



(Vive Hub is required to install the Vive software)

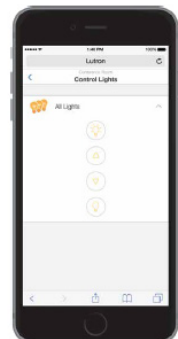
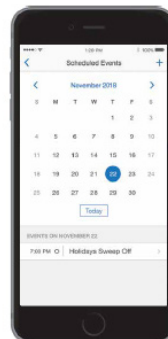
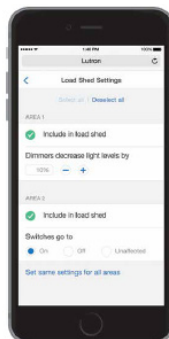
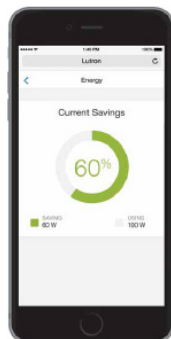

**Expand**  
Scalable solutions

**Start small and grow**

Vive wireless solutions offer a completely wireless, multi-strategy approach, that accommodates your budget and performance needs now and for the future of your building.

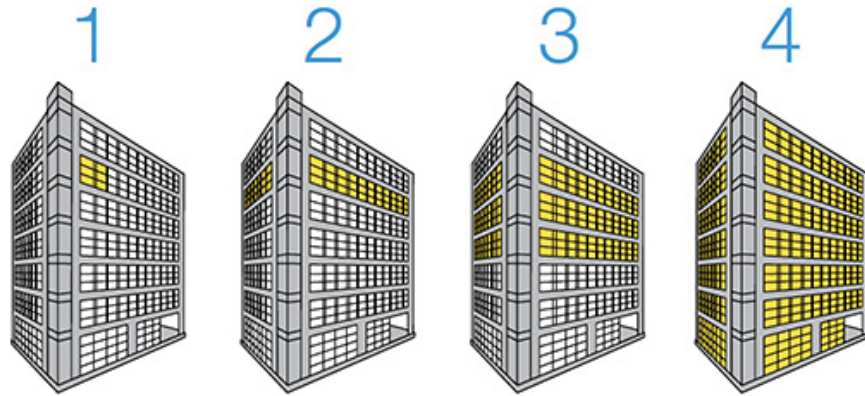

**Single Office Space**

Start by adding control in a single space as budgets and occupant schedules allow.

**Single Floor**

Expand to new areas or an entire floor at any time without re-programming or replacing equipment.

**Multiple Floors**

Duplicate the success of one floor across other floors as your business expands or tenants change. Control can be independent on each floor, or linked via Vive wireless hubs.

**Entire Building**

Duplicate the success of one floor across other floors as your business expands or tenants change. Control can be independent on each floor, or linked via Vive wireless hubs.

**Load Controllers: Wireless individual fixture control (supplied by Utopia Lighting)**

Vive Integral fixture control for each fixture in the space.



**DFCSJ-OEM-OCC**  
(Clear Connect (RF) + Sensing)

Dimensions  
W: .927" (23.5mm)  
H: 2.577" (65.4mm)



**DFCSJ-OEM-RF**  
(Clear Connect (RF) Only)

Dimensions  
W: .827" (21mm)  
H: 2.477" (62.9mm)

**HOW TO DESIGN AND SPECIFY**

- **Vive integral fixture control** for each fixture in the space.
- **Digitally controls** up to three drivers/ballast per fixture.
- **Select either** Clear Connect (RF) only or Clear Connect (RF) & XCT Sensing.

**PRODUCT OPTIONS**

**Wireless individual in-fixture control**

**DFCSJ-OEM-RF** : Clear Connect (RF) only  
**DFCSJ-OEM-OCC** : Clear Connect (RF) and Occupancy/Daylight Sensing.

Contact your local fixture representative and ask for a Vive-enabled fixture or visit [lutron.com/findafixture](http://lutron.com/findafixture).

\*NOTE: Wireless sensors and controls must be located within 60 ft (18m) line of sight, or 30 ft (9m) through walls of each other.

**Fixture Sensor coverage diagrams**

Applies to both products

**Clear Connect (RF)**



Pico Remote Control (Up to 10)

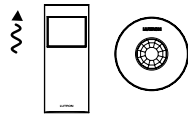

Radio Power Savr Occupancy sensor (Up to 10)



Radio Power Savr daylight sensor (Up to 10)

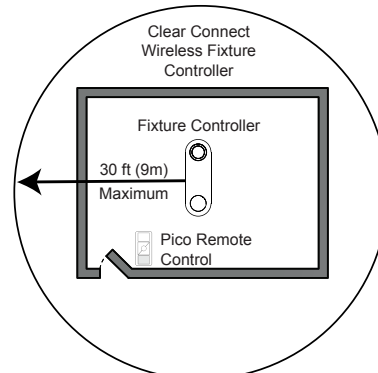

**Vive PowPak wireless fixture control for each fixture in the space**



**FCJS-010  
FCJS-ECO**

Dimensions  
W: 3.368" (86mm)  
H: 3.94" (100mm)  
D: 1.25" (32mm)

**Ceiling Mount  
Occupancy/Daylight  
sensor**

Sensor Dimensions  
W: 2.89" (48mm)  
H: 3.44" (87mm)  
D: 1.25" (32mm)

**HOW IT WORKS**

Install the fixture control directly to a fixture or a junction box nearest to the fixture.  
To optimize coverage in the designed area, install the sensor on the ceiling near the fixture.

\*NOTE: Avoid mounting the fixture sensor in direct sunlight or in the light which is cast from the fixture.

**HOW TO DESIGN AND SPECIFY**

- One PowPak Wireless Fixture Control for each fixture in the space.
- Controls 1A of load or up to three drivers/ballast per fixture.
- Select either Area sensing or individual fixture sensing.
- PowPak fixture sensor : Combined occupancy/daylight sensor.

**PRODUCT OPTIONS**

**0-10V control models**

- FCSJ-010
- FCSJ-010-BULK : 8-pack

**EcoSystem control models**

- FCSJ-ECO
- FCSJ-ECO-BULK : 8-pack

**Sensor models**

- FC-SENSOR : Occupancy/Daylight sensor
- FC-VSENSOR : Vacancy/Daylight sensor

**XCT Occupancy/Vacancy sensing**

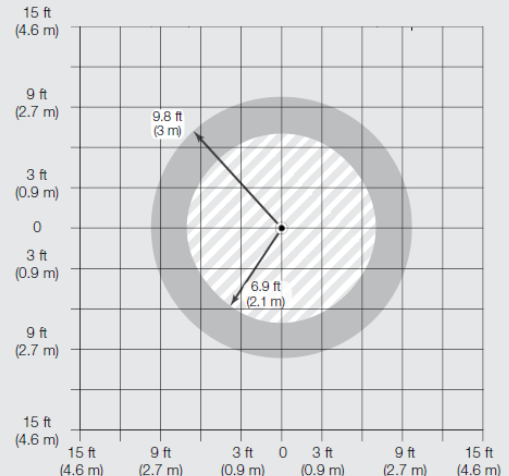
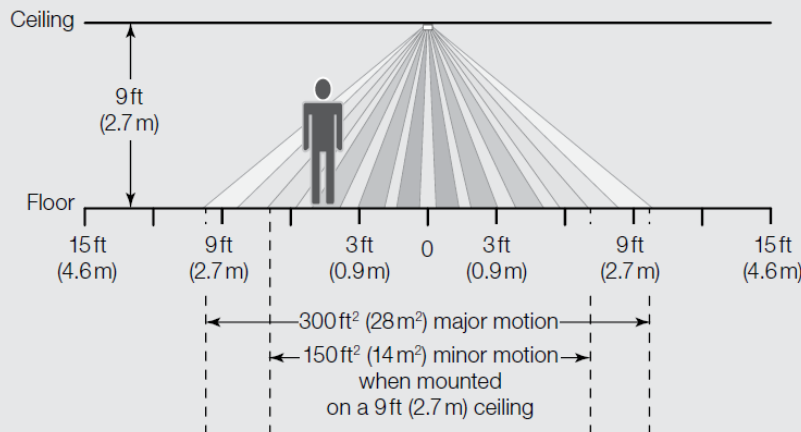

**Load Controllers: UL 924 rated emergency wireless controls (Supplied by Utopia Lighting)**

**Vive PowPak UL 924 emergency lighting modules**



**FCJS-010-EM  
FCJS-ECO-EM**

Dimensions  
W: 2.89" (48mm)  
H: 3.44" (87mm)  
D: 1.25" (32mm)

**HOW TO DESIGN AND SPECIFY**

- One UL 924 PowPak module per lighting zone or fixture, depending on model.

**Relay module control:**

- 16A: 1920W or 1/2 HP @ 120V
- 4432W or 1/2 HP @ 277V

**0-10V module control:**

- 8A: 0-10V controlled fixtures and switches compatible with third-party 0-10V fluorescent ballast, LED drivers, and fixtures
- 0-10V link: Communicates with up to 60mA of fixtures

**Fixture control:**

- 1A of load or up to 3 drivers and ballasts

**Input (all models): 120/277V**

**PRODUCT OPTIONS**

**Relay : RMJS-16R-DV-B-EM**

**0-10V : RMJS-8T-DV-B-EM**

**Fixtures : FCJS-010-EM, FJJS-ECO-EM**

**HOW IT WORKS**

During normal power conditions, the UL 924 rated PowPak modules can dim loads and respond to local button presses, Pico wireless controls, and occupancy/daylight sensors.

If utility power fails and the emergency PowPak loses power for greater than 250 msec, the emergency generator back-up source activates and the automatic transfer switch senses loss of normal power and switches to emergency power.

The emergency PowPak regains power and automatically goes into emergency mode (full output, relay closed and 0–10 V- signal goes to 10.0 V-) for 90 minutes. All local buttons, Pico wireless controls and occupancy/daylight sensors will not respond.

When normal power is restored to the Vive hub and emergency PowPak, the emergency PowPak will return to the previous light level within 2 minutes of normal power being restored. It will again accept local button control, input from Pico wireless controls, and occupancy/daylight sensors

**System Wiring Diagram (Vive Hub with Emergency PowPak)**

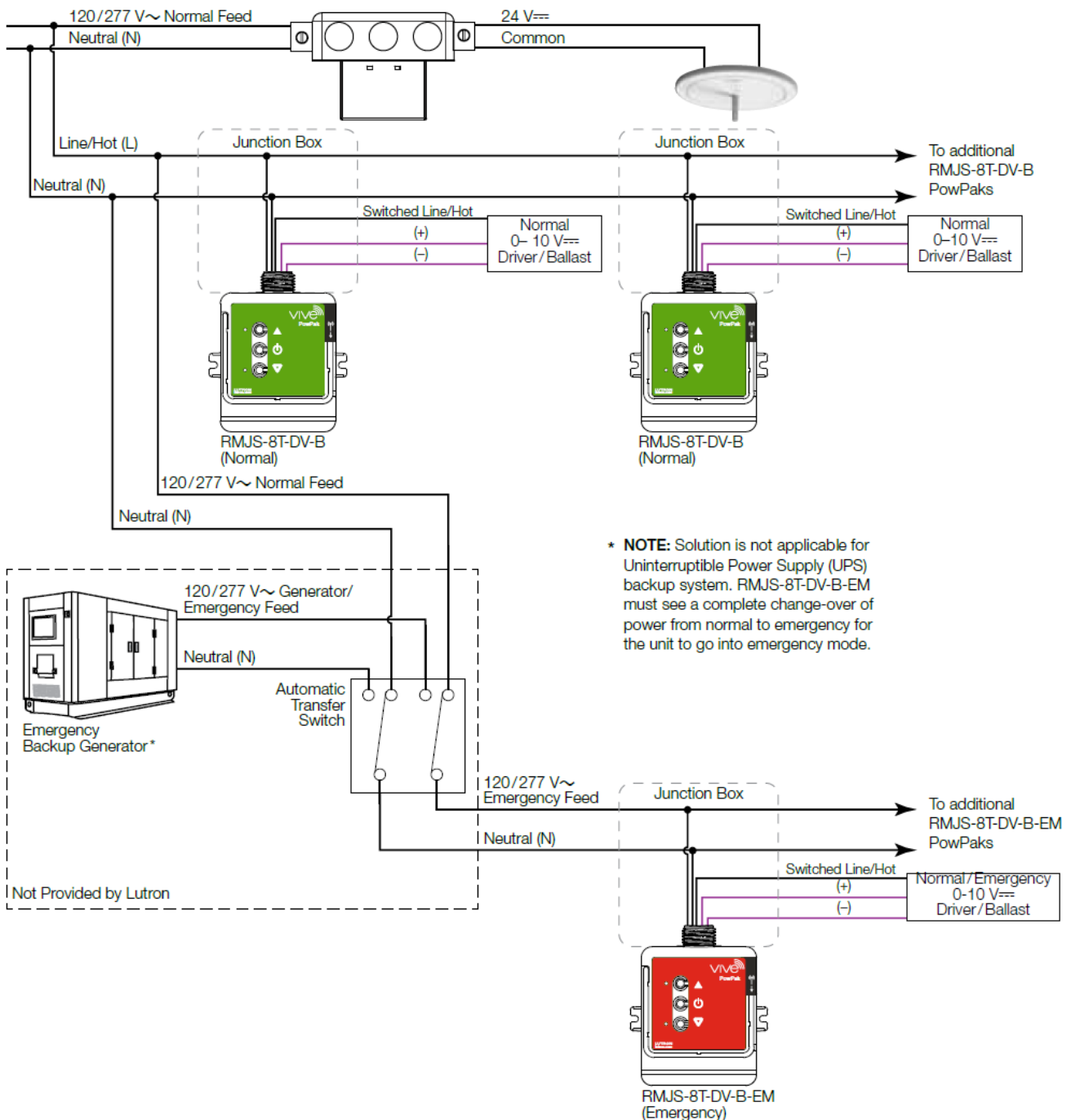

## Vive Wireless Hub (Supplied by Lutron distributor)



### Vive wireless hub

Dimensions  
 W: 6.5" (165mm)  
 H: 1.5" (38mm)  
 D: 2.8" (71mm)



### Vive hub power supply

Dimensions  
 W: 4.0" (102mm)  
 H: 1.7" (43mm)  
 D: 2.8" (71mm)

### FEATURES AND BENEFITS

- Communicates with controls on a floor using Lutron wireless. Clear Connect technology (range radius of 71 ft [22 m])
- Distributed system architecture. Pico remote controls and sensors communicate directly with the load devices they control and must be located within 30 ft (9 m) of the device with which they are associated.
- Supports timeclock events based on both sunrise and sunset or fixed time-of-day.
- Integrated multi-color LED provides feedback on what mode the hub is in.
- Two contact closure Inputs for integration with devices by others including devices for Title 24 Automatic Demand Response.
- Each hub provides an individual dashboard for its coverage area and allows you to link to other hub dashboards from the mobile application

### PRODUCT OPTIONS

#### Vive wireless hub models

**Starter (up to 75 devices)**  
 - HJS-0-FM : Flush mount

**Standard**  
 - HJS-1-FM : Flush mount  
 - HJS-1-SM : Surface mount

**Premium (with BACnet)**  
 - HJS-2-FM : Flush mount  
 - HJS-2-SM : Surface mount

\*Note: A minimum distance of 10 ft (3 m) between Vive wireless hubs on the same floor is required.

\*Note: A corporate Wi-Fi network can interfere with the Wi-Fi on the Vive wireless hub. Where a corporate Wi-Fi network exists, it is recommended to do one of the following:  
 1) Connect to the Vive wireless hub and change the Wi-Fi channel to one that isn't used by the corporate network or  
 2) Connect the Vive wireless hub to the corporate network using the Ethernet connection on the hub, and disable the hub's Wi-Fi.

\*Note: Vive wireless hub must be mounted a minimum of 10 ft (3 m) from a Wi-Fi router or access point.

### HOW IT WORKS

All wireless devices to be associated to the Vive wireless hub must be within 71 ft (22 m) of the Vive wireless hub and must be on the same floor as the Vive wireless hub.

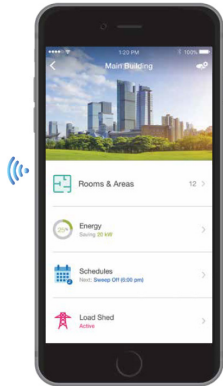

Lutron's Vive Software  
 (Use any WIFI enabled device)

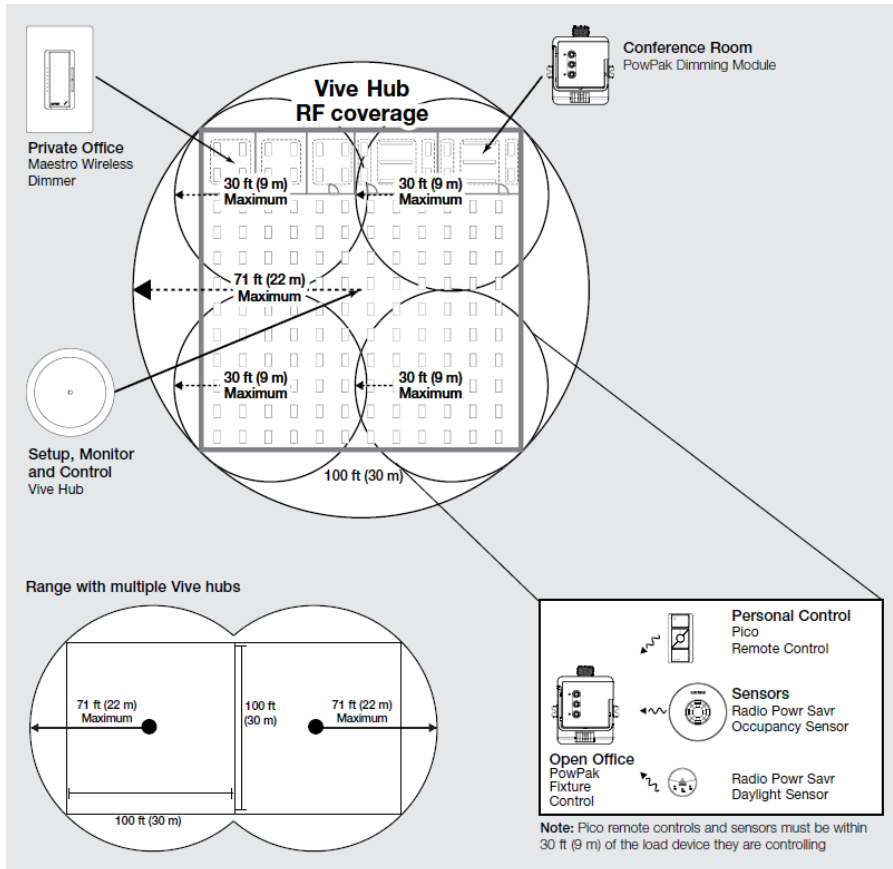

**Sensors: Ceiling occupancy/vacancy sensor (Supplied by Lutron distributor)**



**Wireless occupancy/vacancy sensors**

Dimensions  
 W: 3.57" (91mm)  
 H: 3.57" (91mm)  
 D: 1.13" (29mm)

**HOW TO DESIGN AND SPECIFY**

- A single occupancy sensor can communicate to all control devices in the room
- Use in small rooms or areas with medium to high partitions
- For 8 ft ceilings: 484 ft<sup>2</sup>
- For 12 ft ceilings: 676 ft<sup>2</sup>

**PRODUCT OPTIONS**

- Ceiling-mount sensors**
- LRF2-OCR2B-P-WH : Occupancy / Vacancy
  - LRF-2-VCR2B-P-WH : Vacancy only

- Accessories**
- L-CMDPIRKIT : Ceiling-mount sensor lens masking kit
  - L-CRMK-WH : Ceiling-mount sensor recess-mount bracket
  - L-WIRECAGE-C : Wire guard for ceiling-mount sensor

**Sensor coverage diagram**

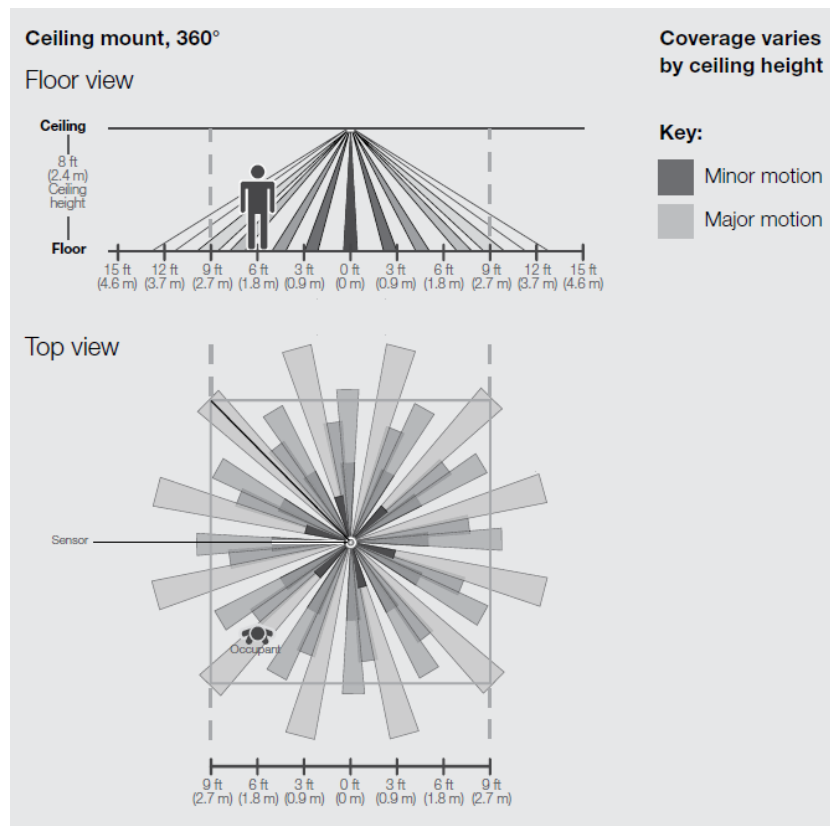

**Ceiling-mount sensor coverage chart (for sensor mounted in center of room)**

Ceiling height	Maximum room dimensions for complete floor coverage	Radius of coverage at floor
8 ft (2.4m)	18 x 18 ft (5.5 x 5.5m) 324ft <sup>2</sup> (30.2m <sup>2</sup> )	13ft (4.0m)
9 ft (2.7m)	20 x 20 ft (6.1 x 6.1m) 400ft <sup>2</sup> (37.2m <sup>2</sup> )	14.5ft (4.4m)
10 ft (3.0m)	22 x 22 ft (6.7 x 6.7m) 484ft <sup>2</sup> (44.9m <sup>2</sup> )	16ft (4.9m)
12 ft (3.7m)**	26 x 26 ft (7.9 x 7.9m) 676ft <sup>2</sup> (62.4m <sup>2</sup> )	19ft (5.8m)

\* Sensor mounting shown at 7 ft (2.1 m). Mounting height should be between 6 and 8 ft (1.6 and 2.4 m).  
 \*\* 12 ft (3.7 m) is the maximum mounting height allowed.

**Sensors: Wall-/Hall-/Corner-mount occupancy/vacancy sensors(Supplied by Lutron distributor)**



**Radio Powr Savr  
Wireless sensors**

Dimensions  
W: 1.8" (46mm)  
H: 4.35" (110mm)  
D: 1.35" (34mm)

**HOW TO DESIGN AND SPECIFY**

- A single occupancy sensor can communicate to all control devices in the room
- Use in small rooms or areas with medium to high partitions
- For 8 ft ceilings: 484 ft<sup>2</sup>
- For 12 ft ceilings: 676 ft<sup>2</sup>

**PRODUCT OPTIONS**

**Wall-mount sensors**

Use in large open rooms with few tall obstructions.  
Coverage: 3,000 ft<sup>2</sup>

- LRF2-OWLB-P-WH : Occupancy / Vacancy
- LRF2-VWLB-P-WH : Vacancy only

**Corner-mount sensors**

Use in medium to large open rooms with few tall obstructions.  
Coverage: 2,500 ft<sup>2</sup>

- LRF2-OKLB-P-WH : Occupancy/vacancy
- LRF2-VKLB-P-WH : Vacancy only

**Hallway sensors**

For a 6 ft wide hallway: 50 ft coverage  
For a 10 ft wide hallway: 150 ft coverage

- LRF2-OHLB-P-WH : Occupancy/vacancy
- LRF2-VHLB-P-WH : Vacancy only

**Accessories**

- LRF-ARM-WH : Flexible armature mounting kit for Radio Powr Savr wall, hall, corner sensors
- L-WIRECAGE-C : Wire guard for ceiling-mount sensor
- L-WIRECAGE-W : Wire guard for in-wall sensor

**Hallway sensor maximum recommended length chart (sensor centered within hallway)**

Width of hallway	Length of hallway
6ft (1.6m) or less	50ft (15.2m)
8ft (2.4m)	100ft (30.5m)
10ft (3.0m) or more	150ft (45.7m)

\* Sensor mounting shown at 7 ft (2.1 m). Mounting height should be between 6 and 8 ft (1.6 and 2.4 m).

\*\* 12 ft (3.7 m) is the maximum mounting height allowed.

**Sensor coverage diagram**

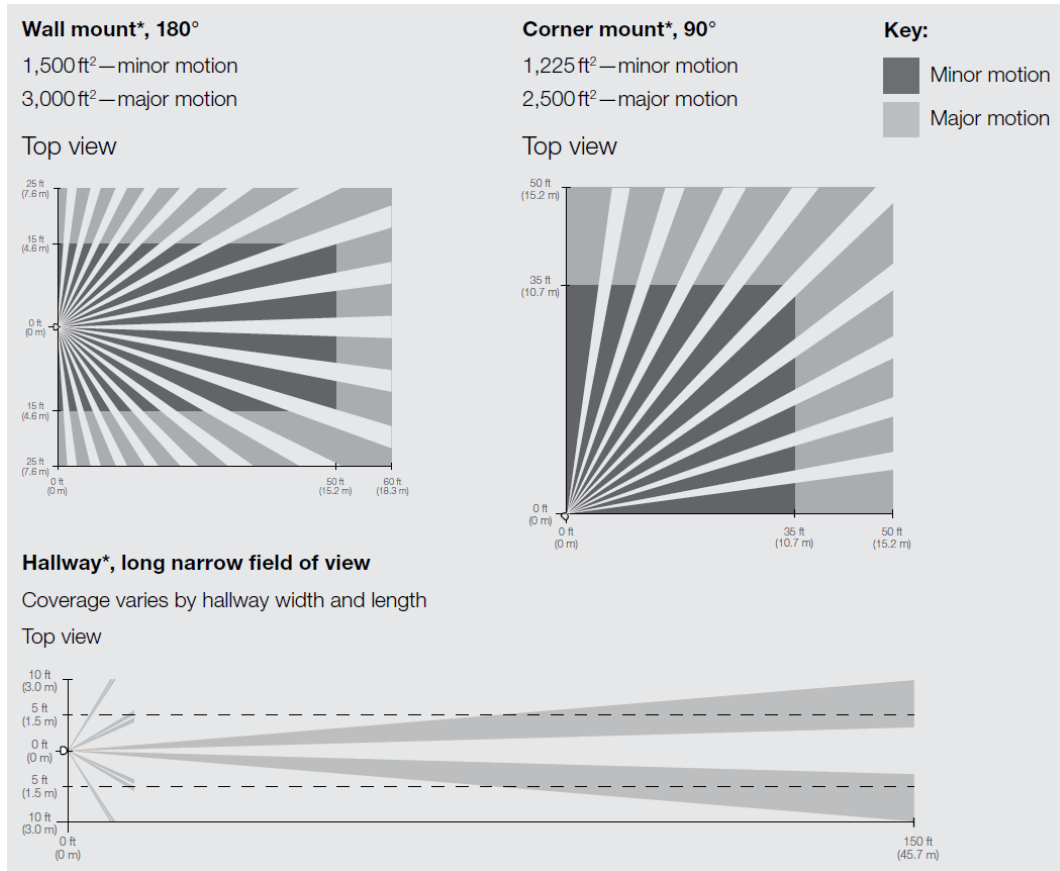



## Sensors: Ceiling Daylight sensor (Supplied by Lutron distributor)



### Wireless daylight sensor

#### Dimensions

W: 1.6" (41mm)

H: 1.6" (41mm)

D: 0.7" (17mm)

### HOW TO DESIGN AND SPECIFY

#### A single daylight sensor is capable of controlling:

- All Maestro switching and dimming zones
- All PowPak switching zones
- All PowPak dimming modules with 0-10 V control

### PRODUCT OPTIONS

#### Daylight sensors

- LRF2-DCRB-WH : Daylight sensor

\* Sensor mounting shown at 7 ft (2.1 m). Mounting height should be between 6 and 8 ft (1.6 and 2.4 m).

\*\* 12 ft (3.7 m) is the maximum mounting height allowed.

### Sensor coverage diagram

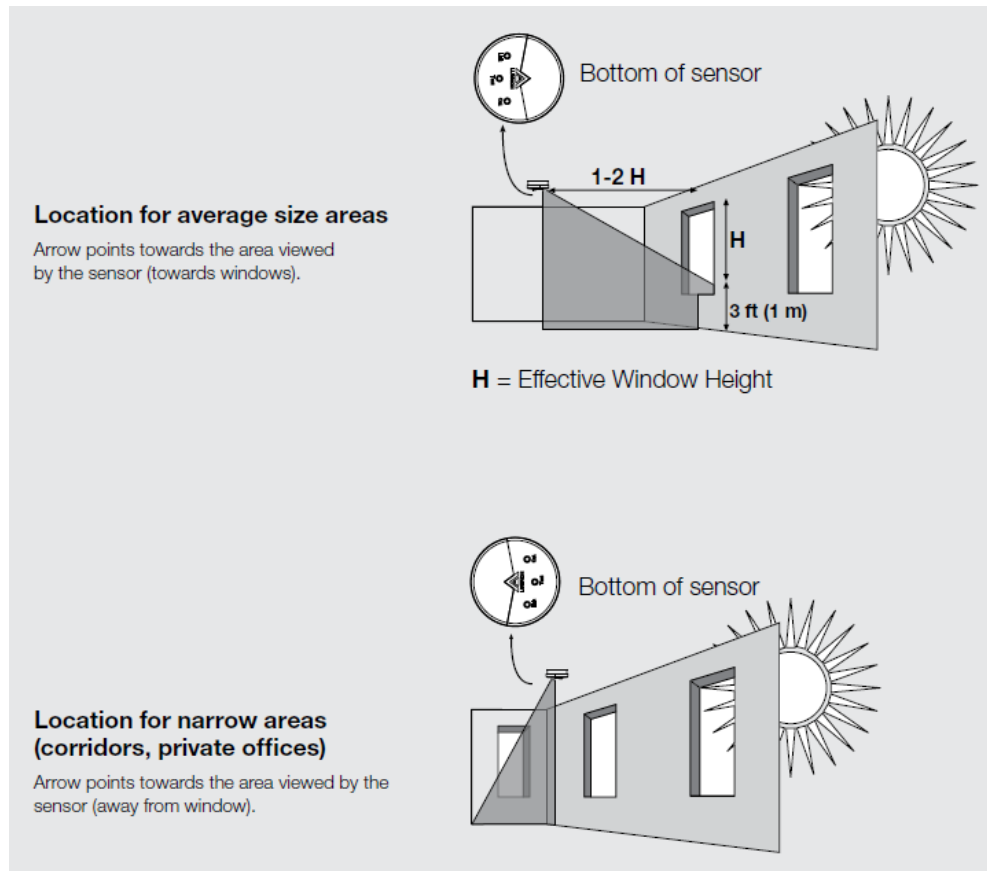

## Load Controllers: In-wall Switches & Dimmers (Supplied by Lutron distributor)



### Mestro Wireless Switches

Dimensions  
W: 2.94" (75mm)  
H: 4.69" (119mm)  
D: 1.44" (38mm)

#### HOW TO DESIGN AND SPECIFY

- Select one switch per lighting zone.
- Select appropriate model based on the size of the connected load.  
6 A: 600 W lighting @ 120 V  
8 A: 960 W lighting @ 120 V or 2216 W @ 277 V
- If existing switch does not have a neutral, choose the model available for 120/277 V with no neutral required.
- Select from up to 27 colors to complement the décor\*.
- Add an additional Pico remote for rooms with multiple switches for a single zone.

#### PRODUCT OPTIONS

##### Dual Voltage No Neutral switches

- MRF2S-8S-DV-XX : 8A lighting, 1/10HP fan @ 120V only, 120-277V, no neutral

##### 120 V Neutral required switches

- MRF2S-6ANS-XX : 6A lighting, 1/10HP fan, 120V only
- MRF2-8ANS-120-XX : 8A lighting, 1/4HP fan, 120V only



### Mestro Wireless dimmers

Dimensions  
W: 2.94" (75mm)  
H: 4.69" (119mm)  
D: 1.44" (38mm)

#### HOW TO DESIGN AND SPECIFY

- Select one wireless dimmer per lighting zone.
- Select appropriate model based on the size and type of existing load.
- Most models do not require a neutral.
- Select from up to 27 colors to complement the décor\*.
- Add an accessory dimmer or a Pico wireless remote for rooms with multiple switches for a single zone

#### PRODUCT OPTIONS

##### Maestro Wireless dimmers

- MRF2S-6CL-XX : 150W dimmable CFL/LED, 600 W incandescent/halogen, 600VA MLV, 120V, no neutral
- MRF2S-6ELV-XX : 600W ELV, 120V
- MRF2S-6ND-120-XX : 600W/VA incandescent/halogen/ MLV, 120V
- MA-R-XX : Accessory dimmer for multi-location lighting controls, 120V

\*(XX in the model number represents color/finish code; use WH for White; please visit [www.lutron.com](http://www.lutron.com) for other color choices.)

## Remotes: Pico wireless remotes (Supplied by Lutron distributor)



### Pico wireless remotes (3-button nightlight with raise/lower)

Dimensions  
W: 1.28" (33mm)  
H: 2.60" (66mm)  
D: 0.33" (8mm)

#### HOW TO DESIGN AND SPECIFY

- Select one 2-button Pico wireless remote to add a location with ON/OFF control
- Select one 3-button Pico wireless remote to add a location with ON/OFF control and one preset
- Select one 2-button with raise/lower Pico wireless remote to add a location with ON/OFF and BRIGHTEN/DIM control
- Select one 3-button with raise/lower Pico wireless remote to add a location with ON/OFF, BRIGHTEN/DIM control and one preset
- Select whether a nightlight is needed (2-button and 3-button with raise/lower only)
- \* Note: Spaces with a PowPak relay or dimming module will not have a local control in the room unless a Pico is added

#### PRODUCT OPTIONS

##### 2-button remotes

- PJ2-2BRL-GXX-L01 : 2-button with raise/lower wireless remote
- PJ2-2B-GXX-L01 : 2-button with raise/lower wireless remote
- PJN-2B-GXX-L01 : Nightlight 2-button wireless remote

##### 3-button remotes

- PJ2-3BRL-GXX-L01 : 3- button with raise/lower wireless remote
- PJ2-3B-GXX-L01 : 3-button wireless remote
- PJN-3BRL-GXX-L01 : Nightlight 3-button with raise/lower wireless remote

\*(XX in the model number represents color/finish code)

**HOW IT WORKS**

- No wires—put it where it's most accessible.
- Pedestal mount for tabletop use.
- Surface mount anywhere with Claro wallplate.
- 10-year battery life.

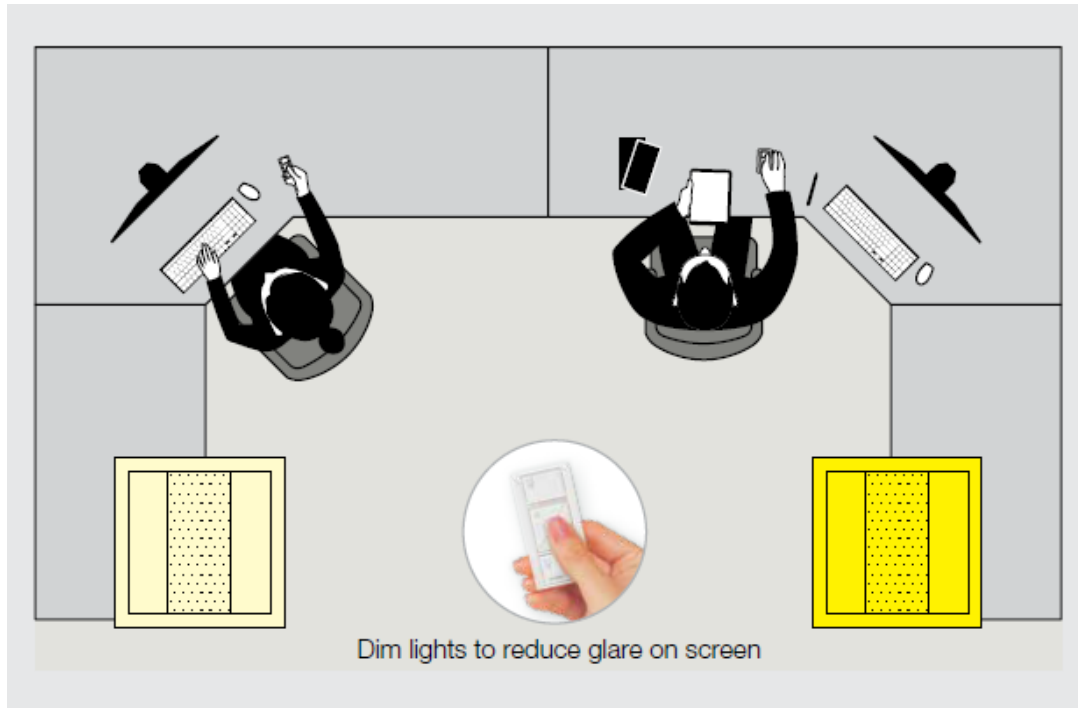

Pico wall mounted (in a wallplate) - Add a new point of control anywhere with absolutely no wires



Raise lights for reading visibility

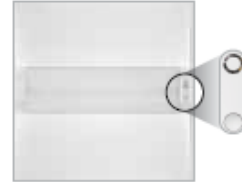

Individual fixture control

**WARRANTY**

Vive wireless solutions are all covered by a one-year parts warranty. Additional warranty and technology support options are available to meet your project needs. See options below.

Support Options	Limited Warranty	Silver	Gold	Platinum
Maximum coverage duration	2 Years	1-10 Years	1-10 Years	1-10 Years
100% Replacement Parts	●	●	●	●
Diagnostic Labor— First Available Response	●	●		
Diagnostic Labor— 72-Hour Response			●	
Diagnostic Labor — 24-Hour Response				●
Annual Preventive Maintenance Visit			●	●