

# SXTE

Project Name:	
Type:	



**APPLICATION**

The steel housing exit signs offer a sleek appearance in a rugged design.

**FEATURES:**

- Durable, powder coated 20-gauge steel construction. Premium-grade with white painted heavy duty steel housing with KO's provided for mounting.
- Letters 6" height with 3/4" stroke.
- Steel knockout chevron directional indicators.
- Single or double face configuration.
- 90+ minute emergency operation.
- Available in white or black housing.

**MOUNTING:**

- Mounting canopy included for top or end mount.
- Universal knockout pattern on back plate for wall mount.

**ELECTRICAL:**

- 120/277V dual voltage operation standard.
- Charge rate and power "ON" LED indicator light and push-to-test switch for mandated code compliance testing.

**LAMPS:**

- LED lamps are operating in normal (AC input) and emergency (DC input) modes.
- Ultra-bright, energy efficient, long-life Red or Green LED.

**BATTERY:**

- Maintenance-free and rechargeable Ni-Cad battery on emergency (EM) units.
- Fully automatic solid-state, two-rate charger initiates battery charging to recharge a discharged battery in 24 hours.
- Internal solid-state transfer switch automatically connects the internal battery to LEDs for minimum 90 minute emergency illumination.

**LISTING:**

- 5 years limited warranty on materials and all electronics. Battery pro rated for five years.
- UL listed for damp locations & meets UL924, National Electrical Code, NFPA 70 and the Life Safety Code, NFPA 101.
- ARRA compliant (optional).

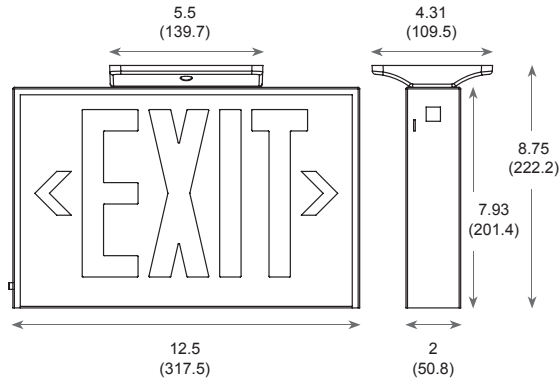

All dimensions are in inches (millimeters).

**ORDERING INFORMATION**

**EXAMPLE: SXTE-1-R-W-EM**

MODEL	# OF FACE	LETTER	HOUSING COLOR	OPERATION	OPTIONS
SXTE	1 Single 2 Double	R Red G Green	W White Housing B Black Housing	(Blank) EM AC-only Battery Back up	<b>WG-1</b> Steel Wire Guard (13.5" x 15" x 6") <b>PCS-1</b> Polycarbonate Guard (3.25" x 9" x 2.75") <b>BG-1</b> Polycarbonate Vandal Shield Guard (15" x 22" x 8") <b>SDT</b> Self Diagnostics <b>ARRA</b> Assembled in USA for Buy American Act