



UNDERSTANDING COPYRIGHT LAW

Jordan Greenberger, Esq.

J. Greenberger, PLLC

www.brooklyncopyrightlawyer.com

(718) 502-9555

November 3, 2016

Jordan Greenberger, Esq.

J. Greenberger, PLLC

- Intellectual Property (IP) lawyer
 - *Copyright*
 - *Trademark*
 - *Litigation*
 - *Transactions*
- Copyright Law “101” – Treatises!
- Questions? Please ask
- Why Are You Here?





Why Do I Care?

■ Valuable Asset

– *Traditional: Arts & Media*

– *“Emerging”: Technology/Start-ups, Fashion*

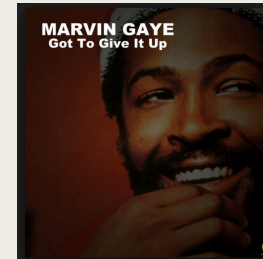

Why Do I Care (continued...)

■ Potential Liabilities

- *Technological advances* [copy>paste]
- *Strict Liability* [innocent / willful / fair use]

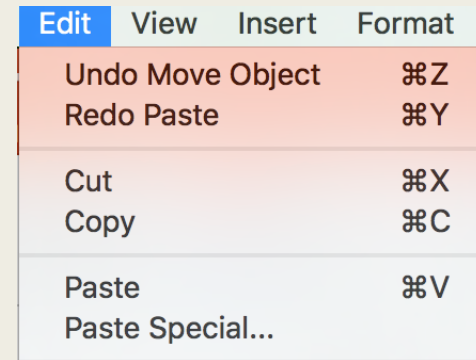

Edit	View	Insert	Format
Undo Move Object			⌘Z
Redo Paste			⌘Y
Cut			⌘X
Copy			⌘C
Paste			⌘V
Paste Special...			

Five Things To Know About Copyright

1. What Is Copyright & What Does It Protect
2. How & When Copyright Protects
3. Who Has A Copyright Interest
4. Using Copyrighted Work
5. Resolving Copyright Disputes



What Copyright Is Not

- Other Types Of Intellectual Property

- Patent (inventions)
- Trademark (source of goods/services)
- Trade Secrets
- Related: Right of Publicity, Defamation, Unfair Competition

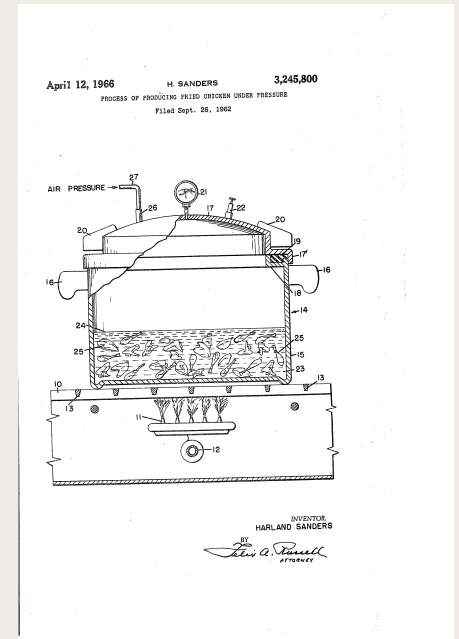

- Overlap?



What Copyright Protects

- Original Works Of Authorship
 - *Common: books, songs, plays, pictures, films*
 - *Less-Obvious: compilations, computer code, tattoos, grafitti*
- “Original” – A Low Threshold (e.g., fabric designs, simple photographs)
- Utilitarian items / Separate Design Elements (e.g., lighting fixtures, furniture, cheerleader uniforms?)
- Idea vs. Expression

How Copyright Protects

- Exclusive Rights (Section 106)
 - *Reproduce*
 - *Prepare a derivative work*
 - *Distribute copies*
 - *Perform or display the work publicly*

- Duration
 - *Life +70*
 - *Anonymous, Work Made For Hire:
Publication + 95 / Creation + 120*



Do I Need To Register?

- When Does Author Acquire Rights?
- Fixation in any tangible medium of expression that is perceptible either directly or with the aid of a machine or device
 - *Pen to paper*
 - *Image to film*
 - *Sound to tape*



Benefits Of Registration

- Public Record
- Certificate of Registration
- Litigation
 - *Evidence of validity of copyright and ownership*
 - *Enhanced remedies (attorney's fees & statutory damages)*
- Compelling reason not to register? (Privacy, cost)



Who Has A Copyright Interest

- Author(s)
- Work Made For Hire – Issues of Control
 - *Employee within scope of employment*
 - *Specially ordered/commissions + signed writing*
- Contributor?

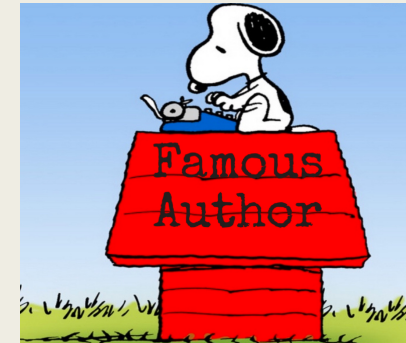

Who Has A Copyright Interest (cont.)

- Voluntary Transfers – Sales, Licenses, Collateral, Bequeathed By Will

- *Bundle of rights - in whole or in part*
- *Licenses: Exclusive or non-exclusive*
- *Termination of transfers / reversions*



- Material Object On/In Which Work Is Embodied (& First-Sale Doctrine)



Using Another's Copyrighted Work

- Public Domain vs. Public Sphere
- Licensing
- Copy & paste with “credit”?
- Political speech/elections?



Using Another's Copyrighted Work (cont.)

■ Fair Use

- *Case by case analysis*
- *Criticism, comments, news reporting, teaching*
- *Purpose & character (commercial in nature), amount and substantiality of the portion used, effect upon the potential market for or value of the work*
- *Whether the new work uses the copyrighted material itself for a purpose, or imbues it with a character, different from that for which it was created.*

■ De minimis (insubstantial and trifle – unable to identify the source) ([Madonna](#) 0:56)



Resolving Copyright Disputes

- Privately
 - *DMCA "Take Down"*
 - *Cease & Desist (C&D) Letters*
 - *Negotiation*



Resolving Disputes (cont.)



- Federal Court – Infringement Claims & Declaratory Judgment Actions
 - *Monetary Damages – Actual vs. Statutory; Attorney’s Fees*
 - *Injunctions & Impoundment*
- Standing Issue
- Secondary liability
- Breach of contract vs. copyright infringement
- Small Claims Court (?)

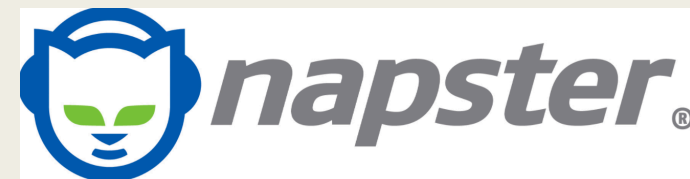

Complex & Nuanced

- General overview
- Competent counsel
- Questions?



Jordan Greenberger, Esq.

(718) 502-9555

jordan@jgreenbergerlaw.com

Disclaimer. Viewing this PowerPoint or contacting J. Greenberger, PLLC does not create an attorney-client relationship. This PowerPoint is intended as a general comment on certain areas in the law. It does not contain a complete legal analysis or constitute an opinion of J. Greenberger, PLLC, or any member of the firm on the legal issues herein described. This PowerPoint contains timely information that may eventually be modified or rendered incorrect by future legislative or judicial developments. It is recommended that readers not rely on this general guide in structuring or analyzing individual transactions or matters but that professional advice be sought in connection with any such transaction or matter.

Attorney Advertising. It is possible that under the laws, rules or regulations of certain jurisdictions, this may be construed as an advertisement or solicitation.

All Rights Reserved.