

AEF-nr.	Fabrikant	Model	Nederland BV audatex 31.05.89 © Copyright AUDATEX 1993				Eigenaar			
709	Alfa Romeo	75 09/85-					Kenteken			
						Expert				
Type	Code X	Uitvoeringsspecificatie Code X	Uitvoeringsspecificatie Code X	Uitvoeringsspecificatie Code X	Uitvoeringsspecificatie Code X	Tarieven				
STANDAARD INVOERGEGEVENS		OPTIONELE INVOERGEGEVENS		▼		Arbeidstarief per AE	Spuittarief per AE		Excl. materiaal Incl. materiaal	
75 1,6 (161.000)	709 01	schuifdak elektrisch	C 2	stuurbechrachting	Q 1					
75 1,6 IE (161.840)	709 12	▼		antiblokkeersysteem	Q 7					
75 1,8 (161.02/161.020/161.021/161.022)	709 02	mistlampen	I 2	▼ velgen						
75 1,8 IE (161.682/161.800)	709 13	koplampreinigingsinstallatie	I 6	5 1/2 J x 13	S 1					
75 1,8 Turbo (161.34/161.340)	709 03	buitenspiegel r. elektrisch verst.	G 7	5 1/2 J x 14	S 2					
75 1,8 Turbo America (161.34/161.340)	709 04	glas blauw getint	F 4	6 J x 14	S 3					
		glas brons getint	F 5	5 1/2 J x 13 lichtmetaal	S 4					
				5 1/2 J x 14 lichtmetaal	S 5					
75 2,0 (161.08/161.080)	709 05	▼ ZENDER carrosseriedelen		6 J x 14 lichtmetaal	S 6					
75 2,0 Twin Spark (161.220/161.222)	709 06	spoiler bumper voor	W 1	6 1/2 J x 14 lichtmetaal	S 7					
		dorpellijsten	X 7	6 J x 15 lichtmetaal	S 8					
75 2,0 Twin Spark S (161.220/161.222)	709 07	spoiler onder achterbumper	X 1	▼ banden						
		a.-spoiler	W 6	185/70 TR 13	R 1					
				185/70 HR 13	R 2					
75 2,0 Turbo Diesel (161.040)	709 11	airconditioning	F 1	185/65 HR 14	R 3					
		ruitbediening achter elektrisch	G 4	195/60 VR 14	R 4					
75 3,0 V6 (161.200)	709 17	stoelbekleding leer	J 4	195/55 VR 15	R 5					
75 3,0 V6 America (161.202/161.322)	709 10	▼								
75 3,0 V6 Quadrifoglio (161.502)	709 15	combi-instrument BORLETTI/VEGLIA	L 4							
		combi-instrument JAEGER	L 5							
		▼ katalysator								
		katalysator geregeld	V 1							
		katalysator niet geregeld	V 2							
Uitvoeringsspecificatie Code X										
▼ bouwjaren										
v.a. 01/88	D 1									
v.a. 09/88	D 2									
v.a. 10/89	D 3									
v.a. 03/90	D 4									
v.a. 07/90	D 5									
▼ wisselbak										
5-versnellingen	P 3									
▼ lak										
kunsthars (uni)										
2-K-acryl (uni) rep.-lak	Y 2									
2-lagen (uni) rep.-lak	Z 8									
2-lagen-metallic	Y 4									
▼ spuitmethode										
spuiten deel in uitgeb. toestand	Y 8									
voorsp. uitgeb. afsp. gemonteerd	Y 7									
Fantoom		Uitvoeringsspecificaties				Speciaal rapport				
Merk						Resultatenblad	1			
						Controleblad	1	2		
Model						Oude prijs	A			
						Prijdatum				
Type						Tekst kort	1	Lang	2	
						Geen spuitw.	L			
						R Risico				
						↳ aant. - X -		+ aant. - X - zones		= Totaal aant. - X -
						* Voor codes zie "Audatex-codekaart"				
						** Alleen te gebruiken bij vervanging carrosserie				
						*** Naar keuze invullen V,GV,B,H,GH,C,SV,SH,S of O				
						Serie: 2/2		Wijzigingsdatum 23.12.93		(100893)
						Alfa Romeo		75		709

aanst.-X.

10

4931
4935
4955
4919
4920
4921
4917
4918
4956
4959
4933
4934
4957

V V V V V V V V V V V V VB VB VB VB VB VB VB

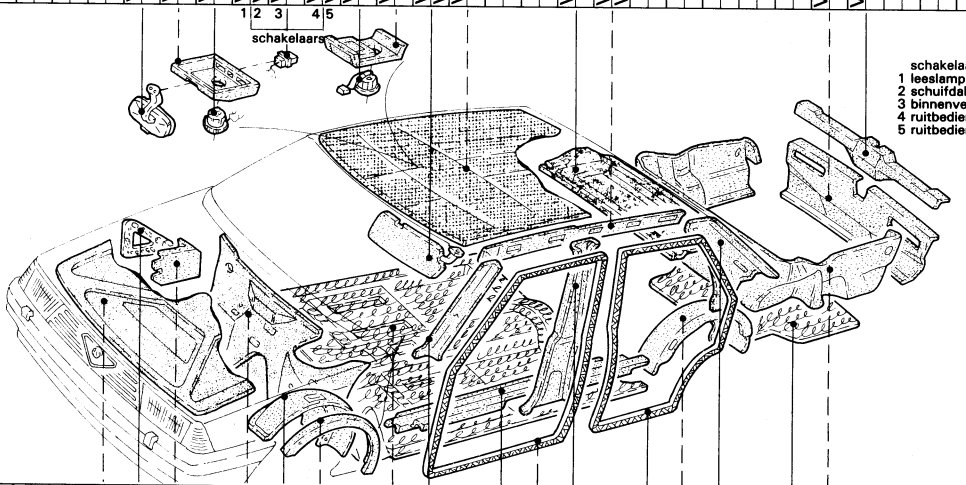

- schakelaars:
1 leestamp
2 schuifdak
3 binnenverlichting
4 ritbediening l.
5 ritbediening r.

10

0481 4936 4939 1322 0841 0842 0839 0840 4873 4941 4942 2193 2194 1509 1510 4947 4948 1809 1810 4991 4992 4971 4972 4978 4981

VB V V V VB VB VB VB VB VB VB VB VB VB VB VB V VB

aanst.-X.

11

4411 4415 4413 4428 4444 4431 4414 4437 4438 4419 4423 4332 4366 4371 4384 4379 4355 4359 4386 4390 4427 4349

VB V V V V V V V V V V V V VB V V V V V V V V

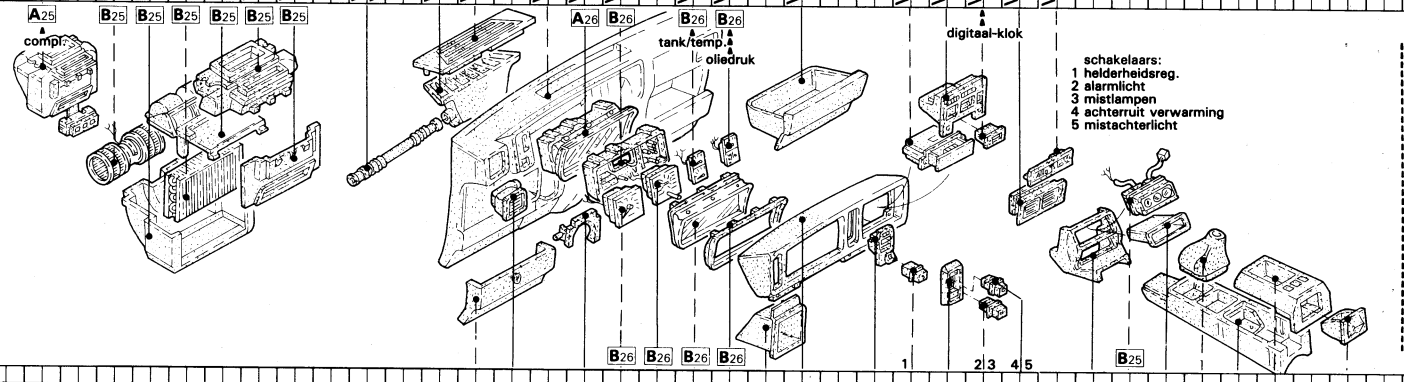

- schakelaars:
1 helderheidsreg.
2 alarmlicht
3 mistlampen
4 achterruiet verwarming
5 mistachterlicht

Combi-Instrument
Borletti

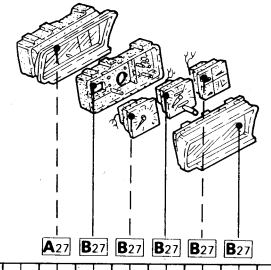

A27 B27 B27 B27 B27 B27

11

4339 4417 4418 4342 4397 4375 4368 4369 4345 4343 4441 4442 4443 4445 4446 4447 4448 4449 4450 4407 4432 4409 8993 4400 4402 4404

V VB V V V V V

4366 4371 4397 4375 4381 4368

V V V V V V

aanst.-X.

12

V	4660
B	4661
B	4662
V/B	4495
V	4496
V	4567
V	4568
V	4589
V	4590
V	4597
V	4598
V	4603
V	4604

set
 A20 B20 B20 B20 C20 B21 B21 A21

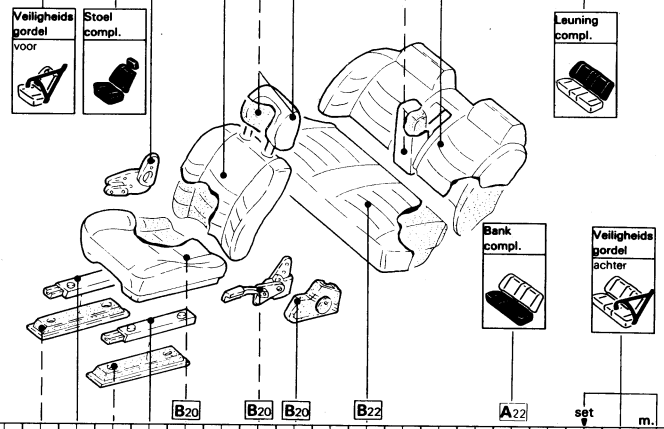

12

V	4563
V	4564
H	4549
H	4550
V	4547
V	4548
V	4543
V	4544
V	4535
V	4536
V	4565
V	4566
V	4561
V	4562
V	4679
V/B	4663
V	4843
B	4841
B	4842
B	4840

set
 B20 B20 B20 B22 A22

13

13

aant.-X

aant.-X

aant.-X

aant.-X

Wisselbak
US = P3



8851	9007	9005	8995	8994	8997	8875	8973	8965	8979	8913	8914	8884	8872	8863
------	------	------	------	------	------	------	------	------	------	------	------	------	------	------

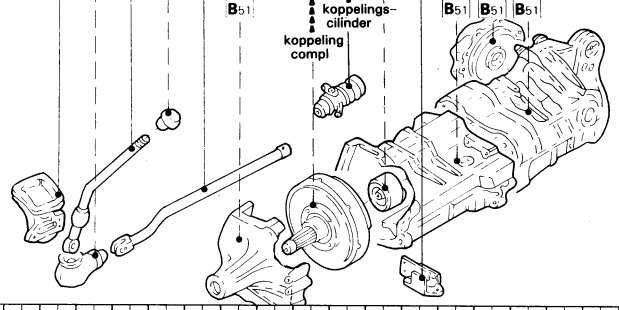

aant.-X.

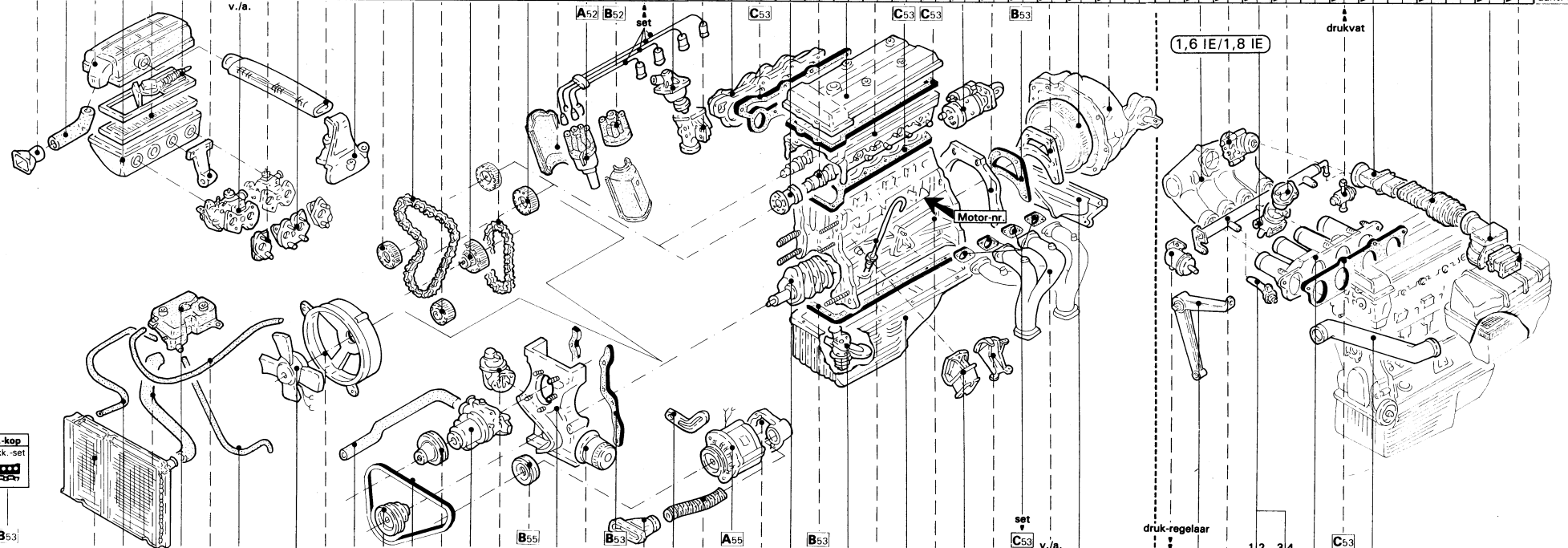

8388	8389	8401	8402	8395	8396	8397	8193	8194	8201	8202	8200	8374	8804	80322	80272	82662	82552	80292	83102	83112	8463	8464	8451	8457	8467	7880	7879	8221	8241	83052	83062	83012	83022	79412	83312	83512	79612	8501	81012	81032	81052	89702	8966	8222	8149	7879	7880	8168	8144	8138	8142	8143
------	------	------	------	------	------	------	------	------	------	------	------	------	------	-------	-------	-------	-------	-------	-------	-------	------	------	------	------	------	------	------	------	------	-------	-------	-------	-------	-------	-------	-------	-------	------	-------	-------	-------	-------	------	------	------	------	------	------	------	------	------	------

aant.-X.

79312	79002	79012	83502	VBCH7761	7788	7776	7787	7789	7784	7790	7767	7773	82732	7855	78312	78132	80912	8417	79223	8041	79232	79242	8439	8428	8437	8411	8431	82632	80752	8051	80682	80652	79202	8631	8632	8621	8622	8807	8802	8803	8964	8166	8397	8173	8601	8602	8603	8604	8221	8241	8389
-------	-------	-------	-------	----------	------	------	------	------	------	------	------	------	-------	------	-------	-------	-------	------	-------	------	-------	-------	------	------	------	------	------	-------	-------	------	-------	-------	-------	------	------	------	------	------	------	------	------	------	------	------	------	------	------	------	------	------	------

aant.-X.

18	8388	8389	8393	V B C H 7779	7781	7782	8138	8740	8755	8756	8720	8725	8724	8723	8805	8802	82412	82212	8803	7875	7876	8047	7874	83332	83342	83352	83354	83356	83352	83362	8509	8511	81052	8148	8147	
	V	V	V	V	V	V	V	V	V	V	V	V	V	V	V	V	V	V	V	V	V	V	V	V	V	V	V	V	V	V	V	V	V	V	V	V

2,0 Turbo Diesel

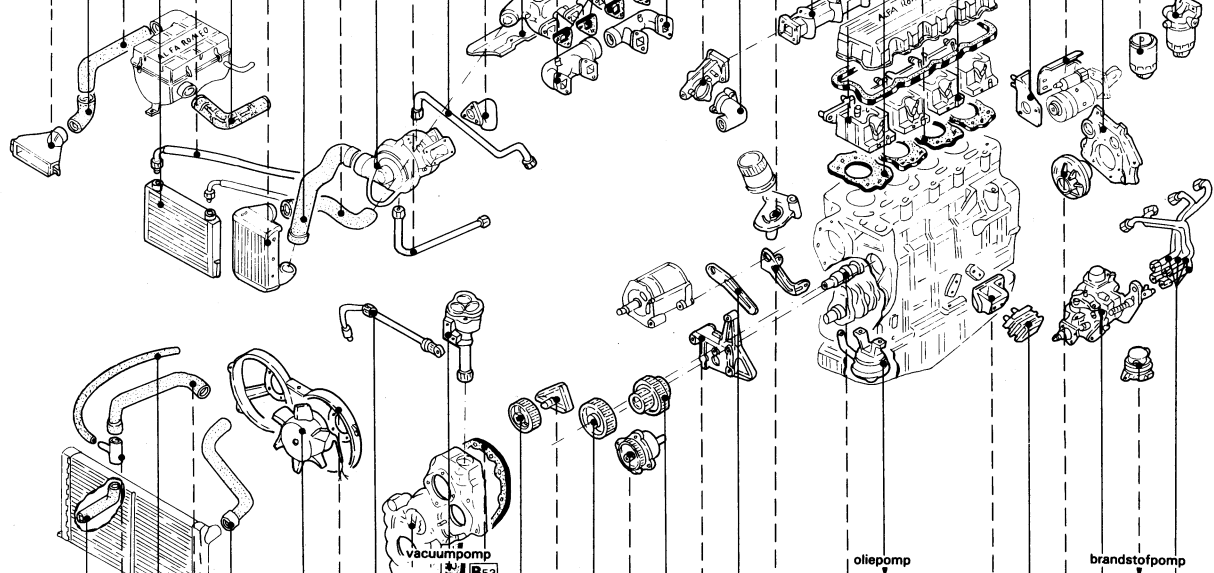

18	7773	7774	7775	7777	7776	7790	7791	7767	8589	79222	85872	79232	8289	82902	83112	82872	82882	8425	8428	8426	83012	80512	8621	8622	8631	8632	82702	85692	8091	85812						
	V	V	V	V	V	V	V	V	V	V	V	V	V	V	V	V	V	V	V	V	V	V	V	V	V	V	V	V	V	V	V	V	V	V	V	V

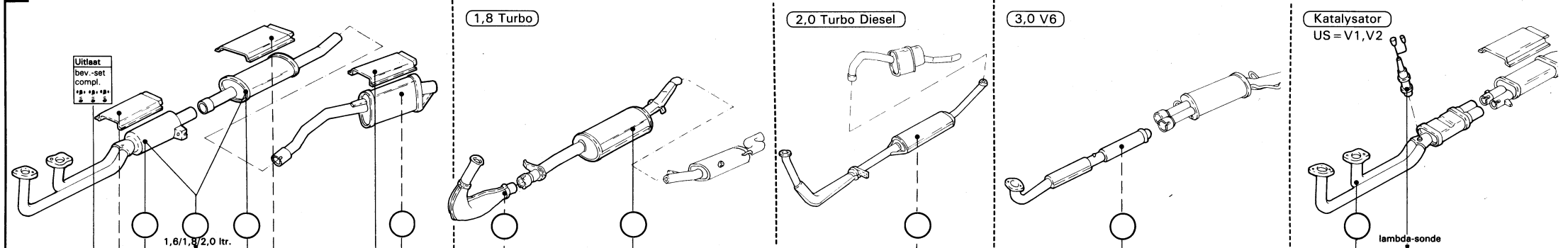

19	8840	H8841	H8815	H8815	H8823	H8842																														
	V	V	V	V	V	V																														

Gebruikersnummer _____ ● _____ Volg-nr. _____
 Rapportnummer _____
 Bezichtigingsdatum _____

Nederland BV
audatex 31.05.89
 © Copyright AUDATEX 1993

AUDATEX Nederlands BV
 Handelsweg 6
 Postbus 124
 3700 AC Zeist

TEL: 03404/35800
 FAX: 03404/15859

Algemene gegevens

Opmerkingen

Werkzaamheid _____
 Polisnummer _____
 Schadenummer _____
 Schadedatum _____
 Oprachtdatum _____

Expertise-adres _____ (V/T/R/C)
 Eigenaar _____ (V/T)
 (V = VERZEKERDE / T = TEGENPARTIJ / R = REPARATEUR / C = CONTACTPERSOON)

Verzekerde
 Naam _____
 Straat/Nr. _____
 PC/Plaats _____
 Tel.nr./Land _____ N.L.
 Vrije tekst _____

Tegenpartij
 Naam _____
 Straat _____
 PC/Plaats _____
 Tel.nr./Land _____ N.L.
 Vrije tekst _____

Objectgegevens
 Object _____
 Merk _____
 Model/Type _____
 Kenteken/Land _____ N.L.
 Chassisnummer _____
 Cat.waarde _____ (incl. BTW)

Kleur _____
 Soort brandst. _____
 Afgifte deel 1 _____
 Afgifte deel 2 _____
 Bouwjaar 1,9 _____
 Toestand voert. _____ (1 = Goed 2 = Redelijk 3 = Matig 4 = Slecht 5 = zie opm.)
 Km stand _____

Schadegegevens
 Schade bev.zich. _____
 Stootrichting _____ (00-12)
 Aangrijppunt _____ (A t/m K)
 Schade oorzaak _____ (A/B/D/H/S/V/W/O)
 Eerdere schade _____ (-/J/N)
 Reparatieduur _____ dagen
 Gezien door expert _____ (J/N)

Polis-/Betaalgegevens
 Verzek. bedrag _____
 Dekking/Branche _____ 2,0
 BTW-verrekenb. _____ (-/J/N)
 Betaalgar./ber. _____ (-/J/N)
 Akte van cessie _____ (-/J/N)

Aangrijppunt/Stootrichting

Overige gegevens
 Opdrachtgever _____
 Correspondent _____
 Telefoonnr. _____
 Tussenpersoon _____
 Erkenningsnr. _____

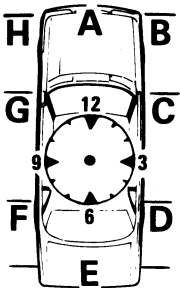

I boven zijde J onder zijde K totaal verlies

Reparateur/Contactpersoon
 Naam _____
 Straat _____
 Nr./Toevoeging _____
 PC/Plaats _____
 Tel.nr./Land _____ N.L.

Akkoord *

Expert
 Handtekening/
 Stempel

Reparateur
 Handtekening/
 Stempel

audatex AEF-nr. 709

* betreft akkoord voor de vastlegging van de schade op dit formulier