

Type	Code X	Uitvoeringsspecificatie Code X	Uitvoeringsspecificatie Code X	Uitvoeringsspecificatie Code X	Uitvoeringsspecificatie Code X
<b>STANDAARD INVOERGEGEVENS</b>					
Bestelwagen	10	<b>872 01</b>	▼ portieren		
Bestelwagen	14	<b>872 02</b>	1 laaddeur rechts	<b>K 6</b>	
Bestelwagen 4x4	14	<b>872 14</b>	2 laaddeuren rechts	<b>M 1</b>	glas getint <b>F 4</b>
Bestelwagen big volume	14	<b>872 03</b>	schuifdeur links	<b>M 5</b>	bestelwagen met ruiten <b>K 4</b>
Bestelwagen big volume 4x4	14	<b>872 15</b>	schuifdeur rechts	<b>M 6</b>	achterdeur met ruit <b>K 7</b>
Bestelwagen big volume	14	<b>872 04</b>	achterklep	<b>K 5</b>	▼
Laaddeur zijkant	14	<b>872 04</b>	▼ carburateurmotor		comfort uitvoering <b>L 4</b>
Bestelwagen big volume Maxi		<b>872 11</b>	1971 ccm (2,0 ltr.) 55kW	<b>N 2</b>	buitenspiegelarm verlengd <b>G 5</b>
Combi 5/6-persoonen		<b>872 05</b>	1971 ccm (2,0 ltr.) kat. 63kW	<b>N 6</b>	buitenspiegel l. elektr. verst. <b>G 6</b>
Combi 8/9-persoonen		<b>872 06</b>			buitenspiegel r. elektr. verst. <b>G 7</b>
Bus 8/9-persoonen		<b>872 07</b>	▼ diesel		achterrutewisser <b>I 8</b>
Bus 8/9 personen 4x4		<b>872 16</b>	1929 ccm (1,9 ltr.) 52kW	<b>N 4</b>	▼
Luxusbus panorama		<b>872 08</b>	2499 ccm (2,5 ltr.) 55kW	<b>N 3</b>	koplampen duplo <b>I 2</b>
Minibus		<b>872 26</b>			koplampreinigingsinst. <b>I 6</b>
Pick-up	14	<b>872 09</b>	▼ turbo-diesel		koplamphoogteregeling <b>I 7</b>
Pick-up 4x4	14	<b>872 17</b>	1929 ccm (1,9 ltr.) 60kW	<b>N 7</b>	▼
Pick-up Maxi		<b>872 12</b>	2499 ccm (2,5 ltr.) 68/70kW	<b>N 5</b>	stoelbekleding stof <b>J 1</b>
Pick-up dubbele cabine	14	<b>872 10</b>			stoelbekleding kunstleer <b>J 2</b>
Pick-up dubbele cabine Maxi		<b>872 13</b>	katalysator geregeld	<b>V 1</b>	passagiersstoel <b>L 2</b>
			oxidatiekatalysator (diesel)	<b>V 4</b>	passagiersbank <b>L 3</b>
Chassis met cabine	10	<b>872 19</b>	▼ wisselbak		stoelen v. in hoogte verst. <b>L 5</b>
Chassis met cabine	14	<b>872 20</b>	5-versnellingen	<b>P 3</b>	▼
Chassis met cabine Maxi		<b>872 21</b>			scheidingswand cabine <b>K 3</b>
Chassis met cabine 4x4	14	<b>872 18</b>	▼ wielbasis		airconditioning <b>F 1</b>
Chassis met dubbele cabine	14	<b>872 22</b>	2923 mm	<b>K 1</b>	verwarming extra v. <b>F 7</b>
Chassis met dubbele cabine Maxi		<b>872 23</b>	2929 mm	<b>K 9</b>	verwarming extra a. <b>I 5</b>
Chassis met cabine en vlakke bodem	14	<b>872 24</b>	3200 mm	<b>K 8</b>	▼
Chassis met cabine en vlakke bodem	18	<b>872 25</b>	3653 mm	<b>K 2</b>	stuurbekrachtiging <b>Q 1</b>
Chassis met dubbele cabine en vlakke bodem	14	<b>872 31</b>	▼ lak		brandstofvulpijp kunststof <b>M 9</b>
			2-K-acryl (uni) rep.-lak	<b>Y 2</b>	▼ banden
			2-lagen-metallic	<b>Y 4</b>	165 R 14 C8PR <b>R 1</b>
			▼ spuitmethode		185 R 14 C8PR <b>R 2</b>
			spuiten deel in uitgeb. toestand <input type="checkbox"/>	<b>Y 8</b>	185 R 14 reinforce <b>R 4</b>
			voersp. uitgeb. afsp. gemonteerd <input type="checkbox"/>	<b>Y 7</b>	195/75 R 16 <b>R 3</b>
			v.a. mei '91	<b>D 1</b>	
			v.a. juli '91	<b>D 2</b>	
			v.a. november '91	<b>D 3</b>	
			v.a. maart '92	<b>D 4</b>	
			v.a. mei '92	<b>D 5</b>	
			v.a. november '92	<b>D 6</b>	
			v.a. februari '93	<b>D 7</b>	

Tarieven			
Code	Bedrag	Excl. materiaal	Incl. materiaal
<b>Tekstzone codes</b>			
<b>Onderdelen*</b>			
<b>Arbeidsloon*</b>			
<b>Spuitloon*</b>			
<b>Spuitmateriaal</b>	45	fl/dm <sup>2</sup>	51
<b>Anti - roest</b>	70 fl	Kleinmateriaal	27 fl
<b>behandeling</b>	71 fl	**	Aftrek 1 <sup>e</sup> schade 95 fl
<b>Uitlijnen</b>	74 fl		Begr. kosten rep. 90 fl
<b>Hulpstoffen</b>	63 fl		Poetsen/reinigen 67 fl
<b>Bewerking</b>			
		<b>Benaming</b>	<b>Bedrag</b>
V	0731	Gloeilampen (VM)	fl
B	9950	Richtbankbedrag (HM)	fl
B	9952	Richtbank aanpassen + vtg. op en af	
B	0245	Richten voorzijde	
B	2695	Richten achterzijde	
B	1477	Richten zijkant L.	
B	1478	Richten zijkant R.	
B	0247	Dé-/montage t.b.v. spuitwerk	
B	9951	Dé-/montage delen LPG-installatie	
V	9987	Koelvloeistof (VM)	fl
V B	0734	Antenne (VM)	fl
V B	2709	Trekhaak (VM)	fl
<b>*** Vrije deel</b>			
			fl
			fl
			fl
			fl
			fl
R	Risico		fl

Fantoom	Uitvoeringsspecificaties	Speciaal rapport
<b>Mark</b>		Resultatenblad 1
		Controleblad 1 2
		Oude prijs A
		Prisdatum
		Tekst font 1 Lang 2
		Geen spijl L

R Risico <div style="float: right;"> <input type="checkbox"/> <input type="checkbox"/> <input type="checkbox"/> </div>		
↓ aant. - X -    + aant. - X - zones    = Totaal aant. - X -		
* Voor codes zie "Audatex-codekaart" <input type="checkbox"/> Alleen i.c.m. AZT ** Alleen te gebruiken bij vervanging carrosserie *** Naar keuze invullen V,GV,B,H,GH,C,SV,SH,S of O		
Serie: 1	Wijzigingsdatum	(081293)
<b>Fiat</b>	<b>Ducato [290]</b>	<b>872</b>

0419	VB
0420	VB
0476	VB
0477	VB
0478	VB
0461	VB
0462	VB
0429	VB
0430	VB
0437	VB
0593	V
0594	V
0496	V
0410	VB
H09203S	VB
0475	V
0476	V
0509	V
HT3513S	V
1453	VB
1454	VB
1457	V
1458	V
1401	VB
1410	V
0628	V
2427	VB
2428	VB
H23513S	V

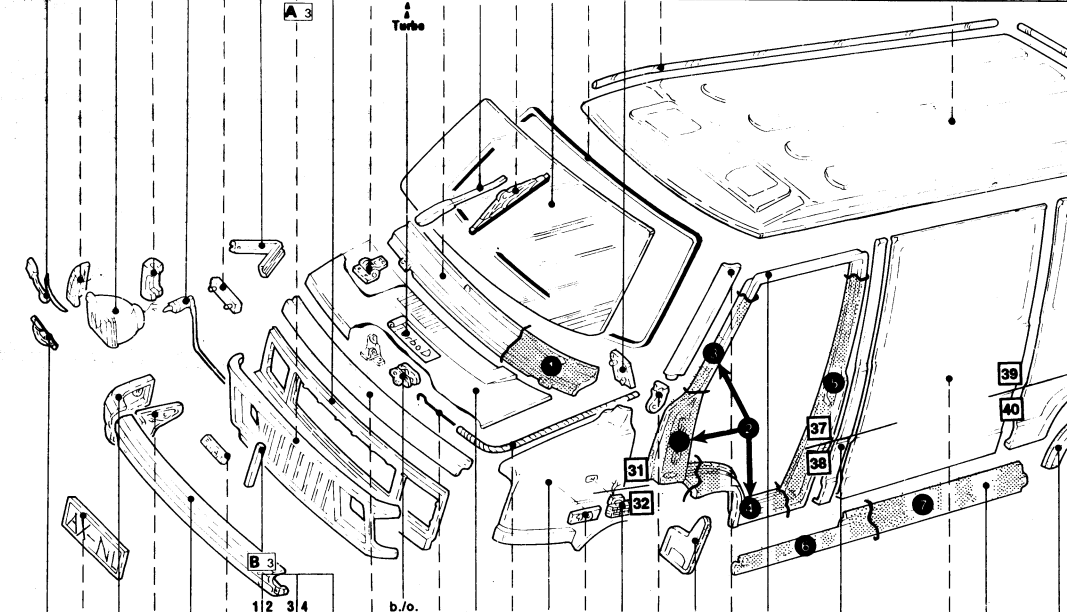

0621	V
0622	V
0256	VB
0291	VB
0292	VB
H0317	V
H0318	V
H0282	VB
0435	V
0421	V
0422	V
0423	V
0424	V
0425	V
H0381	VB
0493	V
0494	V
0500	V
H0471	VB
0502	V
H07413S	V
H07423S	V
0811	VB
0812	VB
0707	VB
0708	V
0501	V
0897	VB
0898	VB
H22653S	V
H22663S	V
20853S	V
20863S	V
H22793S	V
H22803S	V
H34793S	V
H21013S	V
H21023S	V
3677	VB
3678	VB
H34813S	V
H34823S	V
3683	VB
3684	VB
H27213S	V
H27223S	V
H35713S	V
H35723S	V
3069	V
3070	V
H27133S	V
3074	VB
2996	V
2985	V
2988	V
H3063	V
H3064	V
H3061	V
H3062	V
H2933	VB
H2934	VB
3051	V
3052	V
3049	V
3050	V
3056	V
3056	V
3059	V
3060	V
H2617	V
H2582	VB
2601	V
2602	V
2591	VB
2592	VB
3281	VB
3282	VB
GH13753S	GV
GH13763S	GV
13893	GV
GH22373S	GV
GH22383S	GV
GH22413S	GV
GH22423S	GV
GH22433S	GV
GH22443S	GV

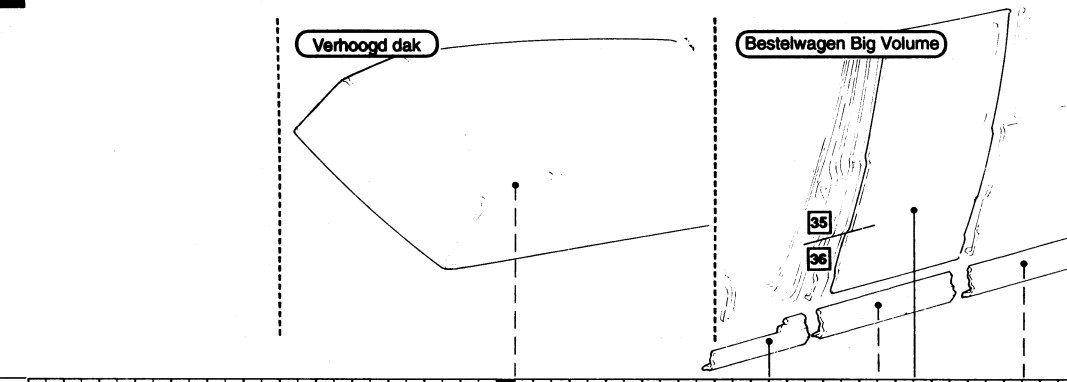

H23513S	V
H21013S	V
H21023S	V
H21073S	V
H21083S	V
H34773S	V
H34783S	V
H21093S	V
H21103S	V
4907	VB
2996	V
2999	V
3000	V
2997	V
2998	V
2978	V
2944	VB
2945	V
2946	V
3001	V
3002	V
H2931	VB
2953	V
2954	V
2951	V
2952	V
2959	V
2960	V
2955	V
2956	V
2957	V
2979	V
2981	V
1780	V
3161	V
3160	VB
3161	VB
3726	VB
3227	V

2429	VB
3071	V
3072	V
3065	VB
3066	VB
2973	V
3067	V
3068	V
3073	V
2977	V
2975	V
2984	V
2979	VB
2963	V
2964	V
2965	V
2966	V
3183	V
3184	V
3152	VB
3153	VB
3053	V
3054	V
3057	V
3058	V
3017	VB
3023	VB
3011	VB
2981	V
1780	V
2701	VB
3361	VB
GH08513S	SH
GH08523S	SH
GH08473S	SH
GH08483S	SH
GH37493S	SH
GH37473S	SH
GH37493S	SH
GH37503S	SH

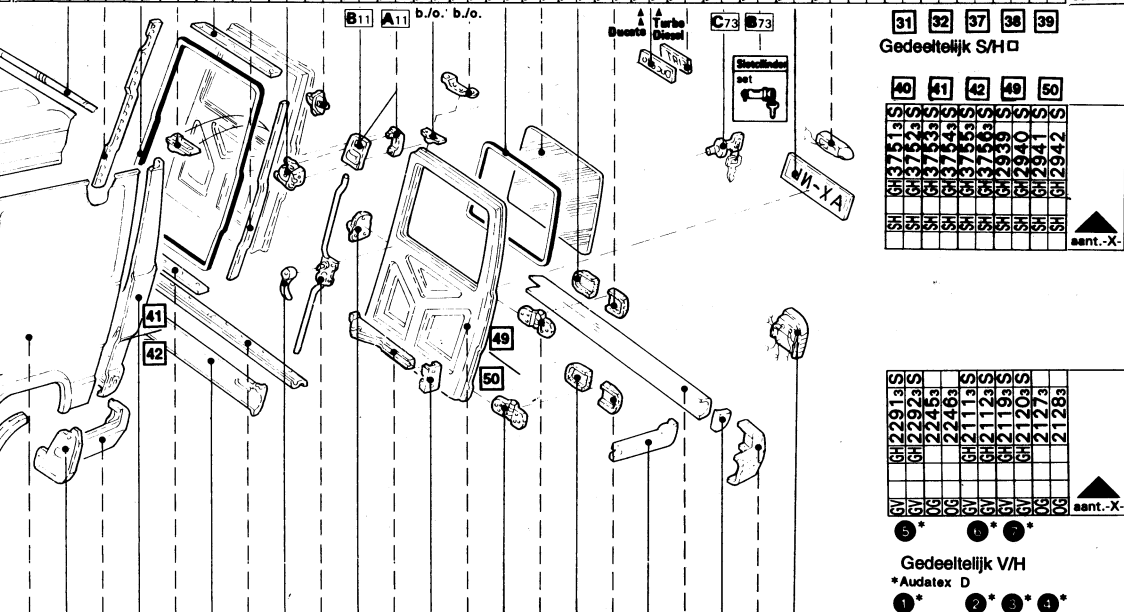

GH22913S	GV
GH22923S	GV
2245	GV
2246	GV
22463	GV
GH21113S	GV
GH21123S	GV
GH21193S	GV
GH21203S	GV
21273	GV
21283	GV
GH13753S	GV
GH13763S	GV
13893	GV
GH22373S	GV
GH22383S	GV
GH22413S	GV
GH22423S	GV
GH22433S	GV
GH22443S	GV

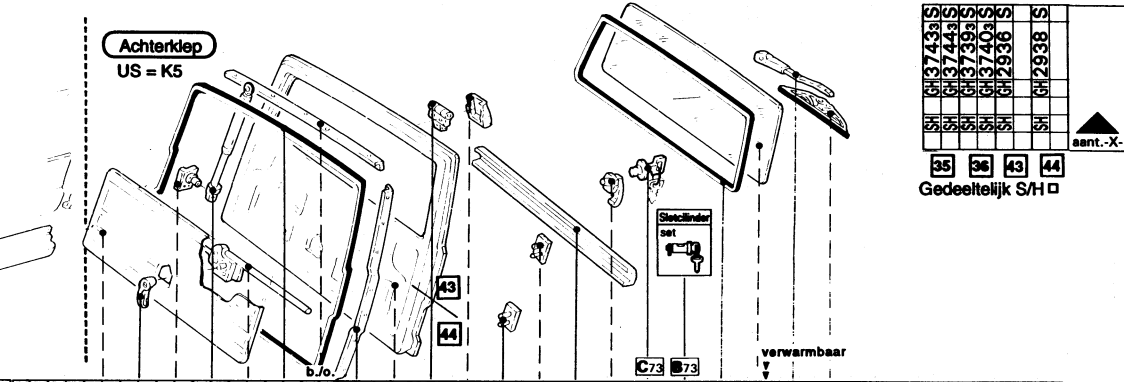

GH37433S	SH
GH37443S	SH
GH37453S	SH
GH37463S	SH
GH37473S	SH
GH37483S	SH
GH2938	SH
GH2938	SH













Zitplaatsen  
zie ook zone 20

Minibus



rijen

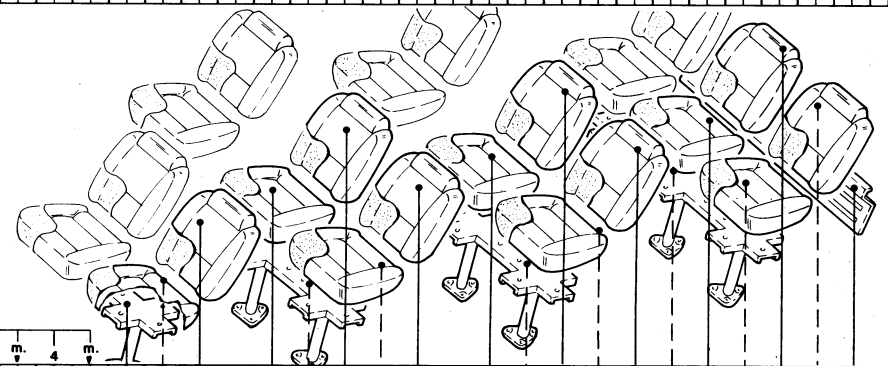

V	H4657	
V	H4658	
V	H4743	
V	H4744	
V	H4745	
V	H4797	
V	H4798	
V	H4799	
V	H4801	
V	H4802	
V	H4800	
V	H4803	
V	4681	
V	4682	
V	4703	
V	4704	
V		
V	4757	
V	H4805	
V	H4806	
V	4771	
V	4755	
V	4756	
V	4769	
V	4770	
V		
V	4789	
V	H4807	
V	H4808	
V	4790	
V	4787	
V	4788	
V	4791	
V	4792	
V	H4809	
V		
V	4835	
V	4833	
V	4834	
V	4839	
V	4837	
V	4838	
V	4775	





19

V/B	0481
V	4860
V/B	1322
V/B	4875
V	2191
V/B	4941
V/B	4942
V	2193
V	2194
V	4947
V	1509
V/B	4951
V/B	4952
V/B	4949
V/B	4950

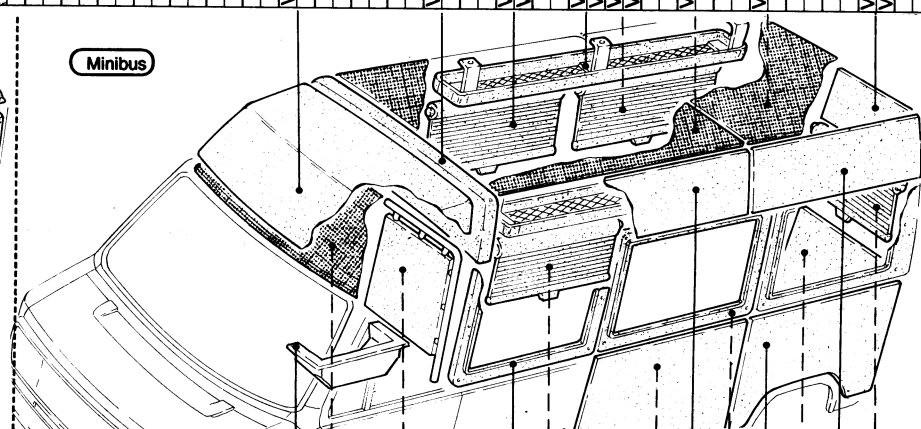
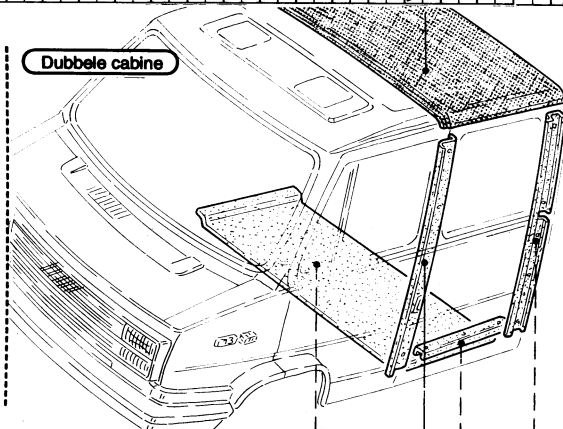
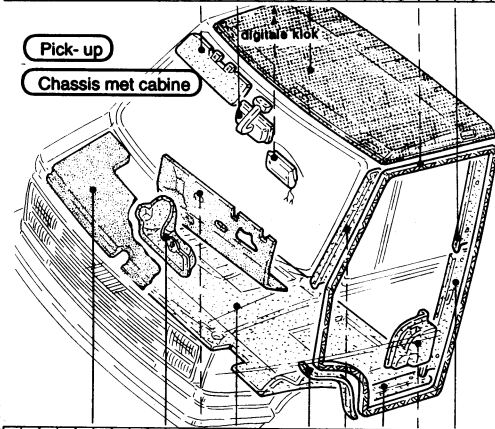

V/B	4933
V/B	4934
V/B	4931
V	4390
V/B	4957
V	1509
V/B	4951
V/B	4952

V/B	4958
-----	------

V/B	4930
V/B	4929
V/B	4869
V/B	4870
V/B	4865
V/B	4866
V/B	4871
V/B	4872
V/B	4958
V/B	4959
V/B	4911
V/B	4912

V/B	0481
V	4860
V/B	1322
V/B	4875
V/B	2191
V/B	2192
V/B	7634
V/B	2193
V/B	2194
V/B	4947
V/B	4948
V	4891
V	4892
V	4893
V	4894
V	4895
V	4896
V	4897
V	4898
V/B	H 4617 S
V	H 4624 S
V/B	H 4615
V	H 4619
V	H 4620

V/B	0481
V	4860
V/B	1322
V/B	4875
V	4877
V/B	2191
V/B	2192
V/B	2193
V/B	2194
V/B	4876
V/B	4947
V/B	4948
V	7634
V/B	4900
V/B	4978
V/B	4979
V	4903
V/B	4904
V/B	4991
V/B	4992
V/B	4901
V/B	4902
V/B	4983
V/B	4984

V/B	4390
V	4933
V	4934
V	4931
V/B	4880
V/B	4965
V/B	4941
V/B	4942
V/B	4966
V/B	1509
V/B	1510
V/B	4957
V/B	4958
V/B	4913
V/B	4959
V/B	4917
V/B	4918
V/B	4930

18

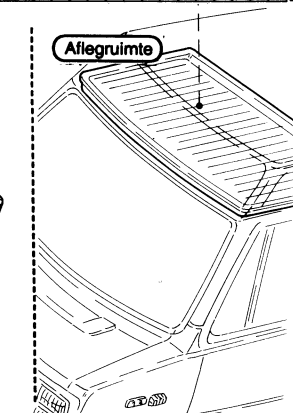
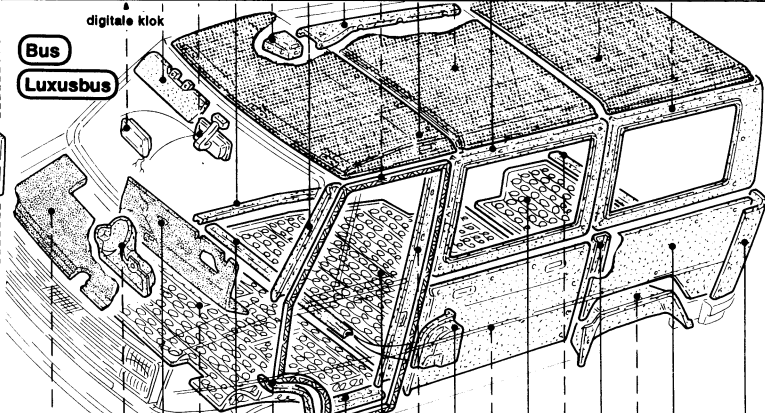
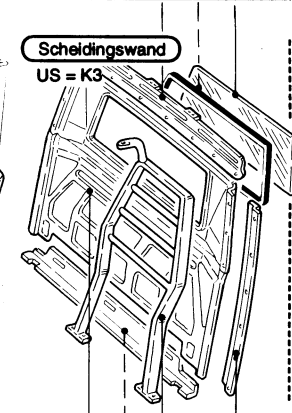
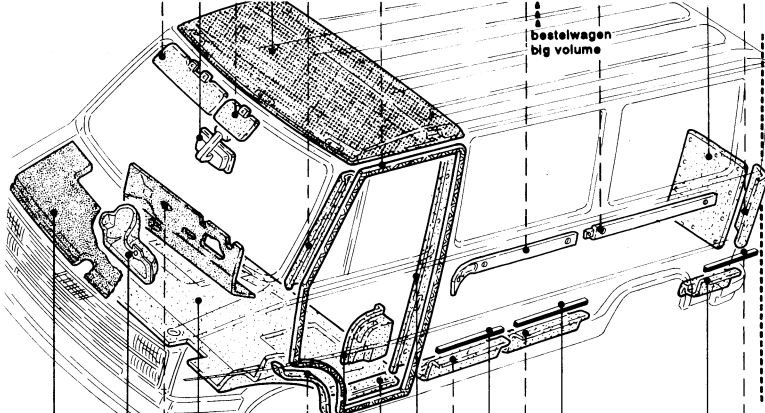

V	4933
V	4934
V	4931
V	4936
V/B	4957
V/B	4941
V/B	4942
V/B	1509
V/B	1510
V	4861
V	4862
V	4863
V	4864
V/B	4909
V/B	4910
V/B	4983
V/B	4984
V	H 4618 S
V	4622
V/B	4621

V	4390
V	4933
V	4934
V	4931
V/B	4880
V/B	4965
V/B	4941
V/B	4942
V/B	4966
V/B	1509
V/B	1510
V/B	4957
V/B	4958
V/B	4913
V/B	4959
V/B	4917
V/B	4918
V/B	4930

20	V/B H4495	V/B H4496	V 4661	B 4661.3	B 4662.3	V 4689	V 4690	V 4697	V 4698	V/B H4496	V 4681	B 4681.3	B 4682.3	B 4686.3	V 4699	V/B H4663	V 4721	B 4721.3	B 4722.3	V 4826	V 4827	V 4828	V/B H4657	V/B H4658	V/B H4659	V 4721	B 4721.3	B 4722.3	V 4651	V 4652	V 4705	V 4726	V 4727	V 4728	V 4723	V 4724	V 4771	V 4826	V 4827	V 4828	V/B H4743	V/B H4744	V/B H4745	ant.-X
----	-----------	-----------	--------	----------	----------	--------	--------	--------	--------	-----------	--------	----------	----------	----------	--------	-----------	--------	----------	----------	--------	--------	--------	-----------	-----------	-----------	--------	----------	----------	--------	--------	--------	--------	--------	--------	--------	--------	--------	--------	--------	--------	-----------	-----------	-----------	--------

set

**Passagiersbank US = L3**

Bank compl. zonder bekleding

Veiligheids gordel voor

**Combi/ Bus Dubbele cabine**

Stoelrj compl. zonder bekleding

Veiligheids gordel midden

**Combi/ Bus**

Stoelrj compl. zonder bekleding

Veiligheids gordel achter

**Luxusbus**

Stoel compl. zonder bekleding

Veiligheids gordel midden

Stoelrj compl. uit + in

Stoelrj compl. uit + in

Veiligheids gordel achter

ant.-X

20	H4561	H4562	H4549	H4550	H4543	H4544	H4545	H4546	4536	4552	4536	H4546	4590	4596	4679	4701	4726	4727	4728	4707	4758	4768	H4742	4841	B 4841.3	B 4842.3	B 4663.3	H4320	H4321	4663	H4327	H4328	4681	4682	4703	4704	B 4742.3	4757	H4322	H4323	4766	4766	H4329	H4330	4769	4770	H4775	4841	B 4841.3	B 4842.3	ant.-X
----	-------	-------	-------	-------	-------	-------	-------	-------	------	------	------	-------	------	------	------	------	------	------	------	------	------	------	-------	------	----------	----------	----------	-------	-------	------	-------	-------	------	------	------	------	----------	------	-------	-------	------	------	-------	-------	------	------	-------	------	----------	----------	--------

ant.-X

21	4445	4431	4429	4430	4428	4423	4419	4437	4438	4441	4442	4331	4365	4369	4427	4425	4426	4365	4367	4480	4481	4443	4448	4449	4487	4486	4485	4488	4489	4465	4396	4395	4457	4393	4394	4467	4483	ant.-X
----	------	------	------	------	------	------	------	------	------	------	------	------	------	------	------	------	------	------	------	------	------	------	------	------	------	------	------	------	------	------	------	------	------	------	------	------	------	--------

**Extra verwarming voor US = F7**

**Extra verwarming achter US = I5**

**Airconditioning US = F1**

ant.-X

8851	
8852	
8501	
8502	
8979	
8864	
8863	
8873	
8872	
8677	
8674	
8913	
8949	
8917	
8951	

Wisselbak

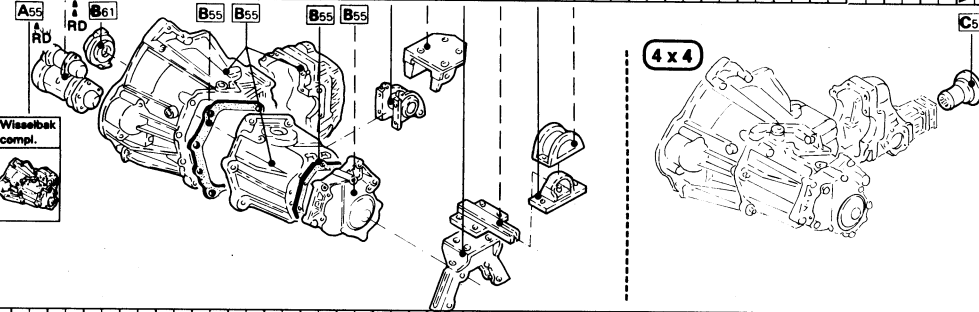

4 x 4

C95



79002	
82812	
82832	
79312	
8632	
8622	
8433	
8417	
8422	
8411	
8412	
8428	
7855	
82732	
7831	
80012	
80022	
80272	
83112	
82662	
80322	
7880	
7876	
7813	
8457	
8451	
8453	
8467	
79412	
79612	
83312	
83512	
8801	
8807	
7881	
8373	

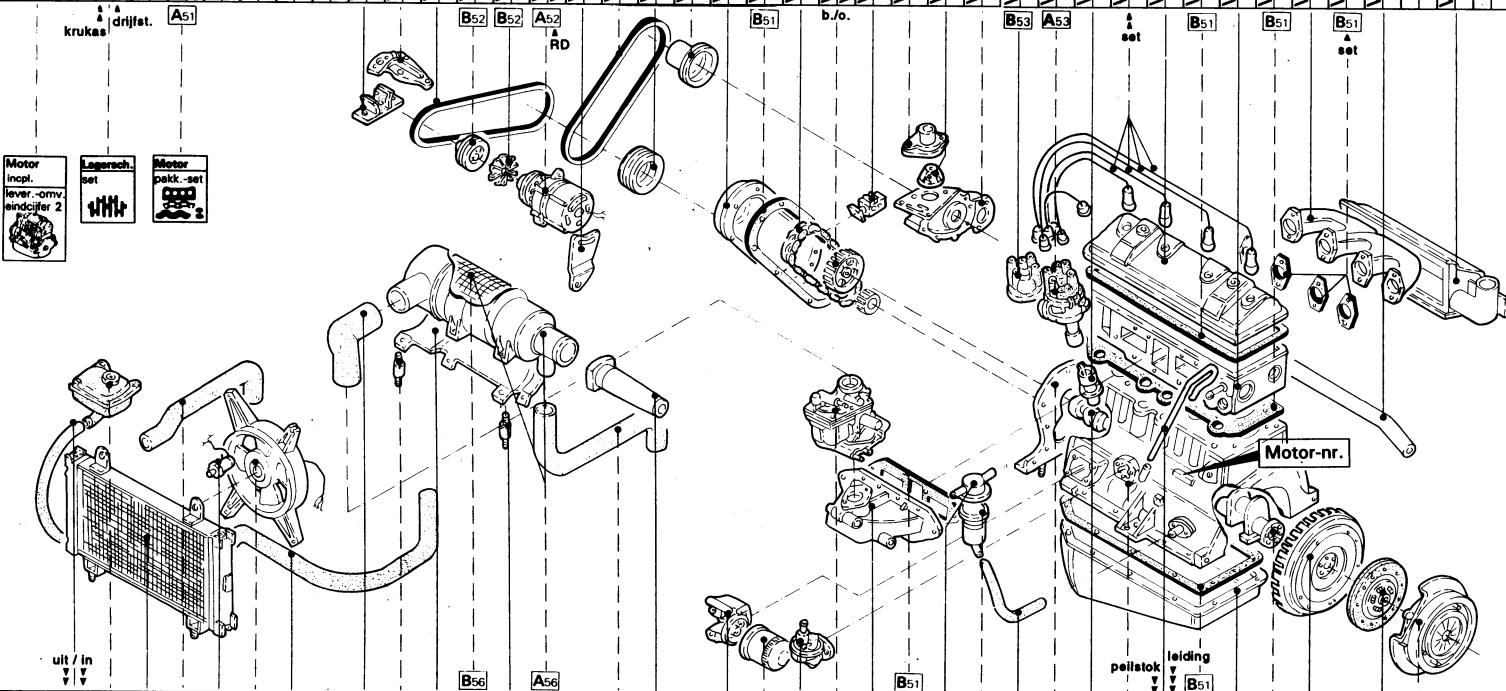

Ventilator

Chassis met cabine ,comfort US = L4

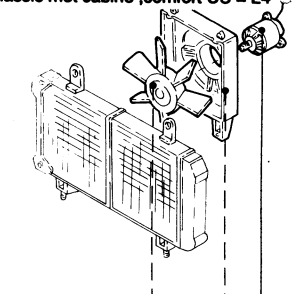

7788	
7789	
7787	
7761	
7776	
7766	
7790	
7773	
8371	
8406	
8408	
8397	
8395	
8405	
8407	
8391	
8374	
8388	
80372	
80412	
8091	
8191	
8221	
8241	
7992	
7996	
7997	
80332	
83012	
79202	
8045	
8048	
80752	
80652	
82632	
8970	
8975	
8971	

7793	
7767	
7790	









28

28

29

29

**Rembekrachtiger**

Maxi  
Turbo-Diesel 2,5 ltr. US = N5

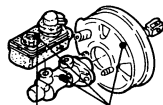

B74

compl.  
A74

**Stuurbekrachtiging**

US = Q1

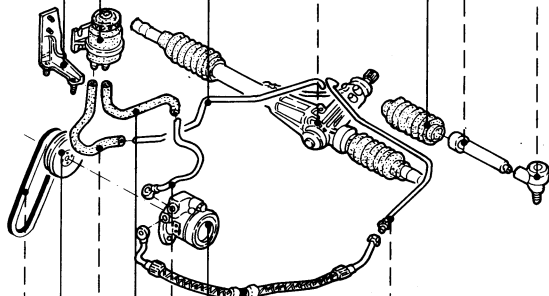

V 7478

V 7479

V 7481

V B/C 7300

V 7327

V 7309

V 7310

V 7311

V 7312

A72

B72

B72

**4 x 4**

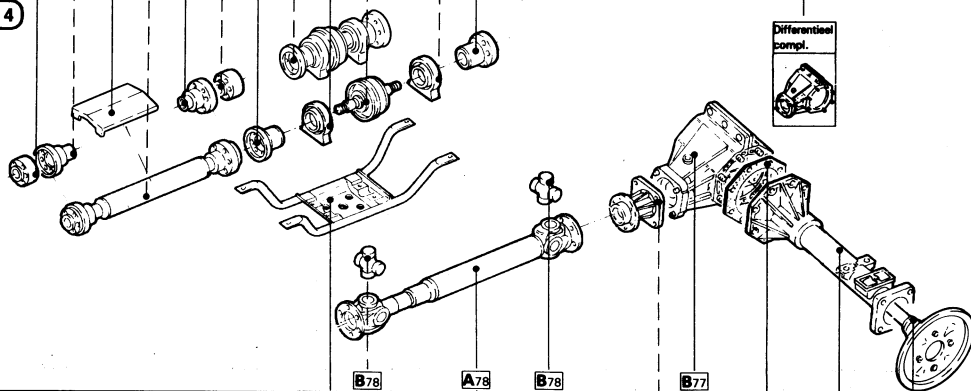

B75

B75

A75

B75

B75

B76

A76

B76

B76

B76

B76

A77

V 9489

V 9490

V H 9499

V C 9475

V 9492

V 9491

V 9483

V 9485

V C 9487

V 9486

V 9488

V 9484

V 9421

V 7519

V B 7504

V 7477

V 7473

V 7485

V 7486

V 7482

V 7461

V 7483

V 7484

V H 9494

V 9479

V C 9476

V 9480

V 9433

V 9423

V 9429

V 9430

V 9431

V 9432

V 9265

V 9266

aant.-X-

aant.-X-

aant.-X-

aant.-X-

Gebruikersnummer \_\_\_\_\_ • \_\_\_\_\_ Volg-nr. \_\_\_\_\_  
Rapportnummer \_\_\_\_\_  
Bezichtigingsdatum \_\_\_\_\_

Nederland BV  
**audatex**

11.02.94

© Copyright AUDATEX 1994

AUDATEX Nederland BV  
Handelsweg 6  
Postbus 124  
3700 AC Zeist

TEL: 03404/35800  
FAX: 03404/15859

**Algemene gegevens**

**Opmerkingen**

Werkzaamheid \_\_\_\_\_  
Polisnummer \_\_\_\_\_  
Schadenummer \_\_\_\_\_  
Schadedatum \_\_\_\_\_  
Opdrachtdatum \_\_\_\_\_

Expertise-adres \_\_\_\_\_ (V/T/R/C)  
Eigenaar \_\_\_\_\_ (V/T)  
(V = VERZEKERDE / T = TEGENPARTIJ / R = REPARATEUR / C = CONTACTPERSOON)

**Verzekerde**  
Naam \_\_\_\_\_  
Straat/Nr. \_\_\_\_\_  
PC/Plaats \_\_\_\_\_  
Tel.nr./Land \_\_\_\_\_ N.L.  
Vrije tekst \_\_\_\_\_

**Tegenpartij**  
Naam \_\_\_\_\_  
Straat \_\_\_\_\_  
PC/Plaats \_\_\_\_\_  
Tel.nr./Land \_\_\_\_\_ N.L.  
Vrije tekst \_\_\_\_\_

**Objectgegevens**  
Object \_\_\_\_\_  
Merk \_\_\_\_\_  
Model/Type \_\_\_\_\_  
Kenteken/Land \_\_\_\_\_ N.L.  
Chassisnummer \_\_\_\_\_  
Cat.waarde \_\_\_\_\_ (incl. BTW)

Kleur \_\_\_\_\_  
Soort brandst. \_\_\_\_\_  
Afgifte deel 1 \_\_\_\_\_  
Afgifte deel 2 \_\_\_\_\_  
Bouwjaar 19\_\_\_\_\_  
Toestand voert. \_\_\_\_\_ (1 = Goed 2 = Redelijk 3 = Matig 4 = Slecht 5 = zie opm.)  
Km stand \_\_\_\_\_

**Schadegegevens**  
Schade bev.zich. \_\_\_\_\_  
Stootrichting \_\_\_\_\_ (00-12)  
Aangrijppunt \_\_\_\_\_ (A t/m K)  
Schade oorzaak \_\_\_\_\_ (A/B/D/H/S/V/W/O)  
Eerdere schade \_\_\_\_\_ (-/J/N)  
Reparatieduur \_\_\_\_\_ dagen  
Gezien door expert \_\_\_\_\_ (J/N)

**Polis-/Betaalgegevens**  
Verzek. bedrag \_\_\_\_\_  
Dekking/Branche \_\_\_\_\_ 2.0  
BTW-verrekenb. \_\_\_\_\_ (-/J/N)  
Betaalgar./ber. \_\_\_\_\_ (-/J/N)  
Akte van cessie \_\_\_\_\_ (-/J/N)

**Overige gegevens**  
Opdrachtgever \_\_\_\_\_  
Correspondent \_\_\_\_\_  
Telefoonnr. \_\_\_\_\_  
Tussenpersoon \_\_\_\_\_  
Erkenningsnr. \_\_\_\_\_

**Reparateur/Contactpersoon**  
Naam \_\_\_\_\_  
Straat \_\_\_\_\_  
Nr./Toevoeging \_\_\_\_\_  
PC/Plaats \_\_\_\_\_  
Tel.nr./Land \_\_\_\_\_ N.L.

**Aangrijppunt/Stootrichting**

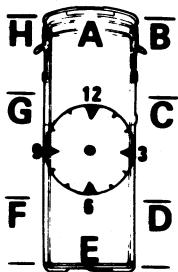

I boven zijde J onder zijde K totaal verlies

**Akkoord \***

**Expert**  
Handtekening/  
Stempel

**Reparateur**  
Handtekening/  
Stempel

**audatex** AEF-nr. 872

\* betreft akkoord voor de vastlegging van de schade op dit formulier