

AEF-nr.	Fabrikant	Model	Nederland BV				Eigenaar	Kenteken				Expert					
335	Mercedes-Benz	260 SE-560 SEC 10/79-03/91	audatex © Copyright AUDATEX 1991 20.06.86														
Type	Code X	Uitvoeringsspecificatie Code X	Uitvoeringsspecificatie Code X	Uitvoeringsspecificatie Code X	Uitvoeringsspecificatie Code X	Tarieven											
STANDAARD INVOERGERGEVENS						Arbeidertarief per AE	Spuittarief per AE				Excl. materiaal Incl. materiaal						
Sedan		▼ carburateurmotor 2,8 ltr. 115 kW	M 5	standverwarming glas rondom getint	F 3	▼											
260 SE	(126.020)	335 08		voorraad met zonw.band	F 8	stuurwiel leer	Q 2										
280 S	(126.021)	335 01		buitensp. r. mech. verstelb.	G 7	stuurkolom elektr. verst.	Q 3										
280 SE	(126.022)	335 02		buitensp. r. elektr. verst.	G 8	niveauregeling	Q 4										
280 SEL	(126.023)	335 03		buitensp. r. elektr. verst./verw.	G 9	autom. sperddifferentieel (ASD)	Q 5										
300 SE	(126.024)	335 09		centrale vergrendeling	G 1	hydropneumat. vering	Q 6										
300 SEL	(126.025)	335 10		ruitbed. elektr. v. + a.	G 2	anitblokkeersysteem (ABS)	Q 7										
380 SE	(126.032)	335 04		ruitbed. elektr. v.	G 3	antislipregeling (ASR)	P 8										
380 SEL	(126.033)	335 05		▼		differentieel m. beperkte slip	P 9										
420 SE	(126.034)	335 11		radio	H 5	remsysteem ATE	V 6										
420 SEL	(126.035)	335 12		luidsprekers achter	H 6	remsysteem Bendix	V 7										
500 SE	(126.036)	335 06		antenne a. mechanisch	H 8	remsysteem Girling	V 5										
500 SEL	(126.037)	335 07		antenne a. automatisch	H 9	airbag voor bestuurder	Q 8										
560 SE	(126.038)	335 14		extra verstralers	I 1	en passagier	L 7										
560 SEL	(126.039)	335 13		mistlampen	I 4	tempomaat	Q 9										
				knipperlichten zijkant	I 3	reiscomputer	L 4										
Coupé				koplampreinigings installatie	I 6	toerenteller	L 6										
380 SEC	(126.043)	335 21		▼		buitentemperatuurmeter	L 5										
420 SEC	(126.046)	335 22		bekleding stof	J 1	diefst./inbraak alarminst.	M 1										
500 SEC	(126.044)	335 23		bekleding MB-Tex (kunstleer)	J 2												
560 SEC	(126.045)	335 24		bekleding velours	J 3	▼ velgen											
				bekleding leer	J 4	6 J x 14 staal	S 1										
				bekleding Amaretta	I 5	6 1/2 J x 14 staal	S 2										
				stoelverwarming voor	J 7	7 J x 15 staal	S 3										
				stoelverwarming achter	K 6	6 J x 14 lichtmetaal	S 4										
				stoel v. r. hoogte verstelb.	J 8	6 1/2 J x 14 lichtmetaal	S 5										
				stoel v. l. elektr. verstelb.	K 1	7 J x 15 lichtmetaal	S 6										
				stoel v. r. elektr. verstelb.	K 2												
				met memory	K 3	▼ banden											
				stoel v. r. elektr. verstelb.	K 4	195/70 R 14..H	R 1										
				met memory	K 4	195/70 VR 14	R 2										
				armleuning v. opklapbaar	K 5	205/70 VR 14	R 6										
				armleuning a. opklapbaar	K 8	205/65 VR 14	R 4										
				achterbank elektr. verstelb.	K 7	205/65 R 15..H	R 3										
				wortelnotenhout uitvoering	K 9	205/65 VR 15	R 5										
				▼		205/55 R 16..T	R 8										
				uitstaplichten portieren	M 3	215/65 VR 15	R 7										
				asbak met sigaretten- aansteker in portieren a.	M 4	225/50 R 16..T	U 5										
				zonneklep met spiegelverlichting	M 2	225/50 VR 16	U 6										
				hoofdsteunen achter	L 1	235/55 VR 15	U 7										
				leeslampen achter	L 3												
				jalouzie elektr. in achterruit	L 2												
Fantom		Uitvoeringsspecificaties				Speciaal rapport											
Merk						Resultatenblad	1										
						Controleblad	1	2									
						Oude prijs	A										
						Prijsdatum											
						Tekst kort	1	Lang	2								
						Geen spuitw.	L										
Onderdelen*						Arbeidsloon*						Spuitloon*					
Arbeidsloon*						Spuitmateriaal						Anti - roest					
Spuitmateriaal						behandeling						Uitlijnen					
Anti - roest						Hulpstoffen						Bewerking					
behandeling						Uitlijnen						Benaming					
Uitlijnen						Hulpstoffen						▼AE % Bedrag					
Hulpstoffen						V						B					
Bewerking						B						H					
V						H						H					
B						H						H					
H						H						B					
H						B						V					
B						V						V B					
V						B						V B					
V B						***						Vrije deel					
V B						R						R					
R						L						* Voor codes zie "Audatex-codekaart" □ Alleen i.c.m. AZT					
L						** Alleen te gebruiken bij vervanging carrosserie						*** Naar keuze invullen V,GV,B,H,GH,C,SV,SH,S of O					
R						Serie: 3						Wijzigingsdatum 22.11.91 (190991)					
L						Mercedes-Benz						260 SE-560 SEC 335					

12

4571	V
4572	V
4661	V
4662	V
4653	V
4654	V
4655	V
4656	V
4657	V
4658	V
4611	V
4553	V
4554	V
4567	V
4568	V
4589	V
4590	V
4585	V
4586	V
4597	V
4598	V
4595	V
4596	V
4602	V
4606	V
4835	V
4836	V
4837	V
4718	V
4701	V
4785	V
4786	V
4727	V
4728	V
4841	V
4842	V
4840	V

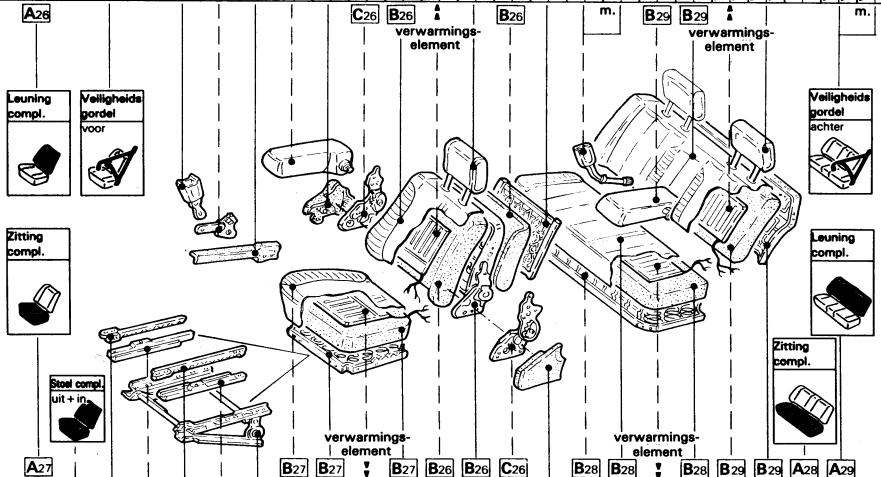

4507	V
4508	V
44963	B
44963	B
44561	V
44562	V
44563	V
44564	V
44565	V
44566	V
44544	V
44557	V
44558	V
44559	V
44560	V
44561	V
44562	V
44563	V
44564	V
44565	V
44566	V
44567	V
44568	V
44569	V
44570	V
44571	V
44572	V
44573	V
44574	V
44575	V
44576	V
44577	V
44578	V
44579	V
44580	V
44581	V
44582	V
44583	V
44584	V
44585	V
44586	V
44587	V
44588	V
44589	V
44590	V
44591	V
44592	V
44593	V
44594	V
44595	V
44596	V
44597	V
44598	V
44599	V
44600	V
44601	V
44602	V
44603	V
44604	V
44605	V
44606	V
44607	V
44608	V
44609	V
44610	V
44611	V
44612	V
44613	V
44614	V
44615	V
44616	V
44617	V
44618	V
44619	V
44620	V
44621	V
44622	V
44623	V
44624	V
44625	V
44626	V
44627	V
44628	V
44629	V
44630	V
44631	V
44632	V
44633	V
44634	V
44635	V
44636	V
44637	V
44638	V
44639	V
44640	V
44641	V
44642	V
44643	V
44644	V
44645	V
44646	V
44647	V
44648	V
44649	V
44650	V
44651	V
44652	V
44653	V
44654	V
44655	V
44656	V
44657	V
44658	V
44659	V
44660	V
44661	V
44662	V
44663	V
44664	V
44665	V
44666	V
44667	V
44668	V
44669	V
44670	V
44671	V
44672	V
44673	V
44674	V
44675	V
44676	V
44677	V
44678	V
44679	V
44680	V
44681	V
44682	V
44683	V
44684	V
44685	V
44686	V
44687	V
44688	V
44689	V
44690	V
44691	V
44692	V
44693	V
44694	V
44695	V
44696	V
44697	V
44698	V
44699	V
44700	V
44701	V
44702	V
44703	V
44704	V
44705	V
44706	V
44707	V
44708	V
44709	V
44710	V
44711	V
44712	V
44713	V
44714	V
44715	V
44716	V
44717	V
44718	V
44719	V
44720	V
44721	V
44722	V
44723	V
44724	V
44725	V
44726	V
44727	V
44728	V
44729	V
44730	V
44731	V
44732	V
44733	V
44734	V
44735	V
44736	V
44737	V
44738	V
44739	V
44740	V
44741	V
44742	V
44743	V
44744	V
44745	V
44746	V
44747	V
44748	V
44749	V
44750	V
44751	V
44752	V
44753	V
44754	V
44755	V
44756	V
44757	V
44758	V
44759	V
44760	V
44761	V
44762	V
44763	V
44764	V
44765	V
44766	V
44767	V
44768	V
44769	V
44770	V
44771	V
44772	V
44773	V
44774	V
44775	V
44776	V
44777	V
44778	V
44779	V
44780	V
44781	V
44782	V
44783	V
44784	V
44785	V
44786	V
44787	V
44788	V
44789	V
44790	V
44791	V
44792	V
44793	V
44794	V
44795	V
44796	V
44797	V
44798	V
44799	V
44800	V
44801	V
44802	V
44803	V
44804	V
44805	V
44806	V
44807	V
44808	V
44809	V
44810	V
44811	V
44812	V
44813	V
44814	V
44815	V
44816	V
44817	V
44818	V
44819	V
44820	V
44821	V
44822	V
44823	V
44824	V
44825	V
44826	V
44827	V
44828	V
44829	V
44830	V
44831	V
44832	V
44833	V
44834	V
44835	V
44836	V
44837	V
44838	V
44839	V
44840	V
44841	V
44842	V
44843	V
44844	V
44845	V
44846	V
44847	V
44848	V
44849	V
44850	V
44851	V
44852	V
44853	V
44854	V
44855	V
44856	V
44857	V
44858	V
44859	V
44860	V
44861	V
44862	V
44863	V
44864	V
44865	V
44866	V
44867	V
44868	V
44869	V
44870	V
44871	V
44872	V
44873	V
44874	V
44875	V
44876	V
44877	V
44878	V
44879	V
44880	V
44881	V
44882	V
44883	V
44884	V
44885	V
44886	V
44887	V
44888	V
44889	V
44890	V
44891	V
44892	V
44893	V
44894	V
44895	V
44896	V
44897	V
44898	V
44899	V
44900	V

Stoelverstelling elektr.
US = K1-K4, K7

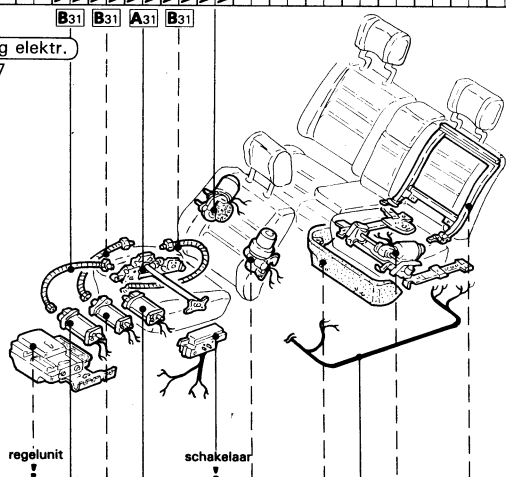

4613	V
4614	C
4627	C
4628	C
4629	C
4630	C
4625	C
4626	C
4645	V
4646	V
4621	C
4622	C
4683	V
4684	V
4681	H
4801	V
4802	C
4805	V
4806	H
4667	H
4668	H
4681	V
4682	V
4711	V
4712	V
4675	V
4676	V
4785	V
4786	V
4765	V
4766	V
4827	V
4828	V
4831	V
4832	V
4825	V
4826	V
4663	V
4664	V

Achterbank gedeeld
Sedan US = K7
Coupé

verwarmings-element
Coupé Coupé

12

13

13

aant.-X

aant.-X

aant.-X

aant.-X

Gebruikersnummer _____ • _____ Volg-nr. _____
Rapportnummer _____
Bezichtigingsdatum _____

Nederland BV
audatex 20.06.86

© Copyright AUDATEX 1991

AUDATEX Nederland BV
Huis ter Heideweg 16
Postbus 124
3700 AC Zeist

TEL: 03404/12510
FAX: 03404/15859

Algemene gegevens

Opmerkingen

Polisnummer _____
Schadenummer _____
Schadedatum _____
Opdrachtdatum _____

Expertise-adres (V/T/R/C)
Eigenaar (V/T)
(V = VERZEKERDE / T = TEGENPARTIJ / R = REPARATEUR / C = CONTACTPERSOON)

Verzekerde

Naam _____
Straat/Nr. _____
PC/Plaats _____
Tel.nr./Land _____ N.L.
Vrije tekst _____

Tegenpartij

Naam _____
Straat _____
PC/Plaats _____
Tel.nr./Land _____ N.L.
Vrije tekst _____

Objectgegevens

Object _____
Merk _____
Model/Type _____
Kenteken/Land _____ N.L.
Chassisnummer _____
Cat. waarde _____ (incl. BTW)

Kleur _____
Bouwjaar 1,9
Afgifte deel 1 _____
Afgifte deel 2 _____
Toestand voert. (1 = Goed 2 = Redelijk 3 = Matig 4 = Slecht 5 = zie opm.)
Km stand _____

Schadegegevens

Schade bev. zich _____
Stootrichting (00-12)
Aangrijppunt (A t/m K)
Eerdere schade (-/J/N)
Reparatieduur dagen

Polis-/Betaalgegevens

Verzek. bedrag _____
Dekking/Branche 2,0
BTW-verrekenb. (-/J/N)
Betaalgar./ber. (-/J/N)
Akte van cessie (-/J/N)

Schade oorzaak (A/B/D/H/S/V/W/O)

Aangrijppunt/Stootrichting

Overige gegevens

Opdrachtgever _____
Correspondent _____
Telefoonnr. _____
Tussenpersoon _____

Reparateur/Contactpersoon

Erkenningsnr. _____
Naam _____
Straat _____
Nr./Toevoeging _____
PC/Plaats _____
Tel.nr./Land _____ N.L.

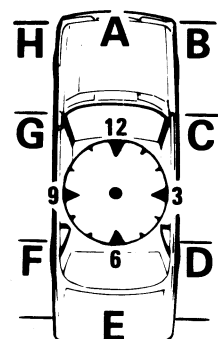

I boven zijde J onder zijde K totaal verlies

Akkoord *

Expert
Handtekening/
Stempel

Reparateur
Handtekening/
Stempel

audatex AEF-nr. 335

* betreft akkoord voor de vastlegging van de schade op dit formulier