

AEF-nr.	Fabrikant	Model	Nederland BV			Eigenaar				
G15	Mitsubishi	Lancer (C60) 09/88-	audatex © Copyright AUDATEX 1994			19.05.89				
Type	Code X	Uitvoeringsspecificatie Code X	Uitvoeringsspecificatie Code X	Uitvoeringsspecificatie Code X	Tarieven					
STANDAARD INVOERGEDEVENS		▼ bouwjaren			Arbeidstarief per AE		Spuittarief per AE		Excl. materiaal Incl. materiaal	
Sedan		v.a. mei '89 (model '90 L1) D 1	centrale vergrendeling G 1		Tekstzone codes					
Lancer EL	G15 05	v.a. november '89 (model '90 L1) D 2	ruitbediening elektrisch G 2		Onderdelen*					
Lancer GL	G15 03	v.a. juni '90 (model '91 M1) D 3	koplamphoogteregeling I 7		Arbeidsloon*					
Lancer GLi	G15 04	v.a. mei '91 (model '92 N1) D 4	mistlampen K 1		Spuitloon*					
Lancer GLXi	G15 01	v.a. november '91 (model '92 N1) D 5	▼		Spuitmateriaal				51	
		v.a. juni '92 (model '93 P1) D 6	stuurbechrachting Q 1		Anti - roest	70 fl		Kleinmateriaal	27 fl	
Hatchback		v.a. oktober '92 (model '93 P1) D 7	▼ banden		behandeling	71 fl	**	Aftrek 1 ^e schade	95 fl	
Lancer GL	G15 13		155 R 13 .. T R 1		Uitlijnen	74 fl		Begr. kosten rep.	90 fl	
Lancer GLi	G15 14	▼ carburateur	175/70 R 13 .. H R 5		Hulpstoffen	63 fl		Poetsen/reinigen	67 fl	
Lancer GLXi	G15 11	1298 ccm (1,3 ltr.) 51kW N 3	195/60 R 14 .. H R 7							
Lancer GTi-16V	G15 17	1298 ccm (1,3 ltr.) 55kW O 1								
		▼ inspuiting	▼ velgen							
		1298 ccm (1,3 ltr.) 55kW O 6	5 J x 13 S 1							
		1458 ccm (1,5 ltr.) 62kW N 5	5,5 J x 14 T 7							
		1458 ccm (1,5 ltr.) 66kW O 2	5,5 J x 14 lichtm. T 1							
		1597 ccm (1,6 ltr.) 83kW O 8								
		1836 ccm (1,8 ltr.) 100kW O 3								
		▼ diesel								
		1779 ccm (1,8 ltr.) 44kW N 8								
		▼ wisselbak								
		4-versnellingen P 1								
		5-versnellingen P 3								
		automatisch P 7								
		▼ lak								
		2-K-acryl (uni) rep.-lak Y 2								
		2-lagen-metallic Y 4								
		▼ spuitmethode								
		spuiten deel in uitgeb. toestand Y 8								
		voersp. uitgeb. afsp. gemonteerd Y 7								
		OPTIONELE INVOERGEDEVENS								
		▼								
		buitenspiegel mech. verst. G 6								
		buitenspiegel elektr. verst. G 7								
		buitenspiegel elektr./verwarmb. G 9								
		achterspoiler H 2								
Fantoom		Uitvoeringsspecificaties			Speciaal rapport					
Merk					Resultatenblad	1				
Model					Controleblad	1	2			
Type					Oude prijs	A				
					Prijdatum					
					Tekst kort	1	Lang	2		
					Geen spuitw.	L				
					R	Risico				fl
					↳ aant. - X - + aant. - X - zones = Totaal aant. - X -					
					* Voor codes zie "Audatex-codekaart" 1) 10 ^e positie v.h. chassisnummer					
					** Alleen te gebruiken bij vervanging carrosserie					
					*** Naar keuze invullen V,GV,B,H,GH,C,SV,SH,S of O					
					Serie: 4		Wijzigingsdatum 21.10.94		(170894)	
					Mitsubishi		Lancer		G15	

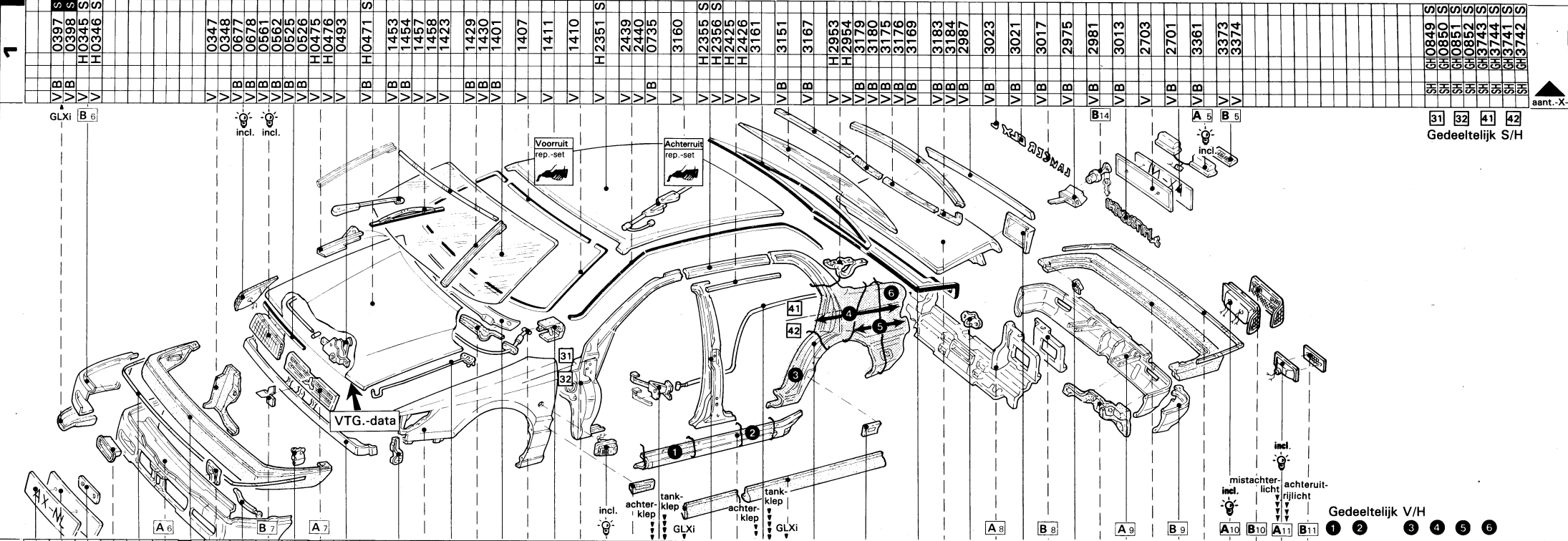

VB	0256	VB	0397 S
V	0258	VB	0398 S
V	0261	V	H0345 S
V	0351	V	H0346 S
V	0352		
V	0310		
VB	H0343 S		
VB	0281 S		
V	0317		
V	0318		
V	H0319		
V	H0320		
V	0431		
V	0329		
V	0330		
VB	0410 S		
V	H0427 S		
V	0831		
V	0832		
VB	H0741 S		
VB	H0742 S		
V	0495		
V	1393		
V	1394		
VB	1392		
V	0500		
V	0501		
V	H2227 S		
V	H2228 S		
VB	0707		
VB	0708		
VB	0775 S		
VB	0776 S		
V	2948		
V	2949		
VB	2211 S		
VB	2212 S		
V	H2277 S		
V	H2278 S		
V	H2101 S		
V	H2102 S		
V	2947		
V	2951		
VB	2213 S		
VB	2214 S		
V	H3481 S		
V	H3482 S		
VB	3613 S		
VB	3614 S		
V	2944		
VB	H2931 S		
VB	2976		
V	H2711 S		
VB	2995		
VB	2996		
V	H3571 S		
V	H3572 S		
V	2629		
V	2630		
V	2649		
V	2650		
VB	H2645 S		
VB	2581 S		
V	H2647 S		
V	H2648 S		
V	2610		
VB	3281		
VB	3282		
V	3291		
V	3292		
VB	3403		
VB	3298		
V	3405		
V	3300		
V	GH3111 S		
V	GH2112 S		
V	GH2119 S		
V	GH2120 S		
OG	2127		
OG	2128		
V	GH3493 S		
V	GH3494 S		
V	GH3541 S		
V	GH3542 S		
V	GH3537 S		
V	GH3538 S		
V	GH3539 S		
V	GH3540 S		
OG	3559		
OG	3560		

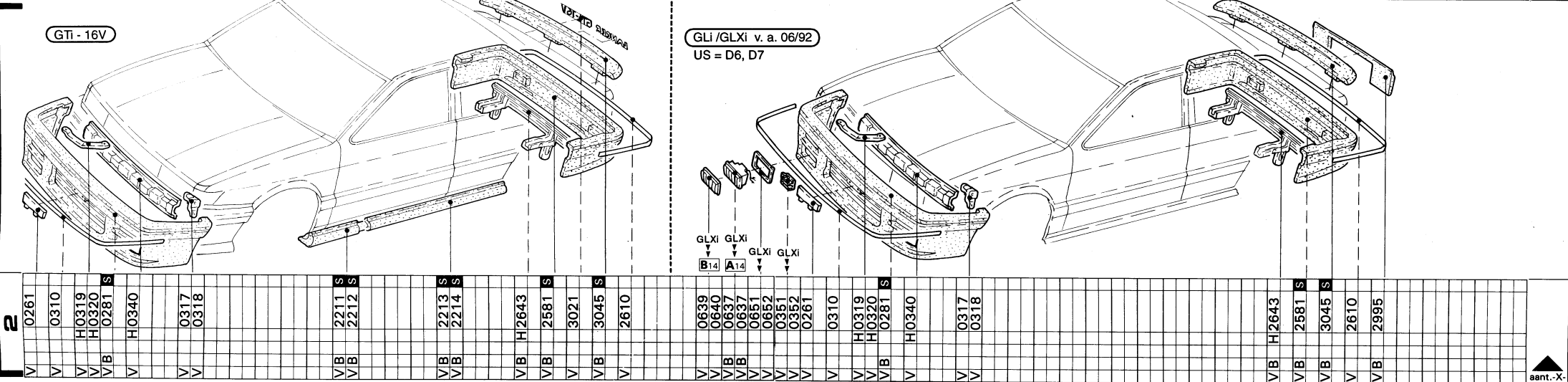

V	0261	VB	0397 S
V	0310	VB	0398 S
V	H0319	V	H0345 S
V	H0320	V	H0346 S
VB	0281 S		
V	H0340		
V	0317		
V	0318		
VB	2211 S		
VB	2212 S		
VB	2213 S		
VB	2214 S		
VB	H2643		
VB	2581 S		
V	3021		
VB	3045 S		
V	2610		
V	0639		
V	0640		
VB	0637		
VB	0637		
V	0651		
V	0652		
V	0351		
V	0352		
V	0261		
V	0310		
V	H0319		
V	H0320		
VB	0281 S		
V	H0340		
V	0317		
V	0318		
VB	H2643		
VB	2581 S		
VB	3045 S		
V	2610		
VB	2995		

10

V	4933
V	4934
V	4934
V	4941
VB	4942
VB	4957
V	1777
V	1778
VB	4951
VB	4952
VB	4963
VB	4964
V	2063
V	2064
V	2064
V	4987
VB	4978
VB	4971
VB	4972
VB	4927
VB	4929
VB	4930
VB	4985

VB	4921
VB	4852
VB	4919
VB	4920
VB	4913
VB	4907

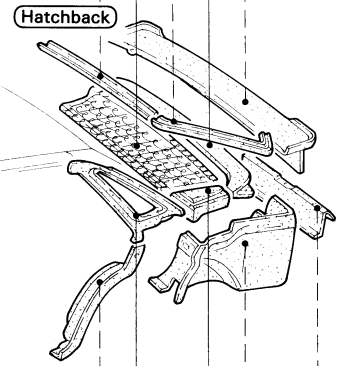
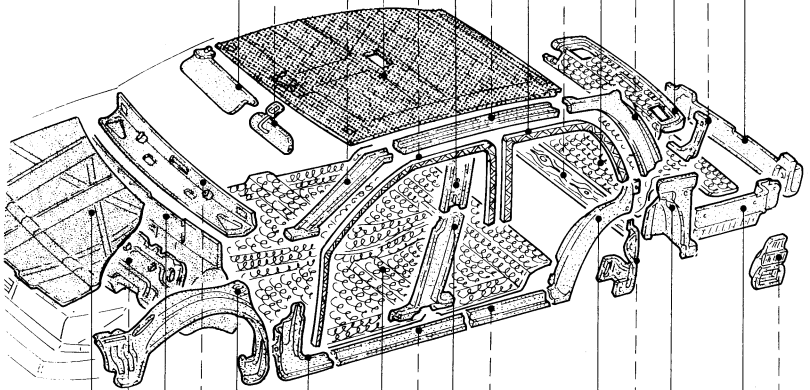

Hatchback

Diesel
Diesel

10

VB	0481
V	1326
V	1322
V	1324
VB	0841
VB	0842
VB	4939
VB	4940
VB	4873
VB	2191
VB	2192
VB	4949
VB	4950
VB	2189
VB	2190
VB	4967
VB	4968
VB	4201
VB	4202
VB	4691
VB	4992
VB	4981
VB	4982
V	4993
VB	4967
VB	4968
VB	4971
VB	4972
VB	4857
VB	4858
VB	4981
VB	4982
VB	4985

11

V	4439
V	4449
V	4450
VB	4411
V	4428
V	4431
V	4481
V	4412
V	4483
V	4437
V	4438
V	4447
V	4376
VB	4331
VB	4335
V	4423
V	4424
V	4417
V	4418
V	4373
V	4391
V	4427
V	4441
V	4350
VB	4340
V	4361
H	4351
H	4352
V	4342
V	4367
V	4370
V	4355
V	4332

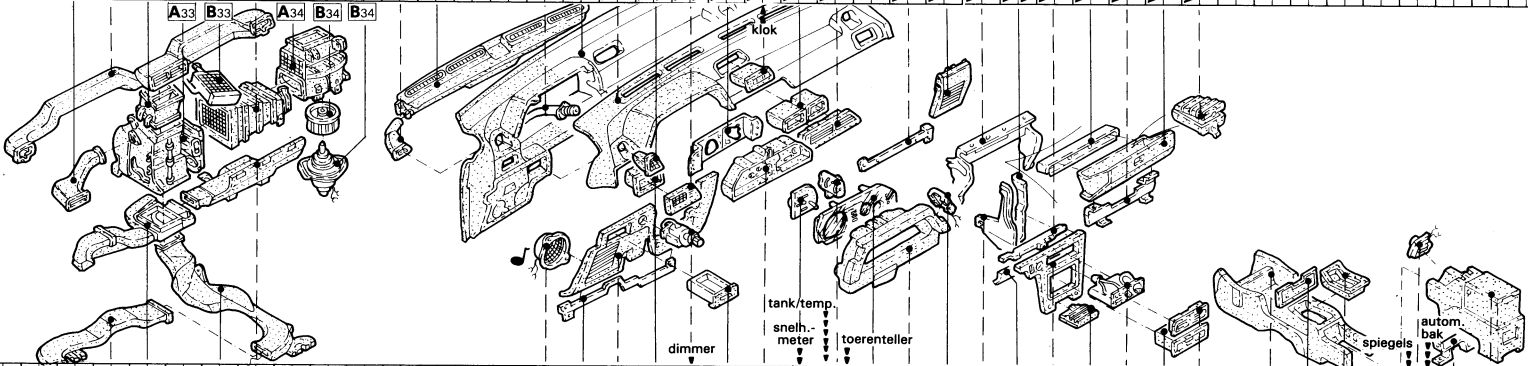

A33 B33 A34 B34 B34

dimmer
tank/temp.
snel.
meter
toerenteller

spiegels
autom.
bak

11

V	4435
V	4425
V	4436
V	4426
V	4393
V	4394
V	4356
VB	4339
V	4419
V	4420
V	4374
V	4345
V	4371
V	4375
V	4384
V	4397
V	4368
V	4343
V	4381
V	4382
H	4333
H	4334
V	4349
VB	4341
V	4359
V	4432
V	4396
V	4395
VB	4400
V	4402
V	4403
V	4372
V	4392
V	4408
VB	4401



Gebruikersnummer _____ • _____ Volg-nr. _____
Rapportnummer _____
Bezichtigingsdatum _____

© Copyright AUDATEX 1994

Nederland BV
audatex

19.05.89

AUDATEX Nederland BV
Handelsweg 6
Postbus 124
3700 AC Zeist

TEL: 03404/35800
FAX: 03404/15859

Algemene gegevens

Opmerkingen

Werkzaamheid _____
Polisnummer _____
Schadenummer _____
Schadedatum _____
Opdrachtdatum _____

Expertise-adres _____ (V/T/R/C)
Eigenaar _____ (V/T)
(V = VERZEKERDE / T = TEGENPARTIJ / R = REPARATEUR / C = CONTACTPERSOON)

Verzekerde
Naam _____
Straat/Nr. _____
PC/Plaats _____
Tel.nr./Land _____ N.L.
Vrije tekst _____

Tegenpartij
Naam _____
Straat _____
PC/Plaats _____
Tel.nr./Land _____ N.L.
Vrije tekst _____

Objectgegevens
Object _____
Merk _____
Model/Type _____
Kenteken/Land _____ N.L.
Chassisnummer _____
Cat.waarde _____ (incl. BTW)

Kleur _____
Soort brandst. _____
Afgifte deel 1 _____
Afgifte deel 2 _____
Bouwjaar 19_____
Toestand voert. _____ (1 = Goed 2 = Redelijk 3 = Matig 4 = Slecht 5 = zie opm.)
Km stand _____

Schadegegevens
Schade bev.zich. _____
Stootrichting _____ (00-12)
Aangrijppunt _____ (A t/m K)
Schade oorzaak _____ (A/B/D/H/S/V/W/O)
Eerdere schade _____ (-/J/N)
Reparatieduur _____ dagen
Gezien door expert _____ (J/N)

Polis-/Betaalgegevens
Verzek. bedrag _____
Dekking/Branche _____ 20_____
BTW-verrekenb. _____ (-/J/N)
Betaalgar./ber. _____ (-/J/N)
Akte van cessie _____ (-/J/N)

Aangrijppunt/Stootrichting

Overige gegevens
Opdrachtgever _____
Correspondent _____
Telefoonnr. _____
Tussenpersoon _____
Erkenningsnr. _____

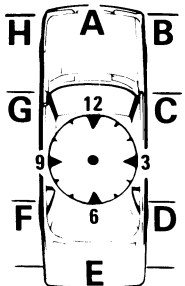

I boven zijde J onder zijde K totaal verlies

Reparateur/Contactpersoon
Naam _____
Straat _____
Nr./Toevoeging _____
PC/Plaats _____
Tel.nr./Land _____ N.L.

Akkoord *

Expert
Handtekening/
Stempel

Reparateur
Handtekening/
Stempel

audatex AEF-nr. G15

* betreft akkoord voor de vastlegging van de schade op dit formulier