

AEF-nr.	Fabrikant	Model
<b>Z19</b>	<b>Nissan</b>	<b>Sunny B12 Florida/Coupé 09/86-</b>

Nederland BV  
**audatex** 18.03.88  
© Copyright AUDATEX 1990

Eigenaar	
Kenteken	
Expert	



Type	Code X	Uitvoeringsspecificatie Code X	Uitvoeringsspecificatie Code X	Uitvoeringsspecificatie Code X	Uitvoeringsspecificatie Code X
Sunny LX	Florida	Z19 07	▼	▼ velgen staal	
Sunny LXD	Florida	Z19 05	D 1	5 J x 13	S 1
Sunny SLX	Florida	Z19 01	D 2	5 1/2 J x 14	S 2
Sunny SL	Florida	Z19 11	D 3		
			▼	▼ velgen lichtmetaal	
Sunny SLX	Coupé	Z19 03	V 6	5 J x 13	S 3
Sunny GTi 16V	Coupé	Z19 04	I 2	5 1/2 J x 14	S 4
Sunny SGX	Coupé	Z19 06	H 1		
			H 2	▼ banden	
			H 3	155 SR 13	R 8
			G 6	175/70 R 13..S	R 1
			G 1	185/60 R 14..H	R 2
			G 3	185/60 R 14..V	R 4
			F 1	airconditioning	
				▼ lak	
				2-K-acryl (unie) rep.-lak	Y 2
			W 1	2-lagen-metallic	Y 4
			W 6	2-lagen-mica	Z 7
			X 7	spuiten deel in uitgeb. toestand	Y 8
			X 1	voersp. uitgeb. afsp. gemonteerd	Y 7
			X 4	2-lagen-uni	Z 8
				2-kleuren spuitwerk	Y 9
				▼ carburateurmotor	
				1,6 ltr. 62 kW E16S	N 9
				1,6 ltr. 69 kW GA16S	M 3
				▼ inspuitmotor	
				1,6 ltr. 54 kW E16I	N 1
				1,6 ltr. 66 kW GA16I	N 7
				1,6 ltr. 81 kW CA16D	N 2
				1,8 ltr. 92 kW CA18D	N 6
				▼ dieselmotor	
				1,7 ltr. 40 kW CD17	N 3
				▼ katalysator	
				katalysator geregeld	V 1
				▼ wisselbak	
				5-versnellingen	P 3
				▼ stuurbekrachtiging	
					Q 1

Tarieven			
Arbeidstarief per AE		Spuittarief per AE	
			Excl. materiaal Incl. materiaal

Tekstzone codes				
Onderdelen*				
Arbeidsloon*				
Spuitloon*				
Spuitmateriaal		45	fl/dm <sup>2</sup>	51
Anti - roest	70	fl	Kleinmateriaal	27 fl
behandeling	71	fl	**	Aftrek 1 <sup>e</sup> schade 95 fl
Uitlijnen	74	fl	Begr. kosten rep.	90 fl
Hulpstoffen	63	fl	Poetsen/reinigen	67 fl

Bewerking	Benaming		▼AE	%	Bedrag
V	0731	Gloeilampen (VM)			fl
B	9950 <sub>3</sub>	Richtbankbedrag (HM)			fl
B	9952 <sub>3</sub>	Richtbank aanpassen + vtg. op en af			
H	0245 <sub>3</sub>	Richten voorzijde			
H	2695 <sub>3</sub>	Richten achterzijde			
H	1477 <sub>3</sub>	Richten zijkant L.			
H	1478 <sub>3</sub>	Richten zijkant R.			
B	0247 <sub>3</sub>	Dé-/montage t.b.v. spuitwerk			
B	9951	Dé-/montage delen LPG-installatie			
V	9987	Koelvloeistof (VM)			fl
V	B 0734	Antenne (VM)			fl
V	B 2709	Trekhaak (VM)			fl
***	Vrije deel				
					fl
					fl
					fl
					fl
					fl
R	Risico				fl
$\downarrow$ aant. - X - + aant. - X - zones = Totaal aant. - X -					

Fantoom	Uitvoeringsspecificaties	Speciaal rapport	
Merk		Resultatenblad	1
		Controleblad	1 2
Model		Oude prijs	A
		Prijdatum	
Type		Tekst kort	1 Lang 2
		Geen spuitw.	L

* Voor codes zie "Audatex-codekaart" <input type="checkbox"/> Alleen i.c.m. AZT		
** Alleen te gebruiken bij vervanging carrosserie		
*** Naar keuze invullen V,GV,B,H,GH,C,SV,SH,S of O		
Serie: 2	Wijzigingsdatum 23.11.90	(240890)
<b>Nissan</b>	<b>Sunny B12</b>	<b>Z19</b>



3

Coupé

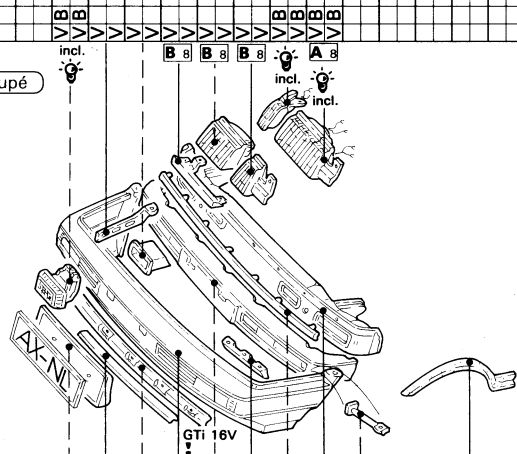

Achterruit rep.-set (verwarm.)

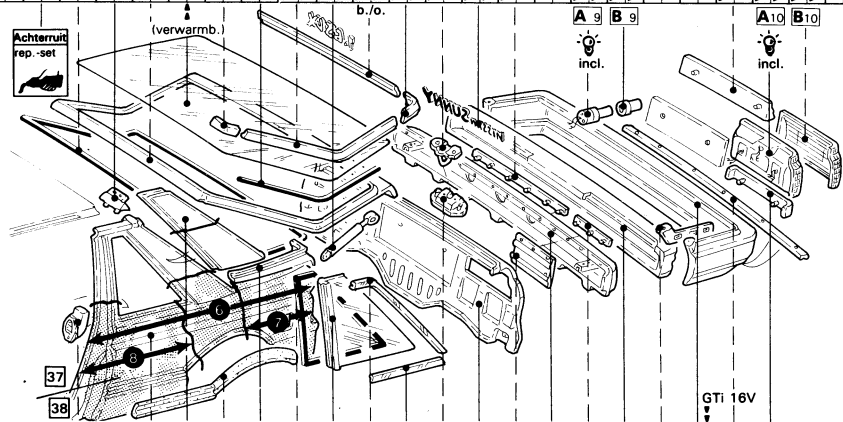

Gedeeltelijk S/H

3

V	0260	
V	0349	
V	0346	
V	0283 S	
V	0283 S	
V	0315	
V	0347	
V	0348	
V	0345	
V/B	H0340	
V	H0319	
V	H0320	
V/B	0783 S	
V/B	0784 S	

V/B	3891	
V/B	3892	
V	H3481 S	
V	H3482 S	
V	H2325 S	
V	H2326 S	
V/B	3613	
V/B	3614	
V	H3571 S	
V	H3572 S	
V	3819	
V	3820	
V/B	3803	
V/B	3804	
V/B	2437	
V/B	2438	
V/B	3831	
V/B	3832	
V	2977	
V	H2711 S	
V	2645	
V	2646	
V/B	H2640	
V	2647	
V	2648	
V	2585	
V	2621	
V	2622	
V	2583 S	
V	2583 S	
V	2584	
V/B	2763 S	
V/B	2764 S	

GH	3531 S	
GH	3532 S	
GH	3533 S	
GH	3538 S	
GH	3541 S	
GH	3542 S	
GH	3559	
GH	3560	

Gedeeltelijk V/H

\* Audatex - D-  
6 \* 7 \* 8 \*

4

Ruitbediening elektrisch Coupé SGX

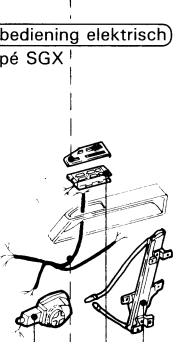

Voor

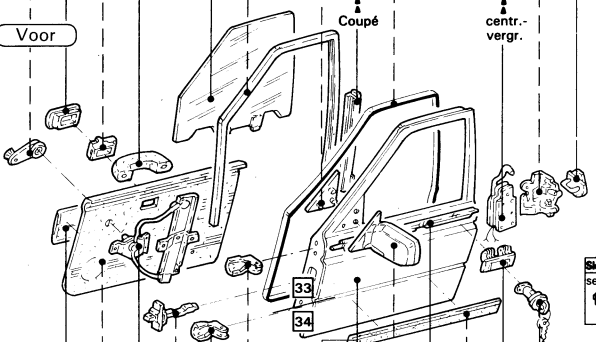

Achter

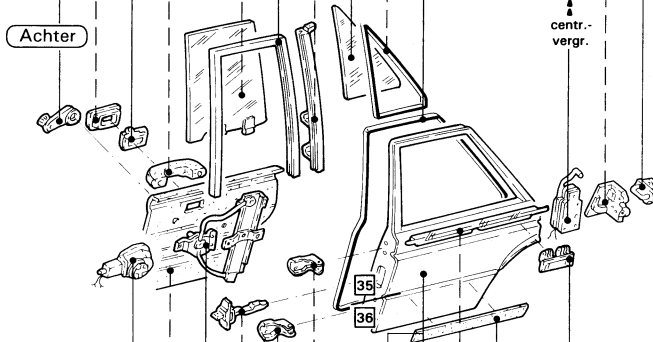

Gedeeltelijk S/H

4

V	1551	
V	1552	
C	H9611	
V	H9612	
V	1767	
V	1771	
V/B	1547	
V/B	1548	
V	1735	
V/B	1736	
V	1711	
V/B	1712	
V/B	1548	
V/B	1548	
V	1505	
V	1506	
V	H1495	
V	H1496	
V	H1487	
V	H1488	
V	1485	
V	1486	
V	H1481 S	
V/B	H1482 S	
V/B	H1482 S	
V/B	1737 S	
V/B	1738 S	
V/B	1661	
V/B	1662	
V/B	1681	
V/B	1682	
V/B	1565	
V/B	1566	
V/B	1569	
V/B	1570	
V	1779	

V	1875	
V	1876	
V	1873	
V	1874	
V	1871	
V	1872	
V	2031	
V	2032	
V/B	1819	
V/B	1820	
V	1897	
V	1898	
V	1898	
V	1893	
V	1894	
V/B	1829	
V/B	1830	
V	1835	
V	1836	
V	1809	
V	1810	
V	1887	
V	1888	
V	1877	
V	1878	
V	1881	
V	1882	

C	1851	
V	1852	
V/B	2011	
V/B	2012	
V/B	1847	
V/B	1848	
V	1805	
V	1806	
V	H1795	
V	H1796	
V	H1787	
V	H1788	
V	1785	
V/B	H1781 S	
V/B	H1782 S	
V/B	1961	
V/B	1962	
V	1981	
V	1982	
V/B	1865	
V/B	1866	

GH	1753 S	
GH	1754 S	
GH	1751 S	
GH	1752 S	
GH	2053 S	
GH	2054 S	
GH	2051 S	
GH	2052 S	

aant.-X

aant.-X

aant.-X

aant.-X





10

aant.-X

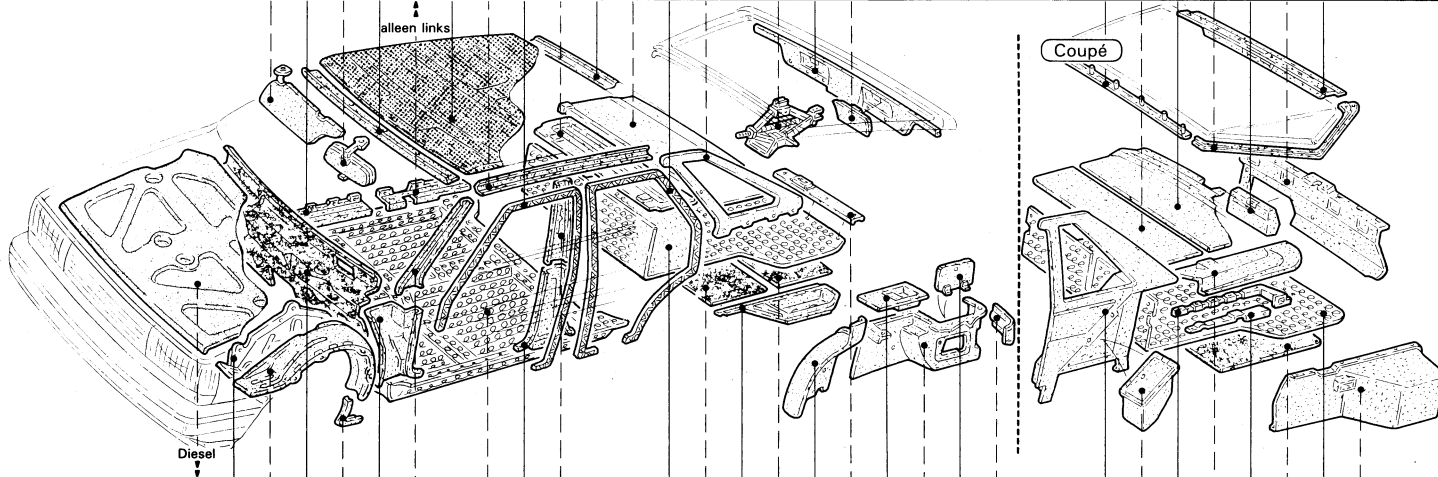

V	4933
V	4934
V	4897
V	4898
V	4931
V	4965
V	4899
V	4957
V	4963
V	4964
V	1777
V	1778
V	4851
V	4966
V	4852
V	2063
V	2064
V	3867
V	3888
V	4999
V	4907
V	4909
V	4910

V	4908
V	4851
V	4852
V	4909
V	4910
V	4986
V	4985
V	4907

10

aant.-X

V	0481
V	0833
V	0834
V	0841
V	0842
V	1322
V	0843
V	0844
V	4939
V	4940
V	4941
V	4942
V	4873
V	4949
V	4950
V	4951
V	4952
V	4978
V	4979
V	4995
V	4996
V	4980
V	4983
V	4984
V	4987
V	4988
V	4861
V	4862
V	4981
V	4982
V	4986
V	3307
V	3308
V	4901
V	4902
V	4903
V	4904
V	4863
V	4864
V	4853
V	4854
V	4865
V	4866
V	4979
V	4978
V	4981
V	4982

11

aant.-X

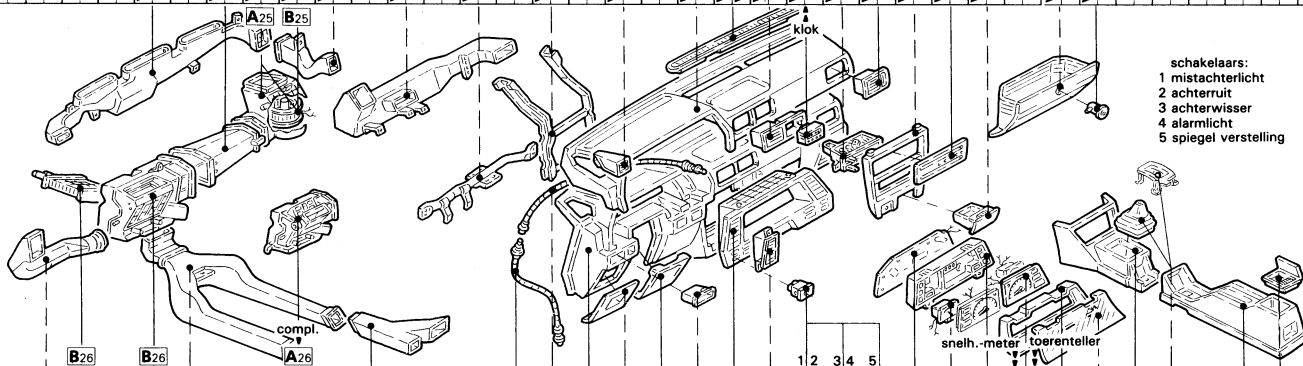

- schakelaars:
- 1 mistachterlicht
  - 2 achterruijt
  - 3 achterwisser
  - 4 alarmlicht
  - 5 spiegel verstelling

V	4437
V	4428
V	4413
V	4441
V	4411
V	4445
V	4446
V	4374
V	4376
V	4331
V	4349
V	4350
V	4342
V	4341
V	4423
V	4425
V	4393
V	4392
V	4394
V	4395
V	4396
V	4373
V	4383
V	4384
V	4371
V	4375
V	4397
V	4369
V	4368
V	4399
V	8993
V	4400
V	4408

audatex AEF nr. Z19

- Units uit + in/O + S/C  
 - Uittijnen afstellen  
 Let op, zone 9





V	8851
V	8979
V	8864
V	8941
V	8863
V	8935
V	C 8501
V	8872
V	8999
V	8997
V	9003
V	8995
V	9005

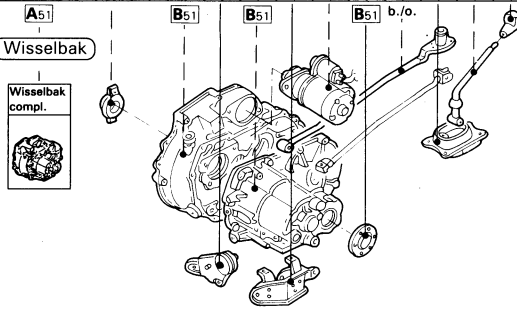

V	79002
V	79102
V	79312
V	79332
V	82812
V	82832
V	8632
V	8635
V	8623
V	7855
V	8417
V	8425
V	C 8411
V	8428
V	80082
V	80072
V	80162
V	80232
V	80212
V	83112
V	8252
V	80092
V	80102
V	83012
V	79612
V	79412
V	83312
V	83512
V	7880
V	7876
V	78792
V	80372
V	80412
V	8806
V	8241
V	8388
V	8395
V	8391
V	8191
V	8147

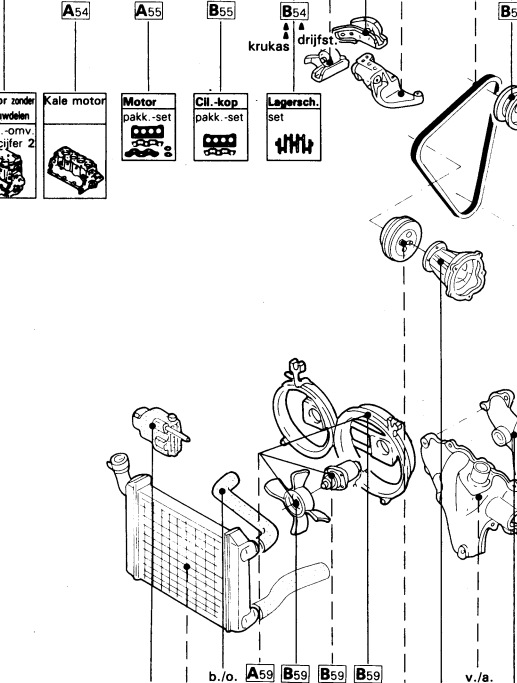

V	7787
V	BCH 7761
V	7776
V	7773
V	7789
V	7793
V	7790
V	H 7767
V	7831
V	C 7813
V	8804
V	8805
V	8801
V	8807
V	8809
V	79912
V	8661
V	8665
V	8657
V	8679
V	82662
V	8620
V	82632
V	82542
V	80652
V	8622
V	7833
V	8265
V	8970
V	8975
V	8971
V	8457
V	C 8451
V	80512
V	8467
V	8677
V	8674
V	8774
V	8779
V	8221
V	8778
V	4087
V	4088

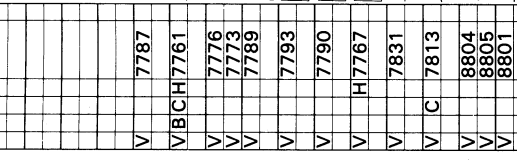







20

aant.-X.

20

aant.-X.

21

aant.-X.

**Stuurbekrachtiging**

GTi 16V  
US = Q1

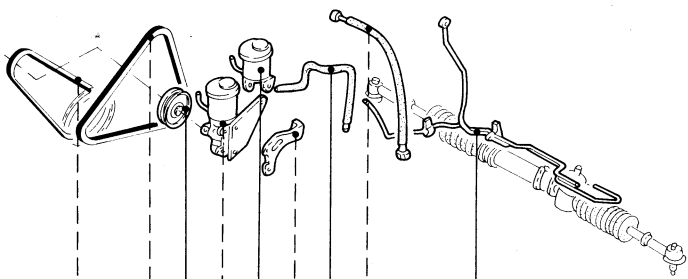

B75 A75 B75

**Schijfremmen achter**

GTi 16V

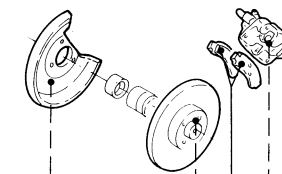

set

21

aant.-X.

V	7477	V	7855	V	7473	V	C	7461	V	7479	V	7472	V	7488	V	7487	V	7491
---	------	---	------	---	------	---	---	------	---	------	---	------	---	------	---	------	---	------

V	9157	V	9158	V	C	9191	V	C	9192	V	9179	V	9159	V	9160
---	------	---	------	---	---	------	---	---	------	---	------	---	------	---	------

Gebuikersnummer \_\_\_\_\_ • \_\_\_\_\_ Volg-nr. \_\_\_\_\_  
Rapportnummer \_\_\_\_\_  
Bezichtingsdatum \_\_\_\_\_

AUDATEX Nederland BV  
Huis ter Heideweg 16  
Postbus 124  
3700 AC Zeist  
TEL: 03404/12510  
FAX: 03404/15859

**Algemene gegevens**

**Opmerkingen**

Polisnummer \_\_\_\_\_  
Schadenummer \_\_\_\_\_  
Schadedatum \_\_\_\_\_  
Opdracht datum \_\_\_\_\_

Eigenaar \_\_\_\_\_ (V/T)  
(V = VERZEKERDE/ T = TEGENPARTIJ)

**Verzeerde**  
Naam \_\_\_\_\_  
Straat/Nr. \_\_\_\_\_  
PC/Plaats \_\_\_\_\_  
Tel.nr./Land \_\_\_\_\_ N.L.

**Tegenpartij**  
Naam \_\_\_\_\_  
Straat \_\_\_\_\_  
PC/Plaats \_\_\_\_\_  
Tel.nr./Land \_\_\_\_\_ N.L.

**Objectgegevens**  
Object \_\_\_\_\_  
Merk \_\_\_\_\_  
Model/Type \_\_\_\_\_  
Kenteken/Land \_\_\_\_\_ N.L.  
Chassisnummer \_\_\_\_\_  
Cat.waarde \_\_\_\_\_ (incl. BTW)

Kleur \_\_\_\_\_  
Bouwjaar 19\_\_\_\_\_  
Afgifte deel 1 \_\_\_\_\_  
Afgifte deel 2 \_\_\_\_\_  
Toestand voert. \_\_\_\_\_ (1 = Goed 2 = Redelijk 3 = Matig 4 = Slecht 5 = zie opm.)  
Km stand \_\_\_\_\_

**Schadegegevens**  
Schade bev.zich \_\_\_\_\_  
Stootrichting \_\_\_\_\_ (00-12)  
Aangrijppunt \_\_\_\_\_ (A t/m K)  
Eerdere schade \_\_\_\_\_ (J/N/O)  
Reparatieduur \_\_\_\_\_ dagen

**Polis-/Betaalgegevens**  
Verzek. bedrag \_\_\_\_\_  
Dekking/Branche \_\_\_\_\_ 20  
BTW-verrekenb. \_\_\_\_\_ (J/N/O)  
Betaalgar./ber. \_\_\_\_\_ (J/N)  
Akte van cessie \_\_\_\_\_ (J/N/O)

Schade oorzaak \_\_\_\_\_ (A/B/D/H/S/V/W/O)  
**Aangrijppunt/Stootrichting**

**Overige gegevens**  
Opdrachtgever \_\_\_\_\_  
Correspondent \_\_\_\_\_  
Telefoonnr. \_\_\_\_\_  
Tussenpersoon \_\_\_\_\_  
Kopie AUDABOX \_\_\_\_\_ • \_\_\_\_\_

**Reparateur/Contactpersoon**  
Naam \_\_\_\_\_  
Straat \_\_\_\_\_  
Nr./Toevoeging \_\_\_\_\_  
PC/Plaats \_\_\_\_\_  
Tel.nr./Land \_\_\_\_\_ N.L.  
Erkenningsnr. \_\_\_\_\_

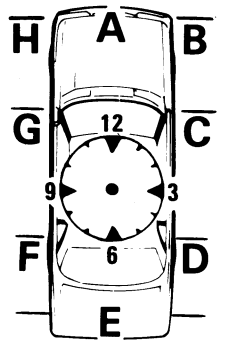

Table with multiple empty rows for 'Opmerkingen' (Remarks).

**Akkoord \***

**Expert**  
Handtekening/  
Stempel

**Reparateur**  
Handtekening/  
Stempel

\* betreft akkoord voor de vastlegging van de schade op dit formulier