

10

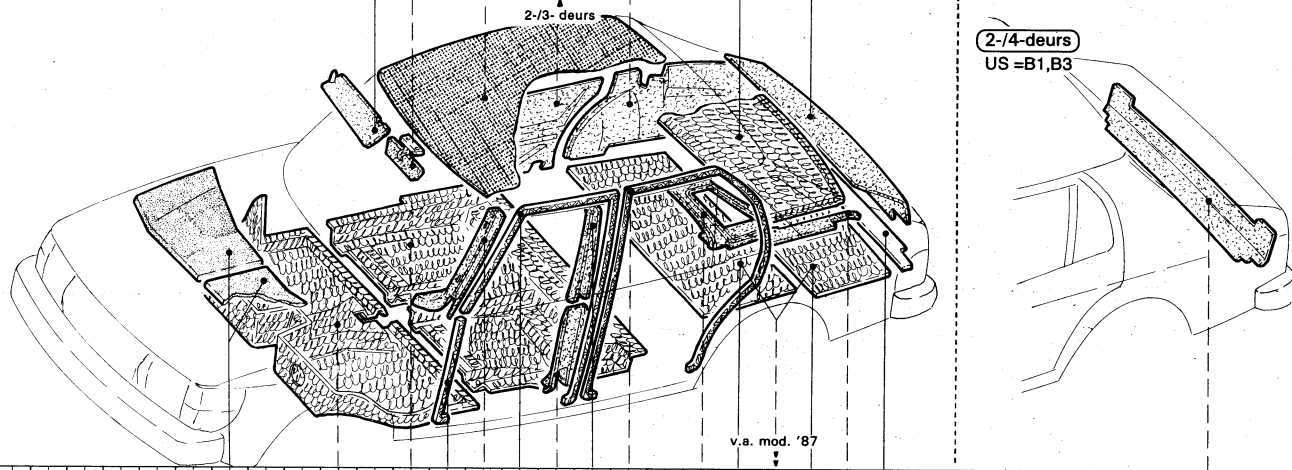

V	4933
V	4934
V	4931
V	4957
V	4901
V	4902
V	4981
V	4982
V	4927
V	3047

10

V	0481
V	4889
V	4890
V	1775
V	1776
V	4941
V	4942
V	1777
V	1778
V	4949
V	4950
V	4951
V	4952
V	2063
V	2064
V	4971
V	4972
V	4961
V	4860
V	4862
V	4855
V	4856
V	4863
V	4985

11

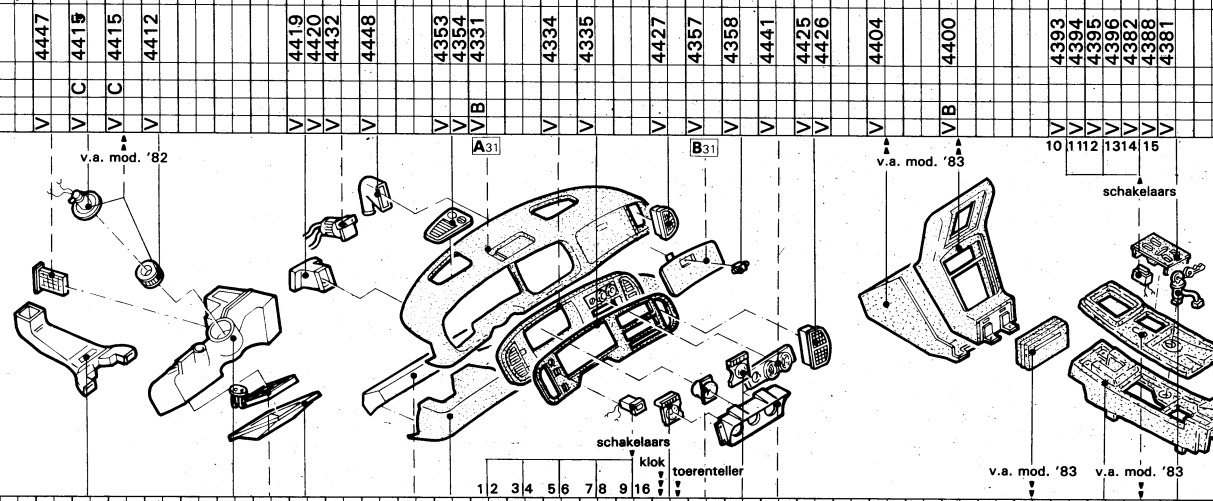

V	4447
V	4419
V	4415
V	4412
V	4419
V	4420
V	4432
V	4448
V	4353
V	4354
V	4331
V	4334
V	4355
V	4427
V	4367
V	4358
V	4441
V	4425
V	4426
V	4404
V	4400
V	4393
V	4394
V	4395
V	4396
V	4382
V	4368
V	4381

- schakelaars:
- 1 verlichting
 - 2 stoelverwarming
 - 3 buitenspiegel l.
 - 4 buitenspiegel r.
 - 5 mistachterlicht
 - 6 alarmlicht
 - 7 luchtrecirculatie
 - 8 achterruit
 - 9 air-conditioning
 - 10 ruitbediening v.l.
 - 11 ruitbediening v.r.
 - 12 ruitbediening a.l.
 - 13 ruitbediening a.r.
 - 14 veiligheids-schakelaar
 - 15 schuifdak
 - 16 ventilator

schakelaars
 klok
 toerenteller
 1 2 3 4 5 6 7 8 9 16

11

V	4446
V	4413
V	4428
V	4445
V	4431
V	4349
V	4332
V	4333
V	4351
V	4352
V	4336
V	4342
V	4350
V	4372
V	4374
V	4391
V	4397
V	4375
V	4384
V	4371
V	4407
V	4408
V	4405
V	4409

16

V	8138
V	8149
V	8142
V	8135
V	8136
V	8581

V	8301
V	8302
V	8149
V	8175
V	8177

V	8722
V	8801
V	8725
V	8149
V	8138
V	8142
V	8135
V	8136
V	8581

V	8722
V	8801
V	8301
V	8302
V	8175
V	8177

Inspuiting 2,0 ltr
B 201 i US =N3,N7

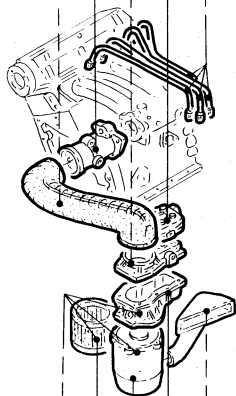

tot mod. '84 v.a. mod. '85
A57 B57

Inspuiting 2,0/2,1 ltr. (16 V)
B 202 i US =O1,O2,O4
B 212 i US =O3

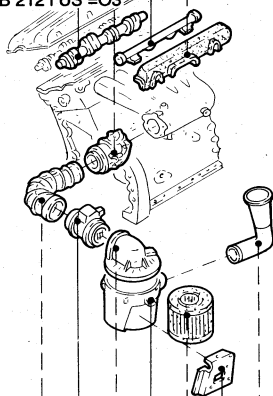

Koeling 2,0 ltr. Turbo
B 201 T US =N4,N6,N8
B 202 T US =N5,N9,O5

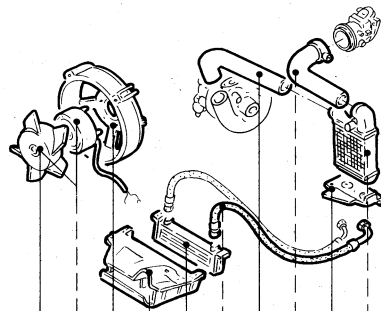

B58 A58

Inspuiting 2,0 ltr. (Turbo)
B 201 T US =N4,N6,N8

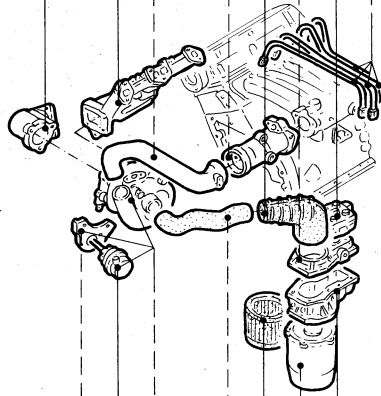

tot mod. '86 RD
B59 B59 A59

Inspuiting 2,0 ltr. (Turbo 16 V)
B 202 T US =N5,N9,O5

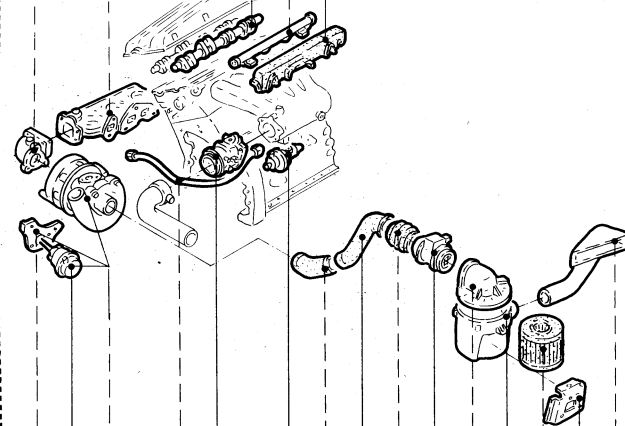

tot mod. '86 RD
B60 B60 A60

16

V	8391
V	8395
V	8402
V	8143
V	8403

V	8407
V	8142
V	8401
V	8402
V	8395
V	8397
V	8403

V	7793
V	7790
V	7796
V	7777
V	7779
V	7781
V	7782
V	8725
V	8727
V	8732
V	8730

V	8735
V	8733
V	8720
V	8721
V	8727
V	8395
V	8402
V	8143

V	8735
V	8733
V	8720
V	8721
V	8168
V	8149
V	8167
V	8409
V	8408
V	8407
V	8142
V	8401
V	8402
V	8395
V	8397
V	8403

17

Airconditioning
US =F1,F2

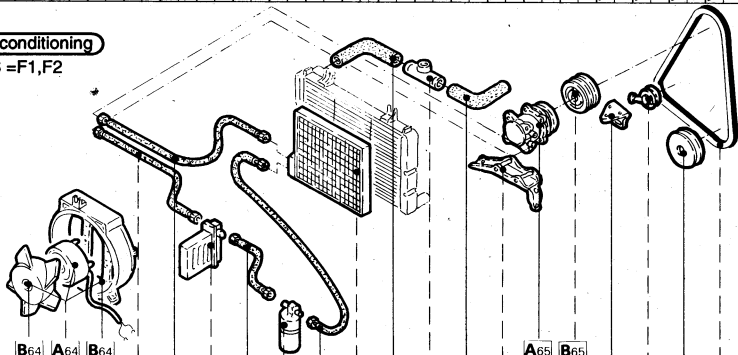

B64 A64 B64

Airconditioning
Sankyo/Sanden
US =F2

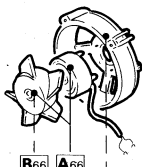

B66 A66

V	4487
V	4488
V	4486
V	4484
V	4481
V	4485
V	4483
V	4467
V	4482
V	4465
V	7783
V	7789
V	7784
V	4457
V	4455
V	4461
V	4464
V	4463
V	8274
V	4459
V	4487
V	4488
V	4486

V	4487
V	4488
V	4486
V	4484
V	4481
V	4485
V	4483
V	4467
V	4482
V	4465
V	7783
V	7789
V	7784
V	4457
V	4455
V	4461
V	4464
V	4463
V	8274
V	4459
V	4487
V	4488
V	4486

V	4487
V	4488
V	4486
V	4484
V	4481
V	4485
V	4483
V	4467
V	4482
V	4465
V	7783
V	7789
V	7784
V	4457
V	4455
V	4461
V	4464
V	4463
V	8274
V	4459
V	4487
V	4488
V	4486

aant.-X-

aant.-X-

aant.-X-

20

Velgen-design

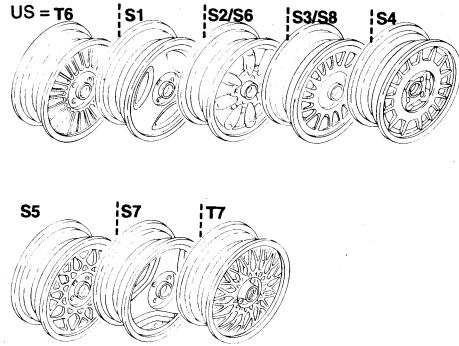

aant.-X

20

21

Stuurbekrachtiging
US = Q1

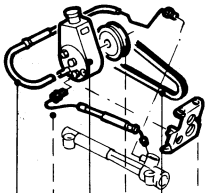

Stuurbekrachtiging
Inspuiting (16 V) US = Q1O1,
Q1O2, Q1O3, Q1O4
Turbo (16 V) US = Q1N5, Q1N9, Q1O5

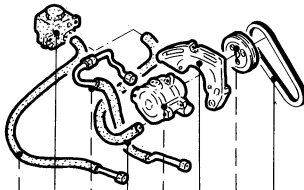

Stabilisator voor
Turbo 16 S

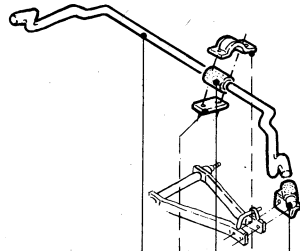

Antiblokkeersysteem
US = Q7

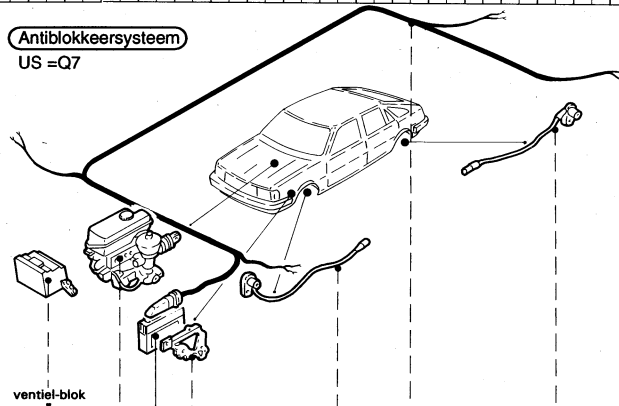

Airbag bestuurder
US = Q8

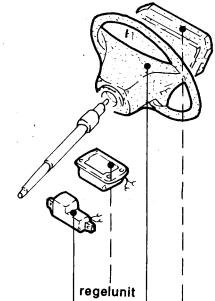

21

V	7485
V	7487
V	7461
V	C 7473
V	7477
V	7469

V	7485
V	7479
V	7487
V	7489
V	C 7461
V	7469
V	7473
V	7477

V	7261
V	7273
V	7274
V	7269
V	7270
V	7267
V	7268
V	7271
V	7272

V	7243
V	C 7241
V	B 7259
V	7263

V	7245
V	7246
V	H9583

V	7247
V	7248

V	7445
V	7446
V	7440
V	7400
V	7411

aant.-X

Gebruikersnummer _____ • _____ Volg-nr. _____
Rapportnummer _____
Bezichtigingsdatum _____

Nederland BV
audatex

18.03.88

© Copyright AUDATEX 1993

AUDATEX Nederland BV
Handelsweg 6
Postbus 124
3700 AC Zeist

TEL: 03404/35800
FAX: 03404/15859

Algemene gegevens

Opmerkingen

Werkzaamheid _____
Polisnummer _____
Schadenummer _____
Schadedatum _____
Opdrachtdatum _____

Expertise-adres _____ (V/T/R/C)
Eigenaar _____ (V/T)
(V = VERZEKERDE / T = TEGENPARTIJ / R = REPARATEUR / C = CONTACTPERSOON)

Verzekerde
Naam _____
Straat/Nr. _____
PC/Plaats _____
Tel.nr./Land _____ N.L.
Vrije tekst _____

Tegenpartij
Naam _____
Straat _____
PC/Plaats _____
Tel.nr./Land _____ N.L.
Vrije tekst _____

Objectgegevens
Object _____
Merk _____
Model/Type _____
Kenteken/Land _____ N.L.
Chassisnummer _____
Cat.waarde _____ (incl. BTW)

Kleur _____
Afgifte deel 1 _____
Afgifte deel 2 _____
Bouwjaar 1,9 _____
Toestand voert. _____ (1 = Goed 2 = Redelijk 3 = Matig 4 = Slecht 5 = zie opm.)
Km stand _____

Schadegegevens
Schade bev.zich. _____
Stootrichting _____ (00-12)
Aangrijppunt _____ (A t/m K)
Schade oorzaak _____ (A/B/D/H/S/V/W/O)
Eerdere schade _____ (-/J/N)
Reparatieduur _____ dagen
Gezien door expert _____ (J/N)

Polis-/Betaalgegevens
Verzek. bedrag _____
Dekking/Branche _____ 2,0
BTW-verrekenb. _____ (-/J/N)
Betaalgar./ber. _____ (-/J/N)
Akte van cessie _____ (-/J/N)

Aangrijppunt/Stootrichting

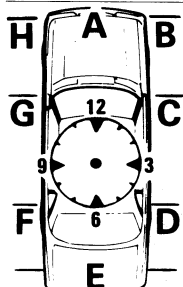

I boven zijde J onder zijde K totaal verlies

Overige gegevens
Opdrachtgever _____
Correspondent _____
Telefoonnr. _____
Tussenpersoon _____
Erkenningsnr. _____

Reparateur/Contactpersoon
Naam _____
Straat _____
Nr./Toevoeging _____
PC/Plaats _____
Tel.nr./Land _____ N.L.

Akkoord *

Expert
Handtekening/
Stempel

Reparateur
Handtekening/
Stempel

audatex AEF-nr. JO1

* betreft akkoord voor de vastlegging van de schade op dit formulier