

AEF-nr.	Fabrikant	Model	Arisco bv audatex © Copyright AUDATEX 1996				Eigenaar	SUBARU			
X04	Subaru	Legacy Sedan [BC1] 11/89-04/94	22.05.92				Kenteken				
Type Code X						Tarieven					
STANDAARD INVOERGEDEVENS		OPTIONELE INVOERGEDEVENS		▼ banden		Arbeidsloon per AE		Spuitsloot per AE		Excl. materiaal Incl. materiaal	
Legacy 1800 DL	2WD	X04 23	▼	165	R 13	R 1					
Legacy 1800 GL	2WD	X04 22	glasschuif-/hefdak elektrisch	C 2	175/70	R 14	R 2				
Legacy 2000 GL	2WD	X04 24	▼	185/70	R 14	R 3					
Legacy 1800 GL	4WD	X04 01	buitenspiegels elektrisch	G 6	195/65	R 14	R 5				
Legacy 2000 GL	4WD	X04 08	buitenspiegels elektr./verwarmb.	G 9	205/60	R 15	R 4				
Legacy 2200 GX	4WD	X04 02	autom. antenne op a. scherm	H 9							
Legacy 2000 Turbo	4WD	X04 09	▼								
			spatlappen voor	T 1							
			spatlappen achter	T 2							
			▼								
			koplampreinigingsinstallatie	I 6							
			mistlampen	I 3							
			▼								
			airconditioning	F 1							
			▼								
			koplamphoogteregeling	I 7							
			centrale vergrendeling	G 1							
			centr.-vergr. infrarood	H 3							
			portierslot met codering								
			Key-Less entry	G 5							
			ruitbediening v./a. elektr.	G 2							
			▼								
			stoelhoogteverstelling	J 8							
			stoelen voor verwarmbaar	J 7							
			stuurwiel leer	M 1							
			▼								
			antiblokkeersysteem Subaru	Q 7							
			antiblokkeersysteem BOSCH	T 7							
			schijfremmen achter	K 6							
			stabilisator achter	T 3							
			▼								
			▼ velgen								
			5 J x 13	S 1							
			5 J x 14	S 2							
			5,5 J x 14	S 4							
			5,5 J x 14 lichtmetaal	S 5							
			6 J x 14 lichtmetaal	S 7							
			6 J x 15 lichtmetaal	S 6							
			wieldoppen	S 9							
			▼ spuitmethode								
			spuiten deel in uitgeb. toestand	Y 8							
			voersp. uitgeb. afsp. gemonteerd	Y 7							
			2 kleuren spuiten	Y 9							
Fantoom			Uitvoeringsspecificaties				Speciaal rapport				
Merk							Resultatenblad 1				
Model							Controleblad 1 2				
Type							Prijedatum				
							Tekst kort 1 Lang 2				
							Geen spuitw. L				
							R Risico				
							aant. - X + aant. - X - zones = Totaal aant. - X -				
							* Voor codes zie "Audatex-codekaart" 1) positie 4/5 v/h chassisnummer				
							** Alleen te gebruiken bij vervanging carrosserie 2) positie 7 v/h chassisnummer				
							*** Naar keuze invullen V,GV,B,H,GH,C,SV,SH,S of O				
							Serie: 2		Wijzigingsdatum 19.09.96		(201295)
							Subaru		Legacy [BC1]		X04

5

V	H1169	S
V	H1170	S
V	H1167	S
V	H1168	S
V	H1123	S
V	H1124	S
V	H1129	S
V	H1130	S
V	H1321	S
V	H1352	S
V	H1351	S
V	H1337	S
V	H4265	S
V	H2385	S
V	H2386	S
V	H2263	S
V	H2264	S
V	H2387	S
V	H2391	S
V	H2399	S
V	H2400	S
V	H4252	S
V	H2389	S
V	H4285	S
V	H3901	S

V/B	H4080	S
V	4078	S
V	4077	S
V	4087	S
V	4088	S
V	4089	S
V	4093	S
V	4094	S
V	4073	S
V	4066	S
V	4065	S

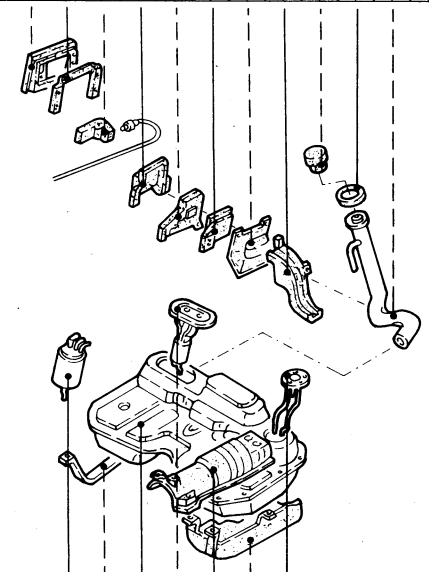
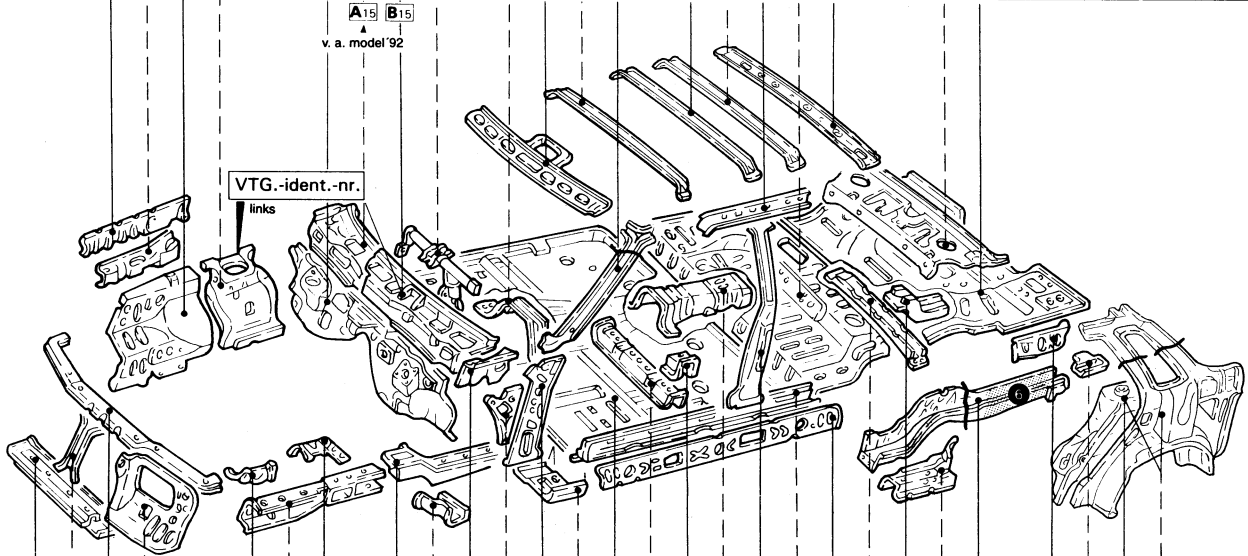

5

V	H1001	S
V	H0988	S
V	H1017	S
V	H1187	S
V	H1188	S
V	H1211	S
V	H1212	S
V	H1207	S
V	H1208	S
V	H1209	S
V	H1210	S
V	H1213	S
V	H1214	S
V	H1285	S
V	H1286	S
V	H1357	S
V	H1358	S
V	H2271	S
V	H2272	S
V	H2247	S
V	H2248	S
V	H4271	S
V	H4272	S
V	H4251	S
V	H3927	S
V	H3928	S
V	H3926	S
V	H4255	S
V	H2315	S
V	H2316	S
V	H4279	S
V	H4280	S
V	H2211	S
V	H2212	S
V	H3967	S
V	H3968	S
V	H3923	S
V	H3924	S
V	H3991	S
V	H3992	S
V	H3951	S
V	H3952	S
V	H4001	S
V	H4002	S
V	H4156	S
V	H4160	S
V	H4101	S
V	H4102	S

V	4090	S
V	4091	S
V	4059	S
V	4060	S
V/B	4057	S
V	C 8131	S
V	4053	S
V	4051	S
V	4052	S
V	4085	S
V	4011	S
V	4012	S
V	4019	S
V	4020	S

Bescherming aandrijving

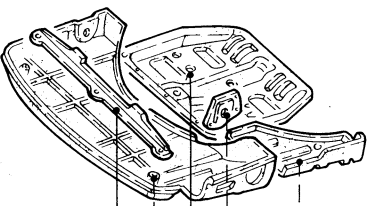

Frame

Schuifdak
US = C2

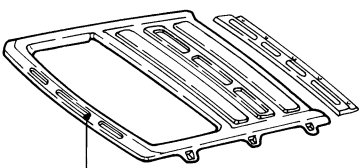

6

V	8784	S
V/B	8783	S
V/B	8780	S
V	8777	S
V	8778	S
V/B	8781	S
V/B	8782	S
V	H2386	S

10

VB	4933
VB	4934
VB	4931
VB	4957
VB	4941
VB	4942
VB	4965
VB	4966
V	4925
VB	4926
VB	4989
VB	4990
VB	4927
V	5000
V	4998
V	4999

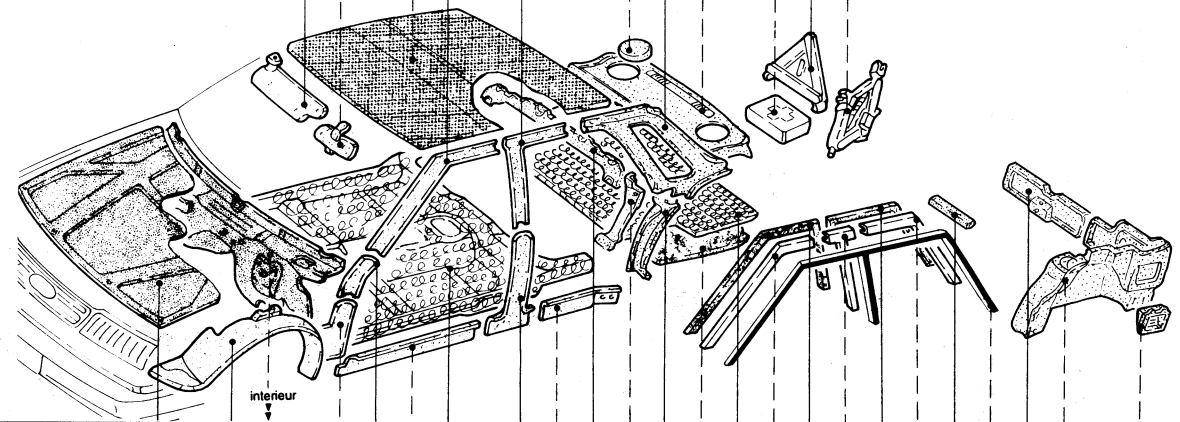

10

VB	0481
VB	0843
VB	0844
V	1322
VB	4939
VB	4940
VB	1675
VB	1676
VB	2173
VB	2174
VB	4873
VB	4949
VB	4950
VB	2177
VB	2178
V	4986
V	4983
VB	4984
VB	4967
VB	4968
V	4862
VB	4978
V	1521
V	1522
V	1777
V	1778
V	1515
V	1516
V	1825
V	1826
V	1813
V	1814
V	1827
V	1828
V	1517
V	1518
V	4985
VB	4981
VB	4982
VB	4447
VB	4448

11

V	4428
VB	4411
V	4416
VB	4415
V	4349
V	4423
V	4424
V	4337
V	4338
V	4345
V	4325
V	4326
V	4355
V	4340
V	4359
V	4361
V	4362
V	4347
V	4348
V	4432

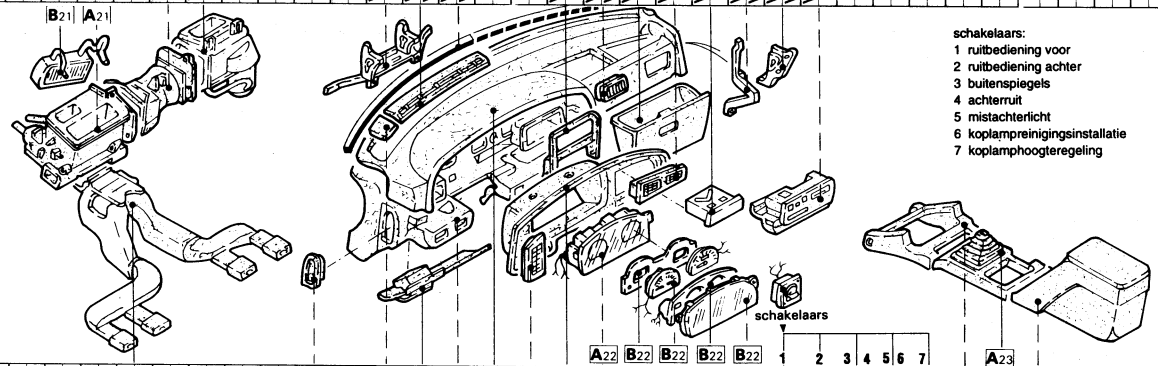

- schakelaars:
- 1 ruitbediening voor
 - 2 ruitbediening achter
 - 3 buitenspiegels
 - 4 achterruit
 - 5 mistachterlicht
 - 6 koplampreinigingsinstallatie
 - 7 koplamphoogteregeling

11

V	4449
V	4363
V	4364
V	4341
V	4342
V	4351
VB	4331
VB	4335
V	4339
V	4369
VB	4366
V	4373
V	4397
V	4375
V	4367
V	4368
V	5301
V	5302
V	5303
V	5304
V	5305
V	5306
V	5307
V	5308
V	5309
VB	4400
V	4871
VB	4401

16

V	8402
V	8395
V	8397
V	8401
V	8142
V	8143
V	8141 ₂
V	8400
V	8222
V	8149 ₂
V	8150 ₂
V	8223
V	8224
V	8225

2000/ 2200/ Turbo

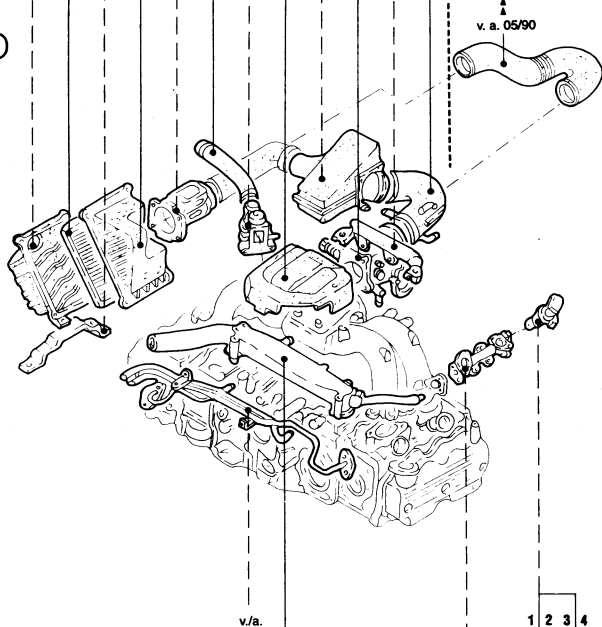

v.a. 1 2 3 4

V	8151 ₂
V	8152 ₂
V	7775 ₂
V	8153 ₂
V	8154 ₂
V	8551 ₂
V	8552 ₂
V	8553 ₂
V	8554 ₂

Turbo

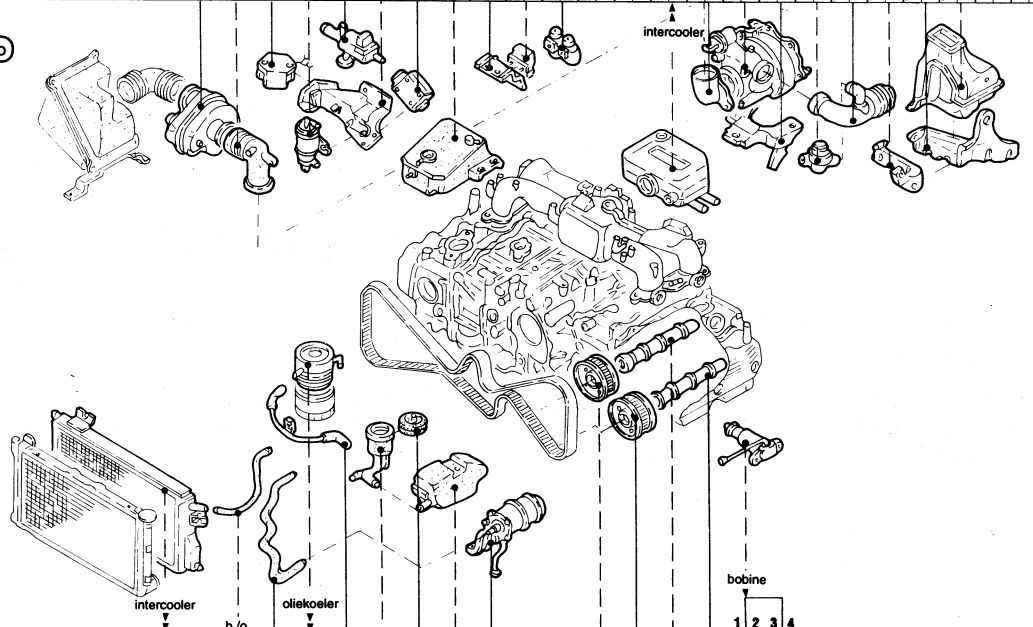

intercooler b.o. oliekoeler bobine 1 2 3 4

V	VBCH8761
V	8763
V	8764
V	8766
V	7779 ₂
V	7778 ₂
V	7788
V	7789
V	7787
V	C 8765
V	8311 ₂
V	8312 ₂
V	8309 ₂
V	8310 ₂
V	8301 ₂
V	8302 ₂
V	8303 ₂
V	8304 ₂
V	8465 ₂
V	8466 ₂
V	8467 ₂
V	8468 ₂

16

Airconditioning

US = F1

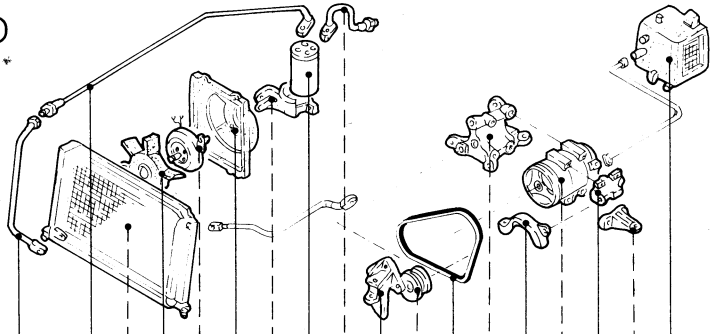

V	4481
V	4482
V	4483
V	4484
V	VBCH4465
V	4471
V	C 4472
V	4473
V	4468
V	4467
V	4485
V	4464
V	4463
V	4459
V	4457
V	4488
V	C 4455
V	4487
V	4458
V	C 4453

17

aant.-X

aant.-X

aant.-X

20

Antiblokkeersysteem
 US = Q7, T7

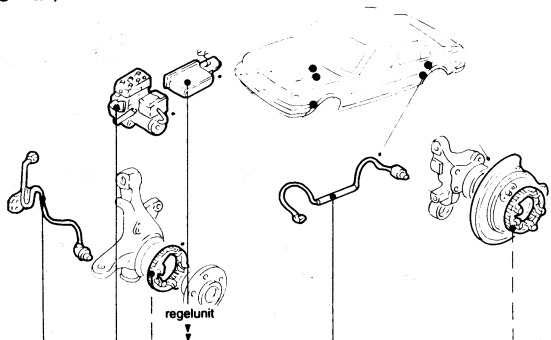

Schijfremmen achter
 US = K6

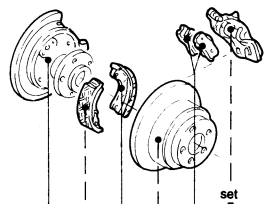

20

V	7245
V	7246
V	B.C. 7527
V	7119
V	7120
V	C 7259
V	7247
V	7248
V	9119
V	9120

V	9149
V	9150
V	9171
V	9172
V	9173
V	9174
V	9191
V	9192
V	9179
V	9159
V	9160

21

Stuurbechrachting

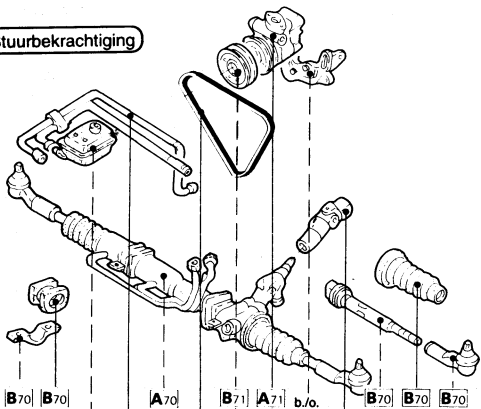

Turbo
 Koppelings- cilinder

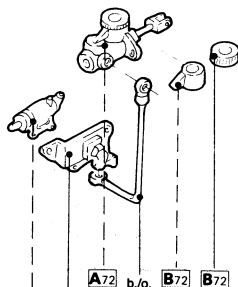

Achteras 2 WD

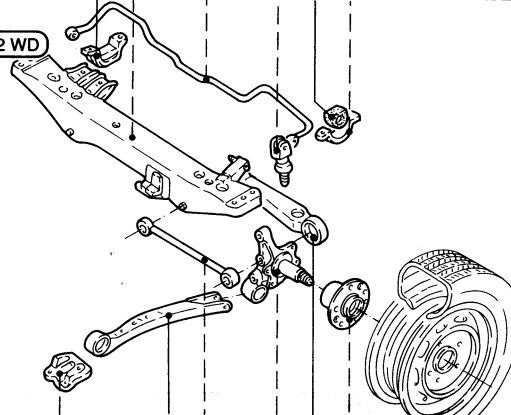

21

V	7315
V	7316
V	7317
V	7318
V	7479
V	7484
V	7300
V	7477
V	7473
V	C 7461
V	7466
V	7465
V	7373
V	7309
V	7310
V	7327
V	7328
V	7311
V	7312

V	8965
V	7543
V	C 7525
V	7541
V	7542
V	7526
V	7524

V	9383
V	9384
V	9379
V	9390
V	9377
V	9378
V	9305
V	9306
V	9385
V	9386
V	9181
V	9182



Gebruikersnummer • Volg-nr.
Rapportnummer
Bezichtigingsdatum

Arisco bv
audatex

22.05.92

© Copyright AUDATEX 1996

Arisco bv
Handelsweg 6
Postbus 124
3700 AC Zeist

TEL: 030/6935800
FAX: 030/6915859

Algemene gegevens

Opmerkingen

Werkzaamheid
Polisnummer
Schadenummer
Schadedatum
Opdrachtdatum

Expertise-adres (V/T/R/C)
Eigenaar (V/T)
(V = VERZEKERDE / T = TEGENPARTIJ / R = REPARATEUR / C = CONTACTPERSOON)

Verzekerde
Naam
Straat/Nr.
PC/Plaats
Tel.nr./Land N.L.
Vrije tekst

Tegenpartij
Naam
Straat
PC/Plaats
Tel.nr./Land N.L.
Vrije tekst

Objectgegevens
Object
Merk
Model/Type
Kenteken/Land N.L.
Chassisnummer
Cat.waarde (incl. BTW)

Kleur
Soort brandst.
Afgifte deel 1
Afgifte deel 2
Bouwjaar 19
Toestand voert. (1 = Goed 2 = Redelijk 3 = Matig 4 = Slecht 5 = zie opm.)
Km stand

Schadegegevens
Schade bev.zich.
Stootrichting (00-12)
Aangrijppunt (A t/m K)
Schade oorzaak (A/B/D/H/S/V/W/O)
Eerdere schade (-/J/N)
Reparatieduur dagen
Gezien door expert (J/N)

Polis-/Betaalgegevens
Verzek. bedrag
Dekking/Branche 2.0
BTW-verrekenb. (-/J/N)
Betaalgar./ber. (-/J/N)
Akte van cessie (-/J/N)

Overige gegevens
Opdrachtgever
Correspondent
Telefoonnr.
Tussenpersoon
Erkenningsnr.

Reparateur/Contactpersoon
Naam
Straat
Nr./Toevoeging
PC/Plaats
Tel.nr./Land N.L.

Aangrijppunt/Stootrichting

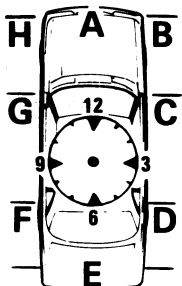

I boven zijde J onder zijde K totaal verlies

Akkoord*

Expert
Handtekening/
Stempel

Reparateur
Handtekening/
Stempel

audatex AEF-nr. X04

* betreft akkoord voor de vastlegging van de schade op dit formulier