

AEF-nr.	Fabrikant	Model	Nederland BV				Eigenaar						
K10	Volvo	240 Sedan 09/75-12/93	audatex 13.06.86 © Copyright AUDATEX 1994				Kenteken	VOLVO					
Type		Code X	Uitvoeringsspecificatie Code X	Uitvoeringsspecificatie Code X	Uitvoeringsspecificatie Code X	Uitvoeringsspecificatie Code X	Tarieven						
STANDAARD INVOERGEDEGEVENS		▼ carburateur		OPTIONELE INVOERGEDEGEVENS		▼ velgen		Arbeidsstarief per AE		Spuittarief per AE		Excl. materiaal Incl. materiaal	
240 DL	K10 18	1986 ccm (2,0 Ltr) 60kW B20A ₂	N 1	schuifdak mech.	C 1	5 J x 14	S 1						
240 GL	K10 12	1986 ccm (2,0 Ltr) 66kW B19A ₂	N 2	zonnedak	V 6	5 1/2 J x 14	S 2						
240 GLE	K10 13	1986 ccm (2,0 Ltr) 74kW B200K ₂	T 6	▼		5 1/2 J x 14 lichtmetaal	S 3						
240 GLT	K10 14	2127 ccm (2,1 Ltr) 71kW B21A ₂	N 3	glas getint	F 4	6 J x 14 lichtmetaal	S 5						
240 Turbo	K10 15	2127 ccm (2,1 Ltr) 74kW B21A ₂	N 4	buitenspiegels mech. verst.	G 6	6 J x 15 lichtmetaal	S 4						
240 Diesel	K10 16	2316 ccm (2,3 Ltr) 85kW B230K ₂	T 1	buitenspiegels elektr. verst.	G 7								
240 DL Diesel	K10 19	2127 ccm (2,1 Ltr) 79kW B21A ₂	N 5	koplampreinigingsinstallatie		▼ banden							
242 L	K10 01	2316 ccm (2,3 Ltr) 81kW B230A ₂	N 6	ELEKTROLUX	I 6	165 R 14 .. T	R 1	Spuitmateriaal		51			
242 DL	K10 02	2316 ccm (2,3 Ltr) 82kW B23A ₂	N 7	koplampreinigingsinstallatie		175 R 14 .. T	R 2	Anti - roest		70 fl	Kleinmateriaal 27 fl		
244 L	K10 03	2316 ccm (2,3 Ltr) 83kW B230K ₂	O 7	BOSCH	I 5	185/70 R 14 .. T	R 3	behandeling		71 fl	** Aftrek 1 ^e schade 95 fl		
244 DL	K10 04			knipperlichten HELLA	K 1	185/70 R 14 .. H	R 4	Uitlijnen		74 fl	Begr. kosten rep. 90 fl		
244 DLI	K10 05	▼ inspuiting		knipperlichten CIBIE	K 2	195/60 R 15 .. H	R 5	Hulpstoffen		63 fl	Poetsen/reinigen 67 fl		
244 GL	K10 06	2316 ccm (2,3 Ltr) 83kW B230F ₂	N 8	▼									
244 GLI	K10 07	2316 ccm (2,3 Ltr) 85kW B230F ₂	O 9	voorspoiler	H 1								
244 GLE	K10 08	2127 ccm (2,1 Ltr) 90kW B21E ₂	N 9	achterspoiler	W 6								
244 GLT	K10 09	2316 ccm (2,3 Ltr) 96kW B23E ₂	O 1	sierstrepen	H 4								
244 Turbo	K10 10	2300 ccm (2,3 Ltr) 98kW B230 ₂	O 2	sierlijsten chroom	K 5								
244 GL D6	K10 11	2316 ccm (2,3 Ltr) 100kW B23E ₂	O 3	sierlijsten zwart	K 6								
		2315 ccm (2,3 Ltr) 103kW B23E ₂	O 4	▼									
		2127 ccm (2,1 Ltr) 114kW B21E ₂	O 5	centrale vergrendeling	G 1								
				ruitbediening v. elektr.	G 3								
				ruitbediening v./a. elektr.	G 5								
		▼ diesel		koplamphoogteregeling	I 7								
		2384 ccm (2,4 Ltr) 58kW D24 ₂	O 8	extra remlicht	W 8								
		2384 ccm (2,4 Ltr) 60kW D24 ₂	O 6	▼									
Uitvoeringsspecificatie Code X		▼ chasis-nr.		▼ wisselbak		▼		Bewerking		Benaming		▼AE % Bedrag	
v.a. ch.-nr. -L- 274965 (09/77)	D 1	4-versnellingen	P 1	bekleding stof	J 1	V	0731	Gloeilampen (VM)			fl		
v.a. ch.-nr. -M- 364650 (09/78)	D 2	4-versnellingen + Overdrive	P 2	bekleding velours	J 3	B	9950 ₃	Richtbankbedrag (HM)			fl		
v.a. ch.-nr. -A- 482505 (09/79)	D 3	5-versnellingen	P 3	bekleding leer	J 4	B	9952 ₃	Richtbank aanpassen + vtg. op en af					
v.a. ch.-nr. -B- 592110 (09/80)	D 4	automatisch	P 7	▼		B	0245 ₃	Richten voorzijde					
v.a. ch.-nr. -C- 686100 (09/81)	D 5			airconditioning	F 1	B	2695 ₃	Richten achterzijde					
v.a. ch.-nr. -D- 812610 (09/82)	D 6	▼ lak		inbouwvoorbereiding		B	1477 ₃	Richten zijkant L.					
v.a. ch.-nr. -E- 939340 (09/83)	D 7	2-K-acryl. (uni) rep.-lak	Y 2	airconditioning	F 3	B	1478 ₃	Richten zijkant R.					
v.a. ch.-nr. -F- 072450 (09/84)	D 8	2-lagen-metallic	Y 4	hoofdsteunen achter	L 1	B	0247 ₃	Dé-/montage t.b.v. spuitwerk					
v.a. ch.-nr. -G- 145710 (09/85)	D 9			airbag	T 5	B	9951	Dé-/montage delen LPG-installatie					
v.a. ch.-nr. -H- 215300 (09/86)	E 1	▼ spuitmethode		elektro-ventilator	U 9	V	9987	Koelvloeistof (VM)			fl		
v.a. ch.-nr. -J- 278400 (09/87)	E 2	spuiten deel in uitgeb. toestand	Y 8	stuurhuis CAM	U 1	V B	0734	Antenne (VM)			fl		
v.a. ch.-nr. -K- 334100 (09/88)	E 3	voersp. uitgeb. afsp. gemonteerd	Y 7	stuurhuis ZF	U 2	V B	2709	Trekhaak (VM)			fl		
v.a. ch.-nr. -L- 386700 (09/89)	E 4			stuurbevrachting	Q 1	*** Vrije deel							
v.a. ch.-nr. -M- 429800 (09/90)	E 5			remsysteem ATE	Q 8						fl		
v.a. ch.-nr. -N- 457500 (09/91)	E 6			antiblokkeersysteem	Q 7						fl		
v.a. ch.-nr. -P- 478400 (09/92)	E 7										fl		
Fantoom		Uitvoeringsspecificaties				Speciaal rapport							
Merk						Resultatenblad	1			R	Risico	fl	
						Controleblad	1	2			4 aant. - X - + aant. - X - zones = Totaal aant. - X -		
Model						Oude prijs	A			* Voor codes zie "Audatex-codekaart"			
						Prijdatum				** Alleen te gebruiken bij vervanging carrosserie			
Type						Tekst kort	1	Lang	2	*** Naar keuze invullen V,GV,B,H,GH,C,SV,SH,S of O 2) Motornummer			
						Geen spuitw.	L			Serie: 5	Wijzigingsdatum 15.07.94	(180594)	
										Volvo		240 Sedan	K10

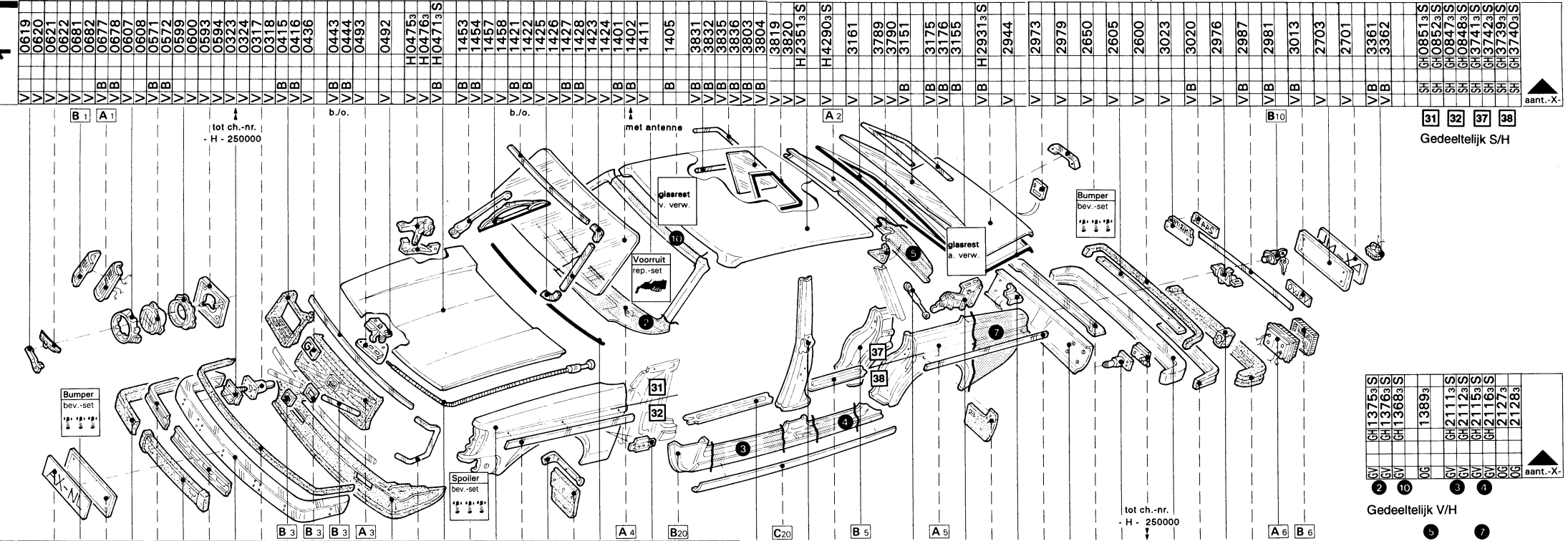

V	B	0256	V	B	0619
V	V	0350	V	V	0620
V	V	0258	V	V	0621
V	V	0311	V	V	0622
V	V	0312	V	V	0681
V	V	0343	V	V	0682
V	V	0344	V	V	0677
V	V	0310	V	V	0678
V	V	0345	V	V	0607
V	V	0281	V	V	0608
V	V	0300	V	V	0571
V	V	0431	V	V	0572
V	V	0434	V	V	0599
V	V	0423	V	V	0600
V	V	0424	V	V	0594
V	V	0410	V	V	0323
V	V	0391	V	V	0324
V	V	0421	V	V	0317
V	V	0422	V	V	0318
V	V	0500	V	V	0412
V	V	0403	V	V	0416
V	V	H07413	V	V	0436
V	V	H07423	V	V	0443
V	V	0775	V	V	0444
V	V	0776	V	V	0493
V	V	0895	V	V	0492
V	V	0896	V	V	H04753
V	V	0897	V	V	H04763
V	V	0898	V	V	H04713
V	V	0824	V	V	1453
V	V	H13613	V	V	1454
V	V	0815	V	V	1457
V	V	0816	V	V	1458
V	V	H21013	V	V	1421
V	V	H21023	V	V	1422
V	V	2191	V	V	1425
V	V	2192	V	V	1426
V	V	H21073	V	V	1427
V	V	H21083	V	V	1428
V	V	H22793	V	V	1423
V	V	H22803	V	V	1424
V	V	2197	V	V	1401
V	V	2198	V	V	1402
V	V	H34973	V	V	H23513
V	V	H34983	V	V	H42903
V	V	2997	V	V	3161
V	V	2998	V	V	3789
V	V	H34813	V	V	3790
V	V	H34823	V	V	3151
V	V	H30533	V	V	3175
V	V	H30543	V	V	3176
V	V	3683	V	V	3155
V	V	3684	V	V	3803
V	V	H27733	V	V	3804
V	V	H27743	V	V	3819
V	V	3613	V	V	3820
V	V	3614	V	V	H23513
V	V	H27113	V	V	H42903
V	V	2761	V	V	2944
V	V	2617	V	V	2973
V	V	2618	V	V	2979
V	V	2625	V	V	2650
V	V	2626	V	V	2605
V	V	2581	V	V	2600
V	V	2645	V	V	3023
V	V	2646	V	V	3020
V	V	2610	V	V	2976
V	V	2611	V	V	2987
V	V	2612	V	V	2981
V	V	3281	V	V	3013
V	V	3291	V	V	2703
V	V	3292	V	V	2701
V	V		V	V	3361
V	V		V	V	3362
V	V		V	V	GH08513
V	V		V	V	GH08523
V	V		V	V	GH08473
V	V		V	V	GH08483
V	V		V	V	GH08493
V	V		V	V	GH37413
V	V		V	V	GH37423
V	V		V	V	GH37393
V	V		V	V	GH37403
V	V		V	V	GH37403

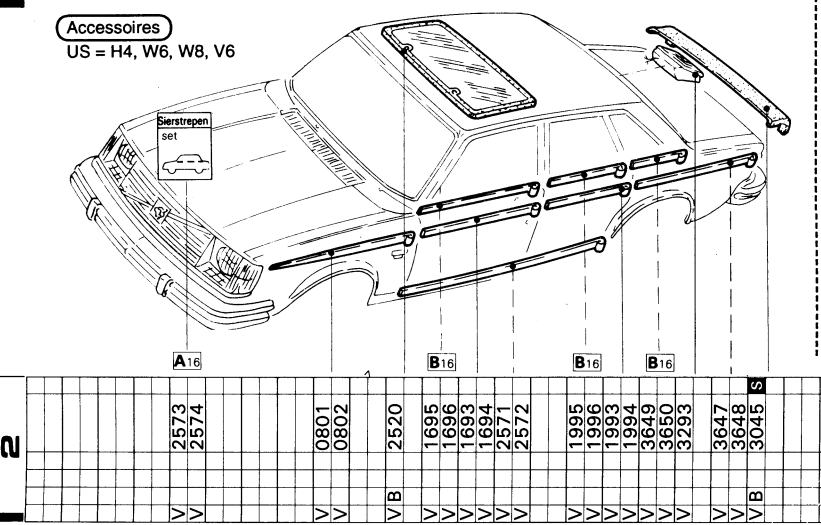

V	V	2573	V	V	0801
V	V	2574	V	V	0802
V	V		V	V	2520
V	V		V	V	1695
V	V		V	V	1696
V	V		V	V	1693
V	V		V	V	1694
V	V		V	V	3649
V	V		V	V	3650
V	V		V	V	3293
V	V		V	V	3647
V	V		V	V	3648
V	V		V	V	3045
V	V		V	V	1995
V	V		V	V	1996
V	V		V	V	1993
V	V		V	V	1994
V	V		V	V	3649
V	V		V	V	3650
V	V		V	V	3293
V	V		V	V	3647
V	V		V	V	3648
V	V		V	V	3045

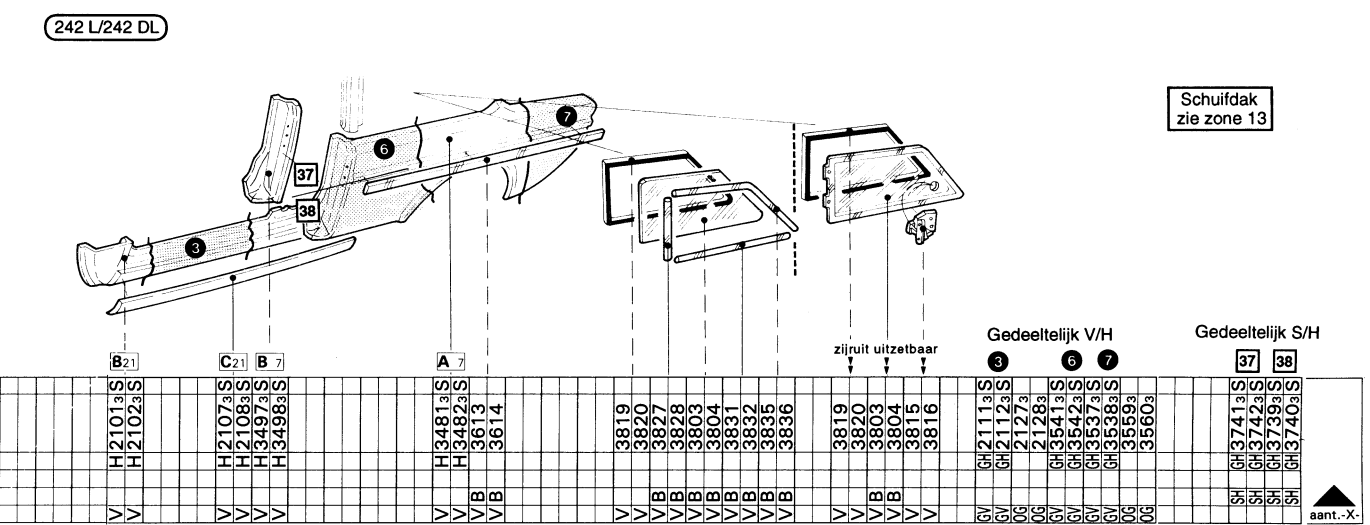

V	V	H21013	V	V	3819
V	V	H21023	V	V	3820
V	V	H21073	V	V	3827
V	V	H21083	V	V	3828
V	V	H34973	V	V	3803
V	V	H34983	V	V	3804
V	V		V	V	3831
V	V		V	V	3852
V	V		V	V	3835
V	V		V	V	3836
V	V		V	V	3819
V	V		V	V	3820
V	V		V	V	3803
V	V		V	V	3804
V	V		V	V	3815
V	V		V	V	3816
V	V		V	V	GH21113
V	V		V	V	GH21123
V	V		V	V	21273
V	V		V	V	21283
V	V		V	V	GH35413
V	V		V	V	GH35423
V	V		V	V	GH35373
V	V		V	V	GH35383
V	V		V	V	GH35393
V	V		V	V	GH35403
V	V		V	V	GH37413
V	V		V	V	GH37423
V	V		V	V	GH37393
V	V		V	V	GH37403
V	V		V	V	GH37403

10

VB	0481
V	4933
V	4934
V	4931
VB	4959
VB	4957
VB	4901
VB	4902
VB	4923
VB	4924
V	4991
V	4993
V	4982
VB	4927
VB	4979
VB	4980
VB	4903
VB	4904
VB	4971
VB	4972

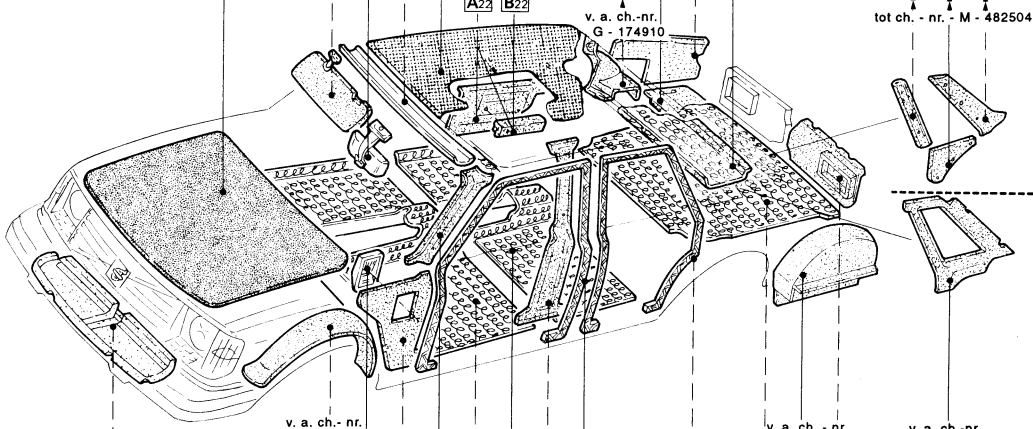

10

V	0980
VB	0843
VB	0844
V	4955
V	4956
VB	4939
VB	4940
VB	4941
VB	4942
VB	4875
VB	4876
VB	4947
VB	4948
V	1777
V	1778
V	2063
V	2064
VB	4978
V	4981
VB	4985
VB	4986
VB	4971
VB	4972

11

V	4419
V	4420
VB	4411
V	4447
V	4448
V	4428
V	4423
V	4424
V	4417
V	4418
VB	4411
V	4447
V	4412
V	4428
VB	H4331 S
V	4353
VB	4335
V	4349
V	4332
V	4345
V	4346
V	4355
V	4357
V	4352
V	4425
V	4426
V	4363
V	4364
V	4445
V	4446
V	4367
V	4356

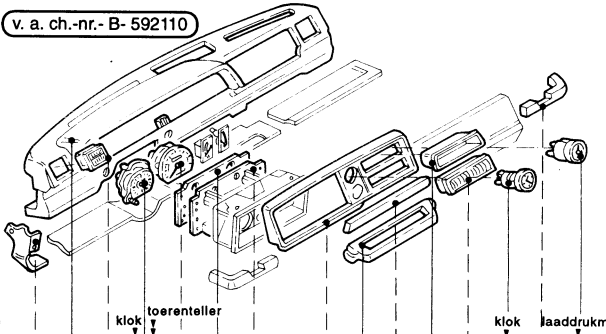
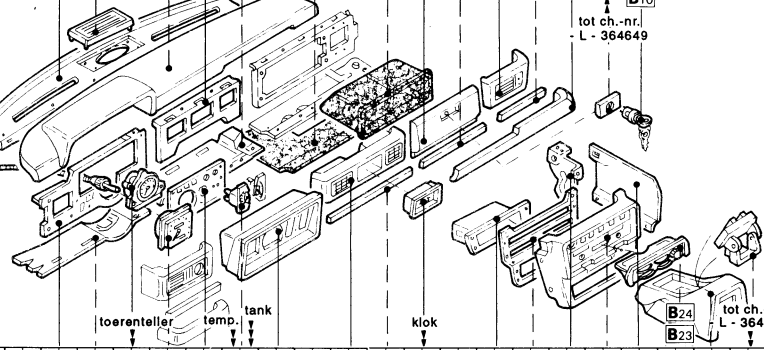
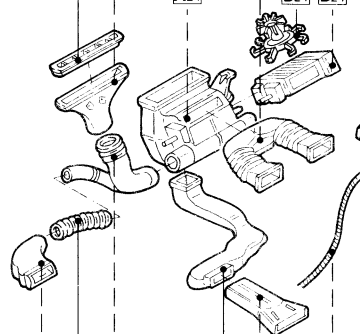
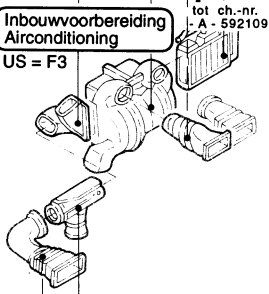

11

V	4439
V	4440
V	4449
V	4450
V	4419
V	4420
V	4437
V	4438
V	4435
V	4436
V	4376
V	4350
V	4351
V	4333
V	4334
V	4397
V	4375
V	4373
V	4384
V	4383
V	4371
V	4427
V	4362
V	4378
V	4365
V	4444
V	4393
V	4394
V	4443
V	4395
V	4396
V	4432
VB	4392
V	4653
V	4327
V	4328
VB	4335
V	4425
V	4426
V	4391
V	4397
V	4375
V	4373
V	4372
V	4343
V	4336
V	4362
V	4342
V	4427
V	4390
V	4363
V	4364
V	4389

Wisselbak
US = P1, P2, P3

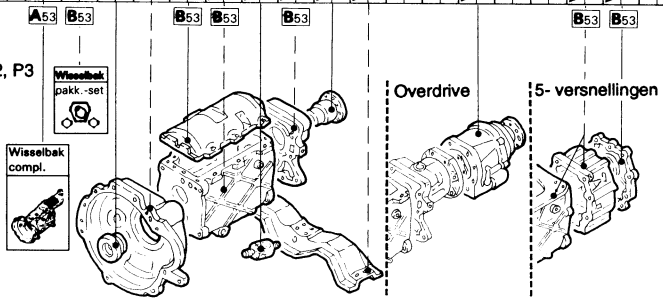

Autom.- bak
US = P7

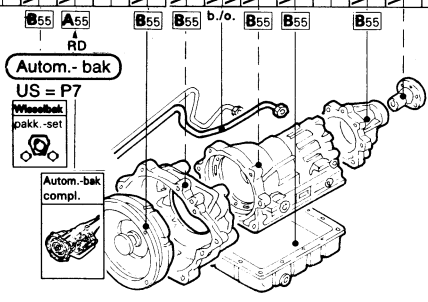

aant.-X

Elektro- ventilator
US = U9

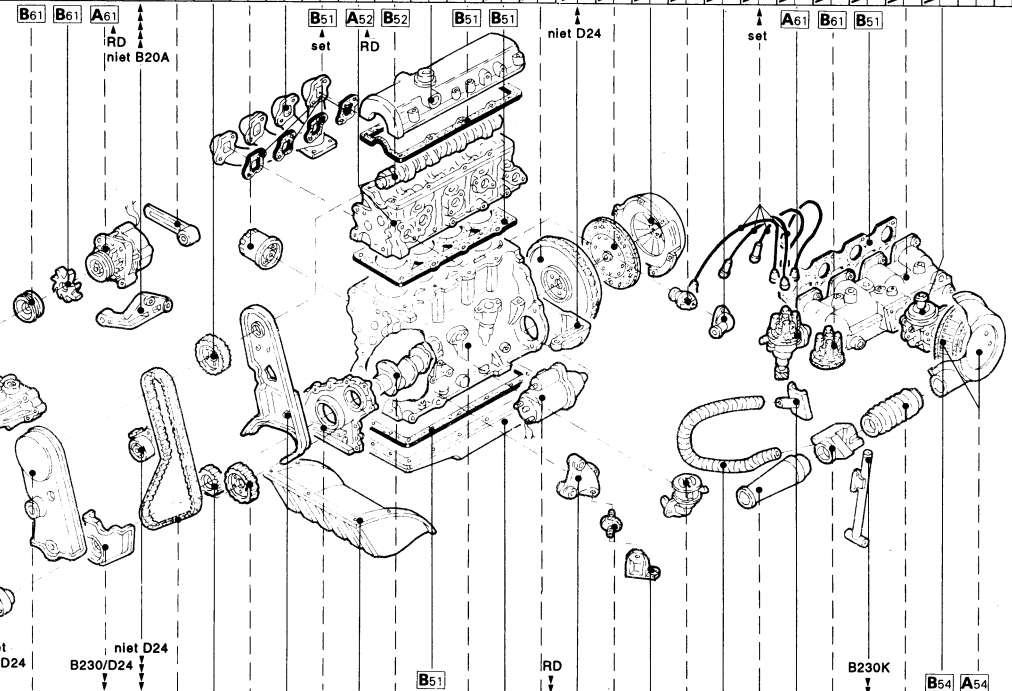
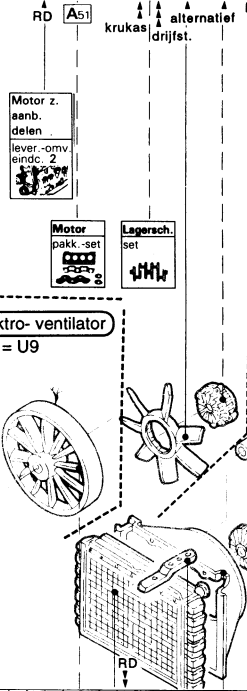

v. a. ch.-nr.-M- 364650

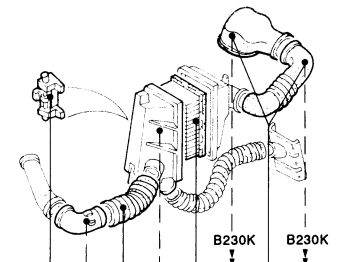

aant.-X

aant.-X

20

20

21

21

aant.-X

aant.-X

aant.-X

Stuurbekrachtiging
 US = Q1

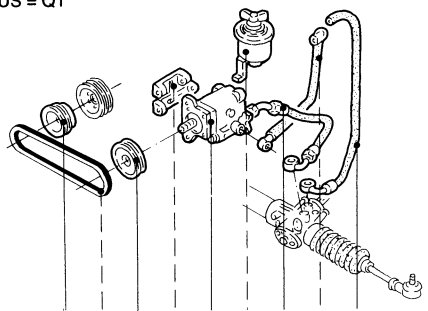

niet D24/
 B230/ B20A

B21 tot ch.-nr.- G - 174909
 B230 v. a. ch.-nr.- 072450

Airbag
 US = T5

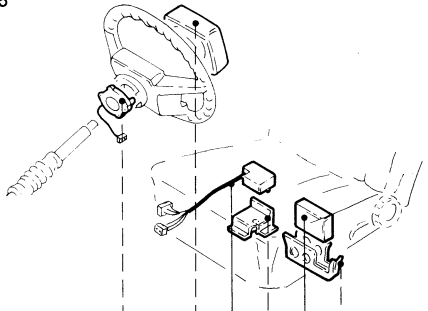

Antiblokkeersysteem
 US = Q7

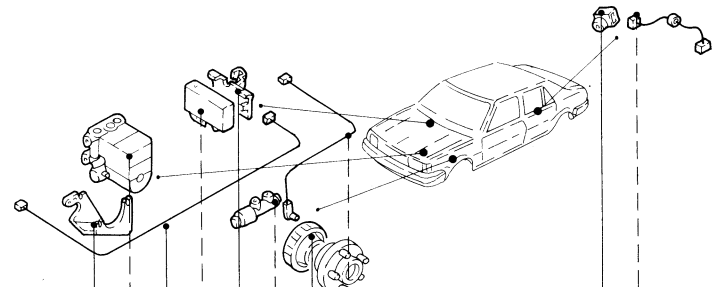

regelunit drukregelaar

7491
 7477
 7473
 7465
 C 7461
 7479
 7483
 7487
 7485

7444
 7411
 7440
 7435
 7443
 7437

7243
 C 7241
 9583
 7242
 7244
 7259
 7251
 7252
 7245
 7246

7253
 9586

aant.-X

