

FOX AIR SHOCK SET UP  
APPROXIMATE STARTING PRESSURES

FRONT SHOCK

REAR SHOCK

RIDER WEIGHT	PRESSURE
150	60
180	70
210	80
240	90

RIDER WEIGHT	PRESSURE
150	30
180	35
210	40
240	45

IF LIMITER STRAP TO LONG UNBOLT CROSS SHAFT AND TWIST ROPE TILL YOU GET THE DESIRED LENGTH OF 8 1/4". IF TO SHORT AFTER 3-4 RIDES PLEASE CONTACT YOUR DEALER FOR NEW ONE.

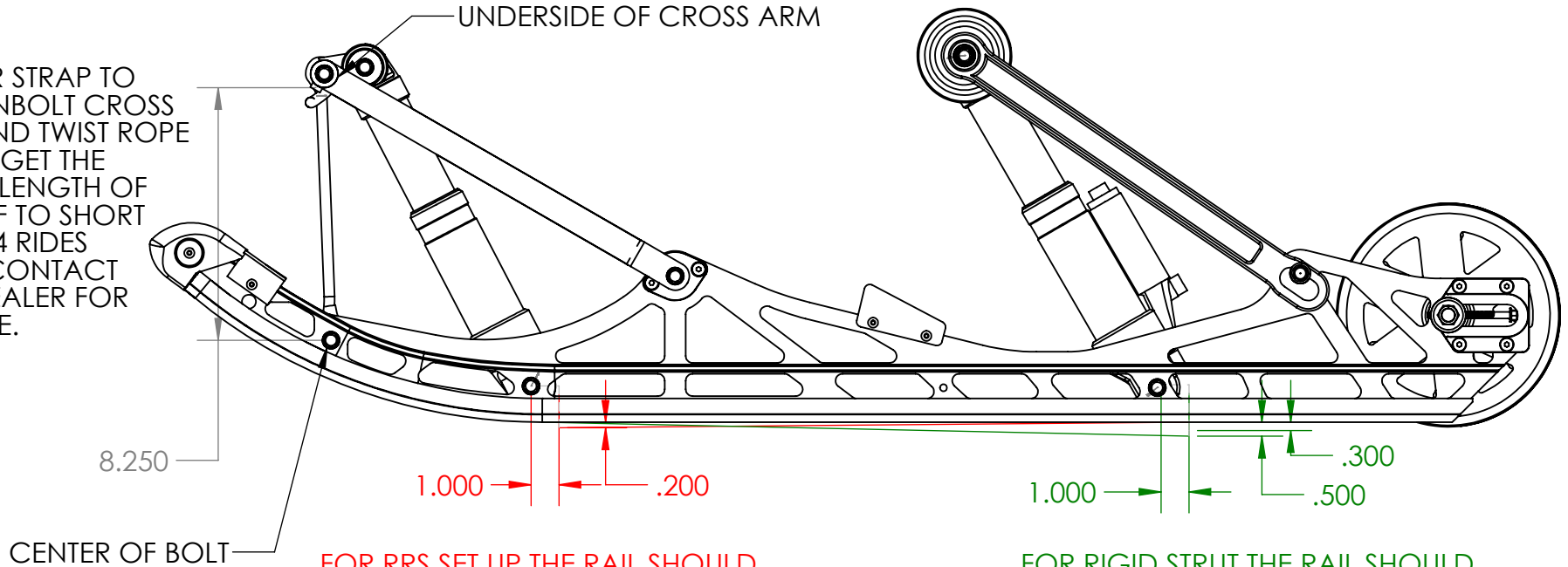

FOR RRS SET UP THE RAIL SHOULD BE .2" HIGH AT FRONT WHEN CALIPER ZERO'D AT REAR SHAFT AND MEASURED 1" BEHIND THE FRONT BOLT WITH BORE DEPTH END OF THE CALIPER. EACH REVOLUTION OF THE LOWER ROD END WILL CHANGE MEASUREMENT BY .050"

FOR RIGID STRUT THE RAIL SHOULD BE .3 TO .5" AT REAR WHEN CALIPER ZERO AT FRONT SHAFT AND MEASURED 1" BEHIND THE BOLT BORE DEPTH END OF THE CALIPER. TO ADJUST EACH 1 FULL REVOLUTION OF THE STRUT CHANGES MEASUREMENT BY .105"

TITLE:

YETI 2016 LIMITER STRAP LENGTH & STRUT SET UP

**Yeti SNOWMX**

A DIV. OF C3 POWERSPORTS 2014 LTD  
1 - 17 RENAULT CRESENT  
ST. ALBERT, ALBERTA. T8N 4B7  
PH 780 419-2040 www.c3powersports.com

MATERIAL	Material <not specified>		
		FINISH	
REV	DISCRPTION	DATE	DO NOT SCALE DRAWING

DRAWN BY:	
NAME	KEVIN FORSYTH
DATE	OCT 31-2016

SIZE	DWG. NO.	REV
<b>A</b>		
SCALE: 1:1	WEIGHT: 49.157	SHEET 1 OF 1