

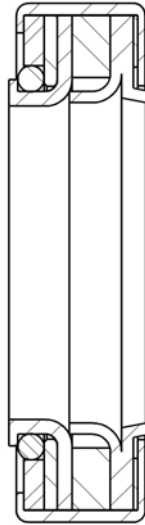

3511, 3517, 3522, 4511, 4517, 4522 TRIPLE LIP SEAL OWNERS MANUAL

(Use with Supplement Owner's Manual
G12-436 for GHB and BHB Pumps or
G12-209 for HB, SB, and BH pumps)



SAFETY INSTRUCTIONS

This is an industrial component. Only a qualified systems integrator should be allowed to design it into a system. The integrator must determine proper plumbing, mounting, driveline and guard components.

Improper installation or use could lead to a serious, even fatal, accident. The system integrator must communicate all safe operation procedures to the end user(s).

Before operation, fully understand and follow the instructions shown in this manual and any instructions communicated by the system integrator. No one should be allowed to operate or maintain this pump who has not been fully trained to work safely according to the configuration of the pump system and in accordance with all applicable government and industry regulations.

Roper Pump Company
P.O. Box 269
Commerce, GA 30529 USA

Telephone: (706) 335-5551
TeleFAX: (706) 335-5490
Email: sales@roperpumps.com
www.roperpumps.com

Installation Instructions for Triple Lip Seal

(STANDARD CONFIGURATION)

3511-4522

1. There are many different pump and seal arrangements. Depending on the arrangement, the installation of the triple lip seal could vary. If you do not know which pump or seal arrangement you have, collect nameplate data and refer to the Owners Manual for 3511-4522 (G12-209), to determine what you have. Consult a Roper distributor or Roper Pump Company if you have any questions.
2. When cleaning or lubricating, use only cleaning solutions and lubricants that are compatible with products being pumped and with sealing elastomers. **DO NOT** use petroleum base products with seals with EPR elastomers. Use a non-petroleum base lubricant with EPR elastomers.
3. It is very important the triple lip seal is not installed in such a way that it would have to slide over any retaining ring grooves. Use a small file or stone to break sharp edges of drive shaft keyway that will be under pump drive gear.
4. For “**BH**” pumps, the drive shaft should already be installed in pump. Lubricate drive end of drive shaft (32) and triple lip seal (10) with a light oil. Slide triple lip seal over shaft with two lips facing toward pump gears. Gently push seal past tapered area of shaft and down to front of seal chamber. Press triple lip seal into bore until back side is flush with face of seal chamber. Install packing washer (10B). Take care to use a tool that will not damage or distort seal casing. Install one packing washer (18). Secure seal retainer (9) in place. Refer to the Owners Manual for 3511-4522 (G12-209) for further pump disassembly or assembly instructions.
5. For “**BHB**”, “**GHB**”, “**GHBO**”, “**HB**” and “**SBFO**” pumps, prior to installing the drive shaft place the triple lip seal (10) with two lips facing toward seal chamber onto opening of seal chamber in backplate. Press triple lip seal into seal chamber until back side of seal is flush with face of seal chamber. Take care to use a tool that will not damage or distort seal casing. Install one packing washer (18). Secure seal retainer (9) in place. For “**HB**” and “**SBFO**” refer to the Owners Manual for 3511-4522 (G12-209) for further pump disassembly or assembly instructions. For “**BHB**”, “**GHB**”, and “**GHBO**” refer to the Owners Manual for 3511-4522 (G12-436) for further pump disassembly or assembly instructions.

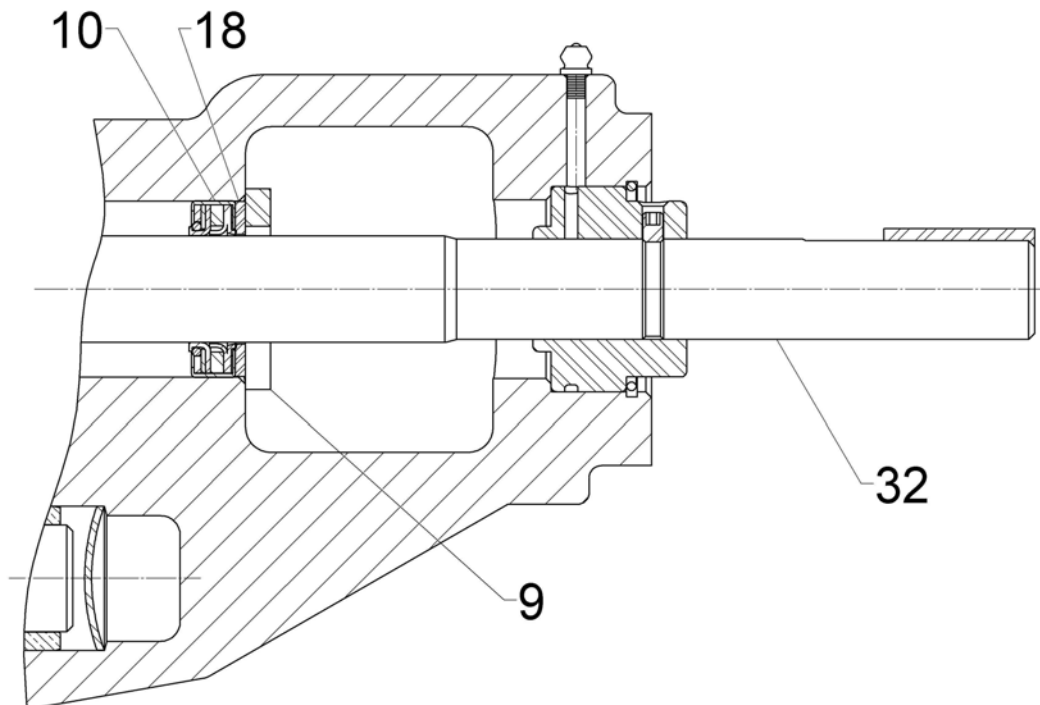

EXAMPLE OF STANDARD CONFIGURATION

Installation Instructions for Triple Lip Seal

(BARRIER FLUID OR FLUSH CONFIGURATION)

3511-4522

6. For “BH” pumps, the drive shaft should already be installed in pump. Lubricate drive end of drive shaft (32) and triple lip seal (10) with a light oil. Slide triple lip seal over shaft with two lips facing toward pump gears. Gently push seal past tapered area of shaft and down to front of seal chamber. Press triple lip seal into bore until seated in bottom of seal chamber. Take care to use a tool that will not damage or distort seal casing. Press lip seal (10A) into seal chamber bore. Install one packing washer (18). Secure seal retainer (9) in place. Refer to the Owners Manual for 3511-4522 (G12-209) for further pump disassembly or assembly instructions.
7. For “BHB”, “GHB”, “GHBO”, “HB” and “SBFO” pumps, prior to installing the drive shaft place the triple lip seal (10) with two lips facing toward seal chamber onto opening of seal chamber in backplate. Press triple lip seal into seal chamber until seated in bottom of seal chamber. Take care to use a tool that will not damage or distort seal casing. Press lip seal (10A) into seal chamber bore. Install one packing washer (18). Secure seal retainer (9) in place. For “HB” and “SBFO” refer to the Owners Manual for 3511-4522 (G12-209) for further pump disassembly or assembly instructions. For “BHB”, “GHB”, and “GHBO” refer to the Owners Manual for 3511-4522 (G12-436) for further pump disassembly or assembly instructions.

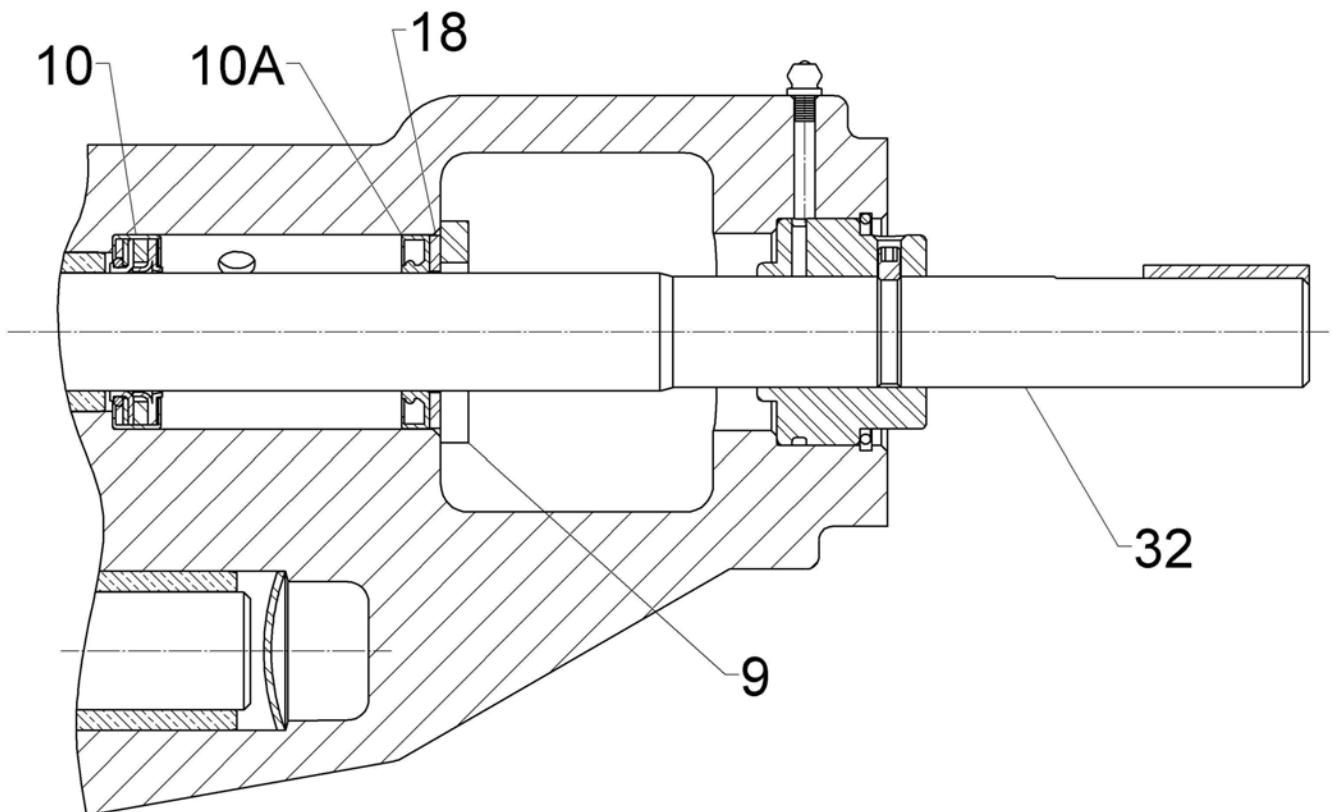

EXAMPLE OF BARRIER FLUID OR FLUSH CONFIGURATION