



Work Instruction: Install Front OX E-Locker

OX E-Locking Front Differential Kit (P/N-0502EUA00041N)

WORK INSTRUCTION OVERVIEW

⚠ WARNING

- DO NOT ATTEMPT THIS PROCEDURE IF YOU DO NOT HAVE PROPER TOOLS, TRAINING, AND FACILITIES.
- Never consider using a two-post lift that is not certified according to ANSI/ALI ALCTV-2011 or ANSI/UL 201. (autolift.org)
- Read and follow all instructions provided when installing this product. Failure to do so may result in placing occupants at risk of serious injury or death.
- To protect bystanders and the service technician(s), shut vehicle off, remove the Ignition Key and secure vehicle to prevent unintended movement.
- Never operate the vehicle in excess of manufacturer's specifications.

NOTICE the Initial Dealer Kit you received, contains (10) Hub Dust Caps (P/N-0641920) in the event one is damaged during removal.

TOOLS REQUIRED

<ul style="list-style-type: none"> ○ 10 mm Allen Wrench ○ 12 mm Socket ○ 14 mm Socket ○ 19 mm Socket ○ 21 mm Deep Well Socket ○ 50 mm Socket ○ Snap Ring Pliers ○ Brass Punch 	<ul style="list-style-type: none"> ○ Ball Peen Hammer ○ 18-1/2" Socket Extension ○ Protective Eye-wear ○ Pry Bars (Large) ○ Pry Bar (Thin) ○ Socket Wrench ○ Torque Wrench (Ft-Lbs) ○ Torque Wrench (Nm)
---	--

TORQUE SPECIFICATION





Tighten each fastener to the torque specification below:

- Front Spindle Nuts - 54 to 68 N•m (40 to 50 ft. lbs.)
- Front Brake Backing Plate Bolts - 34 to 47 N•m (25 to 35 ft. lbs.)
- Front Brake Caliper Mounting Bracket Bolts - 78 to 88 N•m (57 to 65 ft. lbs.)
- Front Differential Cover Bolts - 16 to 20 N•m (12 to 15 ft. lbs.)
- Front Differential Drain Plug - 27 to 40 N•m (20 to 30 ft. lbs.)
- Front Differential Filler Plug - 20 to 27 N•m (15 to 20 ft. lbs.)
- Front Differential Bearing Cap Bolts - 88 to 108 N•m (65 to 80 ft. lbs.)
- Ring Gear Bolts - Incrementally 40, 60, 80 then 90 N•m (30,

44, 59 then 66 ft. lbs.)

OX E-LOCKING FRONT DIFFERENTIAL KIT

Kit Number - 0502EUA00041N

Kit Component	Description	Qty
	ROXOR Locker Installation Kit Black RTV Sealer w/ Nozzle Gear Marking Compound Acid Brush Front Carrier Bearings Shim Pack Thread Locker	1
	OX Locker Electric Shift System Electric Actuator, Cable Mount Cylinder w/ Bracket Electrical Harness w/ Switch OX Locker Actuator Cable w/ Jam Nuts and Sleeve OX Locker Splash Shield Dielectric Grease Fastener Kit	1
	OX Locker Front Differential Cover w/ Shift Fork	1
	OX Locker Front Differential	1

REMOVAL PROCEDURE

Remove Front Axle Carrier

1. Position the vehicle on a hoist and raise to a comfortable work height. Refer to Operator's Guide for proper lifting locations.





Work Instruction: Install Front OX E-Locker

OX E-Locking Front Differential Kit (P/N-0502EUA00041N)

2. Remove the front differential drain plug with a 10 mm Allen wrench and allow the fluid to drain.



3. Remove front wheel and tire with a 21 mm socket.



4. Remove (1) hub dust cap using two pry bars, then remove (1) outer axle shaft snap ring using snap ring pliers.

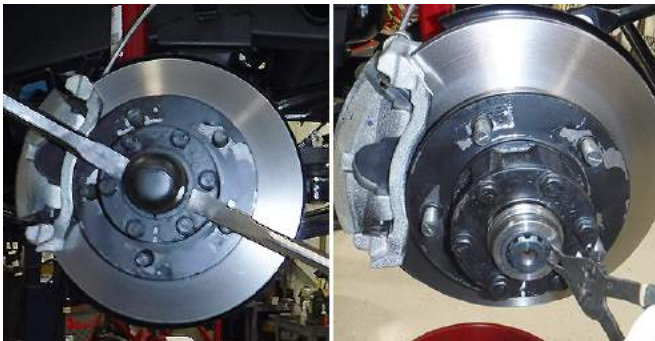

5. Remove (6) 14 mm axle drive flange bolts and remove flange.



6. Flatten all outer spindle nut, toothed lock washer tabs.



7. Remove (1) outer spindle nut, (1) toothed lock washer and (1) inner spindle nut with a 50 mm socket.



8. Remove the master tie rod assembly cotter pin and castle nut with a 19 mm socket. Separate and secure it forward out of the way of the differential cover.



9. Remove (2) brake caliper mounting bracket bolts using a 19 mm socket and hang out of the way.





Work Instruction: Install Front OX E-Locker

OX E-Locking Front Differential Kit (P/N-0502EUA00041N)

10. Use caution when removing front wheel hub, brake rotor and bearings. Be sure to keep all parts in their original location and orientation.



11. Remove (6) 14 mm brake backing plate bolts.



12. Remove wheel bearing spindle.



13. Pull front axle shaft assembly out until you feel it disengage the differential.

Then repeat all previous steps on opposite side, before going to the next step in this procedure.



14. Remove (10) 12 mm differential cover bolts.



15. Mark differential bearing caps so they can be reinstalled in their original orientation, then remove (4) bearing cap bolts with a 19 mm socket.



16. Rotate the differential into a position to pry on the casting. Then pry the differential from the axle assembly.





Work Instruction: Install Front OX E-Locker

OX E-Locking Front Differential Kit (P/N-0502EUA00041N)

17. Clean the axle and cover sealing surfaces.

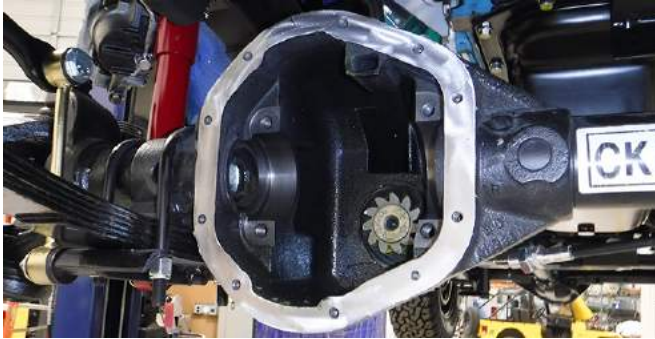

4. Measure the difference between the overall height of the new Front Axle Carrier and original. Identify and record the difference between the two heights.



BENCH PROCEDURE

Measure, Record and Build Up new Front Axle Carrier

1. Using a granite table and height gauge, set-up the new Carrier to dimensionally match the original carrier. The two critical dimensions are the Ring Gear Flange height and the overall Carrier height.



5. Add or subtract shims to the Passengers side of the carrier until the two heights are identical.



2. Measure the difference between the new and original Ring Gear Flange height. Identify and record the difference between the two heights.



6. Clean and apply a few drops of the supplied Loctite 263 to the end of each Ring Gear Bolt.



3. Add or subtract shims to the Driver's side of the carrier until the two heights are identical.



7. Install the Ring Gear to the new Front Axle Carrier. Torque bolts incrementally, in a criss-cross pattern, gradually increasing torque until the specifications are met.

CAUTION The Ring Gear bolts are hardened and left hand thread. Failure to install them properly may result in part damage.





Work Instruction: Install Front OX E-Locker

OX E-Locking Front Differential Kit (P/N-0502EUA00041N)

INSTALLATION PROCEDURE

Re-install Front Axle Carrier

1. Install Carrier into the Front Axle Housing. Then install both Differential Carrier Bearing Caps in original location and torque to specifications.



2. Check to ensure that backlash is between .005" - .010" (.13 mm - .25 mm)

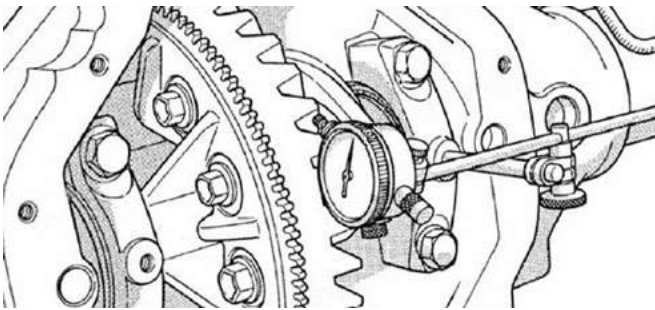

3. Use gear marking compound to check for proper gear mesh.



4. Push axles in until they engage the differential.



5. Test fit the OX locker front cover making sure the shift fork properly engages the lock ring.



6. Apply a generous bead of the supplied RTV sealer to axle housing.





Work Instruction: Install Front OX E-Locker

OX E-Locking Front Differential Kit (P/N-0502EUA00041N)

7. Install the OX Locker Actuator Cable (short barrel end) and torque to specifications. The core cable (1/4-28 thread) does not thread into the Cover Piston and Shift Fork.



8. Install (10) 12 mm differential cover bolts and torque to specifications.



9. Install wheel bearing spindle, then install (6) 14 mm backing plate bolts and torque to specifications.



10. Install hub and rotor assembly, then install (1) inner spindle nut, (1) toothed lock washer and (1) outer spindle nut and torque to specifications. Bend at least one tab on the toothed lock washer.



11. Install brake caliper mounting bracket bolts using a 19 mm socket and torque to specifications.



12. Slide the axle forward slightly and install the snap ring.





Work Instruction: Install Front OX E-Locker

OX E-Locking Front Differential Kit (P/N-0502EUA00041N)

13. Install master tie rod assembly, install castle nut and torque to specifications, then install cotter pin and fold one end over nut.



14. Install front wheel and tire and torque to specifications.



15. Install and torque Front Differential Drain Plug to specifications.



INSTALL ACTUATOR PROCEDURE

1. Separate the cable mount cylinder and bracket from the electric actuator by removing (2) fasteners.

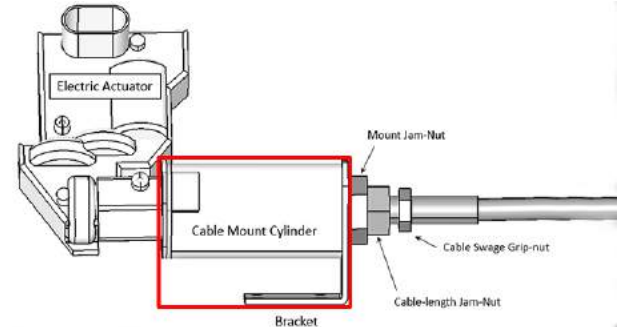

2. Mount the cable mount cylinder and bracket to (1) radiator support to body frame bolt.

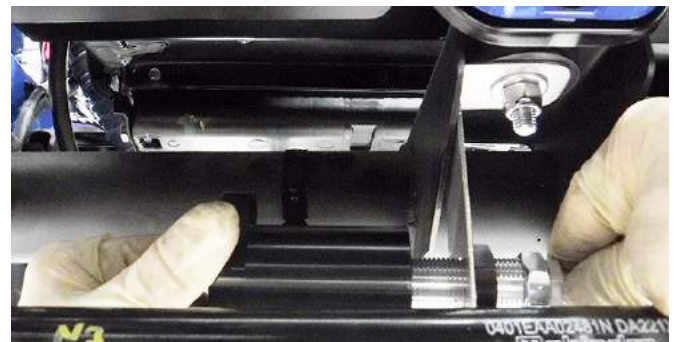

3. Apply none drying lubricant to the OX locker actuator cable (long barrel end), install the threaded sleeve and tighten cable length jam nut.





Work Instruction: Install Front OX E-Locker

OX E-Locking Front Differential Kit (P/N-0502EUA00041N)

4. Adjust the static OX locker cable length between 1/16 - 1/8" past the cable mount cylinder edge as shown. Then snug the mount jam nut and cable length jam nut.

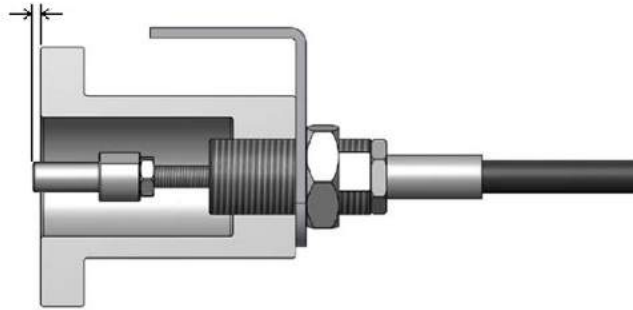

5. Reinstall the electric actuator to cable mount cylinder using the (2) fasteners removed earlier and hand tighten.



6. Connect supplied wire harness to actuator. Then connect panel clip to lower radiator support, route the harness along the right side of radiator and down the right fender rail under wire loom retainers.



7. Remove one of the bulkhead grommets and install a slit/ hole to route wire harness thru.



8. Connect harness ground to ground stub near battery. Then remove the inline fuse and route OX Locker harness thru bulkhead.



9. Remove the Deutsch connector from the Ignition Switch and install the red power wire into the position shown.

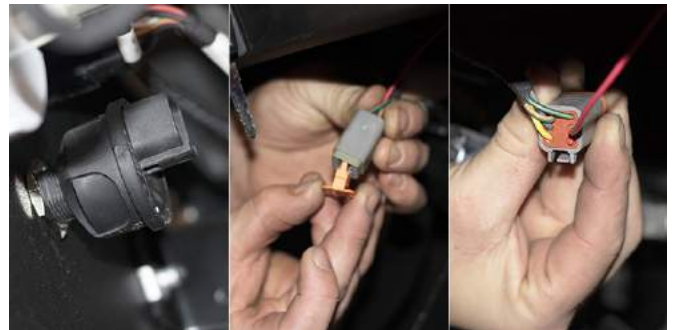



Work Instruction: Install Front OX E-Locker

OX E-Locking Front Differential Kit (P/N-0502EUA00041N)

10. Reconnect the Deutsch connector to the Ignition Switch, remove one of the switch plates from the dash and then route the rest of the OX Locker Harness thru the opening.



11. Reinstall the inline fuse. Connect the OX Locker Switch to the harness following the color scheme listed on the switch, then install switch to dash panel. Power on the Ignition Key and verify the Electric Actuator is working. The switch will light up when the OX Locker is engaged. If



12. Verify that the system is engaging and disengaging the Front Axles properly. Add fluid to the Front Differential and secure the OX Locker Cable and Harness before giving your ROXOR a trial test. Refer to Operator's Guide for Differential Fluid specifications and quantity.

