



**DIVISION: 07 00 00—THERMAL AND MOISTURE PROTECTION**

**Section: 07 21 00—Thermal Insulation**

**REPORT HOLDER:**

**RMAX®, A BUSINESS UNIT OF SIKA CORPORATION**

**EVALUATION SUBJECT:**

**RMAX® THERMASHEATH® TSX-8500, TSX 8510, ECOMAXci FR and ECOMAXci FR WHITE INSULATION BOARDS**

**1.0 EVALUATION SCOPE**

**Compliance with the following codes:**

- 2018, 2015, 2012 and 2009 *International Building Code®* (IBC)
- 2018, 2015, 2012 and 2009 *International Residential Code®* (IRC)
- 2018, 2015, 2012 and 2009 *International Energy Conservation Code®* (IECC)

**Properties evaluated:**

- Physical properties
- Surface-burning characteristics
- Thermal resistance
- Attic and crawl space installation
- Water vapor transmission
- Exterior walls in Types I through IV construction

**2.0 USES**

**2.1 Thermasheath®:**

Rmax® Thermasheath® insulation boards are used as nonstructural, thermal insulating materials in Types I, II, III, IV and V construction (IBC) and dwellings under the IRC.

Thermasheath® insulation boards, when covered by an approved thermal barrier, may be used within or on interior walls, roof assemblies, floor assemblies, ceiling assemblies and wall cavities in any construction type. The insulation boards can be used at the perimeter or under flat concrete slab on grade construction, or on the exterior or interior of basement foundation walls in any construction type. They also can be used on the outside faces of exterior walls of Type V-B (IBC) construction or dwellings under the IRC.

Thermasheath® insulation boards may be used in attics and crawl spaces without a thermal barrier or an ignition barrier required by the code, when installed in accordance with Section 4.2.1.

**2.2 TSX-8500, TSX-8510, ECOMAXci FR and ECOMAXci FR White:**

Rmax® TSX-8500, TSX-8510, ECOMAXci FR and ECOMAXci FR White insulation boards are used as nonstructural, thermal insulating materials in Types I, II, III, IV and V construction (IBC) and dwellings under the IRC.

The insulation boards may be used without a thermal barrier within or on interior walls, the inside face of exterior walls, roof assemblies, floor assemblies, ceiling assemblies and wall cavities in any construction type. The insulation boards may also be used at the perimeter or under flat concrete slab on grade construction and on the exterior or interior of basement foundation walls in any construction type. They also may be used on the outside faces of exterior walls of any type construction or dwellings under the IRC. When used in exterior walls in Types I, II, III and IV construction, construction must be in accordance with Section 4.4.

TSX-8500, TSX-8510, ECOMAXci FR and ECOMAXci FR White insulation boards may be used in attics and crawl spaces without a thermal barrier or an ignition barrier required by the code, when installed in accordance with Section 4.3.2.

**3.0 DESCRIPTION**

**3.1 Materials:**

**3.1.1 General:** Rmax® insulation boards are nonstructural, closed-cell, rigid polyisocyanurate, foam plastic insulation boards that are faced on both sides. The foam plastic core has a nominal density of 2 pcf (32 kg/m³). The boards are available in various lengths and widths.

**3.1.2 Thermasheath®:** Thermasheath® insulation boards consist of a polyisocyanurate foam core described in Section 3.1.1, faced on both sides with aluminum foil bonded to kraft paper. The boards have square edges and are available in thicknesses of 1/2 inch to 4 1/2 inches (12.7 mm to 114 mm). Thermasheath® insulation boards are Type I, Class 1, materials in accordance with ASTM C1289.

**3.1.3 TSX-8500:** TSX-8500 insulation boards consist of the polyisocyanurate foam core described in Section 3.1.1, with a silver facer consisting of aluminum-foil bonded to glass-fiber mat on one side. The other side is faced with either aluminum-foil bonded to glass-fiber mat or a sheet consisting of aluminum foil bonded to kraft paper. The

boards have square edges and are available in thicknesses of 1/2-inch to 4 1/2 inches (12.7 mm to 114 mm). TSX-8500 insulation boards are Type I, Class 1, materials in accordance with ASTM C1289.

**3.1.4 TSX-8510:** TSX-8510 is the same as TSX-8500 except that the silver facer is replaced with a white facer made of the same material.

**3.1.5 ECOMAXci FR:** ECOMAXci FR insulation boards consist of the polyisocyanurate foam core described in Section 3.1.1, with a silver facer consisting of aluminum-foil bonded to glass-fiber mat on both sides. The boards have square edges and are available in thicknesses of 1/2-inch to 4 1/2 inches (12.7 mm to 114 mm). ECOMAXci FR insulation boards are Type I, Class 1, materials in accordance with ASTM C1289.

**3.1.6 ECOMAXci FR White:** ECOMAXci FR White is the same as ECOMAXci FR except that the silver facer is replaced with a white facer made of the same material.

### 3.2 Surface-burning characteristics:

The Thermasheath® insulation boards have a flame-spread index of 25 or less and a smoke-developed index of 450 or less at a maximum thickness of 4 1/2 inches (114 mm), when tested in accordance with ASTM E84.

The TSX-8500, TSX-8510, ECOMAXci FR and ECOMAXci FR White insulation boards have a flame-spread index of 25 or less and a smoke-developed index of 450 or less at a maximum thickness of 4 1/2 inches (114 mm), when tested in accordance with ASTM E84.

### 3.3 Thermal Resistance:

The insulation boards have thermal resistances, *R*-values, at a mean temperature of 75°F (24°C), as shown in Table 1.

### 3.4 Vapor Permeability:

At a minimum thickness of 1/2 inch (12.7 mm), the insulation boards have vapor permeance of less than 0.1 perm [5.7x10<sup>12</sup> kg/(Pa-s-m<sup>2</sup>)] when tested in accordance with ASTM E96 (desiccant method) (Procedure A), and qualify as a Class I vapor retarder.

## 4.0 INSTALLATION

### 4.1 General:

The insulation boards must be installed in accordance with the Rmax® published installation instructions, the applicable code and this report. The manufacturer's published installation instructions must be available on the jobsite at all times during installation.

The insulating boards may be installed on any or all surfaces up to a thickness of 12 inches (305 mm) based on room corner fire testing in accordance with UL 1715 (NFPA 286), when covered with a minimum 1/2-inch-thick (12.7 mm) gypsum board complying with the applicable code. Exceptions to the requirement of a thermal or ignition barrier covering are detailed in Section 4.2.1 for Thermasheath or Sections 4.3.1 and 4.3.2 for TSX-8500, TSX-8510, ECOMAXci FR and ECOMAXci FR White. The insulation boards may be installed in either single or multiple layers up to the maximum thickness. When installed against wood or steel framing, the fasteners must be of sufficient length to penetrate into wood framing a minimum of 3/4 inch (19 mm) or through the steel framing a minimum <sup>29</sup>/<sub>64</sub> inch (11.4 mm).

For cementitious exterior wall coating applications, fasteners for insulations boards thicker than 1 1/2 inches (38 mm) must take into account for lateral resistance to provide support for the exterior wall coatings. Exterior wall assemblies, exterior finishes or wall covering assemblies must be structurally adequate to resist transverse loads. All

walls must be braced in accordance with 2018 and 2015 IBC Sections 2308.6.1 (2012 and 2009 IBC Sections 2308.9.3 and 2308.12.4) or 2018, 2015 and 2012 IRC Section R602.10.2 [2009 IRC R602.10.1], as applicable.

### 4.2 Thermasheath®—Installation without a Prescriptive Ignition Barrier:

**4.2.1 Attics and Crawl Spaces:** Thermasheath® insulation boards, at a maximum thickness of 1 inch (25.4 mm), may be used on walls of attics or crawl spaces with no covering applied to the attic or crawl space side of the foam plastic when installation is in accordance with all of the following conditions:

- Entry to attic or crawl space is only to service utilities, and no storage is permitted.
- There are no interconnecting attic or crawl space areas.
- Air in the attic or crawl space is not circulated to other parts of the building.
- Attic ventilation is provided when required by 2018 IBC Section 1202.3 (2015 IBC Section 1203.2) or IRC Section R806, as applicable, except unvented attics are permitted under the conditions prescribed in 2018, 2015 and 2012 IRC Section R806.5 (2009 IRC Section R806.4).
- Under-floor (crawl space) ventilation is provided when required by 2018 IBC Section 1202.4 [2015 IBC Section 1203.4 (2012 and 2009 IBC Section 1203.3)] or IRC Section R408.1, as applicable.
- Combustion air is provided in accordance with *International Mechanical Code*® (IMC) Section 701.

### 4.3 TSX-8500, TSX-8510, ECOMAXci FR and ECOMAXci FR White:

**4.3.1 Installation without a Prescriptive Thermal Barrier:** TSX-8500, TSX-8510, ECOMAXci FR and ECOMAXci FR White insulation boards may be installed without an approved thermal barrier when the boards are installed on walls only or ceilings only based on room corner fire testing in accordance with UL 1715 (NFPA 286). Without a thermal barrier, the insulation boards may be installed up to a maximum thickness of 4 1/2 inches (114 mm) on walls only or 12 inches (305 mm) on ceilings only. Insulation boards may be installed in either single or multiple layers up to the maximum thickness.

### 4.3.2 Installation without a Prescriptive Ignition Barrier - Attics and Crawl Spaces:

TSX-8500, TSX-8510, ECOMAXci FR and ECOMAXci FR White insulation boards at a maximum thickness of 12 inches (305 mm) on ceilings only or 4 1/2 inches (114 mm) on walls only with no covering applied to the attic or crawl space side of the foam plastic when installation is in accordance with all of the following conditions:

- Attic ventilation is provided when required by 2018 IBC Section 1202.3 (2015 IBC Section 1203.2) or IRC Section R806, as applicable except unvented attics are permitted under the conditions prescribed in 2018, 2015 and 2012 IRC Section R806.5 (2009 IRC Section R806.4).
- Under-floor (crawl space) ventilation is provided when required by 2018 IBC Section 1202.4 [2015 IBC Section 1203.4 (2012 and 2009 IBC Section 1203.3)] or IRC Section R408.1, as applicable.
- Combustion air is provided in accordance with IMC Section 701.

**4.4 Exterior Walls in Types I, II, III, and IV Construction:**

When TSX-8500, TSX-8510, ECOMAXci FR and ECOMAXci FR White are used on exterior walls of Type I, II, III and IV construction, the assembly must comply with 2015 and 2012 IBC Sections 1403.5 and 2603.5 (2009 IBC Section 2603.5) and this section, and the insulation boards must be installed at a maximum thickness of 3 inches (76 mm). The potential heat of the TSX-8500, TSX-8510, ECOMAXci FR and ECOMAXci FR White insulation board is 1847 BTU/ft<sup>2</sup> (21 MJ/m<sup>2</sup>) per inch of thickness when tested in accordance with NFPA 259. Wall assemblies complying with this section are described in Table 2.

**5.0 CONDITIONS OF USE**

The Rmax<sup>®</sup> foam plastic insulation boards described in this report comply with, or are suitable alternatives to what is specified in, those codes listed in Section 1.0 of this report, subject to the following conditions:

- 5.1 Installation must comply with this report and the manufacturer’s published instructions. In the event of a conflict between this report and the manufacturer’s published installation instructions, this report governs.
- 5.2 The insulation boards must be covered with an approved exterior wall covering, including a water-resistant barrier complying with the IBC Section 1404.2 or IRC Section R703.2, as applicable.
- 5.3 The wall covering placed over the foam plastic boards must be structurally adequate to resist transverse loads. All walls must be braced in accordance with 2015 IBC Section 2308.6.1 (2012, 2009 IBC Sections 2308.9.3 and 2308.12.4) or IRC Section R602.10, as applicable.
- 5.4 The insulation boards must not be used as a nailing base for exterior siding materials. All nailing must be into the wall framing as required by the siding manufacturer’s instructions or the applicable code.
- 5.5 Except as described in Sections 4.2.1, 4.3.1 and 4.3.2 the insulation boards must be separated from the interior of the building by an approved thermal barrier of ½-inch-thick (12.7 mm) gypsum board or equivalent thermal barrier complying with, and installed in accordance with, IBC Section 2603.4 or IRC Section R316.4, as applicable.
- 5.6 Use of the insulation board in areas where the probability of termite infestation is “very heavy” must be in accordance with 2018 and 2015 IBC Section 2603.8

[2012 IBC Section 2603.9 (2009 IBC Section 2603.8)] and 2018, 2015, 2012 and 2009 IRC Section R318.4, as applicable.

- 5.7 Jobsite certification and labeling of the insulation must comply with 2018 and 2015 IRC Section N1101.10 [2012 IRC Section N1101.12 (2009 IRC Section N1101.4)] or 2018, 2015 and 2012 IECC Section C303.1 or R303.1.1 and R401.3 (2009 IECC Section 303.1), as applicable.
- 5.8 The insulation boards are produced by Rmax<sup>®</sup> in Dallas, Texas; Fernley, Nevada and Greer, South Carolina, under a quality-control program with inspections by ICC ES.

**6.0 EVIDENCE SUBMITTED**

- 6.1 Data in accordance with the ICC-ES Acceptance Criteria for Foam Plastic Insulation (AC12), dated June 2015 (editorially revised October 2017), including testing in accordance with Appendix B.
- 6.2 Reports of room corner tests in accordance with UL 1715 and NFPA 286.
- 6.3 Report of potential heat test in accordance with NFPA 259.
- 6.4 Reports of fire propagation characteristics testing in accordance with NFPA 285.

**7.0 IDENTIFICATION**

- 7.1 The boards are packaged in bundles that bear a label including the name and address of RMAX, the date of manufacture, the ASTM C1289 type, the surface burning characteristics and the evaluation report number (ESR-1864).
- 7.2 The report holder’s contact information is the following:

**RMAX<sup>®</sup>, A BUSINESS UNIT OF SIKA CORPORATION**  
**13524 WELCH ROAD**  
**DALLAS, TEXAS 75244-5291**  
**(972) 387-4500**  
[www.rmax.com](http://www.rmax.com)

**TABLE 1—THERMAL RESISTANCE (R-VALUES) FOR THERMASHEATH<sup>®</sup>, TSX-8500, TSX-8510, ECOMAXci FR and ECOMAXci FR White**

<b>THICKNESS (inches)</b>	<b>R-VALUE [(°F · ft.<sup>2</sup> · hr.)/Btu] AT 75°F MEAN TEMPERATURE</b>
1	6.0
4.5	32
12	84

For SI: 1 inch = 25.4 mm, 1°F·ft<sup>2</sup>·hr/Btu = 0.176 m<sup>2</sup>·K/W, 1°F = 1.8°C+32.

TABLE 2—NFPA 285 COMPLYING EXTERIOR WALL ASSEMBLIES

WALL COMPONENT	MATERIALS
<b>Base Wall System</b> Select option 1, 2 or 3	1. Concrete wall 2. Concrete masonry wall 3. 1 layer – 5/8"-thick Type X gypsum wallboard on interior, installed over steel studs: minimum 3 5/8" depth, minimum 20 gauge at a maximum of 24" o.c. with lateral bracing every 4' vertically
<b>Floorline Firestopping</b>	4 lb./cu ft. mineral wool in each stud cavity at each floorline – attached with Z-clips.
<b>Cavity Insulation</b> Select option 1, 2 or 3	1. None 2. Any noncombustible insulation per ASTM E136 3. Any Fiberglass batt insulation (faced or unfaced)
<b>Exterior Sheathing</b> Select option 1 or 2	1. None 2. Minimum 1/2"-thick exterior gypsum board sheathing complying with ASTM C1396.
<sup>2</sup> <b>Water-Resistive Barrier Applied to Exterior Sheathing</b> Select option 1 or 2	1. None 2. Any water-resistive barrier that has been tested in accordance with NFPA 285.
<b>Exterior Insulation</b>	Rmax <sup>®</sup> TSX-8500, TSX-8510, ECOMAXci FR and ECOMAXci FR White Rigid Insulation – 3" max. total thickness (single or multiple layers)
<b>Exterior Veneer</b> Select option 1, 2, 3, 4, 5 or 6	1. Brick – Nominal 4" clay brick or veneer with maximum 2" air gap behind the brick. Brick ties/anchors 24" o.c. (max) 2. Stucco – Minimum 3/4"-thick exterior cement plaster and lath with an optional secondary water-resistive barrier between the exterior insulation and the lath. The secondary WRB shall not be full-coverage asphalt or butyl-based self-adhered membranes. 3. Limestone – Minimum 2"-thick. Any standard installation technique can be used. 4. Natural Stone – Minimum 2"-thick. Any standard installation technique can be used. 5. Terracotta cladding <sup>1</sup> – Minimum 1 1/4"-thick. Any standard installation technique can be used. 6. Mitsubishi Plastic Composites America, Inc., Alpolic <sup>®</sup> /fr wall panels (see ICC-ES <a href="#">ESR-2653</a> ) or Alcoa Architectural Products, Reynobond <sup>®</sup> FR Metal Composite Material (MCM) 6-mm panels (see ICC-ES <a href="#">ESR-3435</a> ) where there is no exterior insulation in the cavity behind the panels.

For **SI**: 1 inch = 25.4 mm

<sup>1</sup>Fasteners used for securing the terracotta must penetrate through the foam plastic into wood or steel framing and the system must be designed to handle cladding load and wind load per applicable code.

<sup>2</sup>Water-resistive barriers must comply with the requirements of IBC Section 1404.2.

DIVISION: 07 00 00—THERMAL AND MOISTURE PROTECTION  
Section: 07 21 00—Thermal Insulation

**REPORT HOLDER:**

RMAX®, A BUSINESS UNIT OF SIKA CORPORATION

**EVALUATION SUBJECT:**

RMAX® THERMASHEATH® TSX-8500, TSX 8510, ECOMAXci FR and ECOMAXci FR WHITE INSULATION BOARDS

**1.0 EVALUATION SCOPE****Conformance to the following requirements:**

Seal and Insulate with ENERGY STAR Program – Definitions and Testing Requirements for Residential Insulation Version 1.0.

**Properties evaluated:**

- Thermal resistance
- Surface-burning characteristics

**2.0 PURPOSE OF THIS SUPPLEMENT**

This supplement is issued to certify that the Rmax® Thermasheath® insulation board described in Sections 2.0 through 7.0 of the evaluation report (ESR-1864) has been reviewed for compliance with the applicable codes noted in Section 1.0 of the evaluation report and for the requirements set forth in Seal and Insulate with ENERGY STAR Program – Definitions and Testing Requirements for Residential Insulation Version 1.0. The Rmax® Thermasheath® insulation board covered by this supplement is classified as 'Board Insulation'.

The requirements for testing laboratory qualifications, product sampling, as well as the specific material and test standards and editions used in this evaluation are as set forth in the applicable documentation noted in Section 6.0 of the evaluation report.

**3.0 DEFINITIONS**

The following definitions are from the Definitions and Testing Requirements for Residential Insulation Version 1.0 and are applicable to the subject of this report.

**3.1 General Definitions**

**Insulation:** Any material mainly used to slow down heat flow. It may be mineral or organic, fibrous, cellular, or reflective (aluminum foil). It may be in rigid, semi-rigid, flexible, or loose-fill form.

**Residential Buildings:** Single family homes (attached or unattached), multifamily buildings with 4 units or fewer, or multifamily buildings (condominiums, apartments) with 3 stories or less in height above grade.

**3.2 Insulation Product Definitions**

**Board Insulation:** Semi-rigid insulation preformed into rectangular units having a degree of suppleness particularly related to their geometrical dimensions. Typical materials include, but are not limited to fiberglass, expanded polystyrene (EPS), extruded polystyrene (XPS), polyisocyanurate, or polyurethane. The product may or may not be faced.

**3.3 Insulation Performance Definitions**

**R-value:** The inverse of the time rate of heat flow through a body from one of its bounding surfaces to the other surface for a unit temperature difference between the two surfaces, under steady state conditions, per unit area. For the purposes of the Seal and Insulate with ENERGY STAR program, Imperial units will only be accepted [(h-ft<sup>2</sup>·°F)/Btu].

**Smoke-Development Index:** The characteristic of a material to emit smoke when exposed to flame or fire compared to red oak and inorganic cement.

**Flame-Spread Index:** The characteristic of a material to resist the spreading of flames when exposed to flame or fire compared to red oak and inorganic cement.

### 3.4 Thermal Resistance:

The Rmax<sup>®</sup> Thermasheath<sup>®</sup> insulation board has thermal resistance *R*-values as noted in Table 1 of ESR-1864.

### 3.5 Installation

**3.5.1 General:** The installation of the Rmax<sup>®</sup> Thermasheath<sup>®</sup> insulation must be in accordance with the requirements set forth in Sections 4.0 and 5.0 (as applicable) of ESR-1864. The following personal protective equipment and ventilation requirements are reprinted from the Rmax published installation instructions and are provided at the end of this report for informational purposes:

- Cutting Thermasheath produces a nuisance or irritant dust – use of a dust mask may be necessary.
- Safety glasses are always recommended when using power tools.

**3.5.2 Occupancy time after installation:** There are no specific requirements related to re-entry or re-occupancy time after installation of the insulation.

**3.5.3 Figures:** The figures shown represent general installations of the Thermasheath insulation in the following applications: above-grade wall (exterior and interior application), below-grade wall (interior application), roof deck, crawl space ceiling, below concrete floor slab, radiant floor slab, unvented cathedral ceiling, and vented and unvented attic. These figures are for illustration purposes and are not to be construed or used as construction documents.

This supplement expires concurrently with the evaluation report, reissued February 2022.



## Insulation Instructions For the Seal and Insulate with ENERGY STAR® program

### Description:

General installation instructions, warnings, limitations and warranty information for Rmax Thermasheath insulation boards are provided below. Construction diagrams within this report provide additional details based on various applications. Consult [www.rmax.com](http://www.rmax.com) for more information and complete literature, including, but not limited to, data sheets, SDS, Sales Policy, etc.

### General Installation Instructions:

- Special training and/or certification is not required. This product is designed for an easy install for both DIYs and professional contractors.
- Before beginning installation, all surfaces shall be clean and free of irregularities that will affect the placement or performance of the insulation, including, but not limited to, dirt, debris, miscellaneous fasteners or warped, defective or otherwise damaged framing.
- Installations utilizing Thermasheath must be separated from the interior side of the building by a suitable thermal barrier or ignition barrier when required. Refer to the Local Building Official for general exceptions and specific governing codes and requirements. Consult Rmax for special testing and exceptions on thicknesses of 1" or less.
- All materials installed over Thermasheath (thermal barrier, ignition barrier, furring strips, interior finishes, veneers, roof systems, etc.), must be mechanically attached through the insulation to the framing/structure according to the building code.

### Walls and Ceilings:

- Attach insulation boards to framing or other finished surface.
  - Starting at one corner/edge, install boards continuously and tightly abutted to cover entire surface.
  - Where insulation is cut to accommodate penetrations, voids and gapping should be minimized.
  - When using compatible adhesives to secure boards, apply the adhesive to the finished surface. Press/hold the board firmly until adhesive is set. Refer to adhesive manufacturer for application recommendations and proper installation techniques.
  - When using mechanical fasteners to secure boards, use fasteners with sufficient length to penetrate framing or other finished surface (minimum  $\frac{3}{4}$ " into wood or minimum 29/64" into steel). Use a minimum of 8 fasteners, spaced evenly throughout the board.
  - Where multiple rows or layers of insulation exist, stagger joints.
- When Thermasheath is being used as the vapor retarder, water-resistive barrier (WRB) and/or the air barrier, the following measures should be taken to ensure a complete barrier:
  - All insulation board joints, as well as, any breaks or other damage to the face in the insulation shall be sealed with a pressure sensitive tape, such as Rmax R-SEAL 3000 or R-SEAL Construction Tape.
    - All perimeter edges, transitions and fenestration shall be sealed to the exterior face of the Thermasheath with appropriate flashing, including, but not limited to, exposed foam edges, wall to floor and wall to roof transitions, windows, doors, etc.



## **Insulation Instructions For the Seal and Insulate with ENERGY STAR® program**

- All penetrations made through the exterior plane of the WRB and/or air barrier shall be sealed using tape, flashing, caulk or other water/air sealing method.

NOTE: When Rmax Thermasheath is not the primary air barrier, ENERGY STAR requires air sealing throughout the envelope by other means.

- Refer to individual application details for more specific instructions.
  - For Exterior Applications see Details: Stud Wall Constructions Siding 01, Stud Wall Construction (Brick Veneer) 02, Masonry Wall Construction (Veneer) 03, Re-Siding Construction 04.
  - For Interior Applications see Details: Masonry Wall Construction 05, Stud Wall & Vaulted Ceilings Construction 06, Attic Knee Wall & Ceiling Construction 07, Below Grade Wall Construction 10, Ceiling Crawl Space Construction 11

### Floors and Below Grade:

- Attach insulation boards to finished surface.
  - Install Thermasheath over specially prepared base of crushed stone for slab on grade constructions or on existing slab for floor and radiant floor slab constructions.
  - Starting at one corner/edge, install boards continuously and tightly abutted to cover entire surface.
  - Where insulation is cut to accommodate penetrations, voids and gapping should be minimized.
- Refer to individual application details for more specific instructions.
  - See Details: Slab on Grade Construction 12, Floor Construction 13, Radiant Floors Slab Construction 14

### Roofs:

- Attach insulation boards to suitable roof deck (tongue-and-groove timber, plywood, or metal deck).
  - Secure boards to roof deck with enough fasteners to hold it in place until the nailing surface or roof cover system is attached through the insulation to the deck.
  - Starting at one corner/edge, install boards continuously and tightly abutted to cover entire surface.
  - Where multiple rows or layers of insulation exist, stagger joints.
  - Where insulation is cut to accommodate penetrations, voids and gapping should be minimized.
  - When using compatible adhesives to secure boards, apply the adhesive per the manufacturer's recommendations.
  - When using mechanical fasteners to secure boards, use screw and plate type fasteners with sufficient length to penetrate the deck (minimum 1" into wood or minimum 3/4" into steel).
- Rmax strongly recommends the decision to use or not use a vapor retarder in any insulated roofing assembly, as well as, its location within the system, be guided by the recommendations of the National Roofing Contractors Association (NRCA).
- Refer to individual application details for more specific instructions.
  - See Details : Standing Seam Metal Roof 08, Shingle Roof Construction 09





## Insulation Instructions For the Seal and Insulate with ENERGY STAR® program

### Limitations:

- Thermasheath should not be used as commercial roof insulation directly under membrane systems.
- Thermasheath is not a structural panel and must not be used as a nailing base for any other building products. The structure must be properly braced for lateral loads and uplift according to the requirements of the local building codes.
- In “very heavy” termite infestation probability areas, except where permitted by code, boards shall not be installed on the exterior face or under interior or exterior foundation walls or slab foundations located below grade, and the clearance between insulation boards installed above grade and exposed earth shall be at least 6 inches (152 mm). Consult the Local Building Official for specific governing codes and requirements.

### Warnings:

- Polyisocyanurate foam is an organic material which will burn when exposed to an ignition source of sufficient heat and intensity and may contribute to flames spreading. Boards must not be in direct contact with hot objects requiring a certain amount of clearance. Refer to equipment/fixture rating for guidance.

### Safety:

- Cutting Thermasheath produces a nuisance or irritant dust – use of a dust mask may be necessary.
- Safety glasses are always recommended when using power tools.
- Proper ventilation should be provided to minimize airborne dust and fumes if using construction adhesives.

### Warranty:

- See Rmax “Sales Policy” for warranty conditions, Rmax does not assume any responsibility or liability for the performance of any products other than those manufactured by Rmax. **NOTE: All Rmax products must be tarped, placed on skids and kept dry before and throughout construction until proper sealing techniques are employed.**

15-MINUTE  
THERMAL  
BARRIER

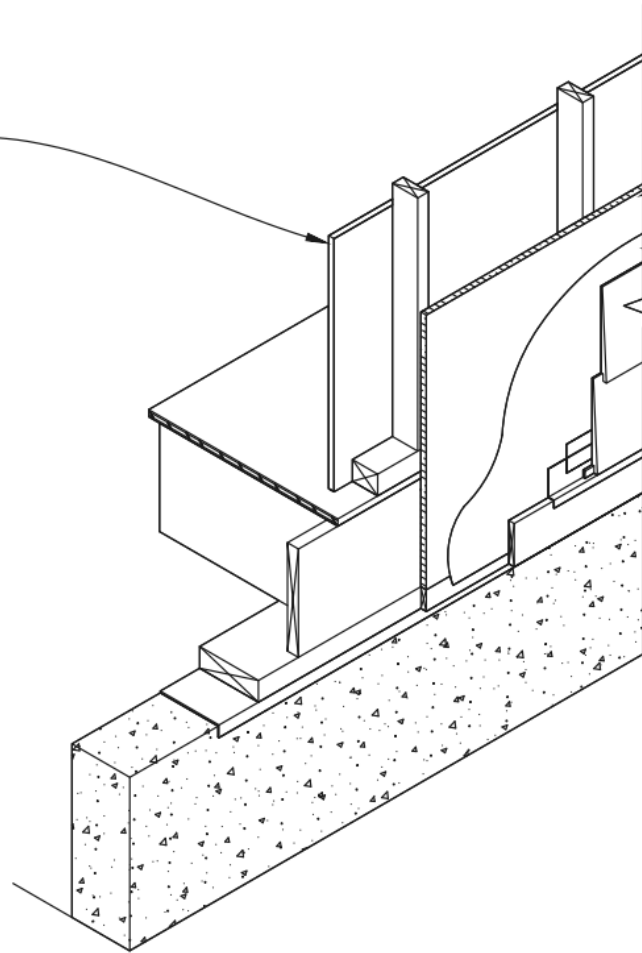

THERMASHEATH

WRB  
(if required)

**Notes:**

1. Veneer shown is lap siding. Other veneers, such as stucco and various siding materials - aluminum, vinyl, fiber cement, wood and wood based products - are also acceptable. For stucco systems, the secondary barrier is required over the Thermasheath prior to attaching the metal lathe.
2. Thermasheath insulation panels shall be secured to the studs using bugle-head screws, galvanized roofing nails, or minimum  $\frac{3}{4}$ " cap nails. A quality grade construction adhesive may also be used to secure the Thermasheath. The veneer must be mechanically attached through the Thermasheath to the studs.
3. Where a separate water resistive barrier (WRB) is not included, the joints of the Thermasheath shall be sealed using a pressure sensitive aluminum tape such as Rmax R-SEAL 3000 or R-SEAL Construction Tape.

## Stud Wall Construction (Siding) | 01

Thermasheath Exterior Application | A1.00



Rmax  
13524 Welch Road  
Dallas, TX 75244  
Phone: (972) 387-4500  
Web Site: [www.rmax.com](http://www.rmax.com)

(800) 845-4455 (Eastern)  
(800) 527-0890 (Central)  
(800) 762-9462 (Western)  
Email: [Rmax@rmax.com](mailto:Rmax@rmax.com)

Title: THERMASHEATH® DETAIL  
Reference Data Sheet for Additional Information

Date:  
05/01/2020

Scale:  
NTS

Sheet:  
A1.00

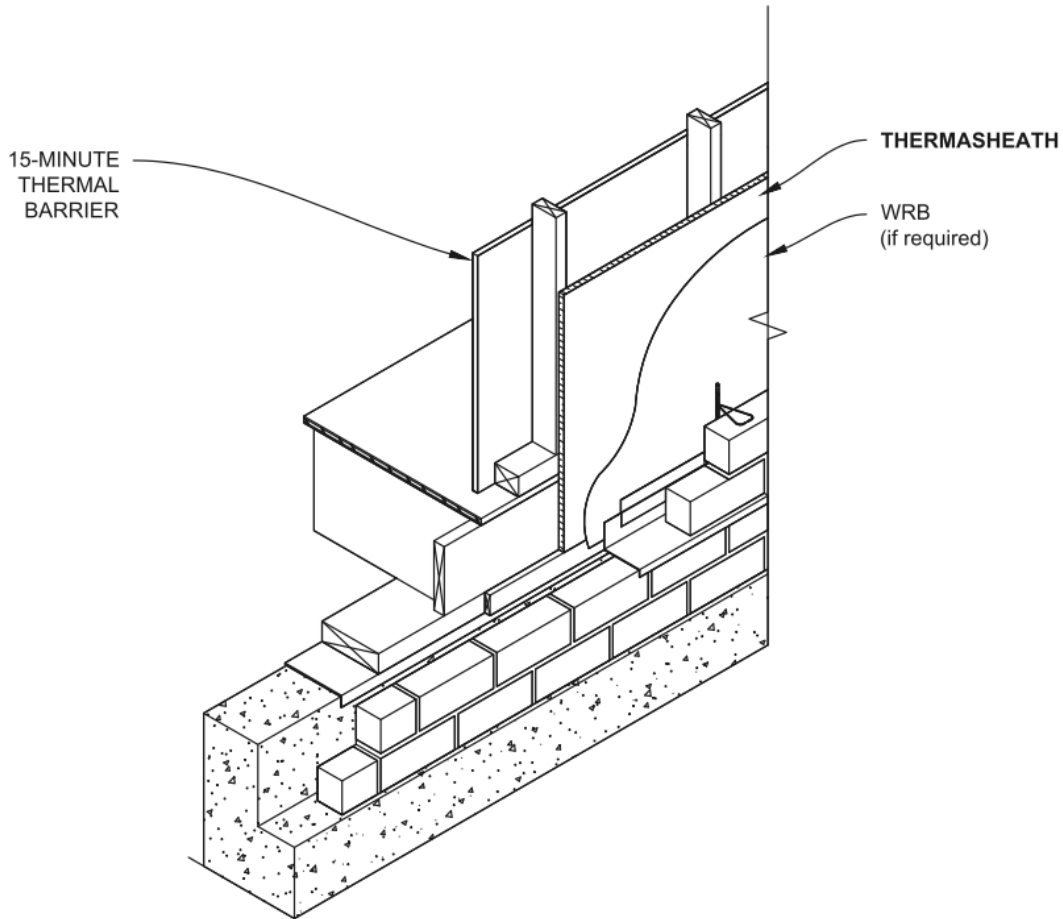

**Notes:**

1. Veneer shown is brick. Other veneers - artificial stone and natural stone - are also acceptable.
2. Thermasheath panels shall be secured to the studs using bungle-head screws, galvanized roofing nails, or minimum 3/4" cap nails, or simply cut to fit tightly between existing wall ties. Proper air space must be maintained between the face of the insulation and the veneer.
3. Where a separate water resistive barrier (WRB) is not included, the joints of the Thermasheath shall be sealed using a pressure sensitive aluminum tape such as Rmax R-SEAL 3000 or R-SEAL Construction Tape.

**Stud Wall Construction (Brick Veneer) | 02**  
 Thermasheath Exterior Application | A1.00

	Rmax 13524 Welch Road Dallas, TX 75244 Phone: (972) 387-4500 Web Site: www.rmax.com	(800) 845-4455 (Eastern) (800) 527-0890 (Central) (800) 762-9462 (Western) Email: Rmax@rmax.com	Title: THERMASHEATH®DETAIL Reference Data Sheet for Additional Information		
	Date: 05/01/2020	Scale: NTS	Sheet: A1.00		

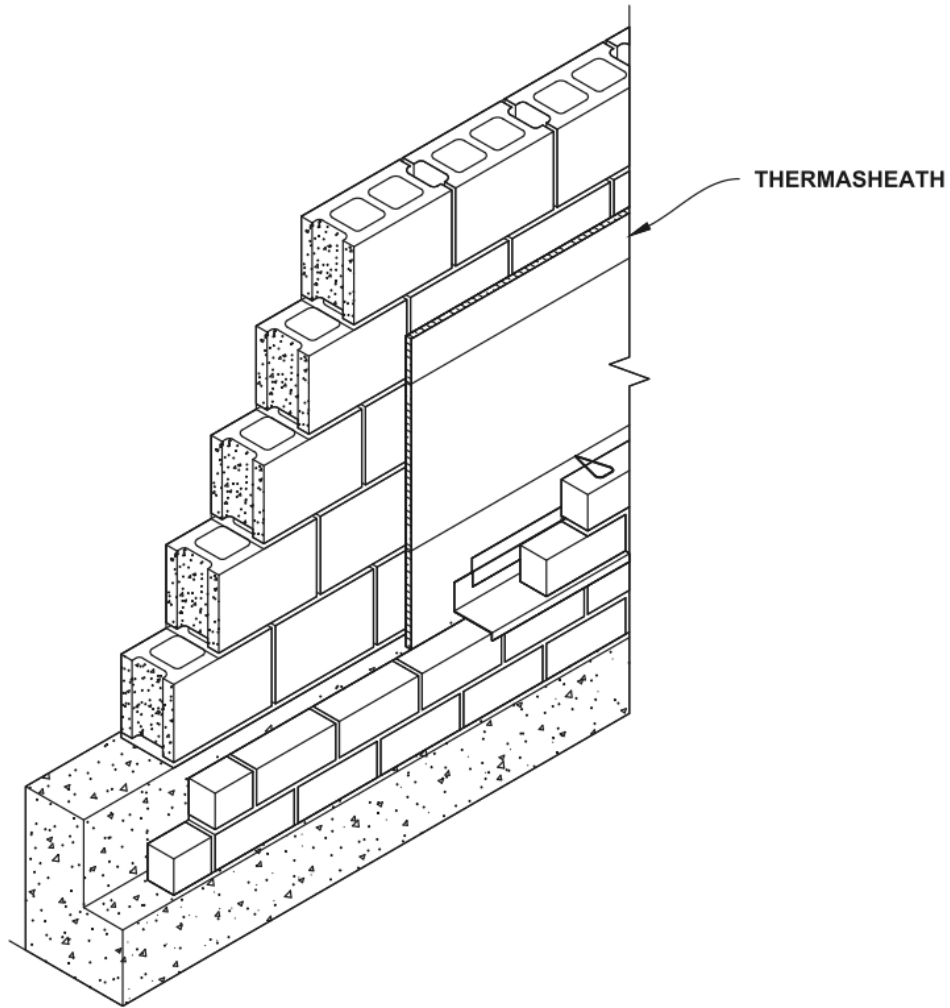

Notes:

1. Veneer shown is brick. Other veneers - artificial stone and natural stone - are also acceptable.
3. Masonry/block wall shall be adequately waterproofed according to local requirements and building design.
4. Thermasheath panels shall be secured to the dry face of concrete or CMU walls with a quality grade construction adhesive or simply cut to fit tightly between existing wall ties. Proper air space must be maintained between the face of the insulation and the veneer.

## Masonry Wall Construction (Veneer) | 03

Thermasheath Exterior Application | A1.00



Rmax  
 13524 Welch Road  
 Dallas, TX 75244  
 Phone: (972) 387-4500  
 Web Site: www.rmax.com

(800) 845-4455 (Eastern)  
 (800) 527-0890 (Central)  
 (800) 762-9462 (Western)  
 Email: Rmax@rmax.com

Title: THERMASHEATH® DETAIL  
 Reference Data Sheet for Additional Information

Date:  
 05/01/2020

Scale:  
 NTS

Sheet:  
 A1.00

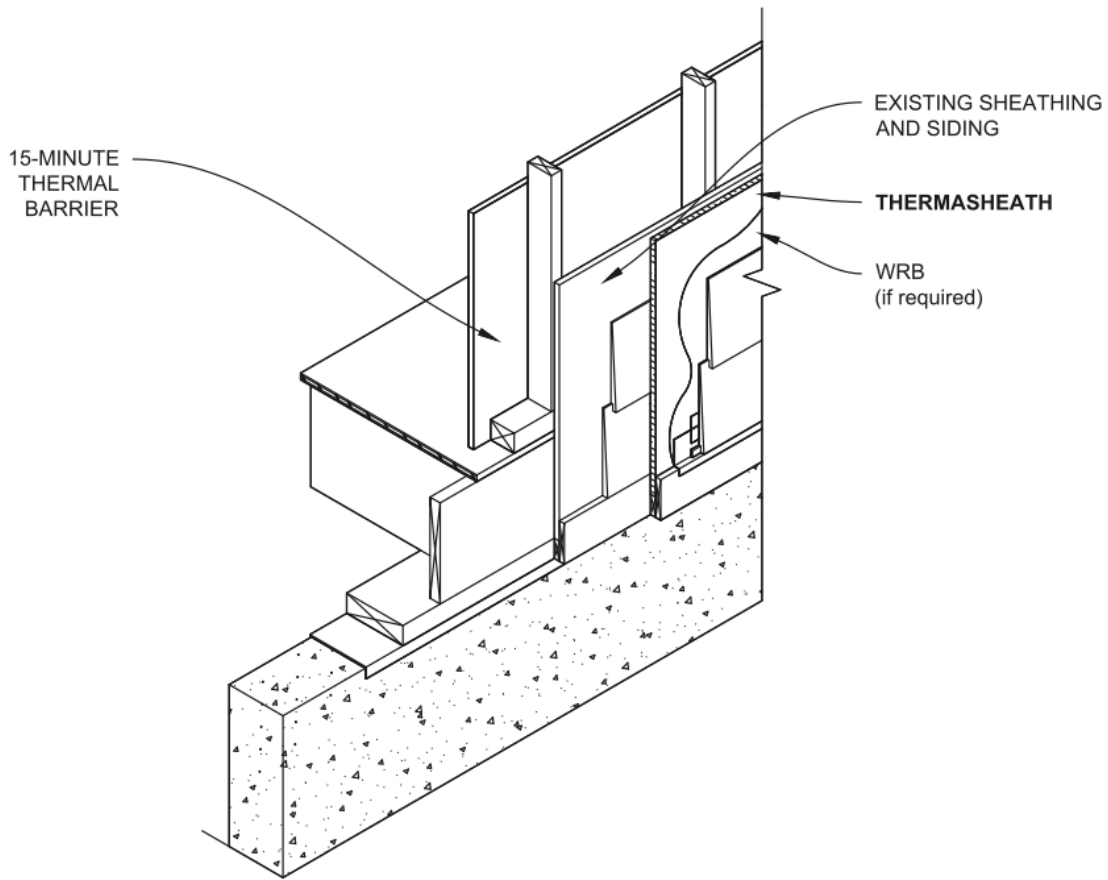

**Notes:**

1. Veneer shown is lap siding. Other veneers - stucco and various siding materials, such as aluminum, vinyl, fiber cement, wood and wood based products - are also acceptable. For stucco systems, the secondary barrier is required over the Thermasheath prior to attaching the metal lathe.
2. Thermasheath insulation panels shall be secured with galvanized nails of sufficient length to penetrate the old sidings, sheathings below and at least one inch into the existing wall studs. Prior to installation, ensure that the existing siding is sound and solidly attached.
3. Where a secondary water resistive barrier (WRB) is not included, the joints of the Thermasheath shall be sealed using a pressure sensitive aluminum tape such as Rmax R-SEAL 3000 or R-SEAL Construction Tape.

**Re-Siding Construction | 04**  
Thermasheath Exterior Application | A1.00



Rmax  
13524 Welch Road  
Dallas, TX 75244  
Phone: (972) 387-4500  
Web Site: www.rmax.com

(800) 845-4455 (Eastern)  
(800) 527-0890 (Central)  
(800) 762-9462 (Western)  
Email: Rmax@rmax.com

Title: THERMASHEATH® DETAIL  
Reference Data Sheet for Additional Information

Date:  
05/01/2020

Scale:  
NTS

Sheet:  
A1.00

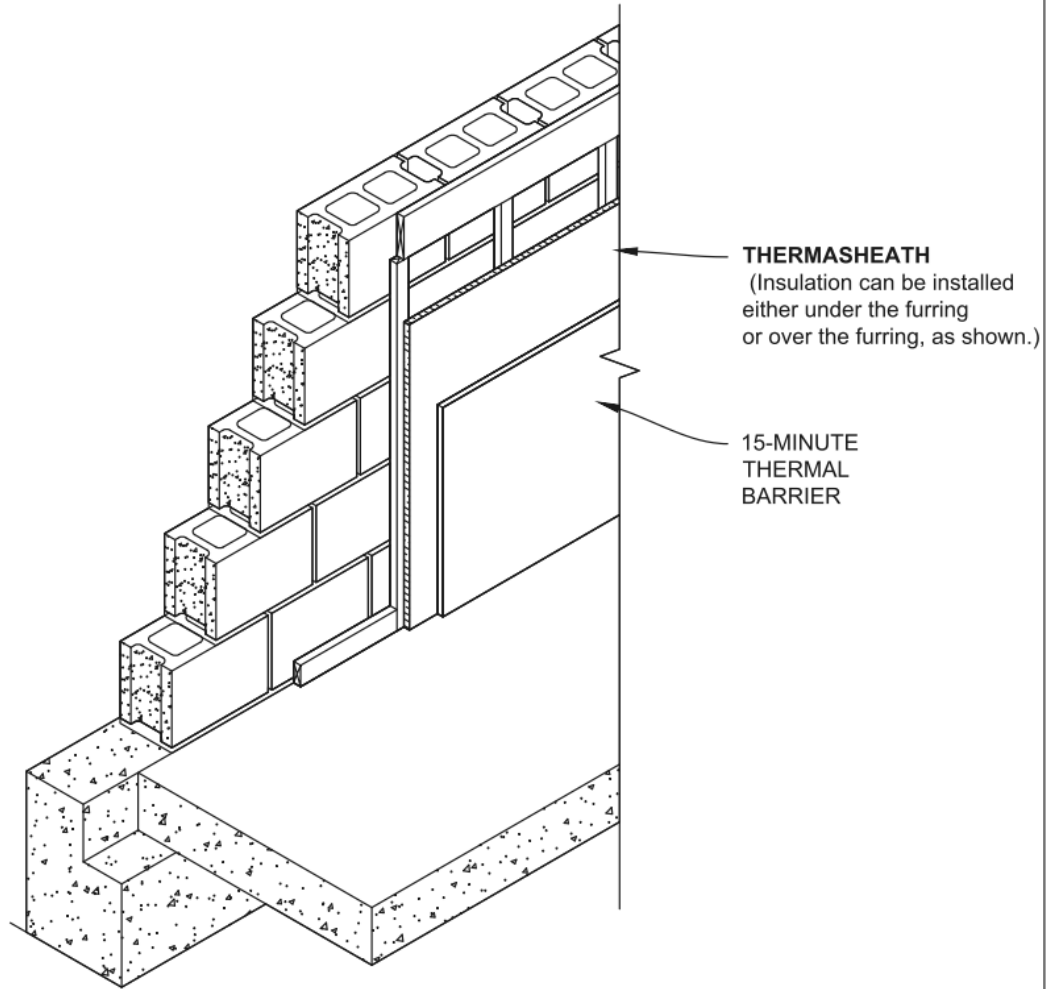

Notes:

1. Thermasheath insulation panels shall be secured to the furring using bugle-head screws, galvanized roofing nails, or minimum  $\frac{3}{4}$ " cap nails. When Thermasheath is installed under the furring, adhere panels directly to the masonry/ brick wall.
2. Masonry/block wall shall be adequately waterproofed according to local requirements and building design.

## Masonry Wall Construction | 05

### Thermasheath Interior Application | A1.00



Rmax  
 13524 Welch Road  
 Dallas, TX 75244  
 Phone: (972) 387-4500  
 Web Site: www.rmax.com

(800) 845-4455 (Eastern)  
 (800) 527-0890 (Central)  
 (800) 762-9462 (Western)  
 Email: Rmax@rmax.com

Title: THERMASHEATH® DETAIL  
 Reference Data Sheet for Additional Information

Date:  
 05/01/2020

Scale:  
 NTS

Sheet:  
 A1.00

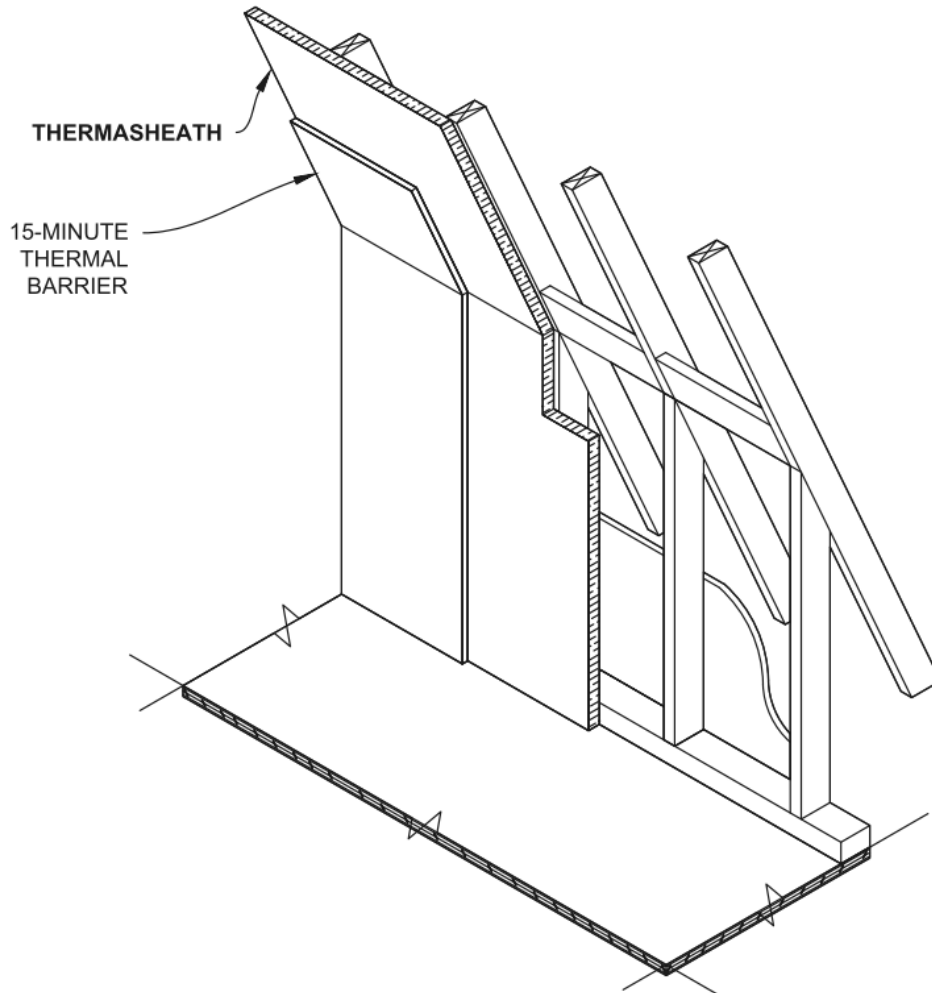

Notes:

1. Refer to local building codes for requirements on proper ventilation.
2. Thermasheath insulation panels shall be secured to the rafters/ studs using bugle-head screws, galvanized roofing nails, or minimum  $\frac{3}{4}$ " cap nails. A quality grade construction adhesive may also be used to secure the Thermasheath.

## Stud Wall & Vaulted Ceiling Construction | 06

Thermasheath Interior Application | A1.00



Rmax  
 13524 Welch Road  
 Dallas, TX 75244  
 Phone: (972) 387-4500  
 Web Site: [www.rmax.com](http://www.rmax.com)

(800) 845-4455 (Eastern)  
 (800) 527-0890 (Central)  
 (800) 762-9462 (Western)  
 Email: [Rmax@rmax.com](mailto:Rmax@rmax.com)

Title: THERMASHEATH® DETAIL  
 Reference Data Sheet for Additional Information

Date:  
 05/01/2020

Scale:  
 NTS

Sheet:  
 A1.00

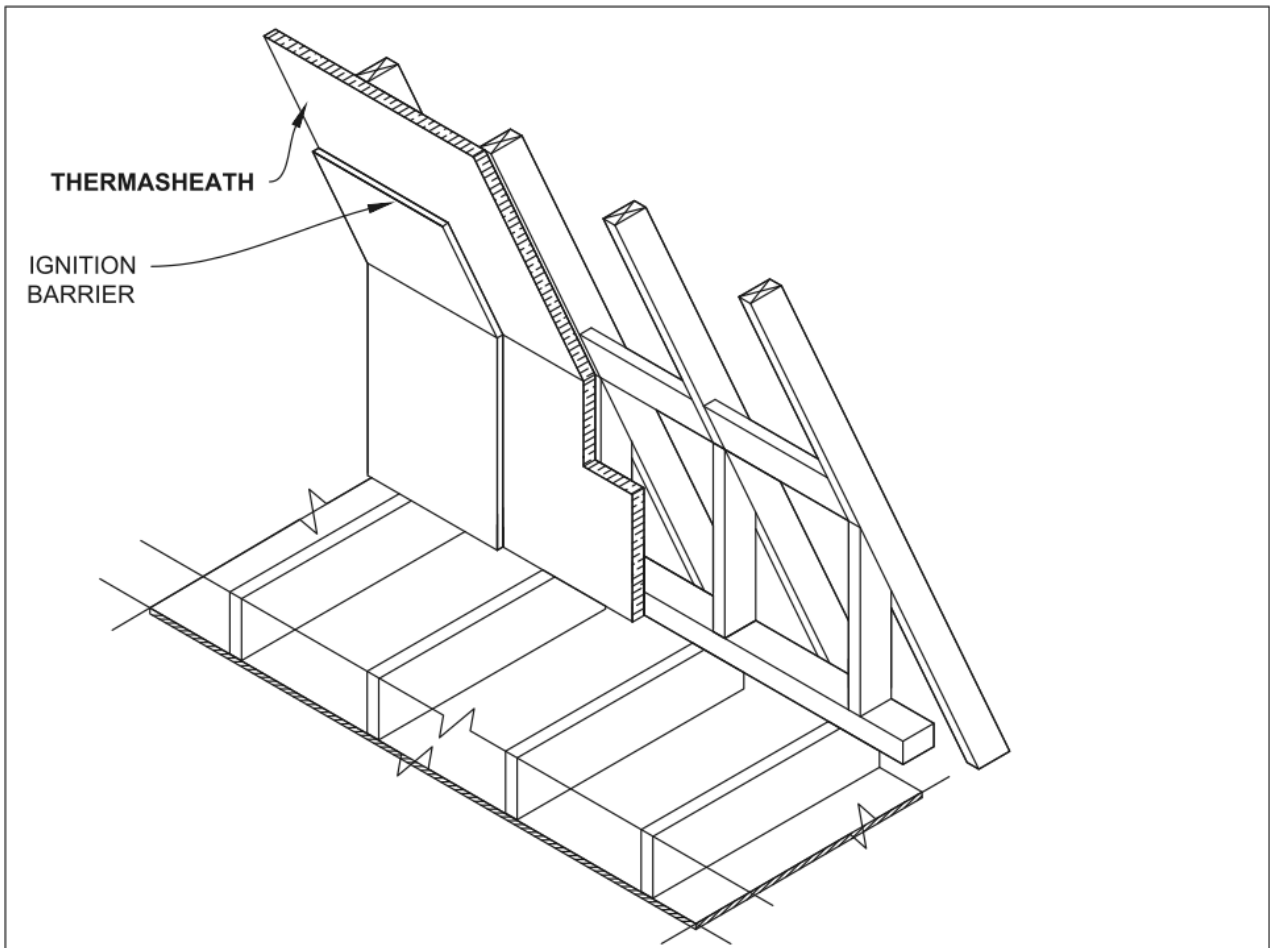

Notes:

1. Refer to local building codes for requirements on proper ventilation.
2. Thermasheath insulation panels shall be secured to the studs/ rafters using bugle-head screws, galvanized roofing nails, or common nails driven through cap washers. A quality grade construction adhesive may also be used to secure the Thermasheath.
3. Where the Thermasheath is being used as a vapor retarder, the panel joints shall be sealed using a pressure sensitive tape such as Rmax R-SEAL 3000 or R-SEAL Construction Tape. Otherwise, a secondary vapor retarder may be required per local Building Codes.

## Attic Knee Wall & Ceiling Construction | 07

Thermasheath Interior Application | A1.00

	Rmax 13524 Welch Road Dallas, TX 75244 Phone: (972) 387-4500 Web Site: <a href="http://www.rmax.com">www.rmax.com</a>	(800) 845-4455 (Eastern) (800) 527-0890 (Central) (800) 762-9462 (Western) Email: <a href="mailto:Rmax@rmax.com">Rmax@rmax.com</a>	Title: THERMASHEATH®DETAIL Reference Data Sheet for Additional Information		
	Date: 05/01/2020	Scale: NTS	Sheet: A1.00		



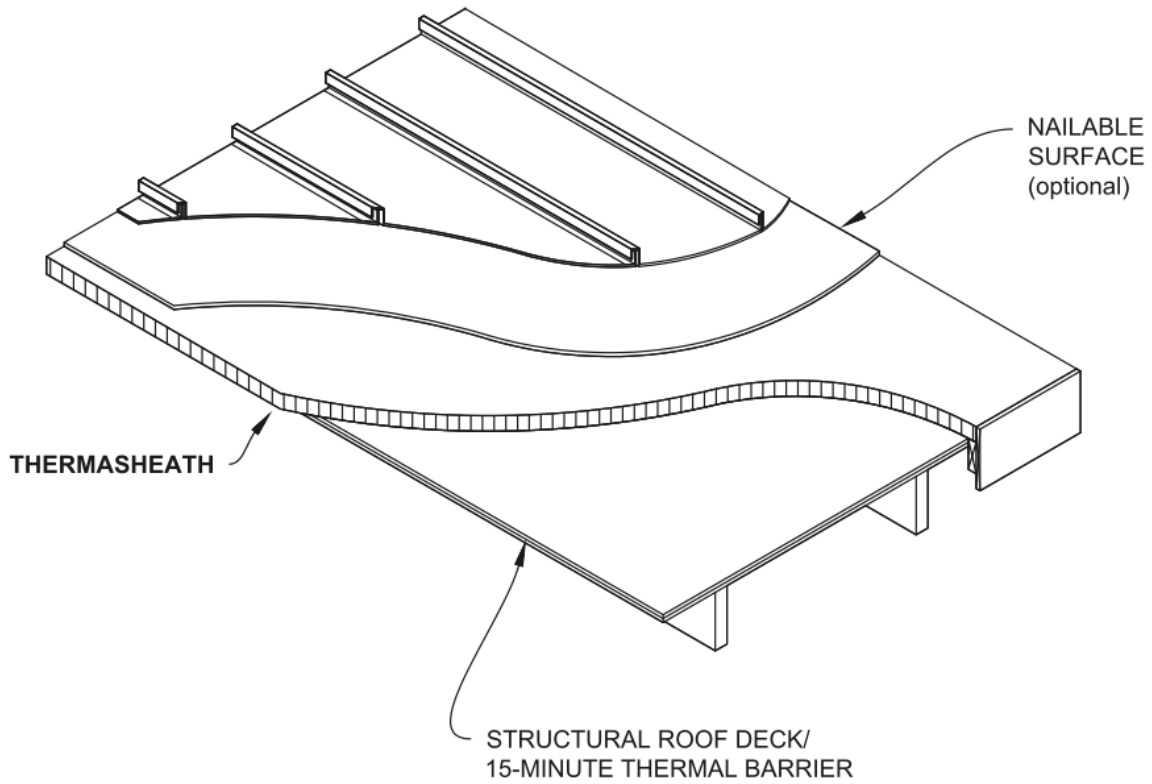

**Standing Seam Metal Roof Construction | 08**  
Thermasheath Exterior Application | A1.00



Rmax  
13524 Welch Road  
Dallas, TX 75244  
Phone: (972) 387-4500  
Web Site: [www.rmax.com](http://www.rmax.com)

(800) 845-4455 (Eastern)  
(800) 527-0890 (Central)  
(800) 762-9462 (Western)  
Email: [Rmax@rmax.com](mailto:Rmax@rmax.com)

Title: THERMASHEATH®DETAIL  
Reference Data Sheet for Additional Information

Date:  
05/01/2020

Scale:  
NTS

Sheet:  
A1.00

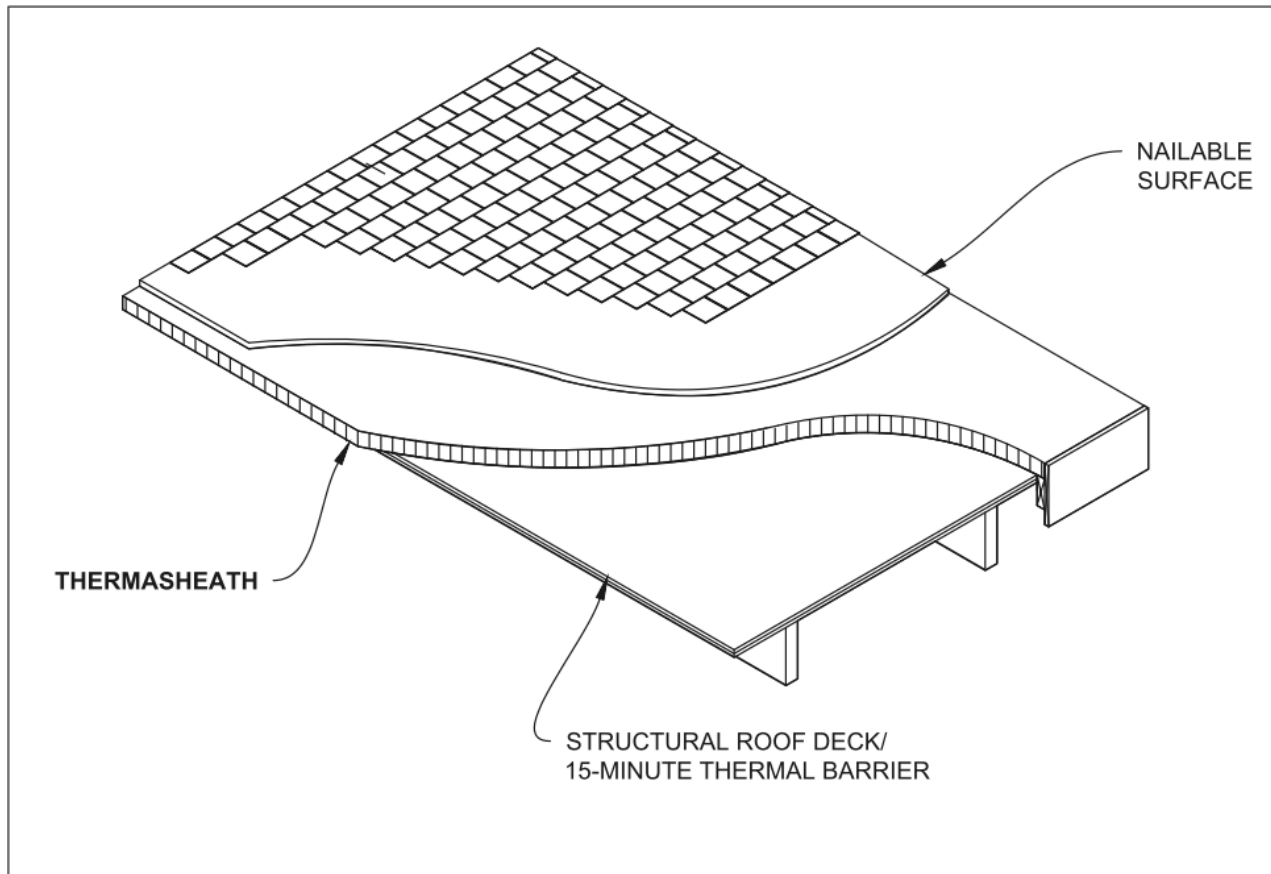

Notes:

1. Roof cover shown is asphalt shingles. Other covers - wood shingles and concrete or clay tiles - are also acceptable. Consult roof cover manufacturer for above deck roof ventilation requirements.

**Shingle Roof Construction | 09**  
**THERMASHEATH Exterior Application | A1.00**

	Rmax 13524 Welch Road Dallas, TX 75244 Phone: (972) 387-4500 Web Site: www.rmax.com	(800) 845-4455 (Eastern) (800) 527-0890 (Central) (800) 762-9462 (Western) Email: Rmax@rmax.com	Title: THERMASHEATH® DETAIL Reference Data Sheet for Additional Information		
			Date: 05/01/2020	Scale: NTS	Sheet: A1.00

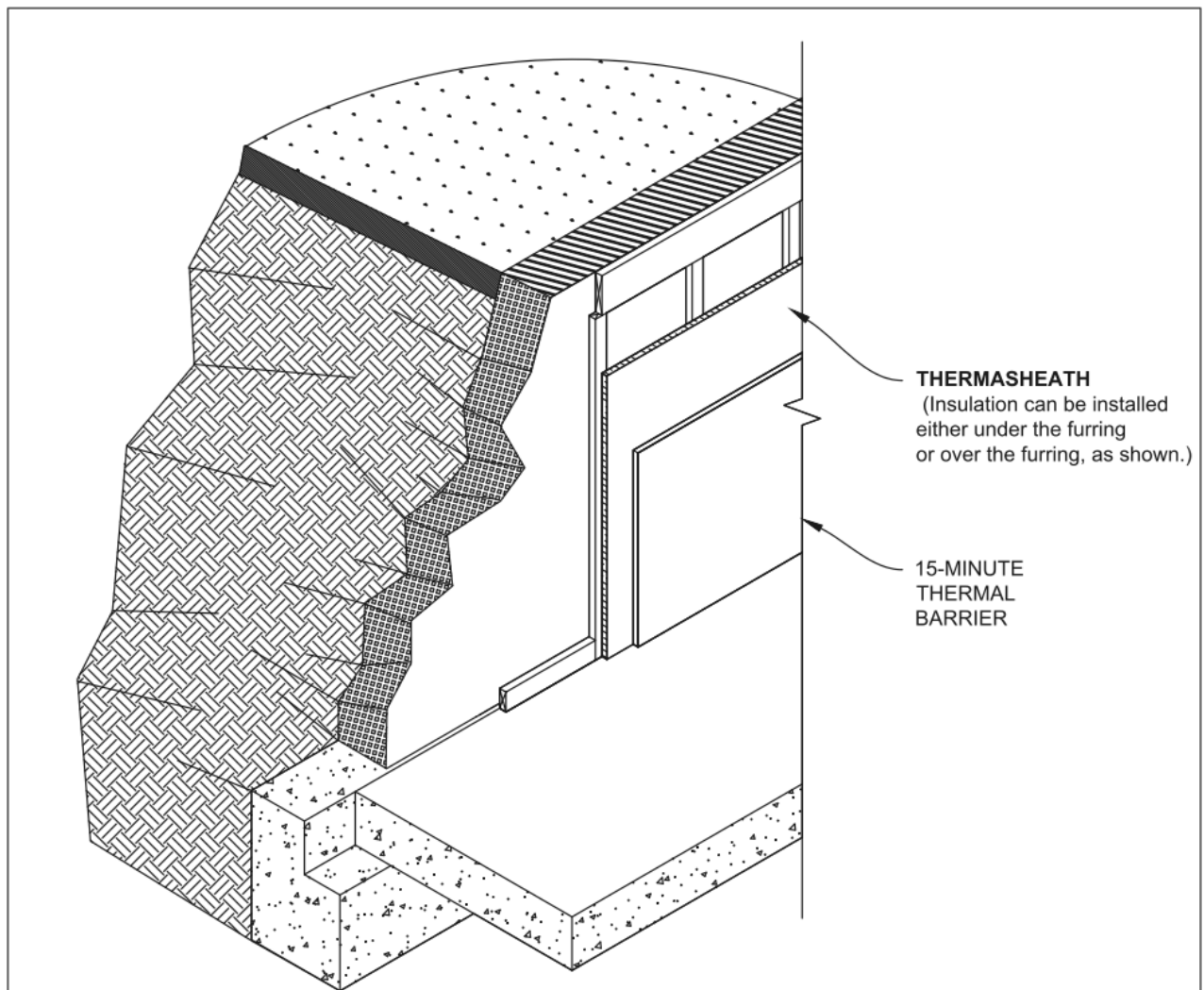

**THERMASHEATH**  
 (Insulation can be installed either under the furring or over the furring, as shown.)

**15-MINUTE THERMAL BARRIER**

**Notes:**

1. Thermasheath insulation panels shall be secured to the furring using bugle-head screws, galvanized roofing nails, or minimum 3/4" cap nails. A quality grade construction adhesive may also be used to secure the Thermasheath.
2. Masonry/block wall shall be adequately waterproofed according to local requirements and building design.

## Below Grade Wall Construction | 10

### Thermasheath Interior Application | A1.00



Rmax  
 13524 Welch Road  
 Dallas, TX 75244  
 Phone: (972) 387-4500  
 Web Site: www.rmax.com

(800) 845-4455 (Eastern)  
 (800) 527-0890 (Central)  
 (800) 762-9462 (Western)  
 Email: Rmax@rmax.com

Title: THERMASHEATH® DETAIL  
 Reference Data Sheet for Additional Information

Date:  
 05/01/2020

Scale:  
 NTS

Sheet:  
 A1.00

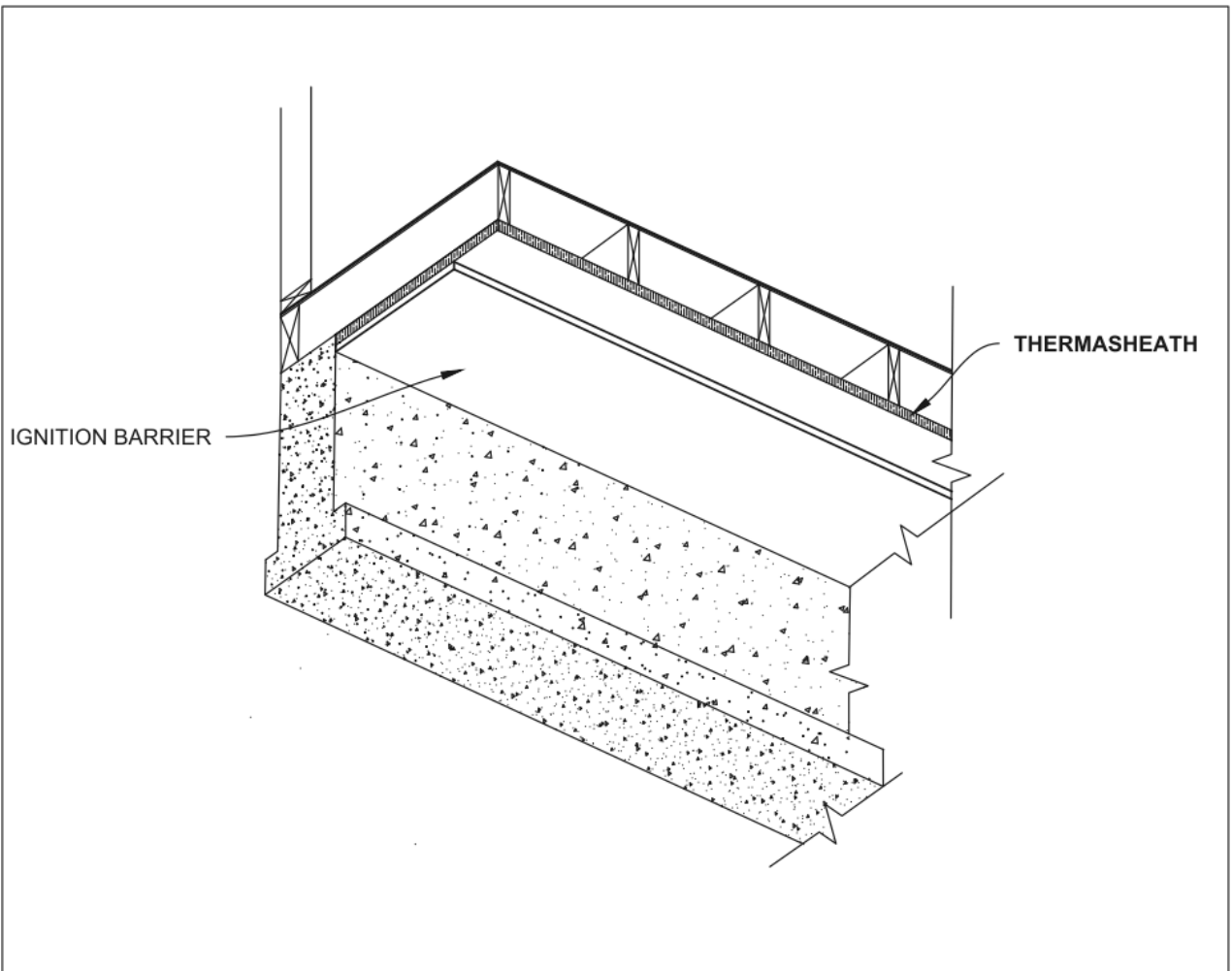

Notes:

1. Refer to local building codes for requirements on proper ventilation and bracing.
2. Thermasheath insulation panels shall be secured to the framing using bugle-head screws, galvanized roofing nails, or minimum 3/4" cap nails. A quality grade construction adhesive may also be used to secure the Thermasheath.

## Ceiling Crawl Space Construction | 11

Thermasheath | A1.00



Rmax  
 13524 Welch Road  
 Dallas, TX 75244  
 Phone: (972) 387-4500  
 Web Site: www.rmax.com

(800) 845-4455 (Eastern)  
 (800) 527-0890 (Central)  
 (800) 762-9462 (Western)  
 Email: Rmax@rmax.com

Title: THERMASHEATH®DETAIL  
 Reference Data Sheet for Additional Information

Date:  
 05/01/2020

Scale:  
 NTS

Sheet:  
 A1.00

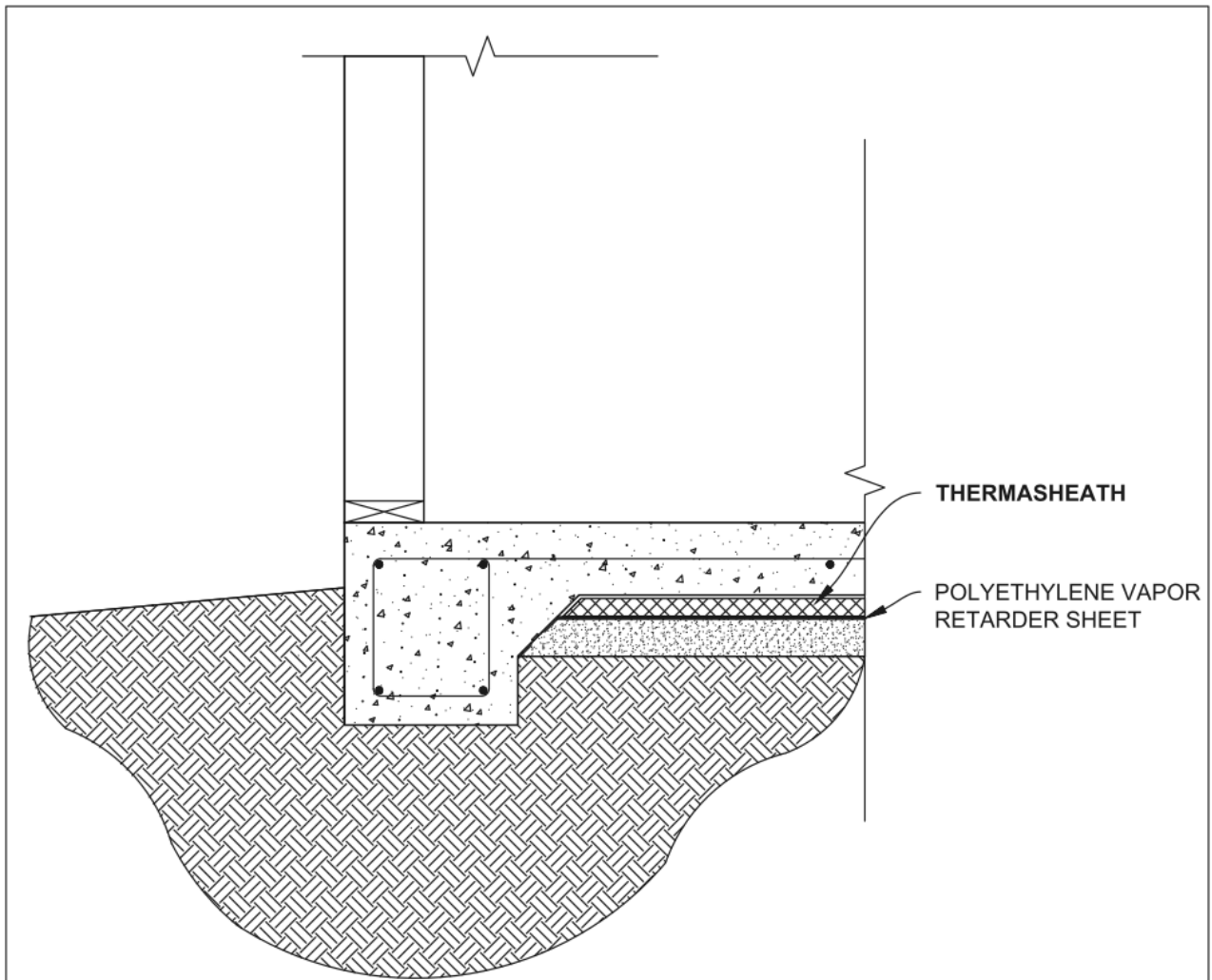

Notes:

1. Thermasheath insulation panels are simply laid over the specially prepared base of crushed stone, sand or other material that is spread for leveling.
2. Exact placement of the polyethylene vapor barrier is up the building designer and local code requirements.

## Slab-on-Grade Construction | 12

Thermasheath | A1.00



Rmax  
 13524 Welch Road  
 Dallas, TX 75244  
 Phone: (972) 387-4500  
 Web Site: www.rmax.com

(800) 845-4455 (Eastern)  
 (800) 527-0890 (Central)  
 (800) 762-9462 (Western)  
 Email: Rmax@rmax.com

Title: THERMASHEATH® DETAIL  
 Reference Data Sheet for Additional Information

Date:  
 05/01/2020

Scale:  
 NTS

Sheet:  
 A1.00

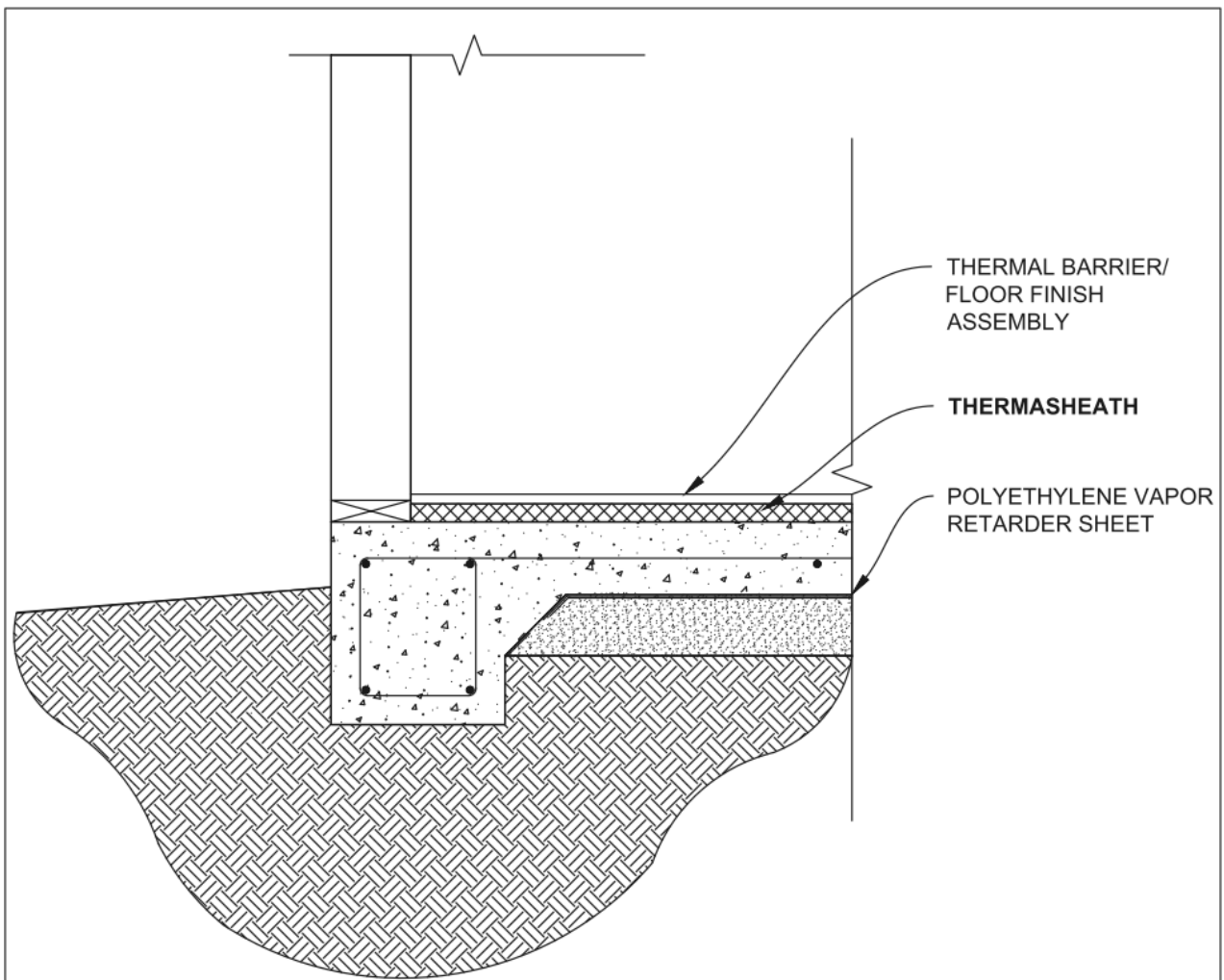

Notes:

1. Thermasheath insulation panels are simply laid over the existing slab.
2. Refer to local building codes for requirements on confined spaces with exposed foam plastic where applicable.

Floor Construction | 13

Thermasheath | A1.00



Rmax  
 13524 Welch Road  
 Dallas, TX 75244  
 Phone: (972) 387-4500  
 Web Site: www.rmax.com

(800) 845-4455 (Eastern)  
 (800) 527-0890 (Central)  
 (800) 762-9462 (Western)  
 Email: Rmax@rmax.com

Title: THERMASHEATH®DETAIL  
 Reference Data Sheet for Additional Information

Date:  
 05/01/2020

Scale:  
 NTS

Sheet:  
 A1.00

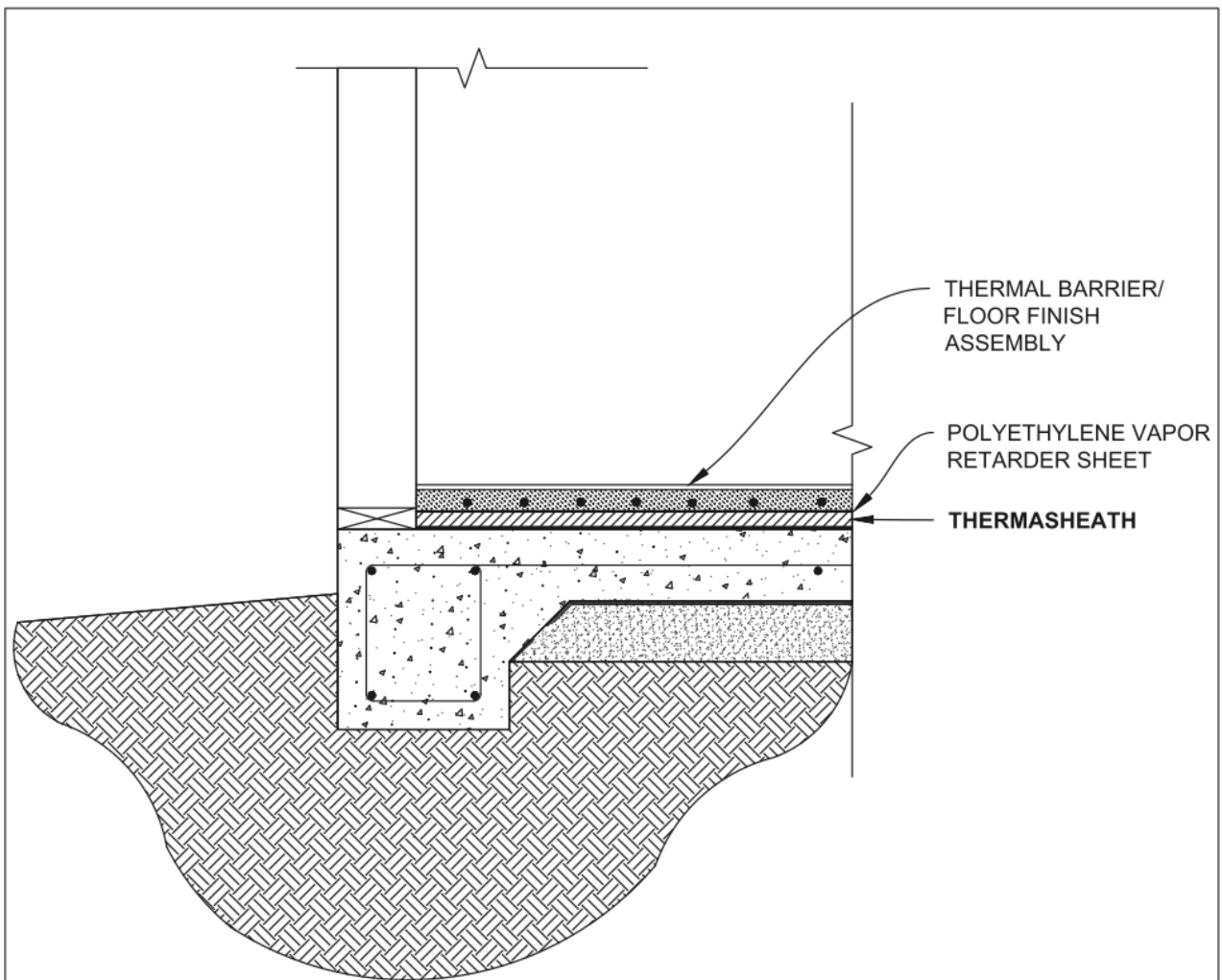

Notes:

1. Thermasheath insulation panels are simply laid over the existing slab.
2. Exact placement of the polyethylene vapor barrier is up the building designer and local code requirements.

## Radiant Floor Slab Construction | 14

Thermasheath | A1.00



Rmax  
 13524 Welch Road  
 Dallas, TX 75244  
 Phone: (972) 387-4500  
 Web Site: www.rmax.com

(800) 845-4455 (Eastern)  
 (800) 527-0890 (Central)  
 (800) 762-9462 (Western)  
 Email: Rmax@rmax.com

Title: THERMASHEATH® DETAIL  
 Reference Data Sheet for Additional Information

Date:  
 05/01/2020

Scale:  
 NTS

Sheet:  
 A1.00