



**HARDING
S T E E L**



15 (typ.)

50

10 (typ.)



CARPARX™ ST-3

Harding Steel's unique CARPARX™ ST-3 subterranean parking system allows two conventional vehicles to be parked in secure, below-grade parking locations while allowing a third vehicle to be parked on the surface space above the machine. The ST3 features a large, single-acting scissors lift assembly powered by four hydraulic RAM cylinders.

The CARPARX ST-3 system is designed to be compatible with the needs of custom single-family homes or for multi-family dwellings where it is not possible to provide valet parking service. The design allows for up to three separate households to independently park and retrieve their own vehicle from the system without moving any other vehicle. Design features include flat, oversized vehicle platforms that are easy to park on. There are no trip hazards and the systems are perfectly flush to the garage floor surface. All lifting devices, structural members, and hydraulic components are completely below ground and out of the way. There are no gaps around the edges of the pit, and when the lifts are in the down position, the garage has a perfectly flat, solid, trip-free surface.

The ST-3 requires a below grade pit structure that is built to Harding Steel's specifications. Adequate pit depth and ceiling clearance is necessary for these systems. The ST-3C model is configured for outdoor application and is custom fabricated for site-specific needs. All Harding Steel inground parking systems are built-to-order and can be customized to meet the unique needs of each application.



CARPARX[™]
ST-3

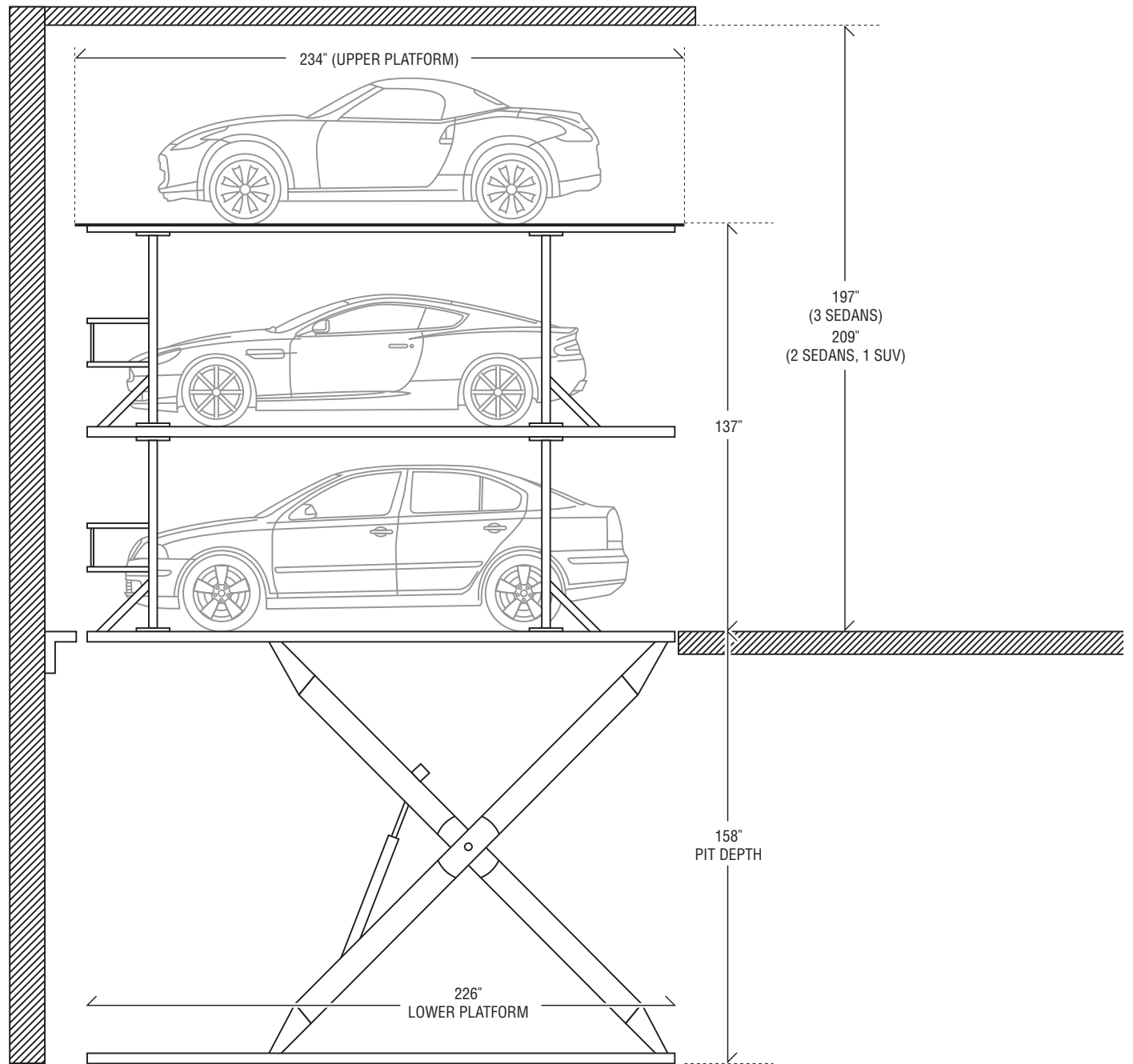
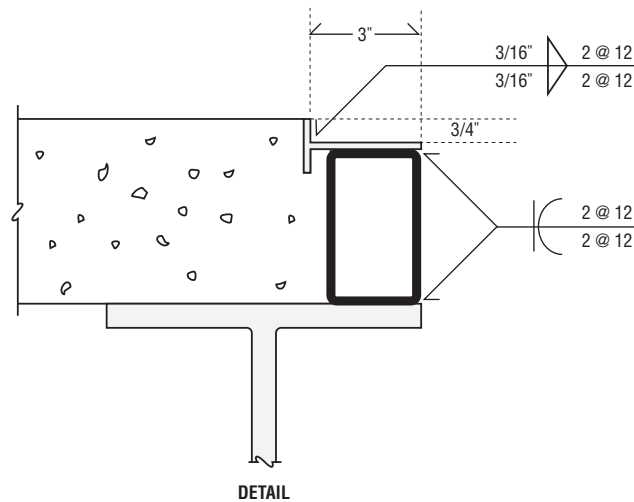
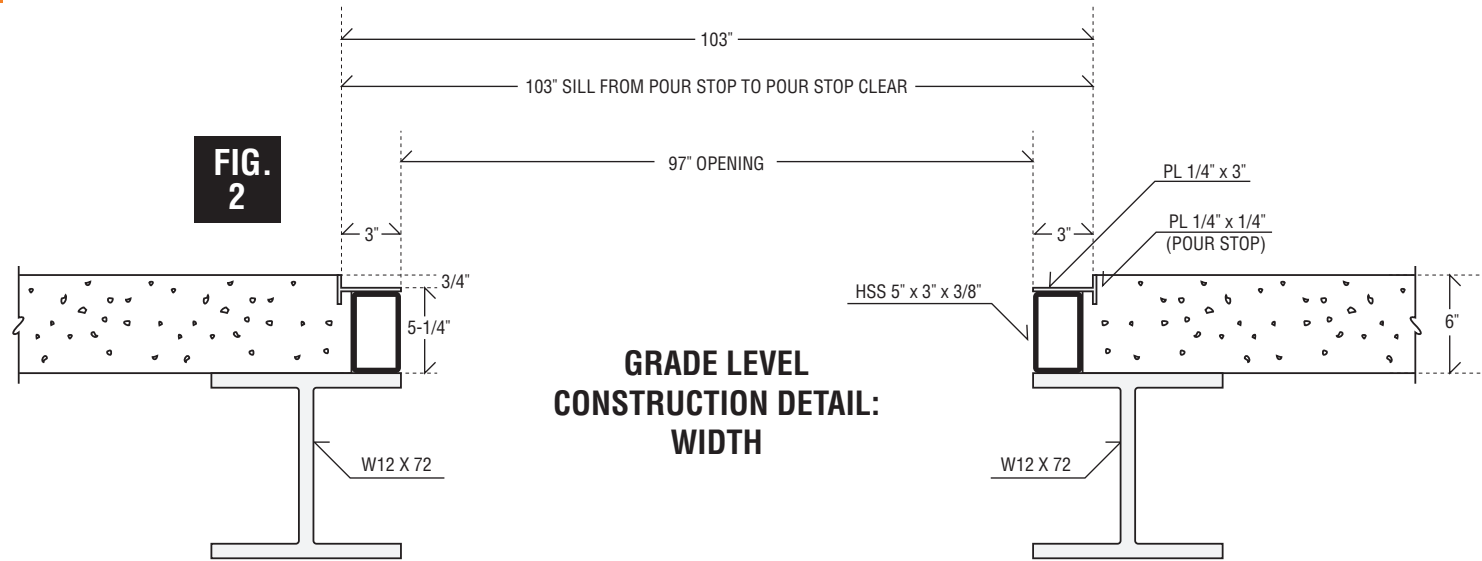
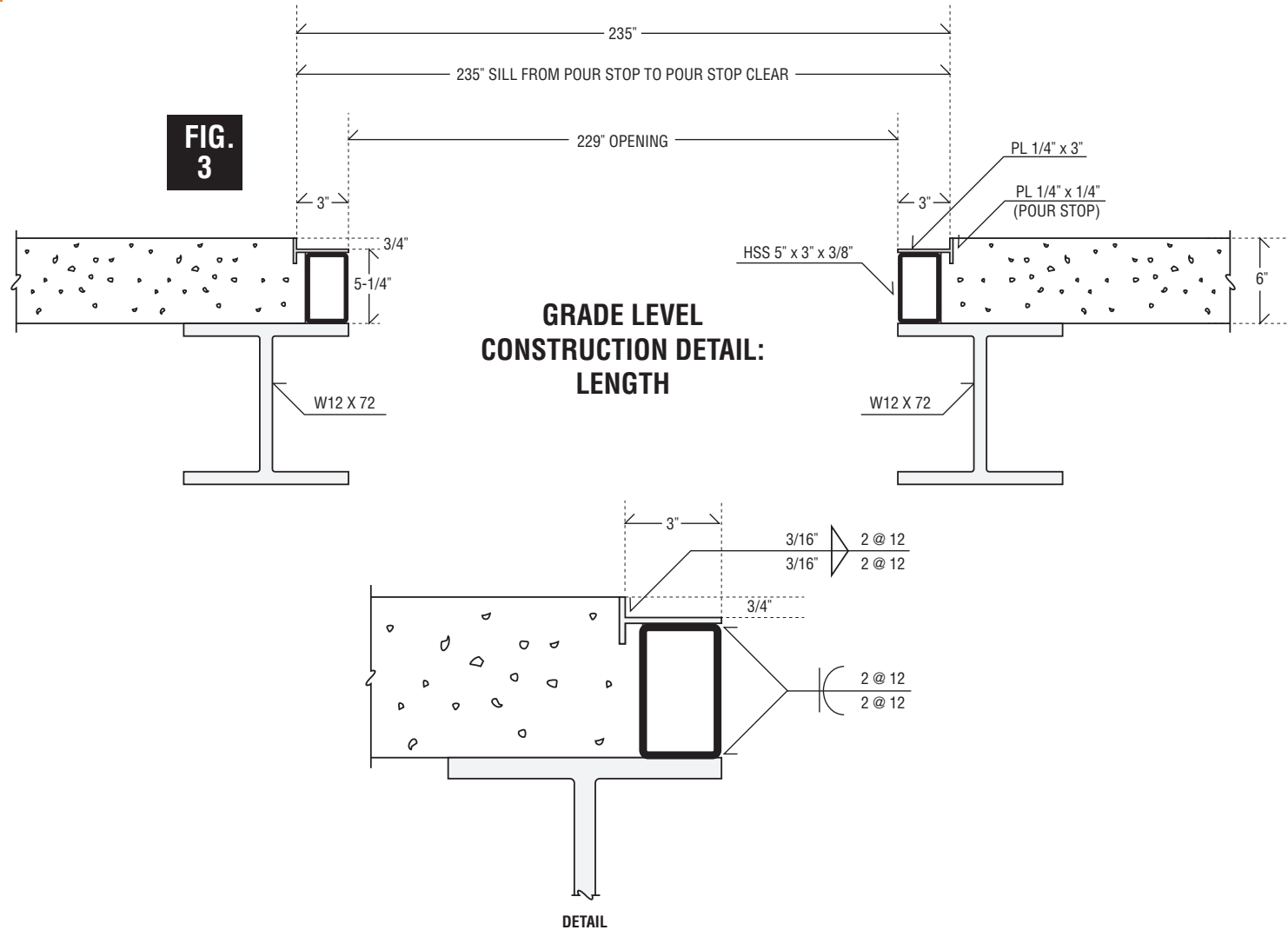

FIG.
1

EDGE DETAIL SAMPLE USING
TUBE STEEL OVER STRUCTURAL BEAM



EDGE DETAIL SAMPLE USING
TUBE STEEL OVER STRUCTURAL BEAM



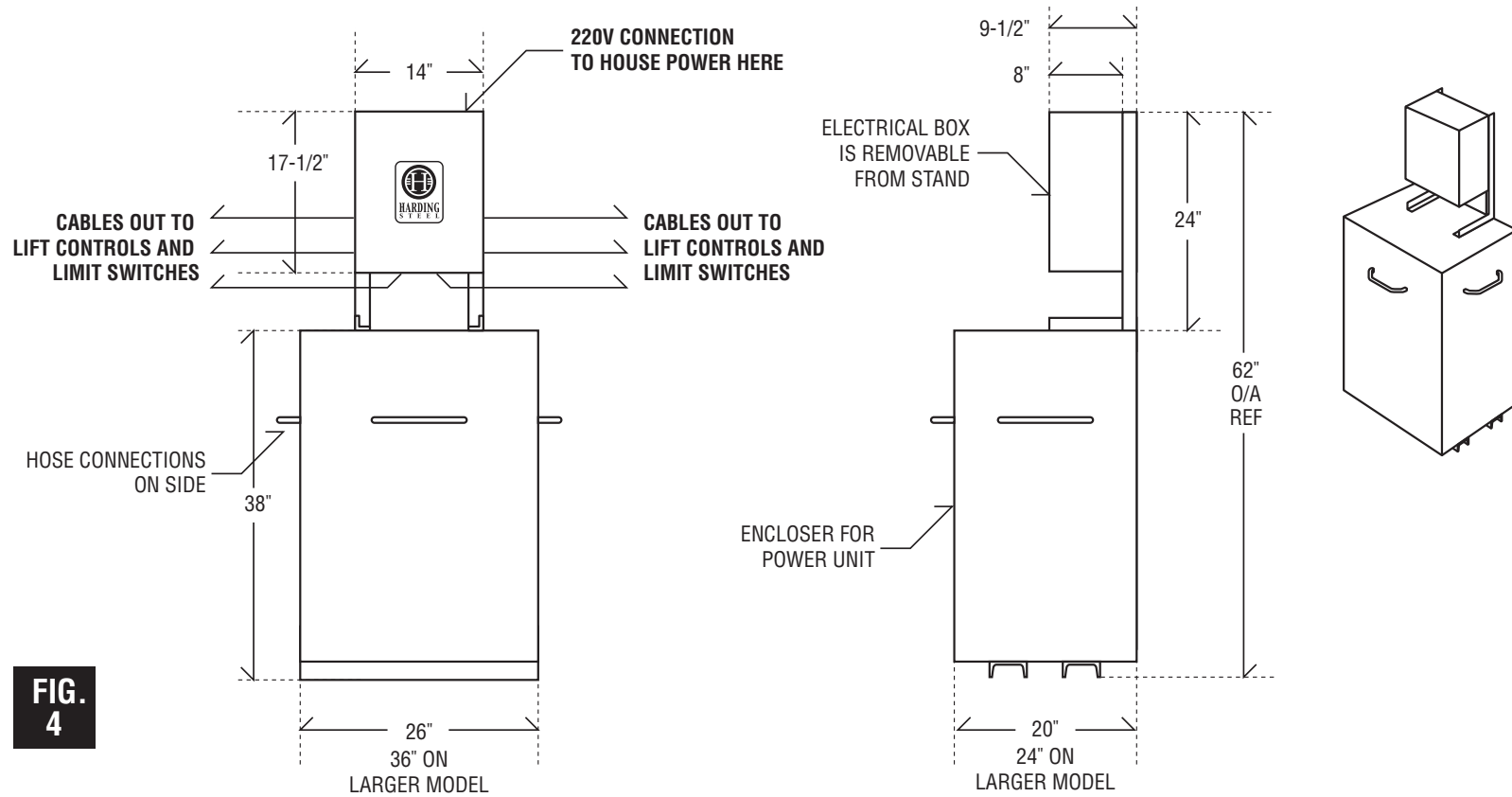

CARPARX™ ST-3

FEATURES

- 100% premium steel construction
- Commercial grade design and materials
- Single scissors architecture for unsurpassed stability
- Four high capacity hydraulic cylinders
- Self-standing, self-supporting unit
- Suitable for indoor or outdoor installation
- 220V high flow hydraulic power pack and controls
- Oversized all diamond-plate steel platforms (3)
- Accommodates full size SUVs on top level only (subject to available clearances)
- Quality enamel paint finish throughout
- Optional galvanized steel vehicle platforms
- Seismic Zone 4 certified

DIMENSIONS

Upper platform: 234"L x 102"W (fits XL SUV/Trucks)

- Lower platforms: 226"L x 94"W
- Interplatform clearance: 65" conventional sedans
- Minimum pit depth (finished floor to finished floor): 158"
- Ceiling clearance requirements (to raise unit with upper car in place)
- 137" plus height of upper car:

Sedan: 197"

SUV: 209"

- Pit opening (finished): 228"L x 98"W
- Weight Capacities:
 - Lower car: 5,000 lbs.
 - Middle car: 5,000 lbs.
 - Upper car: 6,000 lbs
- Approximate machine weight: 15,000 lbs.

WARRANTY

One year electrical, two year mechanical, five year structural

SAFETY

- Platforms are free of all trip hazards, pit gaps, or protruding columns
- Key-operated control switch for security and safety
- Hydraulic velocity fuses on all cylinders
- Automatic shut-off if operator releases the key-switch
- Wiring block for integrating safety interlock devices
- Front railing protects garage walls and bumpers
- Optional ceiling sensor kit available

NOTE: ST-3 units are all built-to-order and all dimensions are subject to final shop drawings and project specifics.