

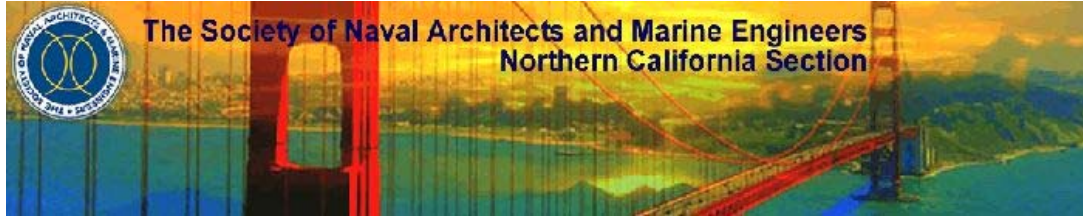

The Society of Naval Architects and Marine Engineers
Northern California Section



NSMV Training Ship Design for the US Maritime Administration

Eugene Van Rynbach, Herbert Engineering Corp.

February 21, 2018



NSMV Mission

- ▶ National Security Multi-Mission Vessel (NSMV)
- ▶ Design sponsored by the US Maritime Administration (MARAD)
 - MARAD is responsible for providing training ships to the State Maritime Academies (SMA) – in the past these have been converted vessels, some of which are now over 40 years old
- ▶ New Training Vessel for up to five SMAs to replace aged vessels
 - Primary Role is to act as standard design training vessel for the State Maritime Academies
 - Utilize modern propulsion system
 - Incorporate modern teaching and training facilities
- ▶ Alternate Missions
 - Act as support vessel for Humanitarian Assistance and Disaster Response (HA/DR) missions – such as after major hurricanes and earthquakes
 - Have capability to support that role in wide variety of ports
 - Provide accommodation for support personnel
 - Provide secure communications and command spaces

Overview of Phase 3 Design Tasks

- ▶ Phase 3 is complete basic design sufficiently to allow shipyard bidding (similar to contract design) – Over 60 deliverables
- ▶ Build off Concept Design completed in 2015 and incorporate MARAD and SMA Comments from the concept design
- ▶ Prepare detailed General Arrangement, Machinery Arrangements & Galley/Mess Arrangement
- ▶ Prepare full ship Finite Element Analysis (FEA) and prepare main structural drawings
- ▶ Size Main and Auxiliary machinery and prepare Machinery List & Calculation Booklet
- ▶ Prepare Key System Piping & HVAC Diagrams
- ▶ Prepare Electric Load Analysis, Key One Line Diagram and Technical Specs for Main Electrical Components
- ▶ Prepare Detailed Weight Estimate, Intact and Damaged Stability Analyses
- ▶ Prepare Bidding Specification
- ▶ Prepare Detailed Cost Estimate for Construction of 1 to 5 ships
- ▶ Submit all key drawings to ABS for approval in Principal

Phase 3 Design Team

- ▶ Herbert Engineering – Project Lead
 - Eugene Van Rynbach – Project Manager
 - Karl Briers – Marine Engineering
 - Luca Letizia, Phd (HEC Europe) – Stability Analysis
 - Courtney Crouse - Structures
- ▶ SPAR Associates – Cost Estimating
 - Laurent Deschamps – Lead Estimator
- ▶ Consultants
 - Carl Setterstrom – Naval Architecture, Regulations
 - Jamestown Metal – Accommodation & Galley Arrangement
 - SSPA (Swedish Model Basin) – Hull & Prop. Design, Model Testing
 - VT Group – IT Infrastructure
 - Fabio Cigoj – Electrical Systems
 - Rosenblatt & Associates – Accom. Piping Systems, Mach Arrg'ts

Design Challenges

- ▶ Stay within the size and mooring limitations of each of the Academies – about 550 ft Length x 90 ft Beam
- ▶ Incorporate, as practical, the teaching and training requirements of the Academies based on a consolidated wish list was prepared by the SMA's, plus input received during visits to the academies
- ▶ Determine the appropriate regulatory regime for a training ship as it is neither a passenger ship nor a cargo ship – after discussion with USCG decided upon using the IMO Code for Special Purpose Ships and the appropriate 46 CFR Chapters
- ▶ Incorporate best practices and recommendations from the existing training ships – visited 3 training ships and talked to the operating and training staff
- ▶ Incorporate commercial practice and equipment as feasible to keep cost reasonable
- ▶ Provide capability for alternate HA/DR missions without compromising training ship capability
- ▶ Meet new rigorous SOLAS safety and stability requirements for 700+ person vessel

Energy Efficiency & Environmental Enhancements

- ▶ Hull Optimized for Efficiency at multiple drafts – 10% reduction in propulsion power compared to typical vessel of this size
- ▶ HVAC Improved Efficiency
 - Hot water from the main engines provided heat to accommodation spaces – 950 kW savings (30% of ship service load)
 - Air Handlers with Recovery Wheels to recycle heat/cold in return air to incoming air for decks 02 to 05 – 8% HVAC load reduction
 - Fan coils used for space cooling, separate spaces for electric gear that needs to be cooled, instantaneous hot water heaters in isolated lavatories
- ▶ Specified use of LED lights where feasible
- ▶ Specified Clean Burning Low Sulfur Distillate Diesel Fuel (Marine Gas Oil)
- ▶ Fully Compliant with Environmental Regulations including Ballast Water Treatment, Fuel Tank Isolation from Side Shell, EPA Vessel Discharge Permit, etc.
- ▶ ABS Enviro and Green Passport Notations Applied
 - Meet highest environmental standards required by international regulations
 - Toxic substances use minimized throughout the life of the vessel
 - Reduce discharges to air and water of any pollutants

NSMV Video & Rendering



Multi--Mission Stern Area on NSMV

3- D Renderings



Profile View with Containers on Aft Area

NSMV – Key Capabilities

- ▶ Principal Dimensions
 - Length 159.85 m (524'-5")
 - Beam 27.0 m (88'-7")
 - Depth 16.8 m (55'-1.5")
 - Design Draft 6.5 m (21'-4")
- ▶ Propulsion, Speed & Consumption
 - Diesel Electric – 4 main engines divided between 2 engine rooms
 - Installed Power – 15,700 kW
 - Full Speed – 18 knots with 15% sea margin – 4 engines
 - Cruising Speed -12 knots with 2 main engines in one engine room
 - Uni-fuel for simplicity and operation in the US ECA – MGO only

NSMV – Key Capabilities

- ▶ Range
 - 11,000+ miles at 18 knots
- ▶ Maneuvering – Docking without tugs
 - Bow Thruster – 1,480 kW Combi-type – tunnel thruster in normal maneuvering and drop down azimuthing type for “Take Home” power
 - Stern Thruster – 890 kW Tunnel type
 - Flap type rudder for improved low speed maneuverability
- ▶ Accommodation
 - Training Ship Mode – 600 cadets, 100 officer, faculty, staff & crew
 - All non-cadets in single cabins with private lavatory unit
 - Surge capacity for HA/DR missions
 - Food Storage for 60 days
- ▶ Teaching & Training Facilities (as shown in the video)

NSMV – Key Capabilities

- ▶ Emergency Response (HA/DR) Capabilities
 - RoRo space with Side Ramp
 - Cargo Crane
 - Container and Cargo Stowage on Main Deck
 - Capability for Modules (such as medical) on Main Deck
 - Helicopter Landing Capability
 - Command & Communications Suite
 - Enhanced Medical & Treatment Spaces
 - Berthing spaces available for use by HA/DR personnel

Regulations Overview

- ▶ USCG Subchapter R – Public Nautical School Ship
 - Structure according to ABS Rules for Passenger Vessels
 - Stability – one compartment standard (less severe than SOLAS)
 - Lifesaving – same as passenger vessels
 - Structural fire protection – same as passenger vessels (by policy)
- ▶ SPS – Statement of Voluntary Compliance with Code of Safety for Special Purpose Ship (similar to SOLAS)
 - Stability – SOLAS passenger vessel damage criteria (two compartment probabilistic)
 - Structural fire protection – SOLAS passenger vessel (similar to USCG requirements)
 - Safe Return to Port - Requires redundancy of critical functions in event of flooding or fire in any one compartment –
 - Lifesaving – SOLAS passenger vessel requirements (similar to USCG requirements)

Model Testing



- ▶ SSPA Optimized Hull Lines using CFD Analysis
- ▶ Bow Reshaped for reduced resistance



NSMV Model at SSPA work basin
Model testing carriage in background

Model Testing



- ▶ Model Test at Full load (7.5 m draft) at 18 knots
- ▶ Model Test Results based on CFD optimized hull indicated 10% less power required than initial hull design

NSMV – Structural Design

- ▶ Full Ship Finite Element Analysis
 - In compliance with ABS Rules for Passenger Ships
 - Modeled the entire vessel
 - Detailed Models prepared for areas of high stress
 - Transition from Deckhouse to Open Aft Deck just aft of Midship was found to be key area of high stress and required design changes:
 - Relocation of the side ramp to aft
 - Installation of large transition brackets
 - Separation of Multipurpose Space from main deckhouse
- ▶ Prepared Key Structural Drawings
 - Midship Section
 - Hull Scantling Plan
 - Deckhouse Scantling Plan
 - Typical Transverse Bulkheads
 - Shell Expansion

Finite Element Analysis (FEA) Results

Global FEA Model

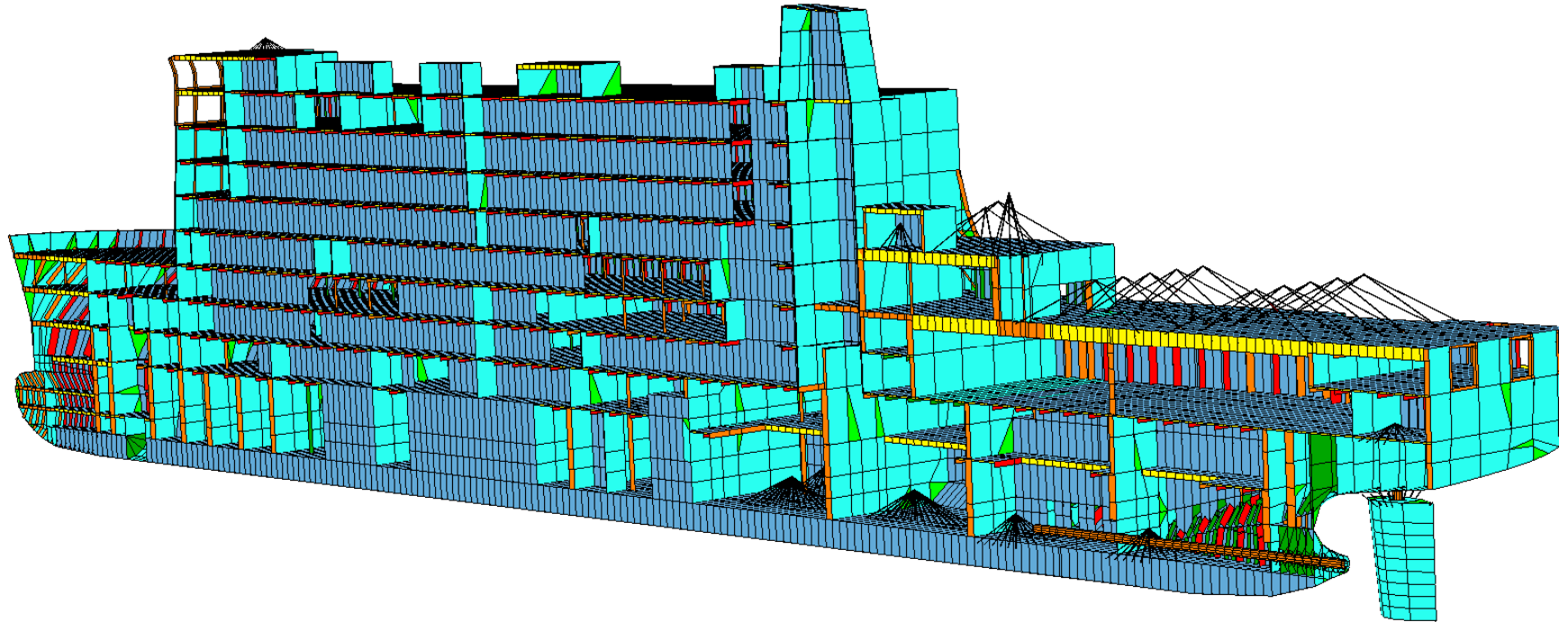

- FEA checks overall structural adequacy of the hull per detailed ABS requirements for passenger ships, so no surprises for contracted shipyard.
- Hull analyzed for fatigue to ensure adequacy for life of 20+ years of full time operation – actual operation is much more intermittent so life extended

Finite Element Analysis Results

Hull Deflection from Max Hog Wave

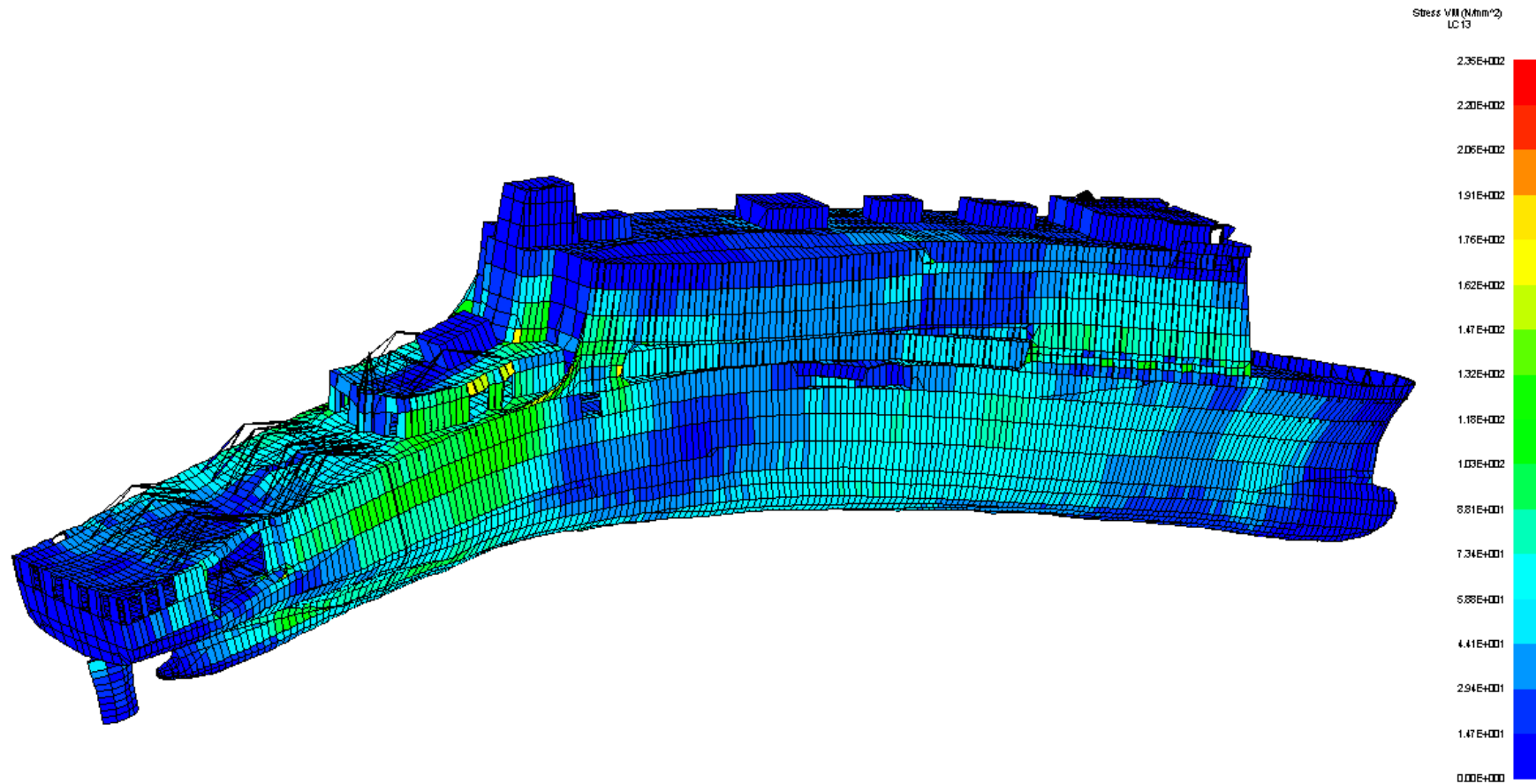

Finite Element Analysis Results

Fine Mesh Analysis of Aft Ramp Opening

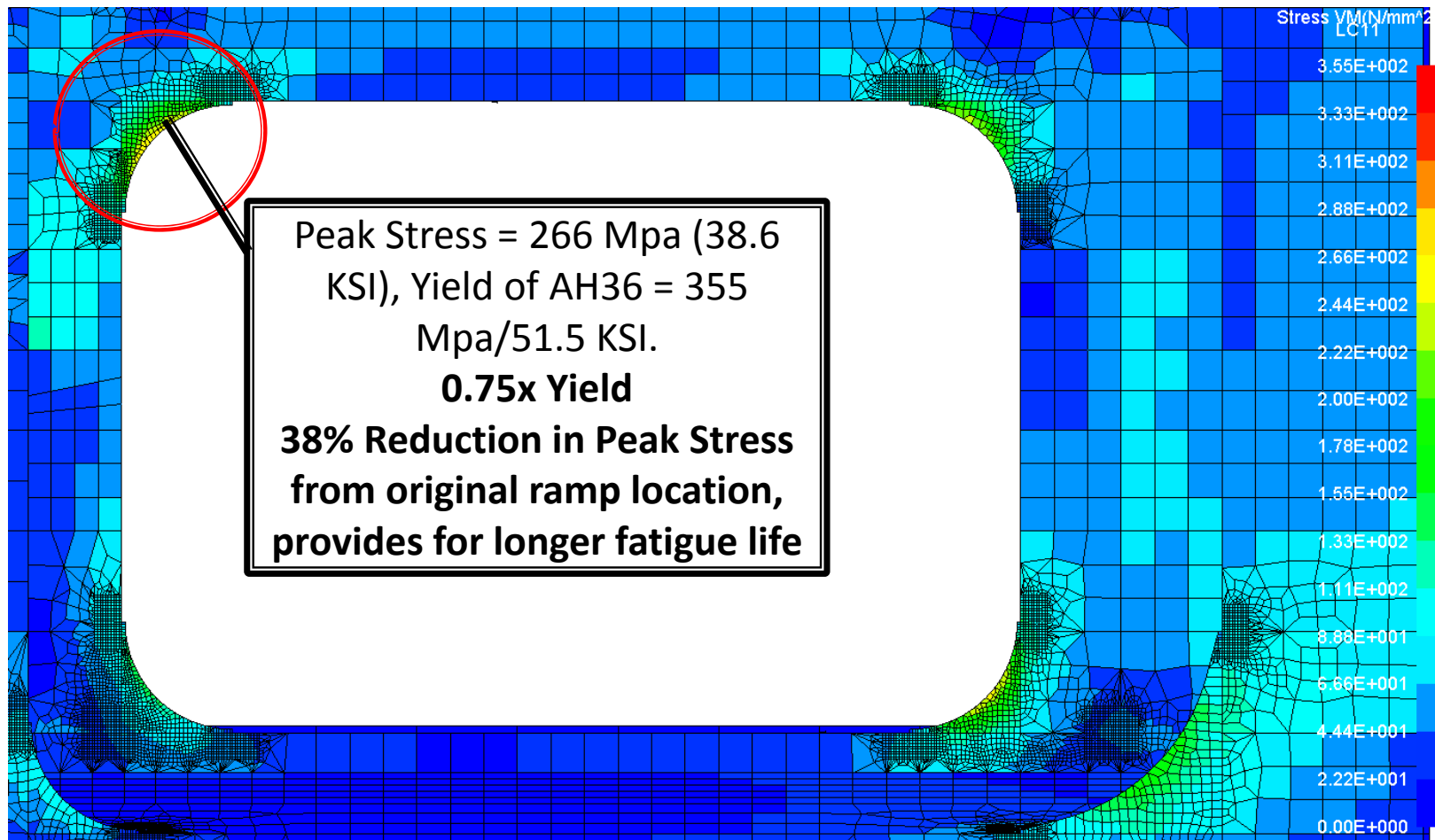

Detailed Galley & Mess Arrangement

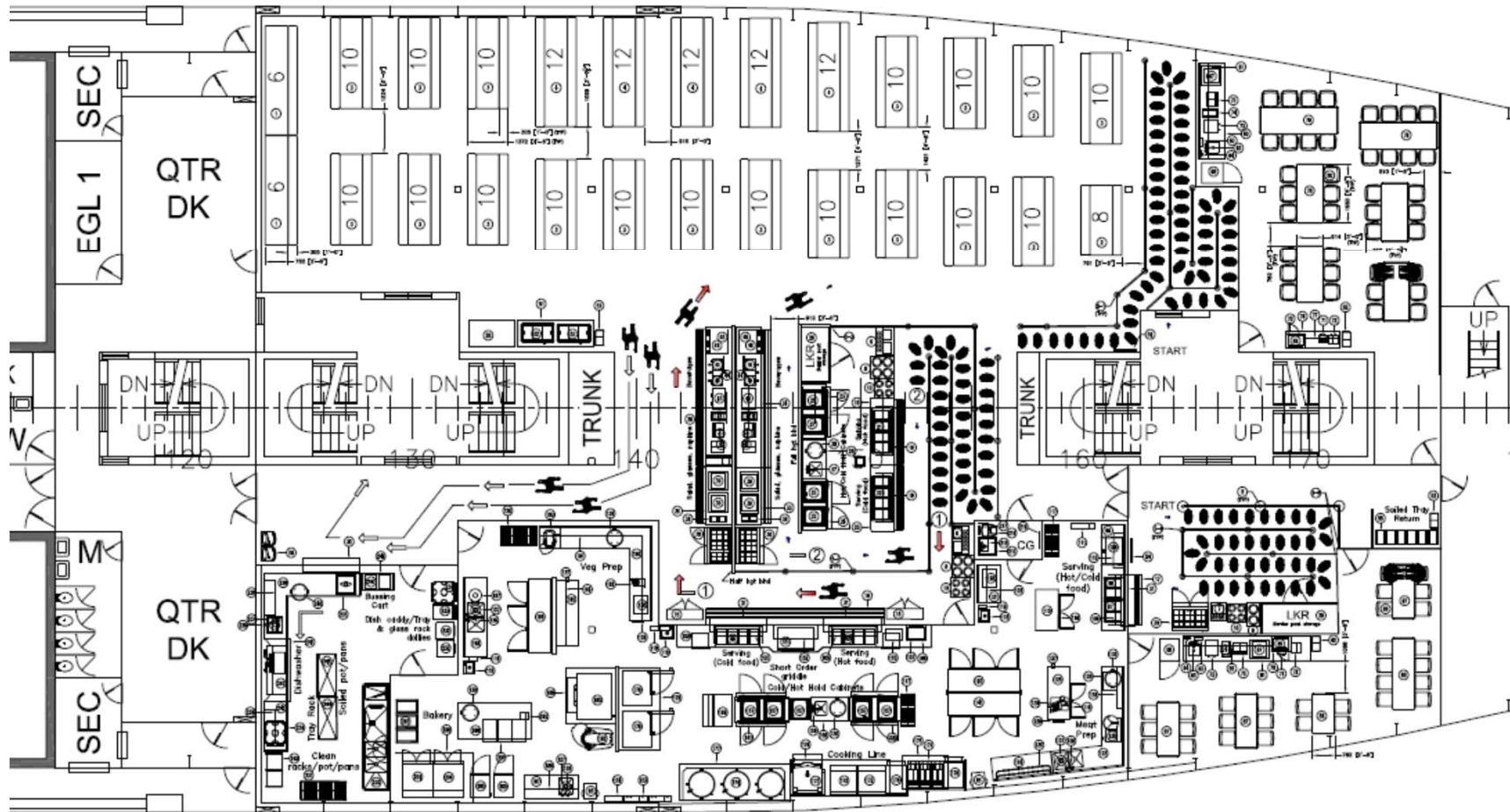

Typical Piping Diagram

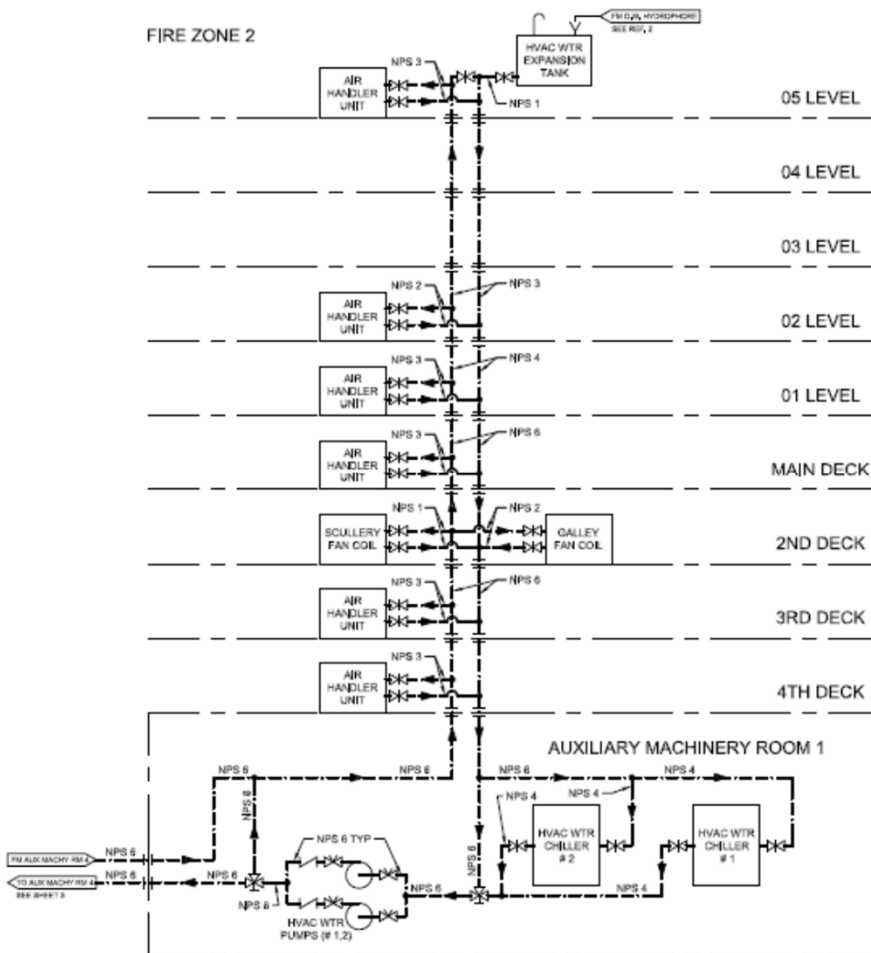

HVAC Water Heating Diagram-

Utilization of waste heat from engines for accommodation heating

Fiber Optic Network in all Accommodation Spaces

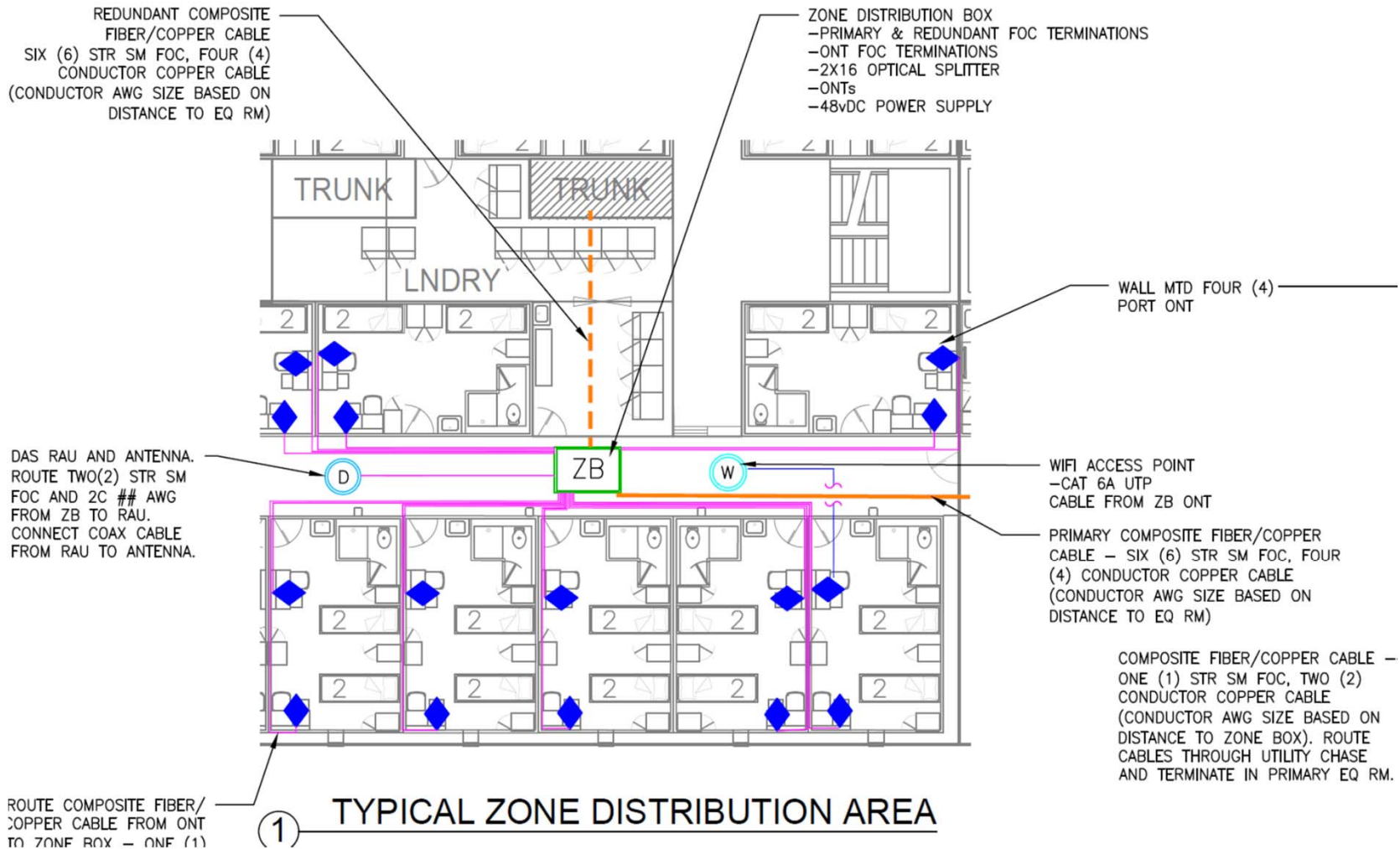

Stability

▶ Stability Criteria

- IMO 2008 Intact Stability Code – General and Weather
- Damage Stability – 3 Criteria Applied
 - SOLAS II-1, Part B (2009)
 - MARAD Design Letter 3 (one compartment)
 - 46CFR Part 170 & 171 (Passenger Vessels – one compartment standard applies to public nautical school ship)

▶ SOLAS 2009 Damage Stability Analysis was Governing

- Probabilistic analysis with damages in up to 3 zones
- HECSALV Software used to model the vessel and run the damage analysis using specially developed routine for passenger vessel analysis
- Required Index of 0.71 - Attained Index of 0.796
- Regulation 8.2 requires Index of 0.9 for shallow damages - most difficult to comply with
- To meet damage stability required almost all compartments extending outboard of B/5 and to bottom to be symmetrical

Sample Load Case – Training Ship Mode

No Cargo Departure
Weight Summary

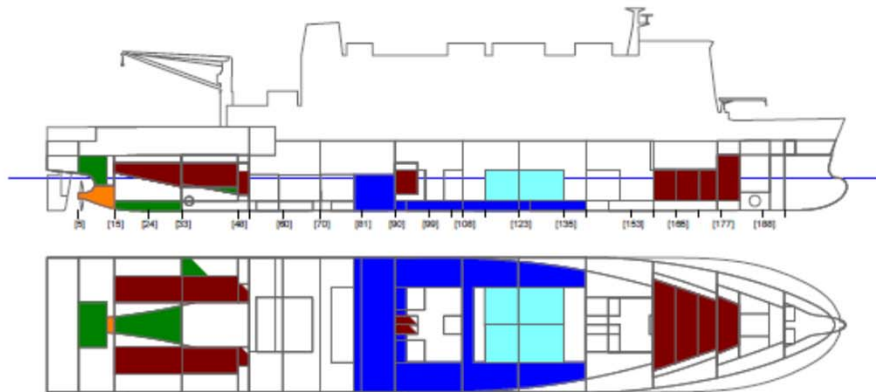

Group	Weight MT	VCG m-BL	LCG m-[FR]	TCG m-CL	FSt m-MT	Group Min FS m-MT
Lightship	10,750.00	13.010	0.282A[102]	0.090	0.0	
SW Ballast	380.60	6.467	0.266F[20]	-2.341	41.8	
FW Ballast	1,236.15	1.620	0.294F[103]	0.000	0.0	
MGO	1,769.85	6.493	0.318F[109]	0.000	1,365.1	1,327.2
Fresh Water	1,379.31	5.106	0.375A[125]	-0.026	555.8	555.8
Misc	34.35	2.844	0.109F[12]	0.000	91.4	91.4
Voids	0.00	--	--	--	0.0	
Containers	0.00	--	--	--	0.0	
Constant	732.50	12.698	0.016F[98]	0.000	0.0	
Cargo	0.00	--	--	--	0.0	
Displacement	16,282.76	10.579	0.220F[102]	0.003	2,054.2	
Deadweight	5,532.76					
Avail Deadweight	2,968.36	--Summer LL--				

Loading

Displacement 16,282.76 MT Specific Gravity 1.0250

Deadweight 5,532.76 MT

Avail Deadweight 2,968.36 MT

--Summer LL--

Stability

KMt 13.117 m LCF Draft 6.336 m

VCG (Upright) 10.579 m LCF 0.095A[98] m-[FR]

GMt (Solid) 2.538 m LCB 0.341A[103] m-[FR]

FS Correction 0.126 m LCG 0.220F[102] m-[FR]

GMt (Corrected) 2.412 m TP1cm 31.5 MT/cm

GMt Required 1.712 m MT1cm 226 m-MT/cm

GMt Margin 0.699 m Trim at Perps 0.136 m

--SOLAS 2009 & IS Code-- Heel Angle 0.06 deg

Propeller Immersion 107.414 %

Drafts - Perps

AP 6.400 m

MS 6.332 m

FP 6.264 m

Strength

Shear (Min) -1,228.03 MT 118.650 m-[FR]

Shear (Max) 1,386.07 MT 35.400 m-[FR]

Moment (Max Hog) 51,859.1H m-MT 57.410 m-[FR]

Acknowledgements

- ▶ Many people contributed to supporting and encouraging the design effort and provided useful guidance. Some of the key people are:
- ▶ MARAD NSMV Team
 - Maritime Administrator (has changed during the project)
 - Kevin Tokarski – Assoc. Administrator for Strategic Sealift
 - Chris Moore & Paul Gilmour – Project Managers
 - Technical Advisory Team – Dave Heller, Chao Lin, Tony Margan
- ▶ US Coast Guard
 - John Hannon – Director, US Flag & Military Sealift Programs (CG-CVC-1)
 - Jaideep Sirkar – Chief, Naval Architecture Division (CG-ENG-2)
 - Charles Rawson – Naval Architect (CG-ENG-2)
- ▶ State Maritime Academies we visited
 - California Maritime Academy
 - Massachusetts Maritime Academy
 - NY Maritime Academy

NSMV – Going Forward

