

INDIAN WELLS VALLEY GROUNDWATER AUTHORITY

Ridgecrest City Hall 100 W California Ave., Ridgecrest, CA 93555 760-499-5002

BOARD OF DIRECTORS SPECIAL MEETING AGENDA

Friday, March 29, 2024

Closed Session – 10:15 a.m.

Open Session – No earlier than 11:00 a.m.

Pursuant to California Government Code 54953(b)(1) two additional call-in locations have been established for Board Members who will attend this meeting via teleconference at 14955 Dale Evans Parkway Apple Valley, CA. 92307 and at 1360 N Main St Bishop, CA. 93514.

NOTICE: *In accordance with the evolving public health declarations, we will continue to provide live stream video for those wishing to participate virtually. Please see the Public Comment Notice below for detailed instructions on submitting public comment as well as websites for livestream broadcasting.*

In compliance with the Americans with Disabilities Act, if you are a disabled person and you need a disability-related modification or accommodation to participate in this meeting, please contact April Keigwin at (805) 764-5452. Requests must be made as early as possible and at least one full business day before the start of the meeting. Documents and material relating to an open session agenda items that are provided to the IWVGA Board of Directors prior to a regular meeting will be available for public inspection and copying at Ridgecrest City Hall, 100 W California Ave, Ridgecrest, CA 93555, or online at <https://iwvga.org/>.

Statements from the Public

The public will be allowed to address the Board during Public Comments about subjects within the jurisdiction of the IWVGA Board and that are NOT on the agenda. No action may be taken on off-agenda items unless authorized by law. Questions posed to the Board may be answered after the meeting or at future meeting. Dialog or extended discussion between the public and the Board or staff will be limited in accordance with the Brown Act. All Public Comment portions of the meeting shall be limited to three (3) minutes per speaker. Each person is limited to one comment during Public Comments.

1. CALL TO ORDER

2. ADOPTION OF AGENDA

3. PUBLIC COMMENT ON CLOSED SESSION

4. CLOSED SESSION

- CONFERENCE WITH REAL PROPERTY NEGOTIATIONS –
(Government Code Section 54956.8) - Property: Purchase of Water Rights; Agency Negotiator: Jeff Simonetti; Negotiating Parties: Palmdale Municipal Water District; Under Negotiation: Price and terms of payment.

- CONFERENCE WITH LEGAL COUNSEL – EXISTING LITIGATION
(Government Code Section 54956.9(d)(1)): IWVGA v. Inyokern CSD – Kern County Superior Court BCV-22-100281

- CONFERENCE WITH LEGAL COUNSEL – EXISTING LITIGATION
(Government Code Section 54956.9(d)(1) - Name of case: Searles Valley Minerals Inc v. Indian Wells Valley Groundwater Authority, et. al. - Orange County Superior Court 30-2022-01239487-CU-MC-CJC

- CONFERENCE WITH LEGAL COUNSEL- EXISTING LITIGATION
(Government Code Section 54956.9(d)(1) - Name of case: Mojave Pistachios, LLC, a California limited liability company, et.al. v. Indian Wells Valley Groundwater Authority, a California Joint Powers Authority, et. al. - Orange County Superior Court 30-2022-0139479-CU-MC-CJC

5. OPEN SESSION – No earlier than 11:00 a.m.

- a. Report on Closed Session
- b. Pledge of Allegiance
- c. Roll Call

6. PUBLIC COMMENT

This time is reserved for the public to address the Board about matters NOT on the agenda. No action will be taken on non-agenda items unless authorized by law. Comments are limited to three minutes per person.

7. BOARD MEMBER COMMENTS

This time is reserved for comments by Board members and/or staff and to identify matters for future Board business.

8. CONSENT AGENDA

- a. Approve Minutes of Board Meeting February 14, 2024
- b. Insurance Renewal
- c. Approve Expenditures
 - *To view itemized invoices please visit <https://iwvga.org/iwvga-meetings>
 - i. \$128,404.96 – Stetson Engineers
 - ii. \$22,085.56 – Regional Government Services – (Replenishment / Extraction)
 - iii. \$19,787.50 – Capitol Core Group – (Replenishment)
 - iv. \$110,689.29 – Provost & Pritchard – (SGMA IP Grant)
 - v. \$150.00 – TranSystems – (SGMA IP Grant)
 - vi. \$1,573.20 – WellIntell – (Extraction)
 - vii. \$100.00 – California Association of Mutual Water Companies (Extraction)

9. BOARD TO RECEIVE AND FILE WATER YEAR 2023 ANNUAL REPORT

10. SHALLOW WELL MITIGATION FUNDING REQUEST

- a. Halpin
- b. Byerly

11. APPROVAL OF CHANGE IN SCOPE OF WORK AND BUDGET FOR CONTRACT WITH PROVOST AND PRITCHARD CONSULTING GROUP FOR CEQA/NEPA DOCUMENTS AND PERMIT DOCUMENTATION SERVICES FOR THE IMPORTED WATER PIPELINE

12. WATER RESOURCES MANAGER REPORT

- a. Grant Funding
- b. GSP Implementation Projects/Management Action Updates
 - i. Imported Water Project
 - ii. Shallow Well Mitigation Program
 - iii. GSP Update
- c. Miscellaneous Items
 - i. Data Collection and Monitoring
 - ii. IWVGA Basin Model Configuration Management Plan
 - iii. Rose Valley Subflow Update⁷

13. GENERAL MANAGER'S REPORT

- a. Monthly Financial Report
- b. C&E Plan Update
- c. Report on IWVGA's Water Marketer (Capitol Core Group)

14. DATE OF NEXT MEETING – APRIL 10, 2024

15. ADJOURN

PUBLIC COMMENT NOTICE

IWVGA meetings will be open to the public for physical attendance; However, for those who wish to continue using virtual alternatives please follow the directions below for access to live stream video as well as ways to submit public comment.

- **Watch meetings on-line:**
All of our meetings are streamed live at <https://ridgecrest-ca.gov/369/Watch> (4 second streaming delay) or on YouTube at <https://www.youtube.com/cityofridgecrest/live> (22 second streaming delay) and are also available for playback after the meeting.
- **Call in for public comments:**
If you wish to make verbal comment, *please call (760) 499-5010*. This phone line will allow only one caller at a time, so if the line is busy, please continue to dial. We will be allowing a 20-30 second pause between callers to give time for media delays and callers to dial in. Due to media delays, please mute your streaming device while making public comment. If you wish to comment on multiple items, you will need to call in as each item is presented.
**Please Note – This process will be a learning curve for all, please be patient.*
- **Submit written comments:**
We encourage submittal of written comments supporting, opposing, or otherwise commenting on an agenda item, for distribution to the Board prior to the meeting. Send emails to akeigwin@rgs.ca.gov written correspondence may be sent to April Keigwin, Clerk of the Board, 100 W. California Ave., Ridgecrest, CA 93555. Please specify to which agenda item your comment relates.

- **Large Groups:**

If you are part of a large group that would like to comment on an agenda item, please consider commenting in writing. This will be as impactful to the Board as having a large group in attendance.

The page intentionally blank

INDIAN WELLS VALLEY GROUNDWATER AUTHORITY

City of Ridgecrest, Indian Wells Valley Water District, Inyo County, Kern County, San Bernardino County

BOARD OF DIRECTORS MEETING MINUTES Wednesday, February 14, 2024

IWVGA Members Present:

Chairman Phillip Peters, Kern County	Carol Thomas-Keefer, IWVGA General Manager
Scott Hayman, City of Ridgecrest	Phillip Hall, Legal Counsel
Chuck Griffin, IWVWD	Steve Johnson, Stetson Engineers
John Vallejo, Inyo County	John Kersey, US Navy, DoD Liaison
Emma Lynch, Bureau of Land Management	April Keigwin, Clerk of the Board

Attending via teleconference is John Vallejo, Carol Thomas-Keefer, and Steve Johnson.

Meeting recording, public comment letters submitted, and all board meeting related documents are made available at:
<https://iwvga.org/iwvga-meetings/>

1. CALL TO ORDER:

Chairman Peters calls the meeting to order at 10:05 a.m.

2. ADOPTION OF AGENDA:

The Board hears public comment from Renee Westa-Lusk.

Motion made by Scott Hayman and seconded by Chuck Griffin to approve adoption of the agenda.
Motion carries by the following roll call vote:

Chairman Peters	Aye
Vice Chair Hayman	Aye
Director Itnyre	Absent
Director Griffin	Aye
Director Vallejo	Aye

3. PUBLIC COMMENT ON CLOSED SESSION:

None.

Chairman Peters calls the meeting into Closed Session at 10:05 a.m.

4. CLOSED SESSION:

- CONFERENCE WITH REAL PROPERTY NEGOTIATIONS –
(Government Code Section 54956.8) - Property: Purchase of Water Rights; Agency Negotiator: Jeff Simonetti; Negotiating Parties: Palmdale Municipal Water District; Under Negotiation: Price and terms of payment.
- CONFERENCE WITH LEGAL COUNSEL – EXISTING LITIGATION
(Government Code Section 54956.9(c)): IWVGA v. Inyokern CSD

- CONFERENCE WITH LEGAL COUNSEL – EXISTING LITIGATION
(Government Code Section 54956.9(d)(1) - Name of case: Searles Valley Minerals Inc v. Indian Wells Valley Groundwater Authority, et. al. - Orange County Superior Court 30-2022-01239487-CU-MC-CJC
- CONFERENCE WITH LEGAL COUNSEL- EXISTING LITIGATION
(Government Code Section 54956.9(d)(1) - Name of case: Mojave Pistachios, LLC, a California limited liability company, et.al. v. Indian Wells Valley Groundwater Authority, a California Joint Powers Authority, et. al. - Orange County Superior Court 30-2022-0139479-CU-MC-CJC

Closed Session adjourns at 11:29 a.m.

5. OPEN SESSION – No earlier than 11:00 a.m.

Meeting reconvenes into Open Session at 11:37 a.m.

- a. Report on Closed Session – Counsel Hall reports no reportable action was taken that would require disclosure under The Brown Act. Counsel Hall reports the Court of Appeals for the Fourth Appellate District denied the petition filed by Mojave Pistachios which was seeking to overturn the replenishment fee as well as seeking \$255,000,000.00 in damages. Mojave Pistachios was found to not have a takings claim and was unable to challenge the fee due to the “Pay First Litigate Later” rule.
- b. Pledge of Allegiance is led by Chairman Peters
- c. Roll Call

Chairman Peters	Present
Vice Chair Hayman	Present
Director Griffin	Present
Director Itnyre	Absent
Director Vallejo	Present

6. PUBLIC COMMENT:

The Board hears public comment from Renee Westa-Lusk

7. BOARD MEMBER COMMENTS:

8. CONSENT AGENDA:

- a. Approve Minutes of Board Meeting January 10, 2024
- b. Approve Expenditures

**To view itemized invoices please visit <https://iwvga.org/iwvga-meetings>*

- i. \$122,793.47 – Stetson Engineers
- ii. \$26,572.50 – Regional Government Services – (Replenishment / Extraction)
- iii. \$16,387.50 – Capitol Core Group – (Replenishment)
- iv. \$284,502.09 – Provost & Pritchard – (SGMA IP Grant)
- v. \$745.00 – TranSystems – (SGMA IP Grant)

Motion made by Chuck Griffin and seconded by Scott Hayman to approve Minutes of Board Meeting January 10 with edits to sections 1 and 3 changing Chairman Hayman to Chairman Peters, and the following expenditures in the amount of, \$122,793.47 to Stetson Engineers, \$26,572.50 to Regional Government Services, \$16,387.50 to Capitol Core Group, \$284,502.09 to Provost & Pritchard, and \$745.00 to TranSystems.

Motion carries by the following roll call vote:

Chairman Peters	Aye
Vice Chair Hayman	Aye
Director Itnyre	Absent
Director Griffin	Aye
Director Vallejo	Aye

9. RESOLUTION 02-24 AUTHORIZING A REIMBURSEMENT AGREEMENT WITH ANTELOPE VALLEY EAST KERN:

Jeff Helsley provides staff report and presentation.

Motion made by Scott Hayman and seconded by John Vallejo to approve Resolution 02-24 authorizing reimbursement agreement with Antelope Valley East Kern.

Motion carries by the following roll call vote:

Chairman Peters	Aye
Vice Chair Hayman	Aye
Director Itnyre	Absent
Director Griffin	Nay
Director Vallejo	Aye

10. WATER RESOURCES MANAGER REPORT:

- a. Grant Funding
- b. GSP Implementation Projects/Management Action Updates
 - i. Imported Water Project
 - ii. Shallow Well Mitigation Program
 - iii. GSP Update
 - iv. 2023 Annual Report
- c. Miscellaneous Items
 - i. Data Collection and Monitoring
 - ii. IWVGA Basin Model Configuration Management Plan
 - iii. Rose Valley Subflow Update

The Board hears public comment from Judie Decker and West Katzenstein.

11. GENERAL MANAGER'S REPORT:

Carol Thomas-Keefer provides Monthly Financial Report and C&E update. Michael McKinney of Capitol Core Group presents Technical Memorandum, Legislative Agenda and WRDA funding request.

The Board hears public comment from Judie Decker and Renne Westa-Lusk.

12. DATE OF NEXT MEETING – MARCH 13, 2024

13. ADJOURN:

Chairman Hayman adjourns the meeting at 12:21 p.m. on February 14, 2024.

Respectfully submitted,

April Keigwin
Clerk of the Board
Indian Wells Valley Groundwater Authority

The page intentionally blank



**CALIFORNIA ASSOCIATION OF MUTUAL WATER COMPANIES
JOINT POWERS RISK AND INSURANCE MANAGEMENT AUTHORITY (JPRIMA)
PACKAGE/AUTO/EXCESS**

COVERAGE PROPOSAL FOR:

Indian Wells Valley Groundwater Authority

COVERAGE PERIOD:

4/1/2024 - 4/1/2025

PRESENTED BY:

Walter Mortensen Insurance

PROGRAM MANAGER

Allied Public Risk, LLC
CA DBA: Allied Community Insurance Services, LLC
CA License No. 0L01269
National Producer No. 17536322
www.alliedpublicrisk.com
(858) 866-8966

PREMIUM SUMMARY

NOTE: This proposal is prepared from information supplied to us on the application submitted by you or your insurance broker. It may or may not contain all terms requested on the application. Please review carefully and let us know if any additional information is required. In addition, this proposal may contain unintentional errors or omissions. We encourage you to bring them to our attention for review. This proposal does not amend, or otherwise affect or alter, the provisions of coverage provided. This proposal does not guarantee coverage for specific claims or losses under the policy. The availability of coverage depends on the JPRIMA Memorandum of Coverage (MOC) and is subject to its terms and conditions, the facts surrounding any potential claims, and relevant legal requirements. A specimen MOC is available for your review, as is the JPRIMA Member Agreement. Enrollment in the JPRIMA requires execution of the JPRIMA Member Agreement as well as membership in the California Association of Mutual Water Companies (Cal Mutuals).

SECTION	COVERAGE		PREMIUM
1	PROPERTY (Including Equipment Breakdown, if granted)	\$	N/A
2	INLAND MARINE	\$	N/A
3	COMMERCIAL CRIME (Including Faithful Performance, if granted)	\$	693.00
4	COMMERCIAL GENERAL LIABILITY	\$	6,910.00
5	PUBLIC OFFICIALS & MANAGEMENT LIABILITY (Including Wrongful Acts, Employment Practices, or Employee Benefits, if granted)	\$	3,168.00
6	BUSINESS AUTO	\$	N/A
7	COMMERCIAL EXCESS LIABILITY (Including Commercial General Liability, Wrongful Acts, Employment Practices, Employee Benefits, Business Auto, and Employers Liability, if granted)	\$	4,826.00
	MEMBER CONTRIBUTION (excludes state-imposed taxes, surcharges, and fees)	\$	15,597.00
	JPRIMA ADMINISTRATION FEES	\$	1,660.00
	TOTAL AMOUNT DUE*	\$	17,257.00

*Payment is due within 30 days of the effective date.

NOTES:

The JPRIMA MOC has a common anniversary date of April 1.

The Member's FEIN number is required in order to bind coverage.

Terrorism Coverage is automatically included for Property, General Liability and Excess in most regions of CA.

Section 1. PROPERTY (Included in the proposal? No)

ISSUER:	<ul style="list-style-type: none"> ▪ California Association of Mutual Water Companies Joint Powers Risk and Insurance Management Authority (JPRIMA) ▪ No Joint and Several Liability for Members ▪ 100% Reinsured
REINSURER	<ul style="list-style-type: none"> ▪ A+ XV (Superior) A.M. Best Rating ▪ AA- Standard & Poor's Rating
FORM:	Proprietary & Integrated

LIMITS

Total Insured Values: (Real Property & Business Personal Property)	N/A
Loss of Income (aka: Business Income)	N/A
Extra Expense	N/A
Equipment Breakdown	N/A
*Flood Zone Low/Moderate <u>[N/A]</u> (Each Occurrence)	N/A

* Munich/APR cannot warrant or provide information as to what zone(s) a specific location/address is situated in. Flood zones can and do change. It is ultimately the responsibility of the member and their insurance advisor to determine if the flood zones and flood limits proposed are adequate for their needs.

DEDUCTIBLES

Property Deductible (per occurrence)	N/A	Flood Zone Low/Moderate (\$) Deductible (per occurrence)	N/A
Equipment Breakdown Deductible (per occurrence) – aboveground and less than 50 feet belowground	N/A	Flood Zone Low/Moderate (%) Deductible (per occurrence)	N/A
Equipment Breakdown Deductible (per occurrence) – greater than 50 feet belowground	N/A		

COVERED LOCATIONS:

Per Statement of Values: Blanket coverage applies unless otherwise noted.

SCHEDULE OF PROPERTY LIMITS – INDIVIDUAL LIMITS

LOC./BLDG NUM	BUILDING DESCRIPTION	BUILDING VALUE	CONTENTS VALUE	TOTAL INSURED VALUE	VALUATION	COINS. %
---------------	----------------------	----------------	----------------	---------------------	-----------	----------

COINSURANCE: N/A

POLICY HIGHLIGHTS:

- Broad Definition of Covered Property
- Option for Special Property Floater
- Form: Special Form (including Theft)
- Proprietary Coverage Extensions

VALUATION:

MEMBER: Indian Wells Valley Groundwater Authority
EFFECTIVE DATE: 4/1/2024

DISCLAIMER: Actual coverage is subject to the language of the policies as issued.
Your issued policy may contain limits, exclusions, and limitations that are not detailed in this proposal.

- Replacement Cost: Real Property & Business Personal Property (All Buildings subject to Property Valuation²)
- Actual Loss Sustained: Loss of Income (aka: Business Income)
- Optional Extended Business Income & Extra Expense (12 months or \$1,000,000, whichever is less)

²Functional Replacement Cost and/or Actual Cash Value are available for older and lower valued buildings.

SELECTED OPTIONAL COVERAGES:

KEY EXCLUSIONS:

- Earthquake & Earth Movement
- Flood (unless coverage is designated above, such coverage would be limited to locations in Zone X (Unshaded)/C only)

SPECIAL COVERAGES

Newly Acquired or Under Construction Real Property and Related Personal Property: Pays up to \$1,000,000 for your newly acquired real property or under construction “real property” intended for use in your “operations” acquired or where construction began after policy inception. This applies to “real property” you buy, lease, rent, or construction, including temporary structures. An additional \$500,000 limit of insurance applies to “personal property” located at new premises.

Equipment Breakdown³: Pays up to the limit in the declarations for direct physical damage to covered real property or personal property and loss of income sustained and extra expense incurred that is the result of an accident or electronic circuitry impairment. The most paid under any one equipment breakdown is the limit for real property and personal property for the applicable premises. The most paid for loss of income or extra expense in any one equipment breakdown is the limit of insurance shown in the declarations under C. Loss of Income and D. Extra Expense, respectively. The limits in this extension are part of and not in addition to the limits applicable in Section I – Coverages.

Under this extension, the following coverages also apply to loss caused by or directly resulting from an accident or electronic circuitry impairment. However, with respect to coverage (9) Service Interruption below, coverage will apply only to the direct result of an accident and will not apply to the direct result of an electronic circuitry impairment. The coverages described in (1) through (10) below do not provide additional amounts of insurance, they are part of and not in addition to the applicable limits of insurance:

- (1) **Data Restoration** – Pays up to your reasonable and necessary cost to research, replace and restore lost electronic data. The most we will pay for loss, damage, or expense for electronic data restoration including actual loss of income you sustain and necessary extra expense you incur is **\$500,000**.
- (2) **Expediting Expenses** – With respect to your covered real property and personal property that is damaged, we will pay the reasonable cost to make temporary repairs; and expedite permanent repairs or permanent replacement. The most we will pay for loss or expense under this coverage is **\$100,000**.
- (3) **Extra Expense** – Extra expense is extended to apply to extra expense incurred as a result of an accident or electronic circuitry impairment covered under this extension, and subject to the policy limit.
- (4) **Green** – Subject to more extensive provisions outlined in the policy, we will pay additional costs for the repair, replacement, disposal, etc. and/or damages as they relate to items associated with a recognized environmental standards program. The most we will pay for any qualifying loss, damage, or expense under this coverage, including actual loss of Business Income you sustain and any necessary Extra Expense you incur is **\$100,000**.
- (5) **Hazardous Substances** – Pays for the additional cost to repair or replace covered real property or personal property because of contamination by a hazardous substance. This includes the additional expense to clean up or dispose of such property. This does not include contamination of perishable goods by refrigerant. The most we will pay for loss, damage, or expense under this coverage, including actual loss of income you sustain and necessary extra expense you incur is **\$250,000**.
- (6) **Loss of Income** – Loss of Income is extended to apply to loss of income sustained as a result of an accident or electronic circuitry impairment covered under this extension, and subject to the policy limit as show in the Equipment Breakdown Coverage Supplemental Declarations.
- (7) **Off-Premises Equipment Breakdown** – Subject to more extensive provisions outlined in the policy, this extends coverage to apply to an accident or electronic circuitry impairment for the following types of equipment used in the member’s firefighting, ambulance or rescue operations, whether mobile/portable or permanently mounted on a vehicle, anywhere in the policy territory: 1) mobile cascade units; 2) mobile electrical generators; 3) portable pumping units; and 4) portable extrication devices, such as jaws-of-life. For equipment other than that used in your firefighting, ambulance or rescue operations, we will pay for physical damage to transportable covered equipment that, at the time of the accident or impairment is not at a covered location, among other offerings. The most we will pay is **\$25,000**.

- (8) Public Relations** – Subject to you sustaining an actual loss of income covered under this extension, this pays for reasonable costs for professional services to create and disseminate communications, when the need for such communications arises direction for the interruption of your business. Communication must be directed to the media, public, or your customers/clients/members. Costs are subject to being incurred during the period of restoration + 30 days. The most we will pay for loss or expense under this coverage is **\$5,000**.
- (9) Service Interruption** – Subject to more extensive provisions outlined in the policy, any insurance provided for loss of income, extra expense, data restoration or spoilage is extended to apply to your loss, damage, or expense caused by a failure or disruption of service.
- (10) Spoilage** – We will pay for physical damage to perishable goods due to spoilage; for physical damage to perishable goods due to contamination from the release of refrigerant; and/or any necessary expenses you incur to reduce the amount of loss under this coverage. Valuation and replacement conditions apply. The most we will pay for loss, damage or expense under this coverage is **\$100,000**.

³Please consult the exact policy language for all provisions that apply to each of the above Equipment Breakdown coverage.

Pollution Remediation Expenses: Pays up to \$25,000 (covered cause of loss) or \$100,000 (specified cause of loss) for remediation expenses incurred as a result of an actual, alleged, or threatened presence of pollution conditions at a premises described in the Declarations from a Covered Causes of Loss or Specified Cause of Loss occurring during the policy period and reported within 180 days. Covered Causes of Loss means risks of direct physical loss unless the loss is excluded or limited by the Property Coverage Form. Limits may be increased for a charge.

Specified Cause of Loss means the following: fire, lightning, windstorm or hail, explosion, riot or civil commotion, vehicles or aircraft, smoke, sonic boom, vandalism and malicious mischief, sprinkler leakage, sinkhole collapse, volcanic action, falling objects, weight of ice, snow or sleet, or water damage. Water damage means only accidental discharge or leakage of water or steam as the direct result of the breaking or cracking of any part of a system or appliance containing water or steam.

Property In Transit or Off Premises: Pays up to \$100,000 for direct physical loss or damage to covered property (real and personal property) while in transit or while temporarily off premises caused by a covered cause of loss, including your covered computer hardware while off premises.

SCADA Upgrades: Pays up to \$100,000 to upgrade your scheduled SCADA system after direct physical loss from a Covered Cause of Loss. The upgrade is in addition to its replacement cost. SCADA means the Supervisory Control and Data Acquisition system used in water and wastewater treatment and distribution to monitor leaks, waterflow, water analysis, and other measurable items necessary to maintain operations.

Unintentional Errors: Pays up to \$250,000 for any unintentional error or omission you make in determining or reporting values or in describing the covered property or covered locations.

Personal Effects: Pays up to \$25,000 for direct physical loss or damage to personal effects owned by you, your officers, managers, elected or appointed officials, employees, or volunteer workers caused by a covered cause of loss at your premises. Will pay up to "replacement cost."

Lock Replacement: Pays up to \$25,000 for lock, lock cylinder, & key replacement after theft at covered premises or damage to a lock as a result of a covered cause of loss at a covered premises. No deductible applies.

Foundations: Your real property includes foundations located at a described premise.

KEY DEFINITIONS

Covered Equipment: Means covered real property and personal property that generates, transmits, or utilizes energy or which, during normal usage, operates under vacuum or pressure, other than the weight of its contents. Covered equipment may utilize conventional design and technology or new or newly commercialized design and technology.

None of the following is covered equipment: (a) structures, foundation, cabinet or compartment; (b) insulating or refractory material; (c) sewer piping, buried vessels or piping, piping forming or part of a sprinkler or fire suppression system; (d) water piping other than boiler feedwater piping, boiler condensate return piping or water piping form as part of a refrigerating or air conditioning system; (e) vehicle or any equipment mounted on a vehicle; (f) satellite, spacecraft or any equipment mounted on a satellite or spacecraft; (g) dragline, excavation, or construction equipment; (h) equipment manufactured by you for sale; or (h) electronic data.

Electronic Circuitry: Means microelectronic components, including but not limited to circuit boards, integrated circuits, computer chips, and disk drives.

Electronic Circuitry Impairment:

- (a) Means a fortuitous event involving electronic circuitry within covered equipment to suddenly lose its ability to function as it had been functioning immediately before such event. This definition is subject to the conditions specified in (b), (c), and (d) below.
- (b) We shall determine that the reasonable and appropriate remedy to restore such covered equipment's ability to function is the replacement of one or more electronic circuitry components of the covered equipment.
- (c) The covered equipment must be owned or leased by you or operated under your control.
- (d) None of the following is an electronic circuitry impairment:
 - (i) Any condition that can be reasonably remedied by:
 - 1) Normal maintenance, including but not limited to replacing expendable parts, recharging batteries or cleaning;
 - 2) Rebooting, reloading, or updating software or firmware; or
 - 3) Providing necessary power or supply.
 - (ii) Any condition caused by or related to:
 - 1) Incompatibility of the covered equipment with any software or equipment installed, introduced, or networked within the prior 30 days; or
 - 2) Insufficient size, capability, or capacity of the covered equipment;
 - 3) Exposure to adverse environmental conditions, including but not limited to change in temperature or humidity, unless such conditions result in an observable loss of functionality. Loss of warranty shall not be considered an observable loss of functionality.

Outdoor Property: Fixed or permanent structures including but not limited to:

- › Docks, wharves, piers, pilings, or bulkheads;
- › Dumpsters, concrete trash containers, or permanent recycling bins;
- › Electric utility power transmission and distribution lines, poles and related equipment owned by the member;
- › Exterior signs not located at a premises;
- › Fences and retaining walls;
- › Historical markers and flagpoles;
- › Hydrants, not associated with a sprinkler system;
- › Lighting towers;
- › Playground equipment, park shelters, pedestrian-only bridges, picnic tables, water fountains or coolers, benches, dugouts, bleachers, or scoreboards;
- › Storage sheds, garages, pavilions, or other similar buildings or structures not located at a premises; or
- › Traffic lights, streetlights, traffic signs, parking meters, or bus shelters.

Personal Property: Means all property used in your operations other than real property, including but, not limited to:

- › Furnishings and office equipment
- › Building contents;
- › Computer equipment;
- › Communication systems;

- Materials, supplies (including your inventory of vehicle parts and supplies) while held on your premises awaiting installation;
- Base stations and dispatching systems, provided the property is on your premises and also provided you own the property, or the property is in your custody or control, and you are responsible for it, even though it belongs to someone else;
- Value of your right to use improvements made as a tenant, if you have paid for alterations or additions to any building or structure that you do not own (improvements must be at a premises).

Pollution Conditions: The discharge, dispersal, release, seepage, migration, or escape of smoke, vapors, soot, fumes, acids, alkalis, toxic chemicals, liquids or gases, hazardous materials, waste materials (including medical, infectious and pathological wastes) or electromagnetic fields into or upon land or any structures thereon, the atmosphere, or any watercourse or body of water including groundwater.

Real Property: The items at a premises described in the Declarations.

This includes:

- Aboveground piping;
- Aboveground and belowground "penstock";
- Additions under construction;
- Air cascade units that are not designed to be used off "premises";
- All appurtenant buildings or structures other than playground equipment, park shelters, pedestrian-only bridges, picnic tables, water fountains or coolers, benches, dugouts, bleachers, or scoreboards;
- Alterations and repairs to the buildings or structures;
- Completed additions;
- Exterior signs, meaning neon, automatic, mechanical, electric or other signs either attached to the outside of a building or structure, or standing free in the open;
- Foundations;
- Materials, equipment, supplies and temporary structures you own or for which you are responsible, on the "premises" or in the open (including property inside "vehicles") within 1,000 feet of the "premises", used for making additions, alterations or repairs to buildings or structures at the "premises";
- Outdoor fixtures;
- Paved surfaces such as sidewalks, bike paths, walkways, patios or parking lots;
- Permanently installed fixtures, machinery, and equipment;
- "Personal property" used for the maintenance and service of buildings or structures, including tools, lawn care equipment, and free-standing appliances for refrigerating, ventilating, cooking, dishwashing and laundering;
- Submersible pumps, pump motors and engines; or
- Underground piping located on or within 100 feet of a "premises" described in the Declarations.

Remediation Expenses: Expenses incurred for or in connection with the investigation, monitoring, removal, disposal, treatment, or neutralization of pollution conditions to the extent required by: (1) federal, state or local laws, regulations or any subsequent amendments thereof enacted to address pollution conditions; and (2) a legally executed state voluntary program governing the cleanup of pollution conditions.

Tools and Equipment: All tools and equipment, together with attached devices, accessories and trailers, that are used in your operations. Tools and equipment include, but are not limited to, hand tools, mechanics tools, power tools, meter readers, generators, air compressors, welders, trash pumps, trenchers, saws, jackhammers, maintenance or diagnostic equipment including specialized audio-visual equipment and its associated laptop, as well as recreational equipment, such as outdoor portable seating, temporary stands, food service trailers not licensed for road use, or portable restrooms.

Tools and equipment also include mobile equipment such as, but not limited to, bulldozers, mobile equipment that travels on crawler treads, tractors, loaders, backhoes, excavators, graders, or road surfacing equipment, and equipment whether self-propelled or not, maintained primarily to provide mobility to permanently mounted cranes, shovels, loaders, diggers, and drills. Tools and equipment also include snowplows, salt spreaders, and other similar equipment when not attached to a vehicle.

PROPERTY SUBLIMITS	
Coverage	Limit
Accounts Receivable	\$50,000
Arson, Theft, or Vandalism Information Reward	\$25,000
Building Glass – Tenant	Lesser of replacement cost or amount liable under contract
Claim Expense	\$20,000
Commandeered Property (RC + loss of use)	For the time you officially use the commandeered property + reasonable return time.
Damage to Building from Theft	\$100,000
Debris Removal Expenses	25% + \$100,000
Equipment Breakdown	Building + BPP Limit + Loss of Income & Extra Expense
Fine Arts	\$50,000 (appraised) \$25,000 (unappraised – subject to \$1,500/item max)
Fire Department Charges	\$25,000
Fire Extinguishing Equipment Recharge Costs	“Necessary and reasonable” (per policy)
Limited Coverage for Fungus, Wet Rot or Dry Rot	\$25,000
Lock Replacement	\$25,000
Newly Acquired or Under Construction Real Property (Coverage A) and Related Personal Property (Coverage B)	Coverage A: \$1,000,000 Coverage B: \$500,000
Non-owned Detached Trailers	\$50,000
Ordinance Coverage Coverage A: Undamaged Real Property Coverage B: Demolition Coverage C: Increased Cost	Coverage A: Limit of Insurance (applicable to that item) Coverage B and Coverage C: Greater of 100% of direct physical loss or \$1,000,000
Outdoor Property	
Personal Effects	\$25,000
Pollution Remediation Expense (covered cause of loss)	\$25,000
Pollution Remediation Expense (specified cause of loss)	\$100,000
Preservation of Property	Included
Real Property or Personal Property in Transit or Off-Premises	\$100,000
Software	\$500,000
Spoilage Due to Off Premises Electric Service Interruption	\$50,000
Supplementary Provisions for Coverage C. “Loss of Income” and Coverage D “Extra Expense”	Included
Trees, Shrubs, Plants and Lawns (max \$1,000 any one item)	\$25,000
Utility Services – Direct Damage	
Valuable Papers and Records	\$50,000
Water Contamination Notification Expense	\$25,000 (annual aggregate)

NOTES:
Property coverage is excluded.

Section 2. INLAND MARINE (Included in the proposal? No)

ISSUER:	<ul style="list-style-type: none"> ▪ California Association of Mutual Water Companies Joint Powers Risk and Insurance Management Authority (JPRIMA) ▪ No Joint and Several Liability for Members ▪ 100% Reinsured
REINSURER	<ul style="list-style-type: none"> ▪ A+ XV (Superior) A.M. Best Rating ▪ AA- Standard & Poor's Rating
FORM:	Proprietary & Integrated

LIMITS

Coverage A: Blanket Tools and Equipment: (Unscheduled, Maximum \$10,000 any one item)	N/A
Coverage B: Scheduled Equipment:	N/A
Coverage C: Blanket Emergency Services Equipment:	N/A

COVERAGE EXTENSIONS – Adds or extends the coverage under Section I – Coverages. Unless stated otherwise in the policy, a) each extension is limited to direct physical loss or damage cause by or resulting from a covered cause of loss; b) the limits in each extension are in addition to the limits applicable in Section I – Coverages; and c) All other applicable terms and conditions of the coverage form apply to each extension. (**whichever comes first)

Debris Removal Expenses	Max \$15,000 (per occurrence)
Employee Tools (no deductible applies)	Max \$25,000 (per occurrence)
Emergency Services and Law Enforcement Personal Effects (Coverage C extension, no deductible applies)	Replacement Cost
Rented or Borrowed Equipment	
<ul style="list-style-type: none"> ▪ Coverage A: Blanket Tools and Equipment and Coverage C: Blanket Emergency Services Equipment (\$1,000 deductible applies) ▪ Coverage B: Scheduled Equipment (Extended to equipment not owned by you, \$1,000 deductible applies) 	<p>**Replacement Cost or \$10,000 (per occurrence)</p> <p>**Actual Cash Value or \$N/A (per occurrence)</p>
Newly Acquired Scheduled Equipment (Coverage B extension, \$1,000 deductible applies)	30 days on Replacement Cost (not to exceed purchase price)
Personal Watercraft and Watercraft (Coverage A & C extension only)	**Replacement Cost or \$25,000 (per occurrence)
Rental Reimbursement for Scheduled Equipment (Coverage B extension, no deductible applies)	Max \$10,000 (per occurrence)
Unmanned Aircraft (\$500 deductible applies)	Max \$25,000 (per occurrence)
Fire Department Charges (no deductible applies)	Max \$1,000 (per occurrence)
Fire Extinguishing Recharge Costs (no deductible applies)	Necessary and Reasonable Costs (extinguishing equipment must be for the protection of your inland marine equipment)

DEDUCTIBLES		
Coverage A: Blanket Tools and Equipment		N/A
Coverage B: Scheduled Equipment		N/A
Coverage C: Blanket Emergency Services Equipment		N/A

POLICY HIGHLIGHTS:

- Blanket Coverages: “Tools and Equipment” and “Emergency Services Equipment”
- Suite of Coverage Extensions available in the core form.
- Deductible Waiver in certain circumstances for Coverages A & B.
- Service Animal Floater Purchased: N/A – Valuation: Agreed Value (No deductible applies)

VALUATION:

- Coverage A: Blanket Tools and Equipment: Replacement Cost
- Coverage B: Scheduled Equipment: Replacement Cost or Actual Cash Value
- Coverage C: Blanket Emergency Services Equipment: N/A

NOTES:

Inland Marine coverage is excluded.

Section 3. COMMERCIAL CRIME (Included in the proposal? Yes)

ISSUER:	<ul style="list-style-type: none"> ▪ California Association of Mutual Water Companies Joint Powers Risk and Insurance Management Authority (JPRIMA) ▪ No Joint and Several Liability for Members ▪ 100% Reinsured
REINSURER	<ul style="list-style-type: none"> ▪ A+ XV (Superior) A.M. Best Rating ▪ AA- Standard & Poor's Rating
FORM:	Proprietary & Integrated

LIMITS

Coverage Group	Employee Theft	Forgery or Alteration	Theft of Money & Securities (Inside the Premises)	Robbery or Safe Burglary (Inside the Premises)	Outside the Premises	Computer & Funds Transfer Fraud	Money Orders & Counterfeit Money
5	\$250,000	\$250,000	\$250,000	\$100,000	\$250,000	\$250,000	\$250,000

DEDUCTIBLE

\$1,000 (each claim)

POLICY HIGHLIGHTS:

Separate Limits Apply to Each Coverage
 Broad Definition of Employee
 Non-auditable
 Faithful Performance of Duty

NOTES:

Fraudulent Impersonation is excluded.

Section 4. COMMERCIAL GENERAL LIABILITY (Included in the proposal? Yes)

ISSUER:	<ul style="list-style-type: none"> ▪ California Association of Mutual Water Companies Joint Powers Risk and Insurance Management Authority (JPRIMA) ▪ No Joint and Several Liability for Members ▪ 100% Reinsured
REINSURER	<ul style="list-style-type: none"> ▪ A+ XV (Superior) A.M. Best Rating ▪ AA- Standard & Poor's Rating
FORM:	Proprietary & Integrated

LIMITS

General Aggregate	\$10,000,000
Products & Completed Operations Aggregate	\$10,000,000
Each Occurrence	\$1,000,000
Personal & Advertising Injury Limit	\$1,000,000
Damage to Premises Rented to You	\$1,000,000
Medical Payments	\$10,000

DEDUCTIBLE

\$5,000 Per Occurrence or Offense including expenses

SELECTED OPTIONAL COVERAGES

Hired/Non-Owned Auto Liability
Failure to Supply Liability

POLICY HIGHLIGHTS:

- Duty to Defend w/ Defense Costs In Addition to Limits
- Broad Definition of Enrolled Named Member – including, but not limited to Employees, Volunteers, Elected or Appointed Officials
- Host Liquor Liability, Unless Otherwise Excluded
- Owned (Up to 100 HP – higher available by endorsement) & Nonowned Watercraft
- Blanket Additional Enrolled Named Member
- Water & Wastewater Testing Errors and Omissions
- Failure to Supply (No ISO limitation)
- Lead (potable water)
- Waterborne Asbestos (potable water)
- Product Recall
- Impaired Property
- Fungi & Bacteria
- Non-auditable

SPECIAL COVERAGES

Asbestos: Exclusion exception wherein coverage is provided for bodily injury or property damage arising out of potable water which is supplied to others.

Contractual Liability - Railroads: Coverage is provided for any contract or agreement that indemnifies a railroad for bodily injury or property damage arising out of construction or demolition operations, within 50 feet of any railroad property and affecting any railroad bridge or trestle, tracks, road-beds, tunnel, underpass or crossing. Available via endorsement only.

Damage to Impaired Property or Property Not Physically Injured: Exclusion exception wherein the Damage to Impaired Property or Property Not Physically Injured exclusion does not apply to potable water, non-potable water, or wastewater as well as any loss of use of other property arising out of a sudden and accidental physical injury to the member's product or work after it has been put to its intended use.

Failure to Supply: Coverage is provided for bodily injury or property damage arising out of the failure of any member to adequately supply water.

Fungi or Bacteria: Exclusion exception wherein the Fungi or Bacteria exclusion does not apply to a) any fungi or bacteria that are on or are contained in a good or product intended for consumption; or b) any injury or damage arising out of or caused by your water, irrigation, or wastewater intake, outtake, reclamation, treatment, or distribution process.

Lead: Exclusion exception to Lead, Electromagnetic Radiation, Nuclear exclusion that creates an exception for potable water you supply to others for claims involving the toxic properties of lead, or any material or substance containing lead.

Recall of Products, Work or Impaired Property: Exclusion exception where in the Recall of Products, Work or Impaired Property exclusion does not apply to potable water, non-potable water, or wastewater.

Pollution: The pollution exclusion contains the following exceptions:

- To bodily injury if sustained within a building owned or occupied by a member and caused by smoke, fumes, vapor, or soot if produced or originating from certain equipment.
- To bodily injury or property damage arising out of heat, smoke, fumes from a hostile fire occurring or originating from certain premises, sites, or locations as outlined in the policy.
- To bodily injury or property damage that occurs as a result of your operations (unless otherwise specifically excluded) including:
 - › Potable water supplied to others;
 - › Chemicals used in your water/wastewater treatment process;
 - › Chemicals you use, apply or store for your ownership, maintenance, or operation of swimming pools;
 - › The use, application or storage of road salt or similar substances designed and used for snow/ice removal;
 - › Natural gas or propane gas you use in your water or wastewater treatment process;
 - › Urgent response for the protection of property, human life, health or safety conducted away from premises you own, rent or occupy;
 - › Training operations;
 - › Water runoff from the cleaning of equipment use in emergency service activities;
 - › Storage or application of pesticides/herbicides if such storage or application meets all standards of any statute, ordinance, regulation or license requirement of any federal, state or local government; or
 - › Fuels, lubricants or other operating fluids needed to perform the normal electrical, hydraulic or mechanical functions necessary for the operation of "mobile equipment" subject to additional policy terms.
- › To bodily injury or property damage if such bi/pd is caused by the escape of back-up of sewage or wastewater from any sewage treatment facility or fixed conduit that you own, operate, lease, control.
- › This coverage applies only to a short-term pollution event reported within 14 days after ending and the discharge is accidental, unintended, and stopped asap.

Water & Wastewater Testing Errors and Omissions: Coverage is provided for damages arising out of an act, error, or omission which arises from your water or wastewater testing.

Who is Covered: Coverage is extended to Scheduled Named Members comprising individuals, spouses, partnerships, joint ventures, corporations, trusts, limited liability companies, public entities, operating authorities, boards, commissions, districts, governmental units, nonprofit entities, and other organizations. Members also include: elected or appointed officials; employees or volunteer workers; real estate managers; temporary custodians; legal representatives; medical directors;

mutual aid agreements; Good Samaritans; owners of commandeered equipment; blanket additional enrolled named members; and newly acquired or formed entities.

KEY DEFINITIONS

Insured (Member) Contract:

- › A contract for a lease or premises (see full terms and conditions).
- › A sidetrack agreement;
- › Any easement or license agreement, except in connection with construction or demolition operations on or within fifty (50) feet of a railroad;
- › An obligation, as required by ordinance, to indemnify a municipality, except in connection with work for a municipality;
- › An elevator maintenance agreement;
- › That part of any other contract or agreement pertaining to your operations (including an indemnification of a municipality in connection with work performed for a municipality) under which you assume the tort liability of another party to pay for bodily injury or property damage to a third person or organization (see full terms and conditions).

Suit: Means a civil proceeding in which damages because of bodily injury, property damage, personal and advertising injury, medical incident, law enforcement wrongful act, or a water or wastewater professional activity to which this insurance applies are alleged. Suit includes: a) An arbitration proceeding in which such damages are claimed and to which the member must submit or does submit with our consent; or 2) Any other civil alternative dispute resolution proceeding in which such damages are claimed and to which the member submits with our consent.

NOTES:

Section 5. PUBLIC OFFICIALS & MANAGEMENT LIABILITY (Included in the proposal? Yes)

ISSUER:	<ul style="list-style-type: none"> ▪ California Association of Mutual Water Companies Joint Powers Risk and Insurance Management Authority (JPRIMA) ▪ No Joint and Several Liability for Members ▪ 100% Reinsured
REINSURER	<ul style="list-style-type: none"> ▪ A+ XV (Superior) A.M. Best Rating ▪ AA- Standard & Poor's Rating
FORM:	Proprietary & Integrated

LIMITS

Coverage A: Wrongful Acts - Employment Practices - Employee Benefits Liability	\$	1,000,000 Excluded Excluded	Each Wrongful Act or Offense
Coverage B: Injunctive Relief	\$	5,000	Each Action
Aggregate Limit	\$	10,000,000	Coverage A & B Combined

WRONGFUL ACTS DEDUCTIBLE	EMPLOYMENT PRACTICES DEDUCTIBLE
\$5,000 (each Wrongful Act or Offense Including Expenses)	N/A (each Wrongful Act or Offense Including Expenses)
WRONGFUL ACTS RETROACTIVE DATE (CLAIMS-MADE)	EMPLOYMENT PRACTICES RETROACTIVE DATE (CLAIMS-MADE)
N/A	N/A

EMPLOYEE BENEFITS LIABILITY RETROACTIVE DATE (CLAIMS-MADE)
N/A

POLICY HIGHLIGHTS:

- Duty To Defend
- Broad Definition of Named Enrolled Named Member
- Third Party Offense Coverage
- Non-auditable

SELECTED OPTIONAL COVERAGES:

KEY DEFINITIONS

Employment Practices: Injury, including consequential bodily injury, arising from any of your employment practices including, but not limited to:

- › Discrimination;
- › Harassment;
- › Retaliation;
- › Any actual or alleged wrongful dismissal, discharge, or termination (either actual or constructive) of employment, including breach of an implied employment contract or an implied covenant of good faith and fair dealing in an employment contract;
- › Any actual or alleged wrongful hiring, demotion, discipline, evaluation, supervision and investigation of an employee or intentional interference with an employment contract;
- › Any actual or alleged wrongful deprivation of a career opportunity, to promote an employee or the wrongful failure to employ;
- › Any actual or alleged false arrest, false imprisonment, false detention or malicious prosecution, liable, slander, defamation, disparagement or invasion of the right of privacy, as respects employment practices;

- The violation of any federal, state, or local statutes, rules or regulations applicable to employers;
- The development, implementation, and enforcement of any and all practices, policies and procedures governing any aspect of employment practices;

Injunctive or Declaratory Relief: (a) means equitable relief sought through the demand for the issuance of a permanent, preliminary, or temporary injunction, restraining order, or similar prohibitive write against, or order for specific performance by, a member; or (b) any request that a court make a finding of law or fact, provided such action is filed during the policy period.

Wrongful Act: means any actual or alleged error, act, omission, neglect, misfeasance, nonfeasance, or breach of duty, including violation of any civil rights law, by any member in discharge of their duties individually or collectively that results directly but unexpectedly and unintentionally in damages to others.

NOTES:

Section 6. BUSINESS AUTO (Included in the proposal? No)

ISSUER:	<ul style="list-style-type: none"> ▪ California Association of Mutual Water Companies Joint Powers Risk and Insurance Management Authority (JPRIMA) ▪ No Joint and Several Liability for Members ▪ 100% Reinsured
REINSURER	<ul style="list-style-type: none"> ▪ A+ XV (Superior) A.M. Best Rating ▪ AA- Standard & Poor's Rating
FORM:	Proprietary & Integrated

PORTFOLIO

Coverage	Symbol	Limit
Combined Single Limit for Bodily Injury & Property Damage (each accident)	N/A	N/A
Hired Auto Liability	N/A	N/A
Non-Owned Auto Liability	N/A	N/A
Medical Payments	N/A	N/A
Uninsured / Underinsured Motorists	N/A	N/A
Hired Physical Damage	N/A	N/A
Physical Damage – Comprehensive	N/A	N/A
Physical Damage – Collision	N/A	N/A

DEDUCTIBLE

Liability:	N/A (per accident)
Comprehensive:	N/A (each covered auto)
Collision:	N/A (each covered auto)

FLEET COVERAGE ENHANCEMENTS & COVERAGE EXTENSIONS (As Applicable)

- › Fleet Automatic Coverage
- › Commercial Auto 360 Endorsement
- › Pollution Liability – Broadened Coverage for Covered Autos

NOTES:

Auto coverage is excluded. Please refer to General Liability section for Hired and Non-Owned Auto Liability coverage.

Section 7. COMMERCIAL EXCESS LIABILITY (Included in the proposal? Yes)

ISSUER:	<ul style="list-style-type: none"> ▪ California Association of Mutual Water Companies Joint Powers Risk and Insurance Management Authority (JPRIMA) ▪ No Joint and Several Liability for Members ▪ 100% Reinsured
REINSURER	<ul style="list-style-type: none"> ▪ A+ XV (Superior) A.M. Best Rating ▪ AA- Standard & Poor's Rating
FORM:	Proprietary & Integrated

LIMITS

\$5,000,000/\$5,000,000

SCHEDULED UNDERLYING COVERAGE FORMS

Commercial General Liability – Included

Auto Liability – Excluded

Public Officials & Management Liability (Wrongful Acts) – Included

Employers' Liability: (minimum underlying limit requirement of \$500,000 / \$500,000 / \$500,000) – Excluded

Other:

NOTABLE COVERAGES INCLUDED IN THE EXCESS (require minimum underlying limits of \$1,000,000)

Law Enforcement Liability (General Liability) – Excluded

Hired and Non-Owned Auto Liability (General Liability) – Included

Abuse and Molestation Coverage (General Liability) - Excluded

Employee Benefit Plans (General Liability) – Excluded

Inverse Condemnation (General Liability) – Excluded

Hired and Non-Owned Auto Liability (Owned Auto) – Excluded

Employment Practices (POML) – Excluded

Employee Benefit Plans (POML) – Excluded

Inverse Condemnation (POML) – Excluded

NOTABLE EXCLUSIONS:

- Workers' Compensation
- Uninsured Motorists / Underinsured Motorists
- Underlying Limits < \$1,000,000 except for Employer's Liability

NOTES:

Employers' Liability subject to MRSI security requirements.

Please provide a copy of the current W/C declarations for review and affirmation of coverage.

Section 8. UNDERWRITING SUBJECTIVITIES AND GENERAL NOTES

ISSUER:	<ul style="list-style-type: none"> ▪ California Association of Mutual Water Companies Joint Powers Risk and Insurance Management Authority (JPRIMA) ▪ No Joint and Several Liability for Members ▪ 100% Reinsured
REINSURER:	<ul style="list-style-type: none"> ▪ A+ XV (Superior) A.M. Best Rating ▪ AA- Standard & Poor's Rating
FORM:	Proprietary & Integrated
MEMBER:	Indian Wells Valley Groundwater Authority

GENERAL NOTES

QUOTE SUBJECTIVITIES:

THE FOLLOWING ITEMS ARE DUE AT THE TIME OF BINDING:

- ▶ Signed and Dated Public Entity Application and Member FEIN # (required to bind auto).
- ▶ Terrorism: This coverage is included in most jurisdictions (all but 8) without an associated charge for Package (Property/GL). In those instances, a signed selection/rejection is **not** required. In the 8 jurisdictions with an associated charge including the entire State of California for Excess, a signed selection/rejection form is required to be returned at the time of binding.
- ▶ Signed and Dated Uninsured/Underinsured Motorist Selection/Rejection Form.
- ▶ Copy of the latest Dam Inspection reports and member response to any inspection deficiencies, if applicable and not already provided.
- ▶ Signed Statement of Values (Property, Inland Marine and Auto, as applicable).
- ▶ Provide Name, Phone Number, and Email Address for both the Risk Manager and Boiler & Machinery Inspection contacts.
- ▶ Provide a complete driver schedule including name, date of birth, and license number.

MEMBER: Indian Wells Valley Groundwater Authority
EFFECTIVE DATE: 4/1/2024

DISCLAIMER: Actual coverage is subject to the language of the policies as issued.
 Your issued policy may contain limits, exclusions, and limitations that are not detailed in this proposal.



A D J U S T E R S , I N C

• CLAIMS ADMINISTRATORS • ADJUSTERS • INVESTIGATORS

Stanford Place I - 8055 East Tufts Avenue, Suite 600, Denver, CO 80237 – Ph: 877-533-1211

CLAIM CALL CENTER

**8055 E. Tufts Ave
Suite 600
Denver, CO 80237**

877-533-1211

**Adam Beltz– Ext 765
Reyleen Wood Ext 699
J. Mayer – Ext 664**

**Karen Zapata – Ext. 326
Subrogation Supervisor**

TO REPORT A NEW CLAIM OR LOSS

- **PHONE** **877-533-1211 Option 3
24 Hour Call Center**

- **E-MAIL** **networknewloss@networkadjusters.com**

Broker Fee Disclosure

This document outlines the fees associated with the brokerage services provided by INSURICA to the client, Indian Wells Valley Groundwater Authority. The client acknowledges and agrees to the following fee structure for the services provided:

1. Broker Fee: \$ \$750.00
 - Description: This fee covers administrative costs associated with managing the client's insurance portfolio and may include processing, policy issuance, and other administrative tasks.

The client acknowledges that the fees disclosed above are part of the compensation structure for the brokerage services rendered. The client may request further details regarding the fee structure at any time.

Insured:

Signed: _____ Date: _____

Name: _____ Title: _____

Broker:

Signed: _____ Date: _____

Name: Daren Griswold

The page intentionally blank



Invoice

Indian Wells Valley Groundwater Authority
 Ms. Carol Thomas-Keefer
 100 W. California Ave.
 Ridgecrest, CA 93555

Invoice Number: 2652-78
Invoice Date: 03/07/24

Project #: 2652 **Indian Wells Valley Groundwater Authority**

Professional Services through 1/31/2024

Water Resources Management 2024

01 - Meetings & Prep

Professional Services	<u>Bill Hours</u>	<u>Bill Rate</u>	<u>Charge</u>
Principal	9.00	\$244.00	\$2,196.00
Special Project Director	1.25	\$244.00	\$305.00
Supervisor I	11.50	\$212.00	\$2,438.00
Senior III	6.50	\$138.00	\$897.00
Associate III	3.75	\$114.00	\$427.50
Assistant I	53.75	\$101.00	\$5,428.75
Assistant II	10.00	\$96.00	\$960.00
<i>Professional Services Subtotal:</i>			<u>\$12,652.25</u>

Reimbursables	<u>Charge</u>
Reproduction (Color)	\$0.89
Reproduction	\$0.15
<i>Reimbursables Subtotal:</i>	
	<u>\$1.04</u>
<i>Meetings & Prep Subtotal:</i>	
	<u>\$12,653.29</u>

02 - Prop 1 / Prop 68 Grant Administration

Professional Services	<u>Bill Hours</u>	<u>Bill Rate</u>	<u>Charge</u>
Senior III	2.25	\$138.00	\$310.50
<i>Professional Services Subtotal:</i>			<u>\$310.50</u>
<i>Prop 1 / Prop 68 Grant Administration Subtotal:</i>			<u>\$310.50</u>

02.01 - SGMA IP Grant Administration

Professional Services	<u>Bill Hours</u>	<u>Bill Rate</u>	<u>Charge</u>
Senior III	14.00	\$138.00	\$1,932.00
Assistant I	13.00	\$101.00	\$1,313.00
Administrative I	2.00	\$74.00	\$148.00
<i>Professional Services Subtotal:</i>			<u>\$3,393.00</u>
<i>SGMA IP Grant Administration Subtotal:</i>			<u>\$3,393.00</u>

02.02 - Urban Community Drought Relief Funding Administration

Professional Services	<u>Bill Hours</u>	<u>Bill Rate</u>	<u>Charge</u>
Senior III	0.50	\$138.00	\$69.00
Assistant I	3.00	\$101.00	\$303.00
<i>Professional Services Subtotal:</i>			<u>\$372.00</u>
<i>Urban Community Drought Relief Funding Administration Subtotal:</i>			<u>\$372.00</u>

03 - Grant Review & Application Preparation



03 - Grant Review & Application Preparation

Professional Services	<u>Bill Hours</u>	<u>Bill Rate</u>	<u>Charge</u>
Supervisor I	0.75	\$212.00	\$159.00
Supervisor II	2.00	\$197.00	\$394.00
<i>Professional Services Subtotal:</i>			<u>\$553.00</u>
<i>Grant Review & Application Preparation Subtotal:</i>			<u>\$553.00</u>

04 - Data Mgmt System Support

Professional Services	<u>Bill Hours</u>	<u>Bill Rate</u>	<u>Charge</u>
Special Project Director	0.25	\$244.00	\$61.00
Senior III	3.25	\$138.00	\$448.50
Senior Associate	2.25	\$132.00	\$297.00
<i>Professional Services Subtotal:</i>			<u>\$806.50</u>
<i>Data Mgmt System Support Subtotal:</i>			<u>\$806.50</u>

05 - General Project Mgmt

Professional Services	<u>Bill Hours</u>	<u>Bill Rate</u>	<u>Charge</u>
Supervisor II	3.00	\$197.00	\$591.00
Senior III	1.25	\$138.00	\$172.50
Senior Associate	0.25	\$132.00	\$33.00
<i>Professional Services Subtotal:</i>			<u>\$796.50</u>
<i>General Project Mgmt Subtotal:</i>			<u>\$796.50</u>

06 - Model Transfer & Upgrade

Professional Services	<u>Bill Hours</u>	<u>Bill Rate</u>	<u>Charge</u>
Special Project Director	5.00	\$244.00	\$1,220.00
Supervisor I	5.00	\$212.00	\$1,060.00
Supervisor II	26.00	\$197.00	\$5,122.00
Senior III	1.25	\$138.00	\$172.50
GIS Manager	15.00	\$126.00	\$1,890.00
Assistant II	4.50	\$96.00	\$432.00
<i>Professional Services Subtotal:</i>			<u>\$9,896.50</u>

Sub-Contractors	<u>Charge</u>
Board of Regents	\$13,918.00
<i>Sub-Contractors Subtotal:</i>	
<u>\$13,918.00</u>	
<i>Model Transfer & Upgrade Subtotal:</i>	
<u>\$23,814.50</u>	

07.01 - Imported Water: Planning/Design/Environmental

Professional Services	<u>Bill Hours</u>	<u>Bill Rate</u>	<u>Charge</u>
Principal	21.00	\$244.00	\$5,124.00
Supervisor I	37.25	\$212.00	\$7,897.00
Associate III	1.25	\$114.00	\$142.50
Assistant I	103.00	\$101.00	\$10,403.00
<i>Professional Services Subtotal:</i>			<u>\$23,566.50</u>

Reimbursables	<u>Charge</u>
Data	\$575.00
<i>Reimbursables Subtotal:</i>	
<u>\$575.00</u>	
<i>Imported Water: Planning/Design/Environmental Subtotal:</i>	
<u>\$24,141.50</u>	

08 - Imported Water: Negotiations & Coordination

Professional Services	<u>Bill Hours</u>	<u>Bill Rate</u>	<u>Charge</u>
------------------------------	-------------------	------------------	---------------



08 - Imported Water: Negotiations & Coordination

Professional Services

	<u>Bill Hours</u>	<u>Bill Rate</u>	<u>Charge</u>
Supervisor I	1.25	\$212.00	\$265.00
			<u>Professional Services Subtotal:</u>
			\$265.00

Imported Water: Negotiations & Coordination Subtotal: \$265.00

09 - Recycled Water

Professional Services

	<u>Bill Hours</u>	<u>Bill Rate</u>	<u>Charge</u>
Assistant II	8.50	\$96.00	\$816.00
			<u>Professional Services Subtotal:</u>
			\$816.00

Recycled Water Subtotal: \$816.00

11 - Data Collection, Monitoring & Data Gaps

Professional Services

	<u>Bill Hours</u>	<u>Bill Rate</u>	<u>Charge</u>
Special Project Director	0.50	\$244.00	\$122.00
Supervisor I	0.25	\$212.00	\$53.00
Supervisor II	5.00	\$197.00	\$985.00
Senior Associate	19.50	\$132.00	\$2,574.00
Associate I	1.50	\$129.00	\$193.50
Senior Associate	3.00	\$128.00	\$384.00
Associate I	3.00	\$126.00	\$378.00
Associate III	25.50	\$114.00	\$2,907.00
			<u>Professional Services Subtotal:</u>
			\$7,596.50

Reimbursables

	<u>Charge</u>
Equipment Purchase	\$319.37
Mileage	\$7.30
Other Expenses	\$47.00
<u>Reimbursables Subtotal:</u>	
\$373.67	

Data Collection, Monitoring & Data Gaps Subtotal: \$7,970.17

14 - Production Reporting, Transient Pool & Fee Support

Professional Services

	<u>Bill Hours</u>	<u>Bill Rate</u>	<u>Charge</u>
Principal	3.50	\$244.00	\$854.00
			<u>Professional Services Subtotal:</u>
			\$854.00

Production Reporting, Transient Pool & Fee Support Subtotal: \$854.00

18.1 - Navy/Coso Cooperative Agreement

Professional Services

	<u>Bill Hours</u>	<u>Bill Rate</u>	<u>Charge</u>
Special Project Director	1.25	\$244.00	\$305.00
			<u>Professional Services Subtotal:</u>
			\$305.00

Navy/Coso Cooperative Agreement Subtotal: \$305.00

20 - Shallow Well Mitigation Program: Outreach & Impacts Evaluation

Professional Services

	<u>Bill Hours</u>	<u>Bill Rate</u>	<u>Charge</u>
Principal	6.50	\$244.00	\$1,586.00
Supervisor I	5.75	\$212.00	\$1,219.00
GIS Manager	0.75	\$126.00	\$94.50
Assistant I	10.00	\$101.00	\$1,010.00
			<u>Professional Services Subtotal:</u>
			\$3,909.50

Shallow Well Mitigation Program Outreach & Impacts Evaluation Subtotal: \$3,909.50

21 - General Engineering



21 - General Engineering

Professional Services

	<u>Bill Hours</u>	<u>Bill Rate</u>	<u>Charge</u>
Special Project Director	7.00	\$244.00	\$1,708.00
Supervisor I	3.25	\$212.00	\$689.00
Senior III	1.75	\$138.00	\$241.50
GIS Manager	0.50	\$126.00	\$63.00
Associate III	1.25	\$114.00	\$142.50
Assistant II	3.00	\$96.00	\$288.00

Professional Services Subtotal: \$3,132.00

General Engineering Subtotal: \$3,132.00

22 - GSP 5-Year Update

Professional Services

	<u>Bill Hours</u>	<u>Bill Rate</u>	<u>Charge</u>
Principal	1.50	\$244.00	\$366.00
Special Project Director	1.00	\$244.00	\$244.00
Supervisor I	8.25	\$212.00	\$1,749.00
Supervisor II	121.00	\$197.00	\$23,837.00
Senior III	16.50	\$138.00	\$2,277.00
Senior Associate	3.00	\$132.00	\$396.00
Associate III	9.25	\$114.00	\$1,054.50
Assistant II	57.00	\$96.00	\$5,472.00
Technical Illustrator	12.00	\$91.00	\$1,092.00

Professional Services Subtotal: \$36,487.50

GSP 5-Year Update Subtotal: \$36,487.50

23 - Annual Report Preparation

Professional Services

	<u>Bill Hours</u>	<u>Bill Rate</u>	<u>Charge</u>
Principal	1.50	\$244.00	\$366.00
Supervisor I	0.50	\$212.00	\$106.00
Senior III	5.00	\$138.00	\$690.00
GIS Manager	7.50	\$126.00	\$945.00
Associate III	1.00	\$114.00	\$114.00

Professional Services Subtotal: \$2,221.00

Annual Report Preparation Subtotal: \$2,221.00

26 - Budget Support

Professional Services

	<u>Bill Hours</u>	<u>Bill Rate</u>	<u>Charge</u>
Senior III	1.50	\$138.00	\$207.00

Professional Services Subtotal: \$207.00

Budget Support Subtotal: \$207.00

27 - Litigation Support

Professional Services

	<u>Bill Hours</u>	<u>Bill Rate</u>	<u>Charge</u>
Principal	19.00	\$244.00	\$4,636.00
Special Project Director	2.25	\$244.00	\$549.00
Supervisor I	1.00	\$212.00	\$212.00

Professional Services Subtotal: \$5,397.00

Litigation Support Subtotal: \$5,397.00

Water Resources Management 2024 Subtotal: \$128,404.96



Project #: 2652

Invoice No: 2652-78

March 07, 2024

Page 5

***** Invoice Total *****

\$128,404.96

The page intentionally blank



PO Box 1350
Carmel Valley, CA 93924

Invoice

Date	Invoice #
1/31/2024	16285

Bill To:
Indian Wells Valley Groundwater Authority 100 W California Ave Ridgecrest, CA 93555

P.O. No.	Due Date	Inv Sent
	3/1/2024	2/15/2024

Date	Description	Amount
1/31/2024	Contract Services for January - please see attached	21,500.25

Electronic Payment Information: Five Star Bank Routing: 121143037 Account: 003528782	Total \$21,500.25
---	---------------------------------

Indian Wells Valley

Month: **January, 2024**

Hours and Rates by Pay Period					
	1st -15th		16th - EOM		Monthly
Advisor	Reg Hrs	Bill Rate	Reg Hrs	Bill Rate	Total Billed
CT	15.50	\$ 134.00	11.00	\$ 134.00	\$ 3,551.00
AK	70.50	\$ 105.00	81.20	\$ 105.00	\$ 15,928.50
JK	0.00	\$ -	0.00	\$ -	\$ -
GL	0.00	\$ -	0.00	\$ -	\$ -
AM	0.00	\$ -	0.00	\$ -	\$ -
GS	10.50	\$ 137.00	4.25	\$ 137.00	\$ 2,020.75
EF	0.00	\$ -	0.00	\$ -	\$ -
RM	0.00	\$ -	0.00	\$ -	\$ -
Totals	96.50		96.45		\$ 21,500.25

The page intentionally blank



PO Box 1350
Carmel Valley, CA 93924

Invoice

Date	Invoice #
1/31/2024	16286

Bill To:
IWVGA Web Design

P.O. No.	Due Date	Inv Sent
	3/1/2024	2/15/2024

Date	Description	Amount
1/31/2024	Contract Services for January - please see attached	112.50

Electronic Payment Information: Five Star Bank Routing: 121143037 Account: 003528782	Total	\$112.50
---	--------------	-----------------

IWVGA Web Design

Month: **January, 2024**

Hours and Rates by Pay Period					
	1st -15th		16th - EOM		Monthly
Advisor	Reg Hrs	Bill Rate	Reg Hrs	Bill Rate	Total Billed
CD	0.50	\$ 150.00	0.25	\$ 150.00	\$ 112.50
AM	0.00	\$ -	0.00	\$ -	\$ -
	0.00	\$ -	0.00	\$ -	\$ -
Totals	0.50		0.25		\$ 112.50

The page intentionally blank



PO Box 1350
Carmel Valley, CA 93924

Invoice

Date	Invoice #
1/31/2024	16402

Bill To:

Indian Wells Valley Groundwater Authority
100 W California Ave
Ridgecrest, CA 93555

P.O. No.	Due Date	Inv Sent
	3/15/2024	2/28/2024

Date	Description	Amount
1/31/2024	Reimbursable Expenses for City of Ridegecrest Monthly Rent and Buraglio (\$300+92.81+80.00) - please see attached	472.81

Electronic Payment Information: Five Star Bank Routing: 121143037 Account: 003528782	Total	\$472.81
---	--------------	-----------------

The page intentionally blank



Capitol Core Group, Inc.
 205 Cartwheel Bend (Operations Dept.)
 Austin, TX 78738 US
 512.568.3084
 operations@capitolcore.com
 www.capitolcore.com

BILL TO

Indian Wells Valley Groundwater Authority
 500 West Ridgecrest Blvd.
 Ridgecrest, California 93555
 USA

SHIP TO

Indian Wells Valley Groundwater Authority
 500 West Ridgecrest Blvd.
 Ridgecrest, California 93555
 USA

INVOICE 2024-024

DATE 03/01/2024 **TERMS** Net 45

DUE DATE 04/15/2024

DATE	ACCOUNT SUMMARY	AMOUNT
02/02/2024	Balance Forward	16,387.50
	Other payments and credits after 02/02/2024 through 02/29/2024	0.00
03/01/2024	Other invoices from this date	0.00
	New charges (details below)	16,787.50
	Total Amount Due	33,175.00

ACTIVITY	HOURS	RATE	AMOUNT
Charges			
Project 1: Imported Water Supplies			
P1-A: Ongoing Supply Negotiations:			
Government Relations: Intergovernmental Affairs Ongoing Negotiations with Public Agency #2 {Tatum}	3	275.00	825.00
Government Relations: Intergovernmental Affairs Ongoing Negotiations with Public Agency Seller #4 {Tatum}	4.50	275.00	1,237.50
Government Relations: Intergovernmental Affairs Negotiations: Public Agency Seller #2	1.50	250.00	375.00
P1-B: Other Required Agreements:			
Government Relations: Intergovernmental Affairs Interconnection Agreement: Internal discussions re: Water District connection, AVEK interconnection requirements and discussion w/ AVEK {Tatum}	2	275.00	550.00
P1-C: Required Regulatory Approvals:			
Government Relations: Intergovernmental Affairs Negotiation Call Update, SGMA-IP Research and client strategy call {Simonetti}	2.50	250.00	625.00
P1-D: 2024 Water Marketing Activities			
Government Relations: Intergovernmental Affairs 2024 Water Supply Discussions with sellers {Tatum}	3	275.00	825.00
Government Relations: Intergovernmental Affairs Water Supplies Memorandum and 2024 Calls	4	250.00	1,000.00

ACTIVITY	HOURS	RATE	AMOUNT
Government Relations: Intergovernmental Affairs Negotiations w/ Public Agency Seller #4 {Simonetti}	1	250.00	250.00
Invoice Total Project 1: \$5,687.50			
Project 2: Interconnection Pipeline Project			
Government Relations: California Legislative: Revision of State Budget Request and Completion of Packet for Submittal {McKinney}	2.75	275.00	756.25
Government Relations: Federal Congressional: House Transportation & Infrastructure Committee/Senate Environment & Public Works Committee, follow-up with Senator Padilla, Rep. Garcia: HR 7065 Rep. Napolitano WRDA-24 Senate Hearing and internal calls {McKinney}	3.50	275.00	962.50
Government Relations: California Legislative: State Budget Request Review {Simonetti}	1	250.00	250.00
Government Relations: Federal Congressional: DC Briefing Documents; meeting scheduling and initial office briefings	3.25	250.00	812.50
Invoice Total Project 2: \$2,781.25			
Project 3: Other Projects Supporting the GSP			
P3-A: Water Recycling			
P3-B: Wastewater Treatment			
P3-C: Well Mitigation, Consolidation, and Repurposing			
P3-D: Government Affairs			
Government Relations: Federal Congressional: Completion of FY2025 E&WD Community Project Funding Request Packet {McKinney}	1.50	275.00	412.50
Government Relations: California Legislative: Legislative Proposal Development	2.25	275.00	618.75
Government Relations: California Legislative: AB 560, AB 1827, AB 2079, AB 2799, AB 2962, SB 1156, SB 1210 analysis and direct advocacy {McKinney}	3.50	275.00	962.50
Government Relations: California Legislative: Identification, Tracking and Analysis -- February Deadline {McKinney}	3	275.00	825.00
Government Relations: Federal Congressional: Internal strategy discussion March legislative visit {McKinney}	1.50	275.00	412.50
Government Relations: Federal Congressional: FY2025 E&WD Community Project Funding Request review {Simonetti}	1	250.00	250.00
Government Relations: Federal Congressional: Direct Advocacy House -- FY2025 E&WD	2	250.00	500.00
Government Relations: California Legislative: Pending Legislative Call {Simonetti}	1.50	250.00	375.00
Government Relations: California Legislative: Direct Advocacy Multiple Bills {Simonetti}	2.75	250.00	687.50
Invoice Total Project 3: \$5,043.75			
Project Administration			

ACTIVITY	HOURS	RATE	AMOUNT
General Business Items:Project Administration Board Meeting: February Board Meeting and Preparation {McKinney}	3	275.00	825.00
General Business Items:Project Administration Board Meeting: February Board Meeting {Tatum}	3	275.00	825.00
General Business Items:Project Administration Ad Hoc: Ridgecrest local presentation {Simonetti}	2	250.00	500.00
General Business Items:Project Administration Ad Hoc: Various Reports and Memoranda {Simonetti}	1.50	250.00	375.00
General Business Items:Project Administration Board Meetings: February Board Meeting	3	250.00	750.00
Invoice Total Project Administration: \$3,275.00			

Regulatory Compliance Notes:			
Invoice Total Federal: \$3,350.00			
Invoice Total State: \$4,475.00			

Thank you for your business. Please make checks payable to Capitol Core Group, Inc.

SUBTOTAL	16,787.50
TAX	0.00
TOTAL	16,787.50
TOTAL OF NEW CHARGES	16,787.50

TOTAL DUE	\$33,175.00
------------------	--------------------

The page intentionally blank

The page intentionally blank

PROVOST & PRITCHARD CONSULTING GROUP

455 W Fir Ave • Clovis, CA 93611 • (559) 449-2700
www.provostandpritchard.com

April Keigwin
Indian Wells Valley Groundwater Authority
100 West California Avenue
Ridgecrest, CA 93555

February 28, 2024
Project No: 04101-23-001
Invoice No: 107836

Project Name: Indian Wells Valley Groundwater Authority-CEQA/NEPA Documents and Permit Documentation

Client Project #:

TSK 1 Initial Coordination: Continued Coordination tasks with staff, client, and agencies to keep project schedule on track. Administrative tasks for overall project progression. Weekly coordination meetings and tasks for project progression. Coordination meetings with sub consultants. Internal management meetings for project progression discussions, staff changes, and all related project status updates. Internal staff coordination based on agency feedback and updates from meetings. Follow up on amendments and notice to proceed. Assistance with meeting notes preparations. Process sub consultant invoices, reimbursable expenses and timesheets for approval.

TSK 2 Geotechnical Studies: Continued email correspondence with CDFW to discuss boring sites and mitigation measures. Review and discuss boring locations and edits to all prepared maps based on discussions. Submit resumes for qualified staff to BLM for approval. Review mitigation measures for geotechnical work and revise based on meetings with BLM and CDFW. Map updates for geotechnical locations. Meeting with BLM to review and edits to POD for geotechnical work and resolved questions/comments on prepared document. Check in with CDFW and email correspondence. Review revegetation plan for geotechnical work.

TSK 3 Technical Studies: Biological Resources - Surveys areas updated in alignment. Updates to biological technical reports based on comments/feedback from BLM and CDFW. Reimbursable Expenses - rental car and lodging for surveys. Cultural Resources - Coordination and check-in meetings with cultural sub consultant for status of survey, necessary permits to perform work, and test pits status. Record Search results from CHRIS and NAHC. Field Work on cultural resources.

TSK 4 Public Outreach: Updates to scoping report per meetings with BLM.

TSK 5 Regulatory Compliance and Permitting: Follow up on submittal of permits for geotechnical work to CDFW, RWQCB, and USACE waivers. Review CDFW LSA Incomplete application letter. Compiling ARD comments for permit packages.

TSK 6 CEQA/NEPA Documentation: Detailed coordination meetings and review of IS/EIR documents based on comments received and input from senior staff QAQC review. Revisions to each section of the documents to provide resource analysis support for project. Updates to maps for environmental document.

Professional Services from January 01, 2024 to January 31, 2024

Phase: TSK1 Initial Coordination (Kick Off Meetings)

Labor

	Hours	Rate	Amount
Principal Engineer	1.00	240.00	240.00
Principal Planner	13.80	198.00	2,732.40

*** Please make checks payable to Provost & Pritchard Consulting Group ***
For billing inquiries, please email Billing@ppeng.com.

Project	04101-23-001	IWVGA CEQA_NEPA Permitting	Invoice	107836
Senior Project Administrator		14.40	122.00	1,756.80
Totals		29.20		4,729.20
Total Labor				4,729.20
Consultants				
Consultants				805.00
Total Consultants				805.00
Reimbursable Expenses				
Postage/Shipping/Delivery				40.48
Total Reimbursables				40.48
			Total this Phase:	\$5,574.68

Phase:	TSK2	Geotechnical Studies		
Labor				
		Hours	Rate	Amount
Associate Biologist		19.70	136.00	2,679.20
Principal Biologist		2.60	180.00	468.00
Totals		22.30		3,147.20
Total Labor				3,147.20
			Total this Phase:	\$3,147.20

Phase:	TSK3	Technical Studies		
Labor				
		Hours	Rate	Amount
Travel Time		5.80	90.00	522.00
Principal Planner		5.00	198.00	990.00
Associate Biologist		25.40	136.00	3,454.40
Senior Project Administrator		1.50	122.00	183.00
Totals		37.70		5,149.40
Total Labor				5,149.40
Reimbursable Expenses				
Travel & Mileage				140.56
Total Reimbursables				140.56
			Total this Phase:	\$5,289.96

Phase:	TSK4	Public Outreach		
Consultants				
Consultants			1,437.50	
Total Consultants			1,437.50	
			Total this Phase:	\$1,437.50

Phase:	TSK5	Regulatory Compliance and Permitting		
Labor				
		Hours	Rate	Amount
Associate Specialist		10.50	127.00	1,333.50
Principal Planner		1.00	198.00	198.00
Associate Biologist		16.90	136.00	2,298.40
Principal Biologist		1.40	180.00	252.00

Project	04101-23-001	IWVGA CEQA_NEPA Permitting	Invoice	107836
Senior Project Administrator		.50	122.00	61.00
Totals		30.30		4,142.90
Total Labor				4,142.90
Reimbursable Expenses				
Postage/Shipping/Delivery				0.00
Total Reimbursables				0.00
			Total this Phase:	\$4,142.90

Phase:	TSK6	CEQA/NEPA Documentation		
Labor				
		Hours	Rate	Amount
Senior Specialist		2.40	157.00	376.80
Project Administrator		5.60	114.00	638.40
Associate Planner		18.60	124.00	2,306.40
Assistant Planner		17.70	103.00	1,823.10
Senior Planner		.30	152.00	45.60
Principal Planner		2.90	198.00	574.20
Associate Biologist		.20	122.00	24.40
Associate Biologist		3.30	136.00	448.80
Totals		51.00		6,237.70
Total Labor				6,237.70
			Total this Phase:	\$6,237.70
			Total this Invoice	<u><u>\$25,829.94</u></u>

The page intentionally blank

PROVOST & PRITCHARD CONSULTING GROUP

455 W Fir Ave • Clovis, CA 93611 • (559) 449-2700
www.provostandpritchard.com

April Keigwin
Indian Wells Valley Groundwater Authority
100 West California Avenue
Ridgecrest, CA 93555

March 07, 2024
Project No: 04101-23-002
Invoice No: 107994

Project Name: IWVGA Imported Water Conveyance Design Services

Client Project #:

See Monthly Progress Report attached to the front of this invoice.

Professional Services from February 01, 2024 to February 29, 2024

Phase: 121P Coordination Meetings

Labor

	Hours	Rate	Amount	
Senior Engineer	3.70	195.00	721.50	
Senior Project Administrator	1.50	115.00	172.50	
Totals	5.20		894.00	
Total Labor				894.00
			Total this Phase:	\$894.00

Phase: 122S Stantec Coordination Meetings

Consultants

Consultants			34.50	
Total Consultants			34.50	34.50
			Total this Phase:	\$34.50

Phase: 132S Stantec General Project Management

Consultants

Consultants			402.50	
Total Consultants			402.50	402.50
			Total this Phase:	\$402.50

Phase: 221P Environmental & ROW Consultant Coordination

Labor

	Hours	Rate	Amount	
Senior Engineer	1.50	195.00	292.50	
Associate Engineer	5.00	133.00	665.00	
Totals	6.50		957.50	
Total Labor				957.50
			Total this Phase:	\$957.50

Phase: 271P BLM Special Use Permit

Labor

	Hours	Rate	Amount	
Senior Engineer	18.20	195.00	3,549.00	

*** Please make checks payable to Provost & Pritchard Consulting Group ***
For billing inquiries, please email Billing@ppeng.com.

Project	04101-23-002	IWVGA Imported Water Conveyance Design	Invoice	107994
Associate Engineer		7.50	133.00	997.50
Associate Specialist		.30	126.00	37.80
Senior Specialist		12.00	165.00	1,980.00
Principal Engineer		6.80	248.00	1,686.40
Associate Biologist		9.20	130.00	1,196.00
Senior Project Administrator		.80	115.00	92.00
Totals		54.80		9,538.70
Total Labor				9,538.70

Total this Phase: \$9,538.70

Phase:	275P	SCE Encroachment Permit (Transmission Line Under Crossing)
Labor		
		Hours Rate Amount
Senior Engineer		4.50 178.00 801.00
Senior Engineer		1.30 195.00 253.50
Associate Technician		2.50 125.00 312.50
Totals		8.30 1,367.00
Total Labor		1,367.00

Total this Phase: \$1,367.00

Phase:	313S	Stantec 30% Submittal
Consultants		
Consultants		26,036.00
Total Consultants		26,036.00
		26,036.00

Total this Phase: \$26,036.00

Phase:	31T6	Electrical System Requirements TM
Labor		
		Hours Rate Amount
Senior Engineer		1.50 171.00 256.50
Totals		1.50 256.50
Total Labor		256.50

Total this Phase: \$256.50

Phase:	31T7	Instrumentation and Controls TM
Consultants		
Consultants		2,277.00
Total Consultants		2,277.00
		2,277.00

Total this Phase: \$2,277.00

Phase:	31T9	Preliminary Permitting Requirements TM 30% Design
Labor		
		Hours Rate Amount
Associate Engineer		5.50 133.00 731.50
Project Administrator		.30 101.00 30.30
Totals		5.80 761.80
Total Labor		761.80

Total this Phase: \$761.80

Phase: 321P P&P 60% Submittal

Labor

	Hours	Rate	Amount	
Senior Engineer	10.00	178.00	1,780.00	
Senior Engineer	2.40	164.00	393.60	
Senior Engineer	3.20	195.00	624.00	
Principal Engineer	1.30	207.00	269.10	
Principal Engineer	1.40	227.00	317.80	
Senior Technician	6.00	150.00	900.00	
Totals	24.30		4,284.50	
Total Labor				4,284.50
			Total this Phase:	\$4,284.50

Phase: 323S Stantec 60% Pumping Facility Design and Specs

Consultants

Consultants			9,326.50	
Total Consultants			9,326.50	9,326.50
			Total this Phase:	\$9,326.50

Phase: 324T 60% Bennett Trenchless Consultants

Consultants

Consultants			1,081.00	
Total Consultants			1,081.00	1,081.00
			Total this Phase:	\$1,081.00

Phase: 421P P&P Water Quality Bench Testing

Labor

	Hours	Rate	Amount	
Senior Engineer	.50	164.00	82.00	
Assistant Engineer	6.90	105.00	724.50	
Totals	7.40		806.50	
Total Labor				806.50
			Total this Phase:	\$806.50

Phase: 422L Water Quality Laboratory Testing

Consultants

Consultants			1,518.00	
Total Consultants			1,518.00	1,518.00
			Total this Phase:	\$1,518.00

Billing Limits

	Current	Prior	To-Date	
Total Billings	59,542.00	2,154,961.16	2,214,503.16	
Budget			3,770,969.00	
Budget Remaining			1,556,465.84	
			Total this Invoice	<u><u>\$59,542.00</u></u>

The page intentionally blank

455 W. Fir Avenue
 Clovis, CA 93611
 (559) 449-2700
 Fax (559) 449-2715



April Keigwin
 Indian Wells Valley Groundwater Authority
 100 West California Avenue
 Ridgecrest, CA 93555

July 12, 2023
 Project No: 04101-23-002
 Invoice No: 101905

Project Name: IWVGA Imported Water Conveyance Design Services

Client Project #:

See Monthly Progress Report for June included in this folder. Attach to front of invoice.

Professional Services from June 1, 2023 to June 30, 2023

Phase: 121P Coordination Meetings

Labor

	Hours	Rate	Amount	
Senior Engineer	20.30	195.00	3,958.50	
Associate Engineer	.50	156.00	78.00	
Principal Engineer	.50	227.00	113.50	
Principal Engineer	3.50	238.00	833.00	
Senior Technician	.30	150.00	45.00	
Totals	25.10		5,028.00	
Total Labor				5,028.00
				Total this Phase: \$5,028.00

Phase: 131P P&P General PM

Labor

	Hours	Rate	Amount	
Senior Engineer	56.10	195.00	10,939.50	
Principal Engineer	3.10	217.00	672.70	
Principal Engineer	.60	227.00	136.20	
Principal Engineer	26.00	238.00	6,188.00	
Project Administrator	.50	94.00	47.00	
Project Administrator	21.30	101.00	2,151.30	
Totals	107.60		20,134.70	
Total Labor				20,134.70

Reimbursable Expenses

Travel & Mileage			86.63	
Total Reimbursables			86.63	86.63
				Total this Phase: \$20,221.33

Phase: 211P Preliminary Design Coordination

Labor

	Hours	Rate	Amount	
Associate GIS Specialist	10.10	105.00	1,060.50	
Totals	10.10		1,060.50	
Total Labor				1,060.50

*** Please make checks payable to Provost & Pritchard Consulting Group ***
 For billing inquiries, please email BillingInquiries@ppeng.com.

Total this Phase: \$1,060.50

Phase: 221P Env & ROW Consultant Coord

Labor

	Hours	Rate	Amount	
Senior Engineer	8.10	195.00	1,579.50	
Totals	8.10		1,579.50	
Total Labor				1,579.50
Total this Phase:				\$1,579.50

Phase: 231P Surveying

Labor

	Hours	Rate	Amount	
Senior Technician	6.00	130.00	780.00	
Licensed Surveyor	42.50	180.00	7,650.00	
Totals	48.50		8,430.00	
Total Labor				8,430.00

Reimbursable Expenses

Travel & Mileage			1,108.40	
Total Reimbursables			1,108.40	1,108.40
Total this Phase:				\$9,538.40

Phase: 241P Utility Research/Coordination

Labor

	Hours	Rate	Amount	
Assistant Engineer	35.80	126.00	4,510.80	
Associate Engineer	1.00	156.00	156.00	
Project Administrator	1.30	94.00	122.20	
Totals	38.10		4,789.00	
Total Labor				4,789.00
Total this Phase:				\$4,789.00

Phase: 251P P&P Coord Geotechnical Services

Labor

	Hours	Rate	Amount	
Senior Engineer	.70	195.00	136.50	
Totals	.70		136.50	
Total Labor				136.50
Total this Phase:				\$136.50

Phase: 252G SEI Geotechnical Services

Consultants

Consultants			70,952.13	
Total Consultants			70,952.13	70,952.13
Total this Phase:				\$70,952.13

Phase: 271P BLM Special Use Permit

Labor

	Hours	Rate	Amount	
Senior Engineer	23.10	195.00	4,504.50	
Assistant Engineer	3.00	126.00	378.00	
Principal Engineer	6.10	238.00	1,451.80	
Senior GIS Specialist	35.80	147.00	5,262.60	
Senior GIS Specialist	.30	175.00	52.50	
Totals	68.30		11,649.40	
Total Labor				11,649.40
		Total this Phase:		\$11,649.40

Phase: 273P City of California City Permit

Labor

	Hours	Rate	Amount	
Senior Engineer	1.20	195.00	234.00	
Principal Engineer	1.00	238.00	238.00	
Totals	2.20		472.00	
Total Labor				472.00
		Total this Phase:		\$472.00

Phase: 274P Kern Roads Agreement/Encroachment Permit

Labor

	Hours	Rate	Amount	
Senior Engineer	9.50	178.00	1,691.00	
Senior Engineer	4.00	195.00	780.00	
Assistant Engineer	9.00	126.00	1,134.00	
Principal Engineer	11.50	207.00	2,380.50	
Totals	34.00		5,985.50	
Total Labor				5,985.50
		Total this Phase:		\$5,985.50

Phase: 275P SCE Encroachment Permit

Labor

	Hours	Rate	Amount	
Principal Engineer	10.70	207.00	2,214.90	
Totals	10.70		2,214.90	
Total Labor				2,214.90
		Total this Phase:		\$2,214.90

Phase: 281P P&P Preliminary Design Report

Labor

	Hours	Rate	Amount
Senior Engineer	32.50	178.00	5,785.00
Senior Engineer	100.40	195.00	19,578.00
Associate Engineer	5.90	140.00	826.00
Assistant Engineer	26.70	112.00	2,990.40
Assistant Engineer	19.10	105.00	2,005.50
Assistant Engineer	15.60	126.00	1,965.60
Associate Engineer	40.50	156.00	6,318.00
Principal Engineer	4.60	217.00	998.20
Principal Engineer	3.50	207.00	724.50

Project	04101-23-002	IWVGA Imported Water Conveyance Design	Invoice	101905
Principal Engineer		36.70	227.00	8,330.90
Principal Engineer		10.80	238.00	2,570.40
Principal Engineer		7.50	248.00	1,860.00
Project Administrator		1.00	94.00	94.00
Assistant Engineer		.50	133.00	66.50
Principal Const. Manager		1.00	215.00	215.00
Totals		306.30		54,328.00
Total Labor				54,328.00
Total this Phase:				\$54,328.00

Phase:	282D	P&P Drafting Preliminary Design		
Labor				
		Hours	Rate	Amount
Senior Engineer		13.00	186.00	2,418.00
Senior Engineer		41.50	178.00	7,387.00
Senior Engineer		30.40	195.00	5,928.00
Associate Engineer		4.40	140.00	616.00
Assistant Engineer		7.00	112.00	784.00
Assistant Engineer		11.60	105.00	1,218.00
Senior Technician		17.80	143.00	2,545.40
Assistant Engineer		93.10	126.00	11,730.60
Associate Engineer		10.00	156.00	1,560.00
Principal Engineer		.50	217.00	108.50
Principal Engineer		8.00	207.00	1,656.00
Principal Engineer		3.50	227.00	794.50
Principal Engineer		1.00	248.00	248.00
Project Administrator		.40	88.00	35.20
Senior Technician		27.70	158.00	4,376.60
Senior Technician		86.60	150.00	12,990.00
Senior GIS Specialist		11.30	147.00	1,661.10
Associate Technician		74.60	119.00	8,877.40
Associate GIS Specialist		.40	105.00	42.00
Totals		442.80		64,976.30
Total Labor				64,976.30
Total this Phase:				\$64,976.30

Phase:	286Q	Dahl Preliminary Design Report		
Consultants				
Consultants				1,104.00
Total Consultants				1,104.00
Total this Phase:				\$1,104.00

Phase:	28T1	Preliminary System Hydraulics TM Stantec		
Labor				
		Hours	Rate	Amount
Principal Engineer		1.00	238.00	238.00
Totals		1.00		238.00
Total Labor				238.00
Total this Phase:				\$238.00

Phase: 28T2 Pipe Optimizations TM

Labor

	Hours	Rate	Amount	
Principal Engineer	3.70	217.00	802.90	
Principal Engineer	1.50	238.00	357.00	
Totals	5.20		1,159.90	
Total Labor				1,159.90
		Total this Phase:		\$1,159.90

Billing Limits

	Current	Prior	To-Date	
Total Billings	255,433.36	653,491.18	908,924.54	
Budget			3,770,969.00	
Budget Remaining			2,862,044.46	
		Total this Invoice		<u><u>\$255,433.36</u></u>

The page intentionally blank

April Keigwin
 Indian Wells Valley Groundwater Authority
 100 West California Avenue
 Ridgecrest, CA 93555

July 13, 2023
 Project No: 04101-23-001
 Invoice No: 102004

Project Name: Indian Wells Valley Groundwater Authority-CEQA/NEPA Documents and Permit Documentation

Client Project #:

TSK 1 Initial Coordination: Initial Coordination tasks with staff and agencies to keep project schedule on track. Weekly coordination meetings and tasks for project progression and MOU. Process contract amendment for sub consultant and project reallocated tasks. Update budget tracker spreadsheet with latest received information. Email correspondence.

TSK 2 Geotechnical Studies: Email correspondence regarding scheduling of geotechnical monitoring work. Draft SF-299 language and send to subconsultant. Updates from BLM on CatEx document review and next steps in process. Review and process draft invoice for phase tasks. WEAP presentation by biological field staff for Geotech construction work. Reimbursable expenses – travel time to California City for field surveys and site construction monitoring on geotechnical investigation work, rental car expense and gas, mileage for additional company vehicle, meals.

TSK 3 Technical Studies: Biological - Preparation and research for additional technical reports and agency coordination. Biological staff coordination for surveys and fieldwork. Prepare, draft, review and revisions for Wildlife Report and Mitigation Memo. Discussion and coordination with CDFW and USFWS for surveys and avoidance measures. Collect biological field data, import and export data for staff. Prepare Geotech maps for biological field surveys. Cultural - Meeting with cultural sub about extended buffer for survey. Scope amendment discussion with subs. Coordination and discussion with BLM regarding project description for cultural work. Prepare spreadsheet of APNs for bio and cultural surveys, included and excluded. Air Quality/Greenhouse Gas/Noise – Email correspondence with sub consultant on needs and status of reports for project.

TSK 4 Public Outreach: Coordination meeting with Stantec to discuss details and timelines for Scoping Meeting in California City and Ridgecrest. Add items to agenda for Stetson and Authority to approve for Scoping Meetings, including list of information needed for meeting execution. Stantec subconsultant tasks for scoping meeting preparation. Email correspondence.

TSK 5 Regulatory Compliance and Permitting: Meeting with BLM to discuss permitting needs. Questions and coordination regarding Aquatic Resources Delineation. Email correspondence between staff, BLM, and subconsultant. Process subconsultant invoices for phase tasks.

TSK 6 CEQA/NEPA Documentation: Weekly check-in meeting for CEQA & NEPA tasks and coordination. Continue research and continue drafting Project Description and Alternatives analysis needed for environmental documentation. Drafting sections for CEQA and NEPA reports. Drafting and revising exhibits for reports. Email correspondence and coordination amongst staff.

Professional Services from June 1, 2023 to June 30, 2023

Phase:	TSK1	Initial Coordination		
Labor				
			Hours	Rate
				Amount
	Principal Engineer		2.80	217.00
	Project Administrator		12.60	108.00
	Principal Planner		18.50	188.00
	Associate Biologist		.50	130.00
	Totals		34.40	5,511.40
	Total Labor			5,511.40
Consultants				
	Consultants			2,062.81
	Total Consultants			2,062.81
			Total this Phase:	\$7,574.21

*** Please make checks payable to Provost & Pritchard Consulting Group ***
 For billing inquiries, please email BillingInquiries@ppeng.com.

Phase: TSK2 Geotechnical Studies

Labor

	Hours	Rate	Amount	
Project Administrator	1.80	108.00	194.40	
Assistant Envir. Spec.	.30	120.00	36.00	
Principal Planner	7.90	188.00	1,485.20	
Associate Biologist	4.20	116.00	487.20	
Associate Biologist	37.30	130.00	4,849.00	
Assistant Biologist	9.20	100.00	920.00	
Principal Biologist	2.40	165.00	396.00	
Travel Time	11.00	80.00	880.00	
Totals	74.10		9,247.80	
Total Labor				9,247.80

Consultants

Consultants			1,725.00	
Total Consultants			1,725.00	1,725.00

Reimbursable Expenses

Travel & Mileage			1,101.78	
Other Direct Reimb Expenses			122.92	
Total Reimbursables			1,224.70	1,224.70

Total this Phase: \$12,197.50

Phase: TSK3 Technical Studies

Labor

	Hours	Rate	Amount	
Assistant Engineer	5.00	126.00	630.00	
Project Administrator	.30	94.00	28.20	
Project Administrator	8.70	108.00	939.60	
Senior GIS Specialist	45.30	147.00	6,659.10	
Principal Planner	15.60	188.00	2,932.80	
Associate GIS Specialist	2.20	105.00	231.00	
Associate Biologist	45.60	116.00	5,289.60	
Associate Biologist	82.70	130.00	10,751.00	
Principal Biologist	28.60	165.00	4,719.00	
Totals	234.00		32,180.30	
Total Labor				32,180.30

Consultants

Consultants			7,693.87	
Total Consultants			7,693.87	7,693.87

Reimbursable Expenses

Travel & Mileage			1,537.31	
Total Reimbursables			1,537.31	1,537.31

Total this Phase: \$41,411.48

Phase: TSK4 Public Outreach

Labor

	Hours	Rate	Amount	
Project Administrator	1.70	108.00	183.60	
Principal Planner	4.70	188.00	883.60	

Project	04101-23-001	CEQA/NEPA Documents and Permit Documenta	Invoice	102004
Senior Planner		3.00	173.00	519.00
Totals		9.40		1,586.20
Total Labor				1,586.20
Consultants				
Consultants				1,196.00
Total Consultants				1,196.00
			Total this Phase:	\$2,782.20

Phase:	TSK5	Regulatory Compliance and Permitting		
Labor				
		Hours	Rate	Amount
Project Administrator		.50	108.00	54.00
Principal Planner		7.60	188.00	1,428.80
Totals		8.10		1,482.80
Total Labor				1,482.80
Consultants				
Consultants				49,338.09
Total Consultants				49,338.09
			Total this Phase:	\$50,820.89

Phase:	TSK6	CEQA/NEPA Documentation		
Labor				
		Hours	Rate	Amount
Project Administrator		.60	94.00	56.40
Project Administrator		2.30	108.00	248.40
Assistant Planner		37.40	110.00	4,114.00
Assistant Planner		20.00	90.00	1,800.00
Principal Planner		21.20	188.00	3,985.60
Associate Planner		1.80	138.00	248.40
Associate GIS Specialist		1.20	105.00	126.00
Associate GIS Specialist		2.80	125.00	350.00
Assistant Biologist		4.00	100.00	400.00
Totals		91.30		11,328.80
Total Labor				11,328.80
			Total this Phase:	\$11,328.80
			Total this Invoice	<u><u>\$126,115.08</u></u>

The page intentionally blank



Invoice

Please remit payment to:
P.O. Box 71368
Chicago, IL 60694-1368

TranSystems Corporation

www.transystems.com

If you have any questions, please call:
(562) 304-2000

Client:

Indian Wells Valley Groundwater Authorit
Attn: April Keigwin - Clerk of the Board
100 W California Ave.
Ridgecrest, CA 93555

Reference:

Invoice Date: 2/29/2024
Project No: P601230025
Invoice No: INV-0004412328

Project Name: IWV-Imported Water Pipeline

For professional services rendered through February 29, 2024 for the above referenced project.

Staff Type	Name	Rate	Hours	Amount
Labor				
Project Consultant 3	Donald M. Anderson	150.00	1.00	\$150.00
Total Labor			1.00	\$150.00
Invoice Total				\$150.00

TranSystems Corporation

Donald M. Anderson, **SRWA**
Senior Project Manager

TERMS: PAYABLE UPON RECEIPT

1 1/2% INTEREST CHARGE PER MONTH WILL BE ADDED TO ALL PAST DUE INVOICES OLDER THAN 45 DAYS IF INDICATED IN THE CONTRACT TERMS

Hours Charged by Project

For Timesheet Period: 2/1/2024 - 2/29/2024

Project	Name	Time By Day	Entered Hours	Daily Comments
P601230025				
	Donald M. Anderson			
		2/5/2024	0.80	Bi-Weekly PDT meeting.
		2/7/2024	0.20	Reviewed Jan 24 invoice.
P601230025			1.00	
Grand Total			1.00	

The page intentionally blank

WellIntel Inc.

906 E. Hamilton St.
Milwaukee, WI 53202 US
844-935-5426
accounting@wellintel.com



INVOICE

BILL TO
April Keigwin
Indian Wells Valley Groundwater Authority
500 W. Ridgecrest Blvd.
Ridgecrest, CA 93555 USA

SHIP TO
April Keigwin
Indian Wells Valley Groundwater Authority
500 W RIDGECREST BLVD
RIDGECREST, CA 93555-4017 US

INVOICE 2889
DATE 02/27/2024
TERMS Net 30
DUE DATE 03/28/2024

P.O. NUMBER
2024 WellIntel Data Service

EMAIL
akeigwin@rgs.ca.gov

ITEM	DESCRIPTION	QTY	RATE	AMOUNT
2DSNN12 - Annual	Analytics Dashboard Data Services (annual) BC's Well MS's Well GH's Well GC's Well SZ's Well CH's	6	240.00	1,440.00T
Sales Tax	Sales Tax calculated by AvaTax on Wed 28 Feb 01:11:53 UTC 2024	1	133.20	133.20

SUBTOTAL	1,573.20
TAX (0)	0.00
TOTAL	1,573.20
BALANCE DUE	\$1,573.20

The page intentionally blank



January 2024

Dear Affiliate Member:

Thank you for your **Affiliate Membership with the California Association for Mutual Water Companies (CalMutuals), and your participation in CalMutuals JPRIMA insurance program.** As a reminder, membership with CalMutuals is required to enjoy JPRIMA insurance coverage. Membership is free to CalMutuals JPRIMA insureds for the first year and offered at a reduced rate thereafter.

Enclosed is an invoice for your 2024 membership dues which is discounted as a result of your participation in the CalMutuals JPRIMA insurance program. Also enclosed is a contact form with information for your organization. We kindly ask you to review and update your information to help us more effectively serve you. Membership dues and contact information can be updated through US Mail or online at <https://caomwc.wildapricot.org/>

In 2023, CalMutuals JPRIMA retained existing members and further expanded membership. CalMutuals JPRIMA has maintained competitive pricing and again declared a dividend for all Workers' Comp clients insured in policy year 2020 equaling 5% of the 2020 annual premium paid. This year CalMutuals JPRIMA has expanded insurance offerings beyond Property and Casualty, Workers' Compensation and Pollution to include a new Cybersecurity insurance product.

CalMutuals JPRIMA continues to invest insurance residuals to generate needed funding for resources that help CalMutuals' small system members. These resources are available to our Affiliate members as well. Resources are available at no cost to member water systems with less than 500 service connections and to members purchasing *both* the JPRIMA P&C and Workers' Comp insurance. For all remaining members, resources are offered at a reduced cost. These resources include:

- **Online Water Treatment and Distribution Operator training courses and Continuing Education Units (CEUs)** for members' board and staff through the *American Water College*.
- **Background checks** for potential employees, employees, and potential board members to assure the quality of leaders, employees and potential candidates through *OPEN Online*.
- **Management Training Video series** in conjunction with *American Association of Water Distribution & Management*. The subjects of the videos include Inverse Condemnation, Critical Infrastructure, Climate Change and Risk Management and include perspectives from attorneys, insurance professionals, and case studies presented by water agency managers.

We value your membership and look forward to continued collaboration in 2024. If you or another member of your organization have questions about CalMutuals or CalMutuals JPRIMA, please do not hesitate to contact us.
Sincerely,

Karina Cervantez
Managing Director
California Association of Mutual Water Companies

Susan Allen
Chief Executive Officer
California Association of Mutual Water Companies
Joint Powers Risk and Insurance Management Authority



MEMBER CONTACT INFORMATION

Please review and update contact information associated with your CalMutuals membership.

To update online: Log in to <https://caomwc.wildapricot.org/> To update by mail: Review and revise this form and return with your membership dues. Many thanks!

Company	Indian Creek-Westridge Community Services District	
Website		
Mailing Address	P.O.Box 952 Bishop, CA 93514	
Physical Address (if different)		
County	Inyo	
Manager Contact		<input type="checkbox"/> Manager is Primary Contact
Manager-First	Terry	
Manager-Last	Tye	
Title	General Manager	
Manager Email		
Manager Telephone	760-920-1472	
Manager Cell		
Board Contact		<input type="checkbox"/> Board is Primary Contact
Board First	Terry	
Board Last	Tye	
Board Title	President	
Board Email		
Board Telephone		
Staff Contact		<input type="checkbox"/> Staff is Primary Contact
Staff-First		
Staff-Last		
Staff-Title		
Staff EMail		
Staff Telephone		
Annual Revenue	\$ \$100,000	
Company Type	<input type="checkbox"/> Drinking Water <input type="checkbox"/> Irrigation <input type="checkbox"/> Other	
# of Connections or # Acres Served		
Please identify the three most critical issues/concerns facing your Company in 2022:		



Your insurance partner beyond the policy

Your Property and Casualty Insurance is provided by CalMutuals JPRIMA. CalMutuals JPRIMA is a joint powers authority formed in 2016 through the passage of AB 656 with the purpose of providing best in class insurance to its members and ensuring technical and managerial resources to small water systems. CalMutuals JPRIMA proudly serves just under 400 water systems from the smallest to the largest, throughout California.

Insurance with CalMutuals JPRIMA requires membership with CalMutuals. Insureds that are not mutual water companies participate in the Association as *Affiliate Members*. CalMutuals JPRIMA takes pride in being your "insurance partner beyond the policy".

Benefits of CalMutuals membership include:



Assistance to Very Small Systems

Affiliate Member dues help CalMutuals JPRIMA in providing sorely needed risk reduction support to very small (15-2999 connections) and disadvantaged water systems. CalMutuals JPRIMA further invests insurance residuals to programs and services to address critical needs of small water systems.



* Continuing Education

Help your team meet continuing education requirements. Enroll in free operator, safety, and management online training modules; including state-mandated board member ethics training.



* Employee Background Checks

Streamline your hiring processes by taking advantage of free or discounted background checks by OPENonline for criminal records, identity, driver's records, education and more.



Peer-to-Peer Support

Connect with CalMutuals members to address shared challenges. As issues emerge, reach out and we will work to identify members who may be able to provide insight, assistance and guidance.



Leadership Video Series

Tap into a vast and virtual library of videos on cybersecurity, inverse condemnation, risk management, human resources fundamentals and more, courtesy of our partnership with the American Association of Water Distribution & Management (AAWD&M).



Referrals to Preferred Vendors

Link to CalMutuals' preferred vendors; with expertise ranging from website design to pipe, valve and meter supply, to financial and engineering services. They're experienced in working with small systems and often provide discounts for members.



* Public Relations Support

Get free help with an immediate communications challenge from our partner Ortega Strategies Group. Ongoing public relations assistance is available to members on a consulting basis at a discounted rate.



Risk Management and Human Resources Tools

Members with Workers' Compensation insurance get answers to human resources and safety professionals questions using The Zenith's toll-free number. Find thousands of risk management, safety, and HR best practices resources at your fingertips through the Zenith Solution Center.

REGISTER OR LEARN MORE

www.calmutuals.org/resources
www.calmutualsjprima.org/resources

info@calmutuals.org • (714) 709-4040

* Free to members with <500 connections and members with property and liability and worker's compensation insurance through JPRIMA. Discounted for all others.

California Association of Mutual Water Companies
 583 E Sacramento Street
 Altadena, CA 91001



INVOICE

BILL TO	Date	Invoice No
Indian Wells Valley Groundwater Authority Ron Strand General Manager 500 W Ridgecrest Blvd. Ridgecrest, CA 93555	Jan 18, 2024	02918

Description	Rate	Due Date
		Total
CalMutuals 2024 Membership Dues AFFILIATE MEMBERS:Non-Portable Districts		\$100
Please make checks payable to California Association of Mutual Water Companies and send payments to the address at the top of the invoice. Payments accepted online by credit card at https://caomwc.wildapricot.org/ . For billing inquiries, please call (714) 709-4040. Thank you!	Total	\$100
	Payments	
	Balance Due	\$100

The page intentionally blank

IWVGA ADMINISTRATIVE OFFICE

STAFF REPORT

TO: IWVGA Board Members **DATE:** March 29, 2024
FROM: IWVGA Staff
SUBJECT: Agenda Item 9 – Receive and File Water Year 2023 Annual Report

BACKGROUND AND DISCUSSION

The Indian Wells Valley Groundwater Authority (IWVGA) has prepared the Water Year (WY) 2023 Annual Report for the Indian Wells Valley Groundwater Basin (IWVGB), Basin 6-054, to be submitted to the California Department of Water Resources (DWR) in compliance with the Sustainable Groundwater Management Act (SGMA). The Annual Report presents required data for WY 2023 (October 1, 2022-September 30, 2023) and includes an update on Basin conditions and Basin projects and management activities. The Draft WY 2023 Annual Report was provided for review on January 5, 2024. Comments that were received from Mojave Pistachios, LLC and Searles Valley Minerals Inc. were reviewed and considered for incorporation. No substantial revisions were required or have been made to the original January Draft Report. The WY 2023 Annual Report has been finalized and is required to be submitted to DWR by April 1, 2024.

ACTION(S) REQUIRED BY THE BOARD

Staff recommends the Board receive and file WY 2023 Annual Report.

The page intentionally blank

INDIAN WELLS VALLEY GROUNDWATER BASIN

FINAL DRAFT

GSP Annual Report

Water Year 2023

(October 1, 2022 to September 30, 2023)

March 2024

Page Intentionally Left Blank

Contents

Chapter 1 Executive Summary	1
Chapter 2 General Information.....	5
Chapter 3 Progress Towards GSP Implementation and Sustainability	7
3.1 Projects and Management Actions.....	7
3.1.1 Management Action 1: Annual Pumping Allocation Plan, Transient Pool, and Fallowing Program 8	
3.1.2 Project 1: Develop Imported Water Supply.....	8
3.1.3 Project 2: Optimize Recycled Water	11
3.1.4 Project 3: Conservation Efforts.....	12
3.1.5 Project 4: Shallow Well Mitigation Program.....	13
3.1.6 Project 5: Dust Control Mitigation Program	14
3.1.7 Project 6: Pumping Optimization Project	14
3.2 Progress Towards Sustainable Management Criteria.....	14
3.2.1 Chronic Lowering of Groundwater Levels.....	15
3.2.2 Reduction of Groundwater in Storage.....	17
3.2.3 Degraded Water Quality	17
3.2.4 Land Subsidence Related to Groundwater Pumping.....	19
3.3 Progress Made on Addressing Recommended Corrective Actions	19
3.4 Outreach and Engagement	21
Chapter 4 Hydrologic Conditions	23
Chapter 5 Groundwater Elevation Data.....	25
5.1 Groundwater Elevation Contour Maps.....	26
5.2 Hydrographs.....	26
5.3 Estimated Change in Groundwater Storage	29

5.3.1	Groundwater Level Change from Spring 2022 to Spring 2023	29
5.3.2	Estimating Storage Change Using Modified Thiessen Polygon Method	30
Chapter 6 Water Supply Data		35
6.1	Groundwater Extraction Data	35
6.2	Surface Water Supply	38
6.3	Total Water Use	39
Chapter 7 Other Data Collection and Basin Management Tasks		41
7.1	Annual Groundwater Quality Sampling	41
7.1.1	TDS Results	41
7.1.2	Arsenic Results	43
7.2	Los Angeles Department of Water and Power Water Releases	44
7.3	Rose Valley Subsurface Flow Monitoring and Evaluation	44
7.4	El Paso Monitoring and Evaluation	45
7.5	Brackish Water Investigation	45
7.6	Numerical Model	45
7.7	Data Management System	46
7.8	Precipitation Station and Stream Gage Data Collection	47
7.9	Groundwater Dependent Ecosystems	47
Chapter 8 References		49

List of Tables

Table 3-1: Representative Monitoring Sites for Chronic Lowering of Groundwater Levels	16
Table 3-2: Representative Monitoring Sites for Degraded Water Quality	18
Table 3-3: Recommended Corrective Actions Summary	20
Table 4-1: Percent Exceedance Ranges and Dividing Thresholds for Five Water Year Types	24
Table 4-2: Water Year Types based on Precipitation at China Lake NAF Station (No. 041733)	24
Table 5-1: Estimated Annual Change to Groundwater in Storage, Spring 2022 to Spring 2023	32
Table 5-2: WY 2020 to WY 2023 Estimated Groundwater Storage Change, Modified Thiessen Polygon Method	33
Table 6-1: IWVGB Groundwater Production Estimates	37
Table 6-2: Total Estimated Pumping by Water Year	38
Table 6-3: WY 2023 Recycled Water Use	38
Table 6-4: WY 2023 Estimated Total Water Use in the IWVGB	39

List of Figures

Figure 2-1	Indian Wells Valley Groundwater Basin and Indian Wells Valley Groundwater Authority Boundaries
Figure 3-1	Chronic lowering of Groundwater Levels Representative Monitoring Sites
Figure 3-2	Water Quality Degradation Representative Monitoring Sites
Figure 4-1	Annual Precipitation Exceedance in IWVGB at Index Station China Lake NAF
Figure 5-1	Estimated Fall 2022 Groundwater Elevation Contours
Figure 5-2	Estimated Spring 2023 Groundwater Elevation Contours
Figure 5-3	Estimated Fall 2022 Groundwater Depth Contours
Figure 5-4	Estimated Spring 2023 Groundwater Depth Contours
Figure 5-5	Monitoring Wells with Hydrographs in Attachment E
Figure 5-6	Annual Groundwater Level Change WY 2023
Figure 5-7	Modified Thiessen Polygon Method Estimating Changes to Groundwater in Storage
Figure 5-8	Estimated Groundwater Storage Change WY 2016-2023
Figure 6-1	Pumping Well Location Map
Figure 7-1	Groundwater Quality – TDS, Fall 2022

Figure 7-2 Historical TDS Concentrations

Figure 7-3 Groundwater Quality – Arsenic, Fall 2022

List of Attachments

Attachment A DWR Annual Report Submittal Tables

Attachment B Historical Water Year Types Based on Precipitation at China Lake NAF (No. 041733)

Attachment C Groundwater Monitoring Program Updates

Attachment D WY 2023 Groundwater Level Data

Attachment E Hydrographs for Select Monitoring Wells

Attachment F Storage Change Estimate Using Thiessen Polygon Method

Attachment G Estimated WY 2023 Groundwater Production

Attachment H WY 2023 Water Quality Data

Attachment I IWV Model Configuration Item List

Attachment J WY 2022 Precipitation and Stream Gage Data

Chapter 1 Executive Summary

The Indian Wells Valley Groundwater Authority (IWVGA) has prepared this Annual Report for the Indian Wells Valley Groundwater Basin (IWVGB or Basin), Basin 6-054, to be submitted to the California Department of Water Resources (DWR) in compliance with the Sustainable Groundwater Management Act (SGMA). This Annual Report presents required data for Water Year (WY) 2023 (October 1, 2022-September 30, 2023).

DWR has designated the IWVGB as a basin in critical overdraft. Overdraft in the IWVGB has been shown through several undesirable results, primarily the chronic lowering of groundwater levels, the degradation of water quality, and the reduction of groundwater in storage in the IWVGB. Consequently, under SGMA, the IWVGA must implement projects and management actions to mitigate and avoid undesirable results and reach sustainability by 2040. The sustainability goal is to manage and preserve the IWVGB groundwater resource as a sustainable water supply. To the greatest extent possible, the goal is to preserve the character of the community, preserve the quality of life of IWV residents, and sustain the mission at the U.S. Navy Naval Air Weapon Station (NAWS) China Lake.

The Groundwater Sustainability Plan (GSP) for the IWVGB (Stetson, 2020a) was adopted by the IWVGA Board of Directors on January 16, 2020 and submitted to DWR on January 31, 2020. DWR approved the IWV GSP in January 2022. The sustainable yield is estimated to be 7,650 acre-feet per year (AFY) based on measured groundwater levels and computer modeling, and the recommendation of the IWVGA Technical Advisory Committee (TAC). The GSP recommended projects and management actions to achieve Basin sustainability that are intended to culminate in managing the IWVGB within the sustainable yield without undesirable and unsustainable groundwater conditions in the IWVGB. Sustainable management criteria were established for determining undesirable results and measuring progress towards groundwater sustainability.

During WY 2023, no minimum thresholds were exceeded at the representative monitoring sites. The IWVGA continued developing and implementing projects and management actions proposed in the GSP and tracking sustainability using the sustainable management criteria. Significant achievements include the following:

- Improvements in collecting observation data

- Completion of the Imported Water Pipeline Alignment Study
- Initiation of Design of the Imported Water Interconnection Project
- Implementation of the Shallow Well Mitigation Program
- Revisions to the groundwater flow model that will incorporate new data that has been obtained
- Incorporation of Recommended Corrective Actions

These projects and management actions will ultimately reduce overdraft conditions in the Basin and reduce undesirable results.

During WY 2023, litigation continued along with adjudication actions. As a result, the current litigation has brought into question the accuracy of some self-reported groundwater production data due to inconsistencies with reported groundwater production and documented and stated water use.

During WY 2023, the Indian Wells Valley received approximately 8.27 inches of rain, classifying the year as a Wet year. In WY 2023, depth to groundwater (DTW) was measured at 147 wells in Fall 2022 and 151 wells in Spring 2023, a greater total number of data points than collected in WY 2022. Hydrographs have been developed for all wells in the monitoring program and are posted on the Data Management System (DMS) website (www.iwvgs.com). Groundwater levels have historically declined in many parts of the IWVGB and continued during the period from Spring 2022 through Spring 2023.

Groundwater production during WY 2023 is estimated to be 19,150 AF and recycled water use is estimated to be 1,300 AF. Accordingly, total water use in the IWVGB in WY 2023 is estimated to be 20,450 AF.

This Annual Report provides an update on Basin conditions and Basin management activities organized into the following chapters:

- General information (including Basin location)
- Progress towards GSP implementation and sustainability
- Hydrologic conditions
- Groundwater elevation data (including contours and hydrographs)
- Groundwater storage data
- Water supply data (including groundwater extraction data)
- Other Data Collection and Basin Management Tasks

The IWVGA was made aware of a new DWR guidance document pertaining to Annual Reports, Periodic Evaluations, and Plan Amendments on October 30, 2023 (DWR, 2023a). After review of the guidance document, IWVGA Staff found that the current IWVGA GSP Annual Report format substantially and functionally complied with DWR’s new guidance, due to being based on the Annual Report requirements provided in the GSP regulations (CCR, Title 23, Division 2. Chapter 1.5. Sections 351 and 356.2). Since the current IWVGA GSP Annual Report format substantially complies with DWR’s new guidance, and also considering the short timeline before a draft Annual Report would be released to the public, it was decided that a reformat of the Annual Report was not necessary. However, in order to fully address the recommendations provided in the guidance document, two new subsections were added to this Annual Report: “Progress Made on Addressing Recommended Corrective Actions” and “Outreach and Engagement”. DWR’s Annual Report submittal spreadsheets are provided in Attachment A.

Page Intentionally Left Blank

Chapter 2 General Information

The IWVGB is located in the northwestern part of the Mojave Desert and underlies approximately 382,000 acres or approximately 600 square miles of land area in portions of the Counties of Kern, Inyo, and San Bernardino. The IWVGB is bordered on the west by the Sierra Nevada Mountain Range, on the north by the Coso Range, on the east by the Argus Range, and on the south by the El Paso Mountains. Intermittent surface water (following larger storm events) flows from the surrounding mountain ranges and drains to China Lake, a large normally dry lake, or playa, located in the central north-east part of the Basin.

The land overlying the IWVGB encompasses portions of Kern, Inyo, and San Bernardino Counties, with the majority (approximately 73%) being in Kern County. Approximately 79% of land overlying the IWVGB comprises of either the NAWS China Lake or public lands managed by the United States Bureau of Land Management (BLM). The City of Ridgecrest (Ridgecrest or City) is the only incorporated community in the Indian Wells Valley and covers an area of approximately 20 square miles with a population of approximately 29,000 people. The Indian Wells Valley Water District (IWWVD) serves potable water to approximately 35,800 people in Ridgecrest and certain areas outside of Ridgecrest's jurisdiction. Unincorporated communities in the Indian Wells Valley include the communities of Inyokern in Kern County and Pearsonville in Inyo County, along with other smaller communities. Additionally, there are communities outside of the Indian Wells Valley that are served by groundwater produced in the Basin, including Trona.

Kern County, Inyo County, San Bernardino County, Ridgecrest, and the IWWVD entered into a joint exercise of powers agreement to form the IWVGA and serve as General Members on the IWVGA Board of Directors, which governs the IWVGA as a whole. The U.S. Navy and BLM serve as Associate Members (non-voting) on the IWVGA Board of Directors. Figure 2-1 provides the location of the IWVGB and the extents of the IWVGA boundaries.

In its 2016 Bulletin 118 interim update, DWR identified the IWVGB as a critically overdrafted basin of medium priority¹. As such, in compliance with SGMA, the associated groundwater sustainability agency (GSA) was required to submit a GSP by January 31, 2020 to achieve local sustainable management of groundwater resources. The IWVGA Board of Directors adopted Resolution No. 02-16 on December 8,

¹ The IWVGB has since been identified as a critically overdrafted basin of **high** priority as of the *Sustainable Groundwater Management Act 2018 Basin Prioritization: Process and Results*, published by DWR in January 2019.

2016, to establish the IWVGA as the exclusive GSA for the entirety of the IWVGB. The GSP for the IWVGB (Stetson, 2020a) was adopted by the IWVGA Board of Directors on January 16, 2020 and was submitted to DWR on January 31, 2020. DWR approved the IWV GSP on January 13, 2022 and provided recommended corrective actions that are strongly recommended to be addressed prior to the first Periodic Evaluation due to DWR in January 2025.

The IWVGB serves as the sole supply of potable water for the Indian Wells Valley. Residents of the Indian Wells Valley are served groundwater through private domestic wells, small cooperative groups sharing wells, small mutual water companies, the Inyokern Community Services District (Inyokern CSD), and the IWVWD. The U.S. Navy produces and distributes groundwater for on-station water uses at the NAWS China Lake. Searles Valley Minerals Inc. produces groundwater from the IWVGB for use in its minerals recovery and processing operations in Searles Valley (located east of the IWVGB) and for potable use in the small communities of Trona, Westend, Argus, and Pioneer Point in the Searles Valley. In addition, a number of farms located in the Indian Wells Valley rely on the IWVGB's water supplies for their agricultural operations. Overdraft conditions in the IWVGB have existed since at least the 1960s (Dutcher and Moyle, 1973). Results of overdraft have manifested themselves through various undesirable results, primarily the chronic lowering of groundwater levels, degradation of water quality, and reduction of groundwater storage within the IWVGB.

Chapter 3 Progress Towards GSP Implementation and Sustainability

The IWVGB is characterized as a critically overdraft basin by DWR. The sustainable yield is estimated to be 7,650 AFY, while groundwater production has been and continues to be greater than the sustainable yield. This condition accounts for the occurrence of undesirable results for the following sustainability indicators:

- Chronic lowering of groundwater levels
- Reduction of groundwater in storage
- Degraded water quality
- Potential for land subsidence

After extensive public outreach and collaboration, the IWVGA Board of Directors adopted the IWVG GSP on January 16, 2020. In compliance with SGMA, the GSP provides Basin management strategies that are intended to culminate in managing the IWVGB within the sustainable yield and the absence of undesirable and unsustainable groundwater conditions in the IWVGB. The GSP recommends projects and management actions that are intended to achieve Basin sustainability while considering the unique geologic and hydrogeologic conditions of the IWVGB. Sustainable management criteria were established for measuring progress towards groundwater sustainability. Recommendations of the GSP are intended to provide for long-term sustainable groundwater management in the IWVGB within 20 years (WY 2040) of GSP implementation.

During WY 2023, the IWVGA continued developing projects and management actions proposed in the GSP and continued tracking sustainability using the proposed sustainable management criteria, discussed further in the subsections below. Significant progress was made toward implementing the Imported Water Project, implementing the Shallow Well Mitigation Program, and addressing DWR's Recommended Corrective Actions (RCAs) on the IWVGA GSP. In addition, the IWVGA continued significant data collection efforts to fill data gaps. These data collection efforts are documented in Chapter 7.

3.1 Projects and Management Actions

The following subsections document progress made towards implementation of projects and management actions proposed in the GSP. Additional information regarding projects and management actions can be found in the GSP.

3.1.1 Management Action 1: Annual Pumping Allocation Plan, Transient Pool, and Following Program

During WY 2023, the IWVGA continued to implement Management Action 1 with the intent to fund an imported water supply and to provide economic incentives to reduce groundwater pumping.

On July 16, 2020, the IWVGA Board of Directors adopted Resolution Number 06-20 to adopt a report documenting the estimated sustainable yield of the IWVGB as 7,650 AFY. The purpose of determining the sustainable yield allotment is to determine the estimated volume of the sustainable yield available for the pumpers to produce without incurring Replenishment Fees in calendar year 2023. IWVWD continued to pay replenishment fees in WY 2023 based on the initial allotments presented in the 2020 report on the estimated sustainable yield of the Basin. Other producers subject to the replenishment fee, Mojave Pistachios and Searles Valley Minerals, did not pay the replenishment fee in WY 2023 and continue to not pay the fee. The nonpayment of fees by these major groundwater producers is one subject of current litigation. This litigation has impeded the implementation of the GSP and has called into the question of the accuracy of some self-reported groundwater production data.

The IWVGA has developed a Transient Pool Program to facilitate transitional reduced agricultural pumping to an interim acceptable and manageable level of basin overdraft until augmented supplies are available. In WY 2023, Transient Pool members produced groundwater within their allocations. One Transient Pool producer sold its ranch and transferred its full Transient Pool allocation to the new property owners.

Currently, there is no funding for the Following Program, so it is not available at this time. The IWVGA is pursuing grant funding opportunities to fund following projects.

3.1.2 Project 1: Develop Imported Water Supply

Due to overdraft conditions in the Indian Wells Valley and anticipated future water demands significantly in excess of the Basin sustainable yield, securing imported water supplies is a priority for the Basin. Conservation measures alone cannot bring the Basin into sustainability. The IWVGA has retained Capitol Core Group, Inc (Capitol Core) for the following general tasks:

- Identify and Procure Imported Water Supplies
- Develop and Secure Transfer Partners
- Identify and Secure Funding Sources

During WY 2022, Capitol Core identified potential permanent water supplies and actively pursued transfer deals with those water supply holders. In August 2022, the IWVGA executed a letter of intent between the IWVGA and a seller of water rights in the Dudley Ridge Water District. Proposals to finance the purchase of the water rights were received by the IWVGA in September 2022. In WY 2023, work continued on the permitting and transfer discussions with the relevant districts and regulatory authorities; however, ultimately, the transfer terms were not agreed upon. Capitol Core is continuously pursuing permanent water supplies and is in discussion with other entities for the sale and transfer of water rights.

Capitol Core continued discussions with Antelope Valley East Kern Water Agency (AVEK) concerning transfer agreements associated with the interconnection pipeline. The IWVGA is considering the option of joining AVEK with annexation into the AVEK service area.

In WY 2022, the IWVGA and the California Department of Water Resources (DWR) entered into an agreement for the award of \$7.6 million in grant funding from the California Budget Act of 2021 Sustainable Groundwater Management Grant Program SGMA Implementation Round 1 grant solicitation (SGMA-IP). The grant funding is being used for the planning, design, environmental compliance, right-of-way acquisition, and other permitting and coordination with partnering agencies for the imported water interconnection project with AVEK.

In WY 2022, Provost and Pritchard Consulting Group (P&P) began the preparation of an Imported Water Pipeline Alignment Study to evaluate potential imported water pipeline routes and recommend a final alignment for design. The scope of work includes the following:

- Determine Capacity at Pipeline Inlet
- Determine Water Demands through 2070 for the Imported Water Pipeline
- Evaluate Potential Delivery and Connection Points
- Develop Preliminary Pipeline Alignments
- Analyze Alternative Pipeline Alignments
- Recommend a Preferred Pipeline Alignment

The Alignment Study was completed in WY 2023. It identified the three best alignments for the imported water pipeline, used a set of weighted screening criteria to identify the preferred alignment, and identified the AVEK tie-in point and the IWVWD connection point, among other tasks. In December 2022, the IWVGA

Board of Directors approved the Central Alignment as defined in the Alignment Study as the preferred alignment to proceed with further Environmental Evaluation.

In February 2023, the IWVGA contracted with P&P for the Preliminary and Final Design of the imported water pipeline and to develop the appropriate California Environmental Quality Act (CEQA) and National Environmental Policy Act (NEPA) environmental documentation for the project. The IWVGA also contracted with OPC Services (since renamed Transystems) to provide Right-of-Way (ROW) services for the Project which includes a pipeline approximately 50.6 miles in length and up to 24-inches in diameter, three pump stations, two forebay tanks, and one regulating tank.

In August 2023, P&P submitted the draft Preliminary Design Report (PDR), the first major deliverable associated with the preliminary and final design services contract. The purpose of the PDR is to set forth the key assumptions and recommendations that will be incorporated into the final design of the pipeline and appurtenant facilities. The Final PDR was submitted early WY 2024. The 30% Design submittal, which will include 30% Design Drawings, Engineer's Opinion of Probable Construction Costs, and Construction Schedule, is projected to be completed by January 2024. The 60% Design submittal is projected to be completed in March 2024.

P&P completed a preliminary CEQA Initial Study in July 2023. An Administrative Draft Environmental Impact Report (EIR)/Environmental Assessment (EA) is anticipated to be completed in March 2024. A final EIR/EA is anticipated to be completed in WY 2024. Additionally, several geotechnical and biological monitoring and surveys were completed in WY 2023. IWVGA Staff have reviewed and approved drafts of the Noise & Groundborne Vibration Impact Analysis and Air Quality & Greenhouse Gas Impact Analysis Technical Studies. Coordination with California Department of Fish and Wildlife, United States Army Corps of Engineers, and State Water Resources Control Boards is ongoing and applications for permits have been submitted. Public scoping meetings for CEQA were held in Ridgecrest and California City on August 23, 2023 and August 24, 2023, respectively. The BLM held a NEPA 30-Day Scoping Period in WY 2024 which began on October 5, 2023 and ended on November 4, 2023. Additional public outreach and scoping meetings will take place in WY 2024.

In WY 2023, Transystems began ROW services and obtained 50 Right-of-Entry agreements from property owners for 48 parcels along the alignment to allow performance of biological/technical studies and geotechnical borings. Transystems is coordinating with California Fish and Wildlife and the County

regarding ROW requirements for the project. A Right-of-Way Acquisition Plan will be completed in WY 2024.

In WY 2023, the Phase 1 Surface Percolation Replenishment Study Technical Memorandum was completed. The study identified locations for potential recharge basins for further investigation with the goal of ultimately assessing feasibility to develop a surface spreading project. The IWVGA staff and TAC concluded that surface percolation would not be feasible in the IWVGB due to the hydrogeology and depth to water. Consequently, a treated imported water project to deliver water directly to water users in the Indian Wells Valley was determined to be the most feasible imported water project.

3.1.3 Project 2: Optimize Recycled Water

The IWVGA Board of Directors adopted Resolution Number 02-20 on November 19, 2020, formally creating the Recycled Water Program. The IWVGA Board of Directors also approved an option agreement for purchase of recycled water from the City of Ridgecrest at the November 2020 meeting.

On July 11, 2022, Capital Core conducted a preliminary scoping meeting with Bureau of Reclamation (BOR) staff regarding the BOR's Title XVI programs which provide funding for planning, design, and construction of water recycling and reuse projects. The preliminary scoping meeting determined that the IWVGA's recycled water project is eligible for funding under the Title XVI Reclaim and Reuse Program. In July 2022, the IWVGA Board of Directors authorized Staff to prepare a Title XVI Feasibility Study to submit to the Bureau of Reclamation (BOR) for funding under the Title XVI Reclaim and Reuse Program. The Feasibility Study was completed in WY 2023 and submitted to BOR in March 2023. It consists of the following:

- Project Description and Study Area
- Statement of Problem and Need
- Water Recycling Opportunity
- Description of Alternatives
- Economic Analysis of the Project
- Justification of the Recycling Project
- Environmental Considerations and Effects (NEPA)
- Legal and Institutional Requirements
- Research Needs for the BOR

BOR granted final approval of the Title XVI Feasibility Study in early WY 2024.

In January 2023, the IWVGA applied for funding through the DWR Urban Community Drought Relief Grant Program for Recycled Water Project planning costs. DWR did not award the IWVGA with grant funding for this project in part due to concerns that the overall cost per-acre foot of water produced was prohibitive. Due to a lack of funding for Recycled Water Project, as currently envisioned, the IWVGA Board of Directors directed Staff to halt work on the Project. In WY 2024, alternative uses for recycled water will continue to be considered.

3.1.4 Project 3: Conservation Efforts

Through Proposition 1 funding, the IWVGA completed a pilot water conservation program in early WY 2023 targeting groundwater users located in severely disadvantaged communities (SDAC). The program consisted of a rebate program for installation of water conservation devices, water audits and leak detection surveys, and the preparation of drought management and water conservation plans.

Water audit and leak detection surveys, initiated in WY 2022 and finalized in WY 2023, were performed for the following SDAC communities:

- Eastern Inyokern Mutual Water Company
- China Lake Acres Mutual Water Company
- Searles Domestic Water Company
- South Desert Mutual Water Company & West Valley Mutual Water Company

The reporting for these surveys was finalized in WY 2023. The water audit and leak detection survey for Inyokern Community Services District was completed in WY 2021.

During WY 2022, work began on developing Water Shortage Contingency Plans the following SDAC Communities:

- China Lake Acres Mutual Water Company
- Eastern Inyokern Mutual Water Company
- Inyokern Community Services District
- West Valley Mutual Water Company

The purpose of these plans is to provide strategies to protect the water supply during various events including a water shortage that would require mandatory conservation measures. These plans were completed in WY 2023.

The above-mentioned surveys and plans can be found on the DMS at the following site: www.iwvgs.com.

Indirectly, the IWVGA extraction fees encourage and incentivize individual water saving and conservation practices. Additionally, the IWWWD has continued its conservations efforts for its customers, independent of the IWVGA, as described in IWWWD's 2020 Urban Water Management Plan. The IWVGA intends to cooperatively work with the IWWWD in WY 2024 to develop new conservation projects.

3.1.5 Project 4: Shallow Well Mitigation Program

Continued impacts at shallow wells (declining water levels and degraded water quality) are anticipated while management actions and GSP projects are being implemented due to poor or degraded water quality and overdraft conditions. Predictive modeling results and hydrographs of measured data indicate declining water levels suggest some shallow wells are likely to be impacted before sustainability is reached. The IWVGA continued development of the Shallow Well Mitigation Program in WY 2023. Funding for shallow well mitigation is through the adopted mitigation fee (Ordinance 03-20). The Shallow Well Mitigation Program is structured such that the IWVGA Board of Directors, along with appropriate technical Staff, conduct evaluations of submitted wells on a case-by-case basis to determine the appropriate mitigation measures and financial assistance. The Shallow Well Impact Report Form and Emergency Assistance Report Form can be found on the IWVGA website: <https://iwvga.org/reports>.

In WY 2023, the Water Resources Manager (WRM) evaluated applications to the IWVGA for shallow well mitigation funding. Based on the recommendations of the WRM and staff, the IWVGA Board has approved one application for partial funding to replace a well impacted by declining groundwater levels. One application was declined due to not meeting the criteria for funding. Two applications are currently being reviewed. Lastly, one application has been redirected to a more appropriate potential funding source.

In addition to implementing the Shallow Well Program to address individual well impacts, the IWVGA submitted an application to DWR under the Urban Community Drought Relief Grant Program to receive grant funding to consolidate small, vulnerable, well systems in disadvantaged areas into the IWWWD. DWR awarded the IWVGA \$3,345,000 in June 2023. The grant agreement is anticipated to be finalized in early

WY 2024. Implementation of this project would mitigate impacts to shallow wells and could reduce the number of applicants for the Shallow Well Program.

3.1.6 Project 5: Dust Control Mitigation Program

Implementation of the Fallowing Program and voluntary cessations of agricultural operations could potentially result in loss of vegetation and an increase in windblown dust and sand, due to the climate of the Indian Wells Valley which would require mitigation in order to eliminate undesirable results. Significant groundwater production reductions and cessation of agricultural operations have not yet occurred. Additionally, the IWVGA does not have a funding source to implement the program at this time. Consequently, no work on this project was completed in WY 2023.

3.1.7 Project 6: Pumping Optimization Project

Evaluation of modeling results generated during development of the GSP for the proposed groundwater management and project scenarios showed that some current groundwater pumping may need to be redistributed in the IWVGB to reduce concentrated pumping centers that would lead to continuing localized declining groundwater levels and corresponding continuing impacts to shallow domestic wells.

Pumping throughout the Basin is influenced by the implementation of the other projects and management actions. This project will need to be evaluated after other projects and management actions are implemented and the basin impacts of said projects are evaluated. Consequently, no work on this project was completed in WY 2023.

3.2 Progress Towards Sustainable Management Criteria

As discussed previously, the IWVGA has identified four sustainability indicators with documented historical and/or current undesirable results in the IWVGB:

- Chronic lowering of groundwater levels
- Reduction of groundwater in storage
- Degraded water quality
- Potential for groundwater pumping related land subsidence

Quantifiable sustainable management criteria have been established for sustainability indicators with current or historical impacts to numerically define when undesirable results are occurring and to define achievable targets for reaching and maintaining sustainability. These sustainable management criteria

include minimum thresholds, measurable objectives, and interim milestones. Development of these criteria relied upon information about the IWVGB developed in the hydrogeologic conceptual model, current and historical groundwater conditions, and the water budget. Additional information regarding the development of sustainable management criteria can be found in the GSP.

As an interim indicator of progress towards achieving sustainability, the applicable sustainability indicators are evaluated by the interim milestones at 5-year increments. The measurable objectives for the applicable sustainability indicators are desired benchmarks to be reached by year 2040, although it is acceptable for conditions to be managed in the range between the minimum threshold and measurable objective (operating range). If conditions fall below the minimum threshold after year 2040, undesirable results are occurring and sustainability has not been reached.

The IWVGA selected representative monitoring sites to be used to specifically measure and monitor groundwater conditions caused by the sustainability indicators, and to evaluate the efficacy of proposed projects and management actions achieving sustainability. These sites were selected based on evaluation of the best available data. As more data become available through monitoring and data collection, the representative sites will be reevaluated for effectiveness at representing basin-wide conditions. This reevaluation process will occur prior to the five-year GSP update.

In general, the IWVGA anticipates the continuation of groundwater level declines until projects and management actions are fully implemented and the basin has stabilized. Sustainability is not required to be reached until 2040. The first interim milestones will be evaluated in 2025.

Sustainable management criteria established for the IWVGB can be monitored on the public data DMS at the following site: www.iwvgsp.com. A summary of data is provided in the subsections below.

3.2.1 Chronic Lowering of Groundwater Levels

Currently, ten representative monitoring sites have been selected in the IWV GSP² to monitor the chronic lowering of groundwater levels throughout the IWVGB. These wells were selected to have good spatial distribution throughout the IWVGB and across the pumping centers and good predictive ability to monitor

² Section 4.4.2.6 (Representative Monitoring Sites) on the IWV GSP outlines how and why wells were selected as representative monitoring sites for the chronic lowering of groundwater levels.

the effectiveness of projects and management actions that will be implemented to limit the decline of groundwater levels. The ten well locations are shown in Figure 3-1.

Among the ten representative monitoring wells, three of them do not have established sustainable management criteria at this point in time. Sustainable management criteria will be established during the reevaluation process of all representative monitoring sites which will occur as part of the five-year GSP update. Representative monitoring sites and their respective sustainable management criteria can be found on the IWV DMS (<https://iwvgsp.com/GSP-Dashboard/map.php>). At present, groundwater levels at six of the representative sites are above the measurable objectives, the target level in 2040 when sustainability is reached. Groundwater levels at one representative site is within the operating range between the measurable objective and the minimum threshold. Accordingly, undesirable results have not been observed.

Table 3-1: Representative Monitoring Sites for Chronic Lowering of Groundwater Levels

Monitoring Site	Screen Interval	Spring 2023 Measurement (ft msl) ¹	Minimum Thresholds (ft msl)	Measurable Objective (ft msl)	Note
USBR-01	1,750-1,770	2,668	2,659	2,664	Above measurable objective
USBR-03	1,850-1,870	2,165	-	-	Criteria not determined yet
USBR-04	1,190-1,200	2,130	2,110	2,125	Above measurable objective
USBR-05	850-870	2,159	2,151	2,156	Above measurable objective
USBR-06	330-350	2,170	2,166	2,171	Within operating range
MW 32	1,900-1,920	2,140	2,119	2,134	Above measurable objective
Kerr McGee	681-881	2,148	2,138	2,145	Above measurable objective
Sandquist Spa	135-191	2,170	2,162	2,167	Above measurable objective
Inyo	457-477	<2142/Dry	-	-	Criteria not determined yet
George Air Corridor	320-380	2,159	-	-	Criteria not determined yet

¹ ft msl = feet mean sea level

Except approximately 5 feet of water level decline at Inyo well, water level measurement at other representative monitoring sites fluctuated less than 1 foot in WY 2023, which indicates that the first interim milestones will be met in 2025 because groundwater level declines are anticipated to continue until projects and management actions are fully implemented. Groundwater elevation data are discussed more thoroughly in Chapter 5.

3.2.2 Reduction of Groundwater in Storage

Groundwater in storage will continue to be reduced until the IWVGB is operated within the sustainable yield. The 2025 interim milestone for change of groundwater in storage is a loss of approximately 82,000 AF since 2020. The cumulative change in storage from WY 2020 to WY 2023 is approximately 58,000 AF. According, no undesirable results has been observed. The annual change of groundwater in storage within the measured study area of the IWB Basin from Spring 2022 to Spring 2023 is estimated to be a loss of 12,370 AF in the IWV main basin and 5,513 AF in the El Paso Subarea based on changes to groundwater levels at 77 wells (see Table 5-1). Estimated change in groundwater storage is discussed in Chapter 5.3.

3.2.3 Degraded Water Quality

Currently, ten representative monitoring sites have been designated to monitor water quality, as represented by total dissolved solids (TDS) concentrations. These representative monitoring sites are shown in Figure 3-2. Groundwater water quality data was limited at the time of developing the GSP and establishing sustainable management criteria. Since the GSP adoption, water quality data has been collected to establish baseline conditions. Sustainable management criteria will be established during the reevaluation process of all representative monitoring sites which will occur prior to the next GSP Periodic Evaluation. The status of TDS concentrations at the current representative monitoring sites are summarized in Table 3-2 below.

Table 3-2: Representative Monitoring Sites for Degraded Water Quality

Well	Screen Interval	Fall 2022 / Most Recent Measurement (mg/l)	Minimum Thresholds (mg/l)	Measurable Objective (mg/l)	Note
AB 303-5	905-1,005	160	-	-	Criteria not determined yet
IWVWD Well 33	TD=1,020	280 ¹	500	310	Below measurable objective
Owens Peak South 01		290 ¹	500	300	Below measurable objective
IWVWD Well 30	TD=1,200	200 ¹	500	240	Below measurable objective
Hometown Water Well 01		370 ¹	500	370	At measurable objective
IWVWD Well 11	TD=620	580 ¹	600	530	Within operating range
Sandquist Spa	135-191	340	-	-	Criteria not determined yet
West Valley Mutual 01		500 ¹	600	500	At measurable objective
26S/38E-01M05	299-359	530	-	-	Criteria not determined yet
26S/39E-06P01		500 ¹	-	-	Criteria not determined yet

¹ mg/L = milligram per liter. Measurement dates range from 2019 to 2021 due to monitoring schedule.

TDS concentrations at five of the representative sites are at or below the Measurable Objectives. TDS concentrations at one representative site are within the operating range between the Minimum Threshold and Measurable Objective. Four representative monitoring well sites do not have established sustainable management criteria due to lack of data at the time of selection. No undesirable results have been observed.

As discussed previously, the representative monitoring sites will be reevaluated for effectiveness at representing basin-wide conditions prior to the next GSP evaluation. Sustainable management criteria will

be established for the remaining representative wells during the reevaluation process which will address DWR's recommended corrective action.

See Section 7.1 for additional data on TDS concentrations.

3.2.4 Land Subsidence Related to Groundwater Pumping

Due to implementation of projects and management actions that will result in stabilization of groundwater levels, land subsidence is not anticipated to occur. Accordingly, the Measurable Objective and interim milestones are set at the long-term historical rate of subsidence, 0.04 inches/year. (See the GSP for additional information.) No representative monitoring sites to measure land subsidence off of the NAWS China Lake have been selected at this time. The IWVGA intends to periodically monitor land subsidence conditions throughout the IWVGB as datasets become available and as necessary to ensure no undesirable groundwater conditions are occurring. Periodically and at least every five years, the IWVGA will request any available land subsidence data from the U.S. Navy at their Supersonic Naval Ordnance Research Track (SNORT) alignment. No land subsidence data was collected by the U.S. Navy during WY 2023.

The U.S. Geologic Survey (USGS) does not identify the IWVGB as a region which has experienced historical land subsidence due to groundwater production, peat loss, or oil production (USGS, 2021). Interferometric Synthetic Aperture Radar (InSAR) data measuring vertical displacement is available on the SGMA Data Viewer (DWR, 2023b). The data indicate the IWVGB (including El Paso) experienced a displacement between -0.1 and 0.1 feet in WY 2023. Accordingly, no significant land subsidence has occurred during WY 2022. No additional land subsidence data has been published in WY 2023.

3.3 Progress Made on Addressing Recommended Corrective Actions

In its GSP Assessment Staff Report for the IWV GSP, DWR provided seven RCAs to be considered by the IWVGA prior to the first Periodic Evaluation of the GSP. The following table documents each RCA and the current progress and plan to address DWR's recommendations.

Table 3-3: Recommended Corrective Actions Summary

Recommended Corrective Action Summary	Current Progress and Next Steps
<p>RCA 1</p> <ul style="list-style-type: none"> • Provide additional information on the required, ongoing communications elements required in the GSP Regulations. • Address Communication & Engagement Plan. 	<ul style="list-style-type: none"> • The Communication & Engagement Plan was amended in WY 2023. • Ongoing communication with the public occurs regarding relevant and important GSP implementation topics.
<p>RCA 2</p> <ul style="list-style-type: none"> • Investigate the hydraulic connectivity of the vertical and lateral relationships between the three hydrogeologic zones. • Provide a timeline and discuss the steps that will be taken to fill the data gap identified in the Plan related to groundwater monitoring. • Reassess the groundwater level and groundwater quality monitoring networks. 	<ul style="list-style-type: none"> • Hydrogeologic zones have been investigated and data is being incorporated into the GSP model. • Data gaps are continuously being evaluated and filled. A comprehensive list and discussion of data gaps will be provided in the next GSP Plan Amendment. • The groundwater level and groundwater quality monitoring networks, particularly representative monitoring sites, were re-evaluated in WY 2024 and will be updated in the next GSP Plan Amendment.
<p>RCA 3</p> <ul style="list-style-type: none"> • Update water budget • Revise climate change projections based on data obtained from addressing data gaps, as needed. 	<ul style="list-style-type: none"> • GSP model is currently being updated with additional data. • Updated water budgets will be determined in WY 2024. • Climate change model runs will be performed in WY 2024.
<p>RCA 4</p> <ul style="list-style-type: none"> • Update the Plan to include projects and management actions sufficient to eliminate perpetual overdraft currently projected beyond the fifty-year planning and implementation horizon. • Develop a contingency plan for if imported water is not secured. • Provide updates related to the negotiated details and implementation of the imported water project options. 	<ul style="list-style-type: none"> • All Projects and Management Actions are currently being re-evaluated. • Additional modeling runs will be performed in WY 2024. • A contingency plan is being developed and will be provided in the next GSP Plan Amendment. • Updates on the imported water project are provided in each Annual Report.
<p>RCA 5</p> <ul style="list-style-type: none"> • Identify and clarify groundwater conditions that would produce undesirable results. • Identify minimum thresholds to prevent conditions in the Basin from causing those undesirable results. 	<ul style="list-style-type: none"> • Groundwater conditions and undesirable results will be re-evaluated and updated in the next GSP Plan Amendment. • Sustainable Management criteria, including minimum thresholds, will be established at sites not yet with criteria in WY 2024 after additional modeling runs are completed.
<p>RCA 6</p> <ul style="list-style-type: none"> • Establish sustainable management criteria at all representative monitoring locations. 	<ul style="list-style-type: none"> • Sustainable Management criteria will be established at sites not yet with criteria in WY 2024 after additional modeling runs are completed.

Recommended Corrective Action Summary	Current Progress and Next Steps
<p>RCA 7</p> <ul style="list-style-type: none"> Update the data management system to reflect correct, current, and complete information. Describe rationale for management area boundaries, if applicable. 	<ul style="list-style-type: none"> The DMS is continuously updated as new data is collected. Management areas have been evaluated with the El Paso management area to be proposed to DWR in the next GSP Plan Amendment.

3.4 Outreach and Engagement

A guidance document on communication and engagement (C&E Plan) was developed by the IWVGA in 2018 and revised in WY 2023. According to the C&E Plan, the IWVGA will use individual mailings and newsletters, website updates, potential use of social media, public notices and display advertisements in newspapers, focused workshops, board meetings, and provide hard copy materials along with CDs to public libraries as outreach methods to inform the public regarding important GSP implementation tasks.

The IWVGA conducts regular monthly Board meetings to support the implementation of projects and management actions that support Basin sustainability, and to receive input from the public. The IWVGA Policy Advisory Committee (PAC) meets regularly to advise the IWVGA on policy matters related to GSP implementation. The IWVGA Technical Advisory Committee (TAC) advises the IWVGA Board and IWVGA Water Resources Manager on technical matters, as needed.

In WY 2023, IWVGA staff began implementing some of the revisions to the C&E plan including developing Frequently Asked Questions (FAQ) sheets and other outreach materials. This work will continue into WY 2024.

Page Intentionally Left Blank

Chapter 4 Hydrologic Conditions

The California Code of Regulations (CCR) requires that GSP Annual Reports contain information on current and historical water year types (23 CCR § 356.2). DWR issues water year classifications for some areas of the state, including the Sacramento River and San Joaquin River basins. The DWR historical data set covers the period from WY 1931 to 2022; the classification for WY 2023 is still not yet available.

GSAs have the option to (1) develop their own water year types based on best available information (23 CCR Section 354.18d), or (2) use the data recently developed by DWR for the water budget. The suitability of the DWR water year type index will be assessed for future reports; at this time, a classification for the most recent water year is not yet available from DWR. A water year type index (Attachment B), based on local precipitation data in the IWVGB, was developed previously for the baseline groundwater model (GSP Appendix 3-H, Stetson 2020a) and the GSP Annual Reports for WYs 2019-2022 (Stetson, 2020b, 2021, 2022a, 2023). Use of that index is continued in this annual report.

The IWVGB water year type index is based on historical precipitation data from 1945-2023 at the China Lake NAF station and has five hydrologic categories. The categories are illustrated in the annual precipitation exceedance curve in Figure 4-1. The five types are Wet, Above Normal, Normal, Below Normal, and Dry. Table 4-1 shows the thresholds for determining water year type. The thresholds correspond to the vertical lines dividing the categories in Figure 4-1. WY 2023 was a Wet year, with 8.27 inches of rain at the index station. Table 4-2 and Attachment B lists the water year type since 2015 and the historical classifications of water year type since WY 1945, respectively. WY 2023 is a historical wet year, with only three years having higher amounts of rainfall since 1945. WY 1992, over thirty years ago, was the last time rainfall was more than WY 2023. The basin had been experiencing an historical drought (2012-2022) prior to the WY 2023 wet year. The precipitation in WY2023 broke this latest drought trend, with only 4% of years (1945-2023) having more precipitation than this Wet year that had 234% of the average rainfall (3.53 inches). Included in the annual total of 8.27 inches of rainfall is a very wet August 2023 with 4.33 inches of precipitation at the index station due to monsoon weather. A nearby precipitation gage at Trona (ID No. 49035) also experienced over four inches of rainfall during the month of August 2023. Even without this wet August, WY 2023 would have been close to Above Normal rainfall for the entire year.

Table 4-1: Percent Exceedance Ranges and Dividing Thresholds for Five Water Year Types

Year Type	Percent Exceedance Range (%)	Threshold Between Year Type (in/yr) ¹	Number of Years in Historical Record (WY 1945-2023)
Wet	0% - 10%	6.0	8
Above Normal	>10% - 33%	4.1	18
Normal	>33% - 67%	2.1	27
Below Normal	>67% - 90%	1.3	18
Dry	>90% - 100%	n/a	8
		Total years	79

1 Thresholds based on Percent Exceedance Ranges for 1945-2023 period.

Table 4-2: Water Year Types based on Precipitation at China Lake NAF Station (No. 041733)

WY	Annual Precipitation (in/yr)	Percentage of Average	Percent Exceedance Rank	Water Year Type
2015	3.67	104%	45%	N
2016	1.38	39%	87%	BN
2017	4.61	130%	26%	AN
2018	1.43	40%	86%	BN
2019	6.13	173%	8%	W
2020	5.57	158%	15%	AN
2021	0.58	16%	96%	D
2022	1.87	53%	73%	BN
2023	8.27	234%	4%	W

Notes: W = Wet, AN = Above Normal; N = Normal; BN = Below Normal; D = Dry.

Percentage of average and percent exceedance range calculated based on the 1945-2023 period of record.

Chapter 5 Groundwater Elevation Data

Since 1946, groundwater data have been collected in the IWVGB for studies conducted by the U.S. Navy, USGS, DWR, U.S. Bureau of Reclamation (USBR), and other agencies. In 1995, a groundwater monitoring program (GWMP) was established between Kern County Water Agency (KCWA) and the U.S. Navy collecting groundwater levels throughout the IWVGB during the wet (spring) and dry (fall) seasons from approximately 100 to 150 wells. Since 2020, the Indian Wells Valley Groundwater Authority (IWVGA) coordinates with KCWA and the Navy for the semi-annual monitoring collection of groundwater levels. Since WY 2022, the IWVGA's Water Resource Manager has been required to supply most of the field staff needed to measure groundwater levels. This additional support for KCWA and the Navy allowed for major improvements in collecting observation data during WY 2022 and has continued into WY 2023.

The GWMP included 176 monitoring sites during WY 2023 (See Attachment C for all wells in the GWMP). Depths to water (DTW) measurements were collected at 147 sites in Fall 2022 and 151 sites in Spring 2023. Three wells were added to the GWMP from Fall 2022 to Spring 2023 to fill data gaps and provide new groundwater levels³ (Figure 5-2 shows these well locations). Attachment D contains measured DTW data, Land Surface Datum (LSD) and resulting groundwater elevations (feet, mean sea level) for WY 2023. These data were filed on DWR's SGMA portal and appended to DMS website (*iwvgs.com*). Groundwater elevation data were used to produce equipotential contour maps and hydrographs and are discussed below in this section of the annual report.

Due to the record snow and rainfall experienced in California during the winter months in WY 2023, DWR requested GSAs, including the IWVGA, to increase the frequency of groundwater level collection from the required biannual measurements. The purpose of this increase was to allow basins to better understand the response to groundwater levels associated with wet years and better understand the best time to capture the occurrence of seasonal high groundwater levels. Consequently, supplemental monitoring was conducted during May, August, and December 2023 to supplement the regular October and March bi-annual monitoring. All groundwater level data is posted on the DMS website (*iwvgs.com*) and on DWR's SGMA data portal.

³ New wells in the GWMP: 25S/39E-29N01, 26S/38E-17C01, 26S/39E-25K01, 26S/39E-27C01, 26S/39E-35B

5.1 Groundwater Elevation Contour Maps

KCWA's Geologist⁴ produced Fall 2022 and Spring 2023 groundwater elevation and depth to water contours for this WY 2023 Annual Report. Figures 5-1 and 5-2 show the Fall 2022 and Spring 2023 groundwater elevation contours, respectively. Both figures also include the location of measured groundwater level monitoring wells used in the analysis, the groundwater basin boundary, and the watershed extents for Indian Wells Valley. Contours are dashed to show the uncertainty where there are limited data available.

The groundwater elevation contour maps show the general flow of groundwater from the surrounding mountains towards China Lake playa. Groundwater flows from Rose Valley in the northwest (about 2,250 feet, msl), the Sierra Mountain front fan deposits (about 2,190 feet, msl) along the west, the Argus Range Mountain front fan deposits from the east (about 2,180 feet, msl) and from the El Paso Subarea (2,800 feet, msl) in the southwest towards the playa at the center of the basin. Pumping centers form depressions near discharge areas in the northwest (about 2,170 feet, msl), southwest (about 2,150 feet, msl), and southeast (about 2,120 feet, msl). Groundwater mounding can also be observed near the wastewater treatment plant on the NAWS China Lake (2,190 feet, msl). There is a fault zone causing steep groundwater level contours from the El Paso Subarea towards the main IWVGB.

Figures 5-3 and 5-4 show contours of the depth to groundwater below land surface. These contours indicate the depth that would need to be drilled to intercept the groundwater table and produce water from a well. In general, depth to groundwater below land surface appears to be greatest in areas with the highest elevations along the Sierra Nevada and the El Paso Mountains. Depth to groundwater levels decrease at lower elevations at the playa and towards Salt Wells Valley.

5.2 Hydrographs

Hydrographs have been developed for all wells in the IWV Groundwater Monitoring Program (GWMP) and are posted on the DMS website (www.iwvgs.com). Hydrographs for 14 selected well sites are provided in Attachment E (see also Figure 5-5), which include the designated representative monitoring wells for chronic lowering of groundwater specified in the GSP used to track Basin management. The selected wells include seven nested multi-level piezometers (note: data for nested multi-level

⁴ Michelle Anderson, PG; Kern County Water Agency (KCWA) geologist.

piezometers appear on the same hydrograph), for a total of 30 groundwater level measurements. Groundwater level data collected by KCWA, the Navy, IWVWD and other agencies (Historical data collected in IWV from DWR, USGS, and USBR are also included on the hydrographs) were used to produce these hydrographs. Groundwater level data for the majority of the hydrographs begin in the late 1980s and early 1990s when the wells were installed, with the exception of the Inyo Well. The Inyo Well (27S/39E-07R01), located in the southwest of the IWV main basin has the longest period of record for groundwater level data in the basin dating back to 1946.

The hydrographs in Attachment E show historical changes of groundwater levels throughout the IWVGB. The most recent changes of groundwater levels at the 14 selected well locations shown on Figure 5-5 are summarized below.

- USBR-10 nested piezometers (Attachment E, page 1, upper graph)
These nested wells are located in the northwest near Nine Mile Canyon Road (mountain front recharge) and south of Little Lake (Rose Valley subsurface flow). Historically there were four piezometers at USBR-10, but now only 3 of the piezometers are able to be measured⁵. Rising groundwater levels were observed at the three measured piezometers from Spring 2021 to Spring 2022. Groundwater levels in the shallow, shallow-mid and deep piezometers declined 2.88, 2.80, and 2.78 feet, respectively.
- USBR-6 nested piezometers (Attachment E, page 1, lower graph)
These nested wells are located on the Navy Base just inside the Navy fence line in the northwest adjacent to alfalfa fields, and near fan deposits from Sand Canyon. While the mid and deep piezometers saw a water level decline of 0.84 and 0.73 foot, respectively, the shallow piezometer saw an increase of 0.78 foot from Spring 2022 to Spring 2023.
- USBR-5 nested piezometers (Attachment E, page 2, upper graph)
These wells are located in the northwest at the base of Indian Wells Canyon (mountain front recharge) and approximately 0.5 mile from the agricultural pumping center. There was a water level decline in all three piezometers from Spring 2022 to Spring 2023 at 0.75 foot (shallow), 0.53 foot (mid) and 0.53 foot (deep).
- NR-2 nested piezometers (Attachment E, page 2, lower graph)
These wells are located in the northwest about one mile east of USBR-5 and near the agricultural pumping center. None of the three piezometers (shallow and deep) was measured during the Fall 2022 and Spring 2023 measuring events.
- Sandquist Spa Well (Attachment E, page 3, upper graph)

⁵ Since Fall 2005 the mid-deep piezometer at USBR-10 has not been able to be measured (well collapsed, these data are posted for historical reference only).

This well is located on the Navy Base between the agricultural pumping centers and the playa (discharge area). The observed groundwater level decline was 0.71 foot from Spring 2022 to Spring 2023.

- Kerr McGee 17 (Attachment E, page 3, lower graph)
This well is located on the Navy Base east of Highway 395 about 3 miles southeast of NR-2 just inside the Navy fence line. From Spring 2021 to Spring 2022, groundwater level in this well declined 0.29 foot.
- MW-32 nested wells (Attachment E, page 4, upper graph)
These wells are located along Business Highway 395 to the east of Inyokern, in the vicinity of IWVWD pumping wells. From Spring 2022 to Spring 2023, water level rose 18.36 feet, 6.92 feet and 0.34 foot in the shallow, mid and deep piezometers, respectively.
- USBR-4 well (Attachment E, page 4, lower graph)
This well is also located along Business Highway 395, about 2 miles east of MW-32. A groundwater level increase of 9.65 feet was observed at this well from Spring 2022 to Spring 2023.
- 26S/39E-32L1 (Attachment E, page 5, upper graph)
This well is located about 2 miles south of the junction of U.S. Highway 395 and California State Route 178. Groundwater levels have shown a steady decline since monitoring began in 2007. Groundwater levels dropped 0.79 foot from Spring 2022 to Spring 2023 at this well.
- George Air Corridor Well (Attachment E, page 5, lower graph)
This well is located on the Navy Base in the southeast area on the basin. Groundwater levels have shown a steady decline since monitoring began in 1989. However, a slight water level increase (0.04 foot) was observed from March 2022 to March 2023.
- USBR-3 nested piezometers (Attachment E, page 6, upper graph)
This nested well is located to the west of Ridgecrest near the new IWVWD production wells. From Spring 2022 to Spring 2023, groundwater level increased 0.98 foot and 0.14 foot at the shallow and deep piezometers, respectively. At the mid piezometer, a water level decline of 1.64 feet was observed during that same one-year period.
- Inyo well (Attachment E, page 6, lower graph)
This well has the longest period of monitoring data, since 1946, and is located in the southwest area of the IWVWD new production wells. This well was deepened once and was dry during spring 2023 groundwater level measurements (425 feet depth). Groundwater levels have shown a steady decline since the early 1950s. This well is in poor condition and may be dry. Funding is being investigated for well replacement.
- AB303-05 well (Attachment E, page 7, upper graph)
This well is located in the El Paso subarea to the southwest of the main IWVGB where there isn't any significant pumping. Stable groundwater levels have been observed at this well since 2007,

with a slight rise in recent years. Groundwater level declined 2.50 feet from Spring 2022 to Spring 2023 at this well.

- USBR-1 nested piezometers (Attachment E, page 7, lower graph)

This nested well is also located in the El Paso subarea of the IWVGB where there isn't any significant pumping, southwest of a fault that separates this subarea from the main IWV groundwater basin. Steady groundwater levels have been observed at all four piezometers since about 1995, with a slight rise in recent years. There was no water level measurement at the deep piezometer after May 2020. From Spring 2022 to Spring 2023, water level at the shallow piezometer increased 0.20 foot, while the shallow-mid piezometer saw a water level decline of 2.03 feet.

5.3 Estimated Change in Groundwater Storage

Groundwater levels have declined in many parts of the IWVGB during WY 2023. There are some areas that show little change, or even an increase in groundwater levels, primarily in the El Paso subarea, where there is little or no groundwater production. Two different methods were used to evaluate the changes in groundwater levels from Spring 2022 through Spring 2023: (1) map color coded comparison of measured groundwater level change, and (2) modified Thiessen polygon method using 77 monitoring wells distributed throughout the basin to estimate storage changes.

5.3.1 Groundwater Level Change from Spring 2022 to Spring 2023

Groundwater levels were measured at 117 wells during both Spring 2022 and Spring 2023. These measurements were compared to evaluate the annual groundwater level change across the basin. Figure 5-6 shows the annual groundwater elevation change from Spring 2022 to Spring 2023 displayed as gradational colors on a map for each of these monitoring wells. This visual method of representing the available data on a map shows the distribution of lowered groundwater levels and where no change or an increase in groundwater levels occurred during the last year. Orange and red dots at 17 wells represent observations with a 1-foot to 6.3-foot drop in groundwater levels; and yellow and light orange dots at 51 wells display groundwater levels dropping up to 1 foot. The highest levels of groundwater elevation change observed (red dots) typically appear to correlate with pumping and discharge areas. The largest decline in groundwater levels was observed at IWV-MW-02, located near the southwest pumping center.

From Spring 2022 to Spring 2023, there were a total of 6 monitoring wells that saw a water level drop of more than 1-foot (red and orange dots) to the southwest of Inyokern, where an increase or no change in groundwater levels were observed during the previous 3-year period from Spring 2019 to Spring 2022.

The cause of this drop in groundwater levels is not fully understood. These monitoring wells are located to the west of the surface expression of the Freeman fault (shown as a red NW/SE line on Figure 5-6). IWVWD pumps groundwater to the east of Freeman fault and at a distance from these wells located in the alluvial fans of the Sierra Nevada. Further investigation is warranted to determine what these WY 2023 dropping groundwater levels indicate.

An increase or no change in groundwater levels (no loss of groundwater storage) are observed in the wells shown as green and blue dots in Figure 5-6. This condition seems to occur mostly outside of the Inyokern area. The cause of these increases to the groundwater levels in these areas is not fully understood .

5.3.2 Estimating Storage Change Using Modified Thiessen Polygon Method

Changes to groundwater in storage are estimated each year for the Annual Report and to be used for managing IWV's water resources. In this Section, changes to groundwater in storage for WY 2023 have been calculated for a portion of the aquifer where groundwater levels are measured for the GWMP. The distribution of measured data from GWMP monitoring wells are shown on the groundwater elevation and groundwater depth contour maps (Figures 5-1 through 5-4) and listed in Attachment D. This area (188,971 acres), where available groundwater level data exists and the major pumping occurs, represents about half of the total GSA Basin (381,746 acres). Groundwater modeling would be required to calculate how basin overdraft and the decline of groundwater in storage extends beyond this area to the edges of the GSA basin. Supplemental modeling using a partially updated GSP model is underway, but not complete for this Annual Report. Modeling methods will be reviewed for the 5-year GSP Report. Spring 2023 groundwater level measurements were compared with Spring 2022 measurements using a modified Thiessen Polygon Method.

5.3.2.1 Modified Thiessen Polygon Method

The Thiessen polygon method is a standard approach (Thiessen, 1911; Dunne et al., 1978) of averaging point rainfall values according to an areal distribution and can be applied to other datasets. This method distributes data collected at discrete points to the basin area by forming polygons, with each polygon containing one station with measured data. Applying this method to a groundwater aquifer assumes that the groundwater level data at the monitoring well represents the average groundwater level throughout the area represented by that particular polygon. The volume of groundwater change within each polygon

is the product of (1) area, (2) specific yield (Sy^6), and (3) measured water level change during a given period of time. This calculation for each polygon is then summed up to calculate the total volume of groundwater change within the specified study area of the basin.

Modifications were made to the Thiessen Polygon Method based on comments received from the TAC to earlier annual reports (WY 2019 and WY 2020) using this method. These modifications were first used in the WY 2022 Annual Report and carried forward in this and subsequent Annual Reports. These modifications provide an estimate of changes to groundwater in storage within a subarea of the full basin with limitations. This estimate does not consider the changes in storage outside of the study area of the modified Thiessen Polygon Method where there aren't measurements, but it does provide an indication of whether the basin is gaining or losing groundwater in storage. It would require numerical modeling to estimate how the basin overdraft extends to the edges of the basin⁷. See the WY 2022 Annual Report for a thorough description of the modifications to the Thiessen Polygon Method used here and the limitations of the approach (Stetson, 2022).

The outer boundary of the study area for applying the modified Thiessen Polygon Method generally follows the extents of groundwater level contour maps developed by KCWA. Figure 5-7 shows the full extents of the GSA boundary and the study area where groundwater measurements exist. The study area was first discretized into Thiessen polygons using perpendicular bisectors and GIS. These polygons were then modified using Angster et al. (2020) surface rupture and fault maps. The resulting polygons and surface faults are shown on Figure 5-7. Attachment F summarizes the resulting areas for each of the 77 polygons developed for this analysis.

Monitoring wells used for this analysis were considered using the following criteria: (1) long and continuous spring water level record; (2) monitoring well's condition and access assuring that the groundwater level measurement will continue for the foreseeable future; (3) spatial distribution throughout the basin; (4) selecting the shallowest piezometer for nested monitoring wells. Based on these criteria, a total of 77 monitoring wells were selected for the Thiessen polygon discretization. These monitoring wells are shown on Figure 5-7 and labeled with name and database ID⁸ in parentheses.

⁶ Specific yield is the amount of groundwater that a unit volume of aquifer will yield when drained by gravity. This is related to the pore space where water occurs between the gravel/sand/silt/clay grains within the aquifer.

⁷ These modeling analyses will be considered for the 5-year report.

⁸ The well database ID can be used to browse the IWV DMS website to view available groundwater data and reports (iwvgs.com).

5.3.2.2 *Estimated Changes to Groundwater in Storage: Spring 2016 to Spring 2023*

Changes to groundwater in storage are estimated each year for the Annual Report and to be used for managing IWV’s water resources. These changes over time are most notable in the areas of the basin where declining groundwater levels are being observed. Though measuring of groundwater levels had been interrupted for a couple of years, Spring 2022’s comprehensive measurements showed a continuing decline in groundwater levels in the IWV basin and in groundwater in storage (Table 5-1). These changes in groundwater levels represent about half of the overall delineated GSA Boundary where there are available groundwater level data and the major pumping occurs.

Table 5-1: Estimated Annual Change to Groundwater in Storage, Spring 2022 to Spring 2023

	Polygon Area (acres)	Spring 2022 to Spring 2023 (AF)
IWV Main Basin	154,960	-12,370
El Paso Subarea	34,010	-5,513
Total Study Area	188,971	-17,883
Total GSA Basin	381,746	<i>n/a</i>
<i>% of GSA Basin</i>	<i>49.5%</i>	<i>not estimated</i>

The annual change of groundwater in storage within the measured study area of the IWB Basin from Spring 2022 to Spring 2023 is estimated to be a loss of 12,370 AF in the IWV main basin and a loss of 5,513 AF in the El Paso Subarea based on changes to groundwater levels at 77 wells. The change in storage estimate will be expanded to account for the whole IWV GSA as data gaps are addressed and the model is updated for the 2025 GSP Plan Amendment.

Figure 5-8 provides a plot of the estimated groundwater storage change from WY 2016 to WY 2023 along with the recent estimated groundwater pumping. See Chapter 6.1 for the discussion of groundwater pumping. The modified Thiessen Polygon method estimates a continued decrease of groundwater in storage for the main IWV Basin, and although there was a decrease of groundwater in storage in the El Paso subarea in WY 2023, there has been an overall increase in groundwater storage in the El Paso subarea where there is very limited domestic pumping (and limited groundwater level data). Sustainable

Management Criteria for monitoring loss of groundwater in storage is measured as a cumulative total since WY 2020 (see Table 5-2).

Table 5-2: WY 2020 to WY 2023 Estimated Groundwater Storage Change, Modified Thiessen Polygon Method

	Thiessen Area (acres)	Average Annual AFY			WY 2023 (AF)	4-Year Cumulative Change (AF)
		WY 2020 (AF)	WY 2021 (AF)	WY 2022 (AF)		
IWV Main Basin	154,960	-15,883	-15,883	-15,883	-12,370	-60,019
El Paso Subarea	34,010	2,390	2,390	2,390	-5,513	1,657
Total	188,971	-13,492	-13,492	-13,492	-17,883	-58,359
<i>Hydrologic Condition</i>		AN	D	BN	W	

Note: Storage Change is based on the measured study area, approximately 49.5% of the 381,746 acres of the Total IWV Basin.

Page Intentionally Left Blank

Chapter 6 Water Supply Data

6.1 Groundwater Extraction Data

Groundwater from the IWVGB is the sole source of potable water in the Indian Wells Valley. Groundwater is produced from approximately 970 wells. Figure 6-1 provides the location of the production wells in the IWVGB⁹. Since 2018, the IWVGA has been actively engaged in efforts to determine annual groundwater production in the IWVGB and improve the accuracy of production estimates. These efforts are summarized below with the years the work was conducted in parenthesis.

- Baseline Pumping Conditions (2018-2019): The most recent available pumping data at the time (2018) were compiled from known and cooperative individual groundwater producers in order to develop the numerical flow model. Through stakeholder outreach efforts, major pumpers provided estimates to use for future conditions (2020 through 2070) that reflected their projected water demands. Prior studies were used to estimate pumping for years 1975-2017 for groundwater producers where little data were available nor provided by stakeholder outreach.
- Well Registration and Reporting (2018-Current): The IWVGA implemented well registration and well production reporting requirements in 2018 for the purpose of collecting volumetric pumping fees. All groundwater producers subject to the fees established by the IWVGA are required to register their groundwater production wells and report monthly groundwater production.
- Sustainable Yield Allocation (2020-Current): The IWVGA requested historical pumping records from all non-*de minimis* pumpers (excluding federal entities) for the purpose of allocating the sustainable yield of the IWVGB. This allocation is used to determine a pumping allotment that is not subject to the Basin Replenishment Fee.
- Flow Meter Requirements (2020): The IWVGA adopted Ordinance 01-20 requiring the installation and testing of IWVGA-approved flow and hour metering equipment on all non-*de minimis* and non-federal wells in the Basin, with the purpose of increasing accuracy of groundwater production records.
- Transient Pool (2020-Current): The IWVGA developed a Transient Pool program (see Section 3.1.1) which requires reporting of groundwater production to the IWVGA. This groundwater production is not subject to certain IWVGA established fees and is accounted for separately than other groundwater production.

⁹ There is insufficient data by well to display the volume of each production well on Figure 6-1; however, the figure shows the location of wells by well use category.

- Legal Action and Settlements (2020 through Current): The IWVGA has taken legal action against non-compliant pumpers and has entered into settlements regarding the payment of fees and reporting of groundwater production.
- Pumping Verification (2023 through Current): In WY 2023, the IWVGA began a review and verification process of all production records for the years 2018 to current to update the numerical model production values. This task will continue into WY 2024.

Despite these efforts, data gaps in groundwater production within the IWVGB still exist. These gaps are partially due to inaccuracies of self-reporting, non-compliant groundwater producers who do not report production data, groundwater producers who have not installed water meters on their wells, and groundwater producers present in the IWVGB that are not subject to reporting (i.e. de minimis extractors). Additionally, current litigation has brought into question the accuracy of some self-reported groundwater production data due to inconsistencies with reported groundwater production and documented and stated water use.

The methods that groundwater producers use to report their production include the following:

- Water meters
- Electrical meters
- Estimates based on land use
- Estimates based on population served by groundwater production well

The best engineering estimate of WY 2023 pumping is derived from the combination of all pumping records and sources available to the IWVGA and is presented in the final column in Table 6-1, below. Attachment G provides a more detailed breakdown of pumping categories and the data source for each value. The IWVGA is continually working to improve its estimate of groundwater production in the IWVGB because these data are critical components of the water budget and essential for managing sustainability.

Table 6-1: IWVGB Groundwater Production Estimates

Water Use Sector	Estimated No Action Projections WY 2023 (AF)	WY 2023 Reported Pumping (incomplete) ³	WY 2023 Total Estimated Pumping (AF) ^{4,5}
Urban	7,050	4,300	5,620
Industrial	2,910	2,510	2,570
Agriculture	22,530 ²	7,700	8,110
Other – Federal ¹	2,040	1,380	1,380
Other – Domestic/ Mutuals/Co-Ops/ Community Services District	1,380	150	1,470
TOTAL	35,910	(incomplete)	19,150

- 1 Federal groundwater use is for NAWWS China Lake and are provided by the U.S. Navy. Federal entities are not required to report monthly production to the IWVGA for the purpose of paying fees established by the IWVGA; however, though not required, the U.S Navy provided monthly production to the IWVGA for the Annual Report.
- 2 This value includes planned agricultural projections provided by pumpers and probably overestimates future agricultural groundwater production.
- 3 These values underestimate actual groundwater production in WY 2023 because not all non-de minimis groundwater producers submit data regularly to the IWVGA and because *De minimis* users (those that produce less than 2 acre-feet per year (AFY) or those that have four or fewer connections) are not required to report monthly production to the IWVGA for the purpose of paying fees established by the IWVGA.
- 4 See Attachment G for a more detailed table.
- 5 Actual pumping may be higher than estimated.

Table 6-2 below shows annual groundwater production estimates. Groundwater production within the IWVGB has been estimated to decrease since WY 2019 (the first year an Annual Report was prepared). This is due to the implementation of projects and management actions. The decrease in production that occurred in WY 2023 could also be due to the increased precipitation that year. In WY 2023, the estimated total groundwater production was 2.5 times the estimated sustainable yield of 7,650 indicating overdraft conditions have continued in the IWV.

Table 6-2: Total Estimated Pumping by Water Year

Water Year	Total Estimated Pumping (AF)
WY 2019	22,800
WY 2020	21,990
WY 2021	20,800
WY 2022	21,160
WY 2023	19,150

6.2 Surface Water Supply

Natural surface waters are not used as a drinking water supply source in the IWVGB. Approximately 2,540 acre-feet of recycled water was produced at the City of Ridgecrest’s wastewater treatment plant during WY 2023 and was used for the following:

- Landscape irrigation (golf course)
- Agricultural irrigation (alfalfa)
- Partial maintenance of the Mojave Tui Chub habitat (environmental water)
- Discharge to evaporation/percolation ponds

Table 6-3 below provides the estimated breakdown of beneficial recycled water use in WY 2023.

Table 6-3: WY 2023 Recycled Water Use.

Recycled Water Use Sector	WY 2023 Estimated Use¹ (AF)
Urban ²	270
Agriculture ³	200
Other ⁴	830
TOTAL	1,300

¹ Data provided in email by the City of Ridgecrest to Stetson Engineers Inc on October 18, 2023.

² Used for irrigation of golf course on NAWs China Lake.

- 3 Used for irrigation of alfalfa fields for beneficial re-use.
- 4 Recycled water not used for urban and agricultural irrigation is disposed of in evaporation/percolation ponds. Approximately 2,060 AF was discharged to the ponds in WY 2023. It is estimated approximately 60 percent of the recycled water discharged to the ponds evaporates, with the remaining 830 AF percolating to the groundwater (Provost and Pritchard Consulting Group, 2015). In addition, these ponds partially support the Mojave Tui Chub habitat on NAWs China Lake.

6.3 Total Water Use

Total water use in the IWVGB during WY 2023 is comprised of groundwater supplies and recycled water supplies. See Chapters 6.1 and 6.2 above for additional detail on these supplies.

Table 6-4: WY 2023 Estimated Total Water Use in the IWVGB.

Use Category	WY 2023 Estimated Total
	Water Use (AF)
Groundwater Production	19,150
Recycled Water	1,300
TOTAL	20,450

Page Intentionally Left Blank

Chapter 7 Other Data Collection and Basin Management Tasks

In WY 2023, the IWVGA has continued its data collection efforts and basin management tasks to improve Basin understanding and monitor groundwater sustainability, in addition to the regular groundwater level monitoring discussed in Chapter 5. These efforts help address the data gaps outlined in the GSP and are listed below:

- Data gaps associated with groundwater monitoring in the El Paso subarea
- Data gaps associated with streamflow and mountain front recharge
- Data gaps associated with the subsurface flow from Rose Valley into IWVGB
- Data gaps associated with the subsurface flow out of IWVGB to Salt Wells Valley
- Data gaps associated with groundwater dependent ecosystems (GDEs)
- Data gaps associated with aquifer properties

Summaries of key tasks are provided below.

7.1 Annual Groundwater Quality Sampling

Twenty-four groundwater quality samples were collected and sent to a laboratory for analysis in October 2022 from twenty monitoring wells and 4 domestic wells within the IWVGB. The purpose of this annual sampling was to obtain representative data to compare to the interim milestones for the sustainable management criteria, augment data in the existing water quality database, and address some data gaps for sustainable management of the IWVGB. Results from this sampling, provided in Attachment H, will be used to refine the existing IWVGB monitoring network (GSP § 354.34), validate the hydrogeologic conceptual model (HCM) (GSP § 354.14), and update the numerical groundwater model (GSP § 354.16) for the 2025 GSP Evaluation.

7.1.1 TDS Results

Salinity, represented by total dissolved solids (TDS), is one of two main groundwater quality constituents of concern in the IWVGB. The lowest observed TDS concentration collected in Fall 2022 was 160 mg/L at monitoring well AB303-05 (952-955 feet depth) and at monitoring well AB303-03 (497-500 feet depth) in the El Paso Subarea. The highest observed TDS concentration collected in Fall 2022 was 19,000 mg/L (572-

575 feet depth) from the deep screen interval of monitoring well 26S/39E-05K01 near the southwest fence line on the Navy Base.

The areal distribution of TDS concentrations from the October 2022 sampling event are displayed on Figure 7-1. Five of the twenty-four wells sampled had TDS concentrations equal to or greater than 1,000 mg/L: 26S/39E-05L01(S) and 26S/39E-05K01(D) near the southwestern Navy fence line, 26S/40E-22E1 and -22E2 near Navy administration buildings, and 27S/40E-01K02 (George Air Corridor) east of Ridgecrest. TDS concentrations above the Secondary Maximum Contaminant Level (SMCL) (500 mg/L) were also present in the northwest, while lower TDS concentrations (<500 mg/L) occurred in the El Paso subarea and along the Sierra Nevada Mountain front. Results from the October 2022 water quality samples are consistent with historical data presented in the January 2020 GSP.

Historical TDS trends are plotted in Figure 7-2 for 11 wells with three or more TDS measurements. TDS results at IWVGB monitoring wells are summarized below.

- Monitoring well 25S/38E-03B is located in the northwest of IWV basin near U.S. Highway 395 by Pearsonville and is screened from 300 to 360 feet below ground surface (bgs). Five TDS samples have been collected from 2007 to 2022. The TDS concentration taken in Fall 2022 was 580 mg/L. This was a decrease of 10 mg/L from Fall 2021 (570 mg/L).
- Domestic well 25S/38E-14A is located in the northwest of IWV basin, southeast of well 03B. Four TDS samples have been collected from 2019 to 2022. TDS concentrations at 25S/38E-14A ranged from 400 mg/L (2020) to 450 mg/L (2021), and then decreased to 430 mg/L in October 2022.
- Domestic well 25S/38E-34A01 is also located in the northwest of IWV near U.S. Highway 395 directly south of 03B. This well is screened from 418.5 to 478.5 ft bgs. Five TDS samples have been collected from this well from 2006 to 2022 with TDS concentrations ranging from 260 mg/L (2006) to 530 mg/L (2019). TDS in 25S/38E-34A01 increased 70 mg/L from 2021 (450 mg/L) to 2022 (520 mg/L).
- Navy monitoring well 25S/39E-03R01 (Baker Range) is located on the northern range of the Navy base, and is screened from 65 to 165 ft bgs. Four TDS samples have been collected from this well from 2019 to 2022. TDS concentrations range from 660 mg/L (2019) to 590 mg/L (2021). TDS in the Baker Range well increased 20 mg/L from 2021 (590 mg/L) to 2022 (610 mg/L).
- Navy monitoring well 25S/39E-12R (Charley Tower) is located near the northern playa on NAWS China Lake. This well is screened from 60 to 140 ft bgs. Twenty-six TDS samples have been

collected from this well from 1953 to 2022. TDS concentrations range from 650 mg/L (July 1978) to 780 mg/L (October 1961). The 2022 TDS concentration of 690 mg/L was a decrease of 30 mg/L from the previous year.

- Domestic well 26S/38E-01M05 is located north of Inyokern. This well is screened from 299 to 359 ft bgs. Water quality samples have been collected from this well during the last three annual sampling events and ranged from 520 mg/L (November 2020) to 570 mg/L (October 2021). The 2022 TDS concentration at 26S/38E-01M05 was measured at 530 mg/L showing a decrease in concentration of 40 mg/L from the previous year.
- Monitoring well 27S/38E-13A02 (AB303-01) is located in the southwest area of the IWVGB just south of Bowman Road and east of Red Rock Canyon Road. This well is screened from 232 to 272 ft bgs, 372 to 472 ft bgs, and 632 to 690 ft bgs. Two TDS samples were collected from this well in 2007 and 2021. TDS concentrations range from 300 mg/L (August 2007) to 340 mg/L (October 2021). The 2022 TDS sample was collected from the mid-level screen with a concentration of 300 mg/L.
- Navy monitoring well 27S/40E-01K02 (George Air Corridor) is east of Ridgecrest on Navy property. This well is screened from 320 to 380 ft bgs. Five TDS samples have been collected from this well from 1953 to 2022. TDS concentrations range from 1,000 mg/L (October 2022) to 1,510 mg/L (June 1972). The 2022 TDS concentration was measured at 1,000 mg/L showing a decrease in concentration of 200 mg/L from the previous year.

El Paso Subarea Monitoring Wells

- Monitoring well 27S/38E-09C01 (AB303-04) is located in the El Paso subarea of the IWVGB near Highway 14. This well is screened from 501 to 581 ft bgs. Four TDS samples have been collected from this well from 2007 to 2022. TDS concentrations range from 290 mg/L (November 2020) to 460 mg/L (August 2007). The current TDS concentration was measured at 290 mg/L, a decrease in concentration of 60 mg/L from 2021 to 2022.
- Monitoring well 27S/38E-21L01 (AB303-05) is located in the El Paso subarea and screened from 905 to 1,005 ft bgs. Five TDS samples have been collected from this well from 2007 to 2022. TDS concentrations range from 160 mg/L (November 2020) to 510 mg/L (August 2007). The 2022 TDS concentration was measured at 160 mg/L, a decrease in concentration of 40 mg/L from 2021 to 2022.

7.1.2 Arsenic Results

Arsenic is the other defined contaminant of concern in the IWVGB. The maximum contaminate level for arsenic in drinking water is 10 µg/L. Figure 7-3 shows the areal distribution of arsenic in groundwater

concentrations from October 2022. The lowest observed arsenic concentrations collected during October 2022 was 1.3 µg/L observed in wells AB303-01 (397-400 ft bgs) and AB303-04 (557-560 ft bgs). The highest observed arsenic concentration was 330 µg/L at Navy monitoring well 26S/40E-22E02 (557-600 ft bgs). These samples will provide a baseline for future arsenic samples collected.

7.2 Los Angeles Department of Water and Power Water Releases

In March 2023, the Los Angeles Department of Water and Power (LADWP) began releasing water from the Los Angeles Aqueduct into the Indian Wells Valley at the following locations: Freeman Wash, Boulder Draw, Indian Wells, Sage Canyon, and Bird Springs. Flow paths indicate that released water from Boulder Draw and Indian Wells Canyon flows into northern IWV stream channels, while water released from Freeman Wash, Sage Canyon and Bird Springs flows into the El Paso subarea. During the Spring 2023 water level measurement, seven (7) dataloggers at monitoring wells along potential flow paths were installed to measure groundwater level changes. In addition, water quality samples of the released water were collected. A report presenting the collected data will be released in WY 2024.

7.3 Rose Valley Subsurface Flow Monitoring and Evaluation

Permitting with the United States Bureau of Land Management (BLM), California State Lands (CSL), and Inyo County was completed during WY 2022 for drilling two new monitoring wells and evaluating a capped former sawmill well south of Little Lake. Drilling of RVS-MID was funded by a Cooperative Agreement with the U.S. Navy. The well was installed in Spring 2023. Since July 6, 2023, a datalogger has been installed in RVS-MID and two manual measurements have been taken. In WY 2023, permitting was pursued for an alternative well site for the second Rose Valley subsurface flow monitoring well. This well is anticipated to be drilled in WY 2024. Groundwater levels from these wells will be used to fill a data gap for estimating subsurface flow from Rose Valley into Indian Wells Valley. In WY 2023, a draft report was prepared to summarize the results of a hydrogeologic analysis of the Rose Valley groundwater Basin and an estimate of the underflow from Rose Valley Groundwater Basin into the IWVGB. This report will be finalized in WY 2024.

7.4 El Paso Monitoring and Evaluation

On January 26, 2021, the IWVGA entered into an agreement with DWR for Technical Support Services to drill and construct one triple-nested monitoring well (EP-01) in the El Paso Subbasin. The well and monitoring equipment was installed in WY 2021. Beginning in 2021, the IWVGA has monitored EP-01 and maintained the data records consistent with other groundwater monitoring program wells; reporting EP-01 groundwater levels to the DMS as well as uploading this data to the DWR SGMA data portal. The IWVGA has continued to work with DWR to obtain telemetry equipment for this well in 2023. This monitoring well is important for filling in groundwater level data gaps in the El Paso Subbasin and defining hydrogeologic characteristics in the Basin.

In WY 2023, a draft report reviewing the hydrogeologic features and groundwater chemistry of the El Paso Subarea was prepared. This report will be finalized in WY 2024.

7.5 Brackish Water Investigation

Brackish water groundwater resources in the IWV have been the subject of ongoing study by the IWVWD and funding partners for several years with the goal of determining feasibility of developing brackish resources as an alternative water supply.

In WY 2023, work continued on preparing the first phase of the Feasibility Study to be submitted to DWR in WY 2024. Most of the brackish water in the IWVGB is believed to be underlying federal property at NAWS China Lake. To date, the U.S. Navy has not permitted drilling or sampling of brackish water on NAWS China Lake in conjunction with this Feasibility Study. Consequently, additional project phases are unlikely to be pursued by the IWVWD.

7.6 Numerical Model

The numerical groundwater model developed for the Indian Wells Valley (IWV) Groundwater Sustainability Plan (GSP), GSP Model, is the primary tool used by the IWVGA TAC and Staff to quantify the occurrence and movement of groundwater, and to develop planning scenarios for managing the water resources of the IWVGB. In 2021, a Configuration Management Plan (CMP) was developed for determining the process of technical review of new data, making recommendations to the GA Board for model updates, and documenting any model revisions. A key component of this plan is the establishment of a

Technical Modeling Group (TMG). At the end of 2022, the TMG prepared a list of groundwater model configuration items (CIs) that was recommended to the GA Board for model updates.

The TMG conducted 25 meetings to implement the Configuration Management Plan during WY 2023. These meetings are summarized in Attachment I. Tasks and subtasks completed in WY 2023 include:

- Task 1 Model Domain Boundary
 - Subtask 1a. Define base of model domain
 - Subtask 1b. Define aerial extent of groundwater basin boundary
- Task 2 Hydrogeologic Conceptual Model
 - Subtask 2a. Inclusion of faults
 - Subtask 2b. Hydrogeologic framework
 - Subtask 2c. Aquifer properties
- Task 3 Hydrologic Budget
 - Subtask 3a. Spatial distribution of mountain-front recharge
 - Subtask 3b. Spatial distribution of bare soil evaporation and evapotranspiration

This work will be used as part of the GSP Plan Amendment in 2025.

7.7 Data Management System

The IWVGA maintains a data management system (DMS) to support SGMA implementation. The SGMA regulations require having a DMS to support a GSA. This DMS consists of both a database part to store data and a public website to present data. Examples of stored data include monitoring data, management criteria, and other supporting documentation. Server logs show the public have been accessing and using DMS. IWVGA has used the DMS website to help inform meetings and improve basin management.

As a software system, operation of the DMS requires periodic maintenance and updates. During WY 2023, IWVGSP spent funding and time to update databases, as well as update software. Database updates included the addition of new groundwater and surface water monitoring data. Other work included more review of existing entries for accuracy. Software updates included security updates and functionality improvements. Additional updates to the DMS will be made, as necessary, to address DWR's RCAs.

7.8 Precipitation Station and Stream Gage Data Collection

The IWVGA collects precipitation and stream flow data from precipitation stations and stream gages installed throughout the IWW. In 2020 IWVGA installed two precipitation stations and two stream gage stations to augment historical and current monitoring location data. During WY 2023, the IWVGA continued to operate these stations and gages, utilizing telemetry to transmit provisional data to the DMS. Various issues were encountered during WY 2023 including issues with flooding and issues with damage and theft of equipment. Data records are posted to the DMS annually concurrent with this Report, and presented in the summary reports in Attachment J.

Various data sets will be used to refine the existing IWW groundwater basin monitoring network (GSP § 354.34), validate the hydrogeologic conceptual model (HCM) (GSP § 354.14), and update the numerical groundwater model (GSP § 354.16) for the GSP Plan Amendment in 2025.

7.9 Groundwater Dependent Ecosystems

Three¹⁰ groundwater dependent ecosystem (GDE) sites were identified by a Navy biologist based on vegetation type during WY 2022. The GDE monitoring program will evolve through the next few years as data are collected and more vegetation surveys are completed. In WY 2023, the U.S. Navy conducted biological surveys at GDE monitoring sites. A report on these surveys is anticipated for WY 2024.

¹⁰ Nine potential groundwater dependent ecosystem (GDE) sites were investigated during August 11, 2021 and June/July 2022 field visits.

Page Intentionally Left Blank

Chapter 8 References

- Angster, S.J., Sherrod, B., Barnett, E., Bretthauer, J.L., and Anderson, M.L., 2020, 2020 Update to the Quaternary Fault and Fold Database for Washington State: U.S. Geological Survey data release, <https://doi.org/10.5066/P9X2RR2T>.
- California Code of Regulations (CCR). Title 23, Division 2. Chapter 1.5. Sections 351 and 356.2.
- California Geological Survey (CGS). 2010. Fault activity map of California
<https://www.conservation.ca.gov/cgs/publications/fam>
- Department of Water Resources (DWR). 2016. Water Budget Best Management Practice.
https://water.ca.gov/LegacyFiles/groundwater/sgm/pdfs/BMP_Water_Budget_Final_2016-12-23.pdf December 2016.
- Department of Water Resources (DWR). 2023a. A Guide to Annual Reports, Periodic Evaluations, and Plan Amendments.
- Department of Water Resources (DWR). 2023b. SGMA Data Viewer. Accessed December 5, 2023.
<https://sgma.water.ca.gov/webgis/?appid=SGMADataViewer#landsub>
- Dunne, Thomas, and Luna Leopold, 1978. Water in Environmental Planning.
- Dutcher L.C. and W.R. Moyle, 1973. Geologic and Hydrologic Features of Indian Wells Valley, California. USGS Water Supply Paper 2007. Prepared in cooperation with the California Department of Water Resources.
- Kunkel, Fred and G.H. Chase, 1969. *Geology and Ground Water in Indian Wells Valley, California*. USGS Open-File Report 69-329. Prepared in cooperation with the Naval Weapons Center, China Lake, California.
- Ponti, D.J., Blair, J.L., Rosa, C.M., Thomas, K., Pickering, A.J., Dawson, T. E., compilers, 2020, Digital datasets documenting surface fault rupture and ground deformation features produced by the Ridgecrest M6.4 and M7.1 earthquake sequence of July 4 and 5, 2019: U.S. Geological Survey data release, <https://doi.org/10.5066/P9BZ5IJ9>.
- Provost & Pritchard, 2015. Wastewater Treatment Plant Facility Plan. Prepared for the City of Ridgecrest. October 2015.
- Stetson Engineers Inc, 2020a. *Indian Wells Valley Groundwater Authority; Groundwater Sustainability Plan for the Indian Wells Valley Groundwater Basin*, Bulletin 118 Basin No. 6-054.
- Stetson Engineers Inc., 2020b. Indian Wells Valley Groundwater Basin GSP Annual Report Water Year 2019, May 2020.
- Stetson Engineers Inc., 2021. Indian Wells Valley Groundwater Basin GSP Annual Report Water Year 2020, April 2021.
- Stetson Engineers Inc., 2022. Indian Wells Valley Groundwater Basin GSP Annual Report Water Year 2021, March 2022.

- Stetson Engineers Inc., 2023. Indian Wells Valley Groundwater Basin GSP Annual Report Water Year 2022, March 2023.
- Thiessen, A.H., 1911. Precipitation for large areas, Monthly Weather Review, 39, 1082–1084.
- Tre Altamira Inc, 2023. InSAR Land Surveying and Mapping Services to DWR Supporting SGMA – October 2023 Update. November 2023.
- United States Geological Survey (USGS). 2021. Areas of Land Subsidence in California. Accessed December 15, 2021. http://ca.water.usgs.gov/land_subsidence/california-subsidence-areas.html
- USGS. 2020. Quaternary fault and fold database
<https://www.sciencebase.gov/catalog/item/589097b1e4b072a7ac0cae23>
- USGS. 2019. Surface fault rupture mapping
<https://www.sciencebase.gov/catalog/item/5d699da6e4b0c4f70cf2f936>
- Western Regional Climate Center (WRCC). 2018. 1971 – 2000 Climate Normals for Stations 041733 (China Lake NAF), 044278 (Inyokern), 049035 (Trona), 043710 (Haiwee), 047253 (Randsburg), and 044232 (Independence). Accessed at:
https://wrcc.dri.edu/Climate/west_coop_summaries.php, December 5, 2018.
- Western Regional Climate Center (WRCC). 2020. Period of Record Monthly Climate Summary for Cooperative Stations 041733 (China Lake NAF), 044278 (Inyokern), 049035 (Trona), 043710 (Haiwee). Accessed at: https://wrcc.dri.edu/Climate/west_coop_summaries.php, April 6, 2020.

FIGURES

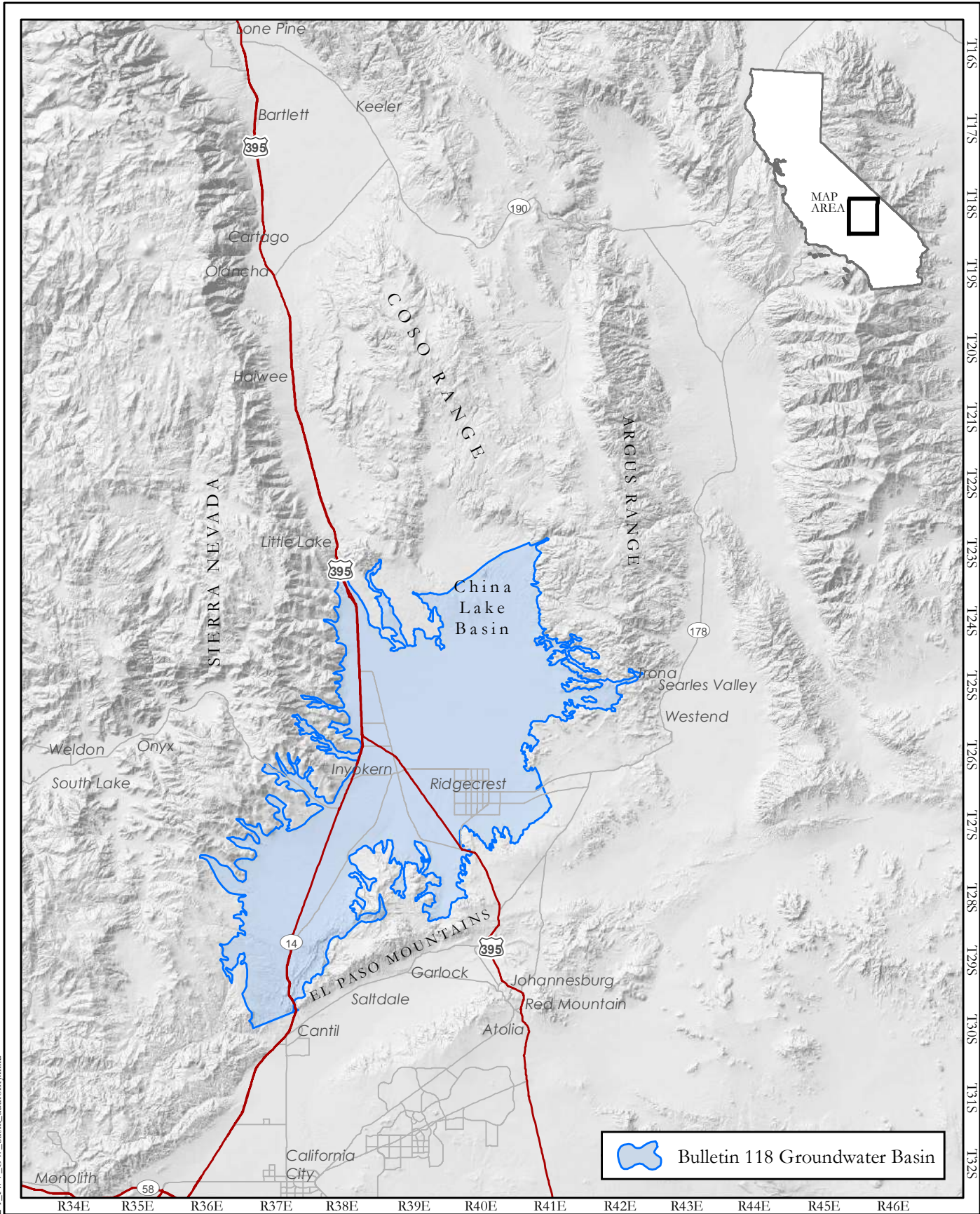

Document Path: F:\jnp2652\Fig2-1_IWV_GW_basin_authorfv.mxd





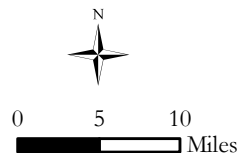

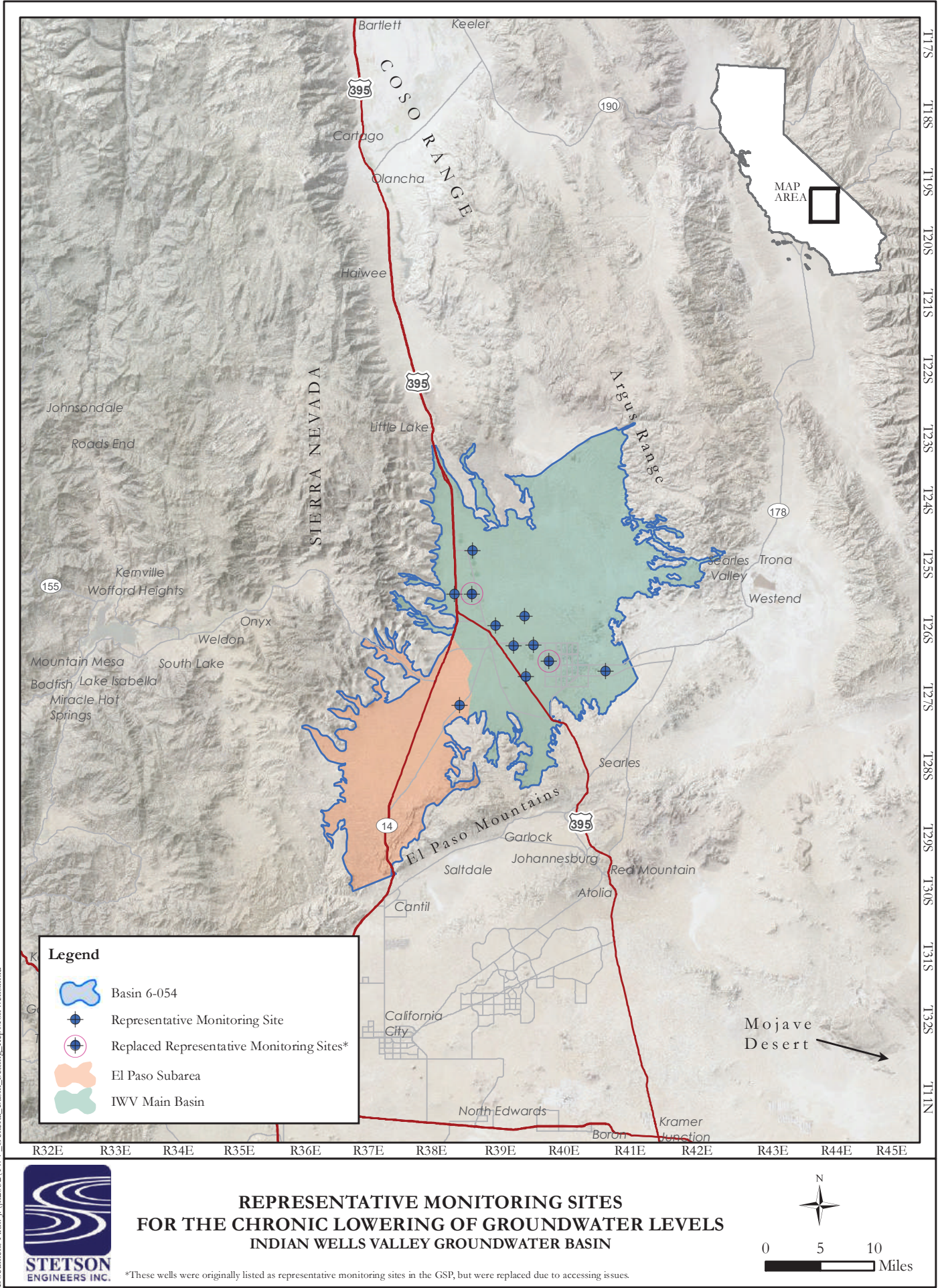
INDIAN WELLS VALLEY GROUNDWATER BASIN AND
INDIAN WELLS VALLEY
GROUNDWATER AUTHORITY BOUNDARIES
 (DWR BULLETIN 118 BASIN NO. 6-054)





Legend

-  Basin 6-054
-  Representative Monitoring Site
-  Replaced Representative Monitoring Sites*
-  El Paso Subarea
-  IWV Main Basin

**REPRESENTATIVE MONITORING SITES
FOR THE CHRONIC LOWERING OF GROUNDWATER LEVELS
INDIAN WELLS VALLEY GROUNDWATER BASIN**

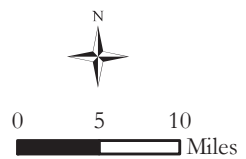

*These wells were originally listed as representative monitoring sites in the GSP, but were replaced due to accessing issues.

Document Path: F:\jpn2652\IWV - General_Basin_Setting_RepMonWells.mxd

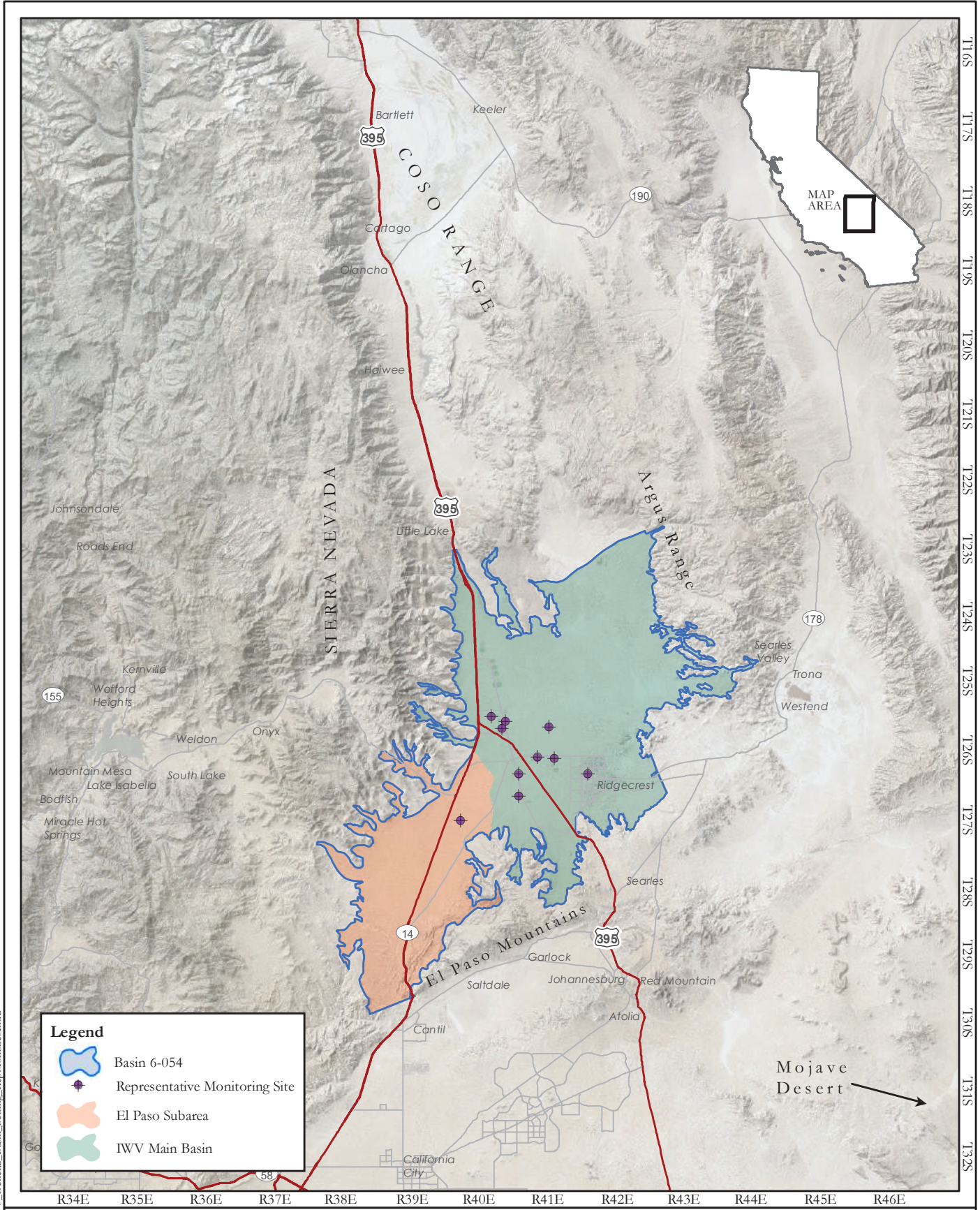

Document Path: I:\jw2652\IWV_General_Basin_Setting_Rep\MonSites.mxd



**WATER QUALITY DEGRADATION,
REPRESENTATIVE MONITORING SITES
INDIAN WELLS VALLEY**

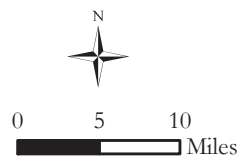

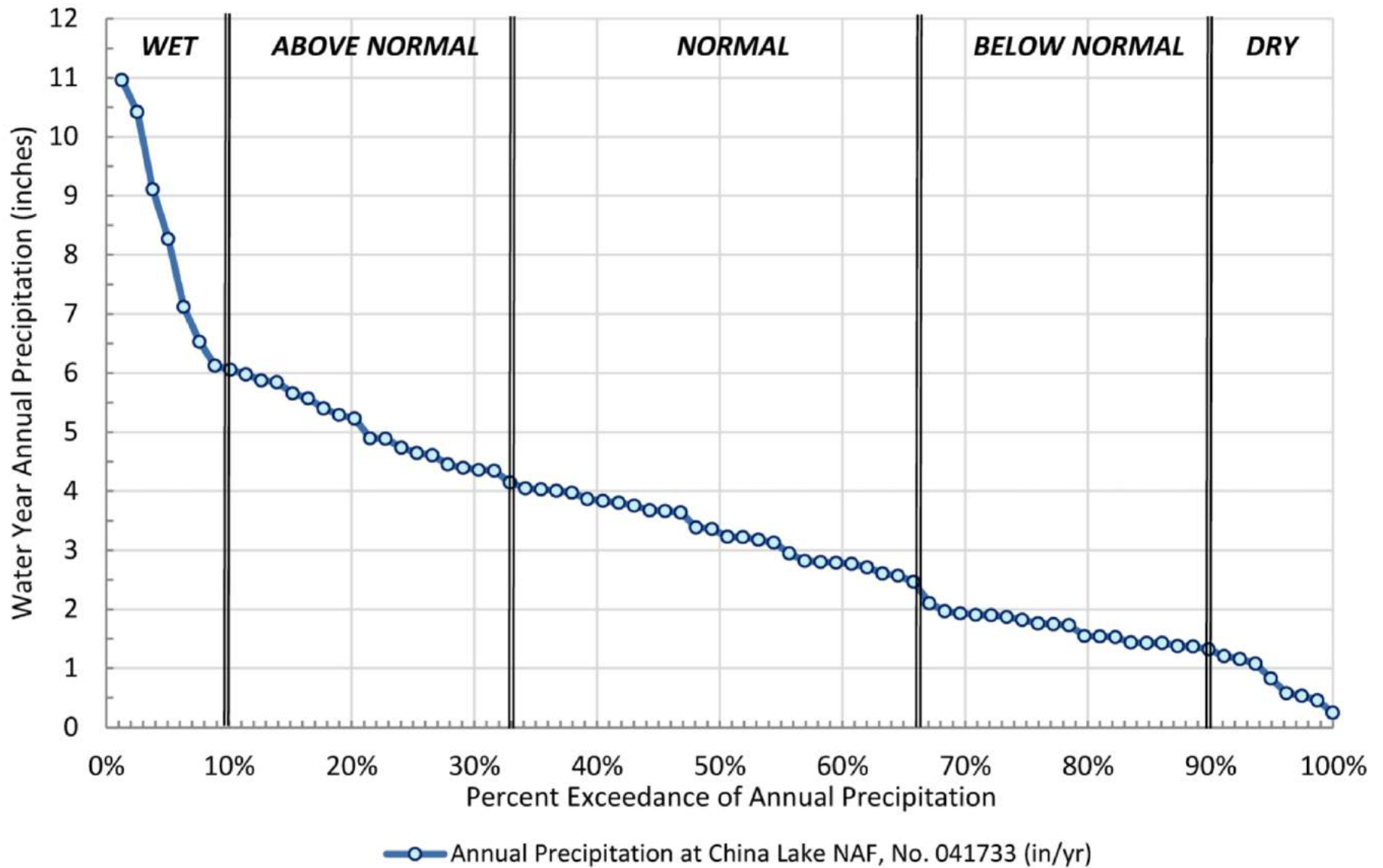

**ANNUAL PRECIPITATION EXCEEDANCE IN IWVGB
HYDROLOGIC INDEX WATER YEARS 1945-2023
INDIAN WELLS VALLEY, CA**

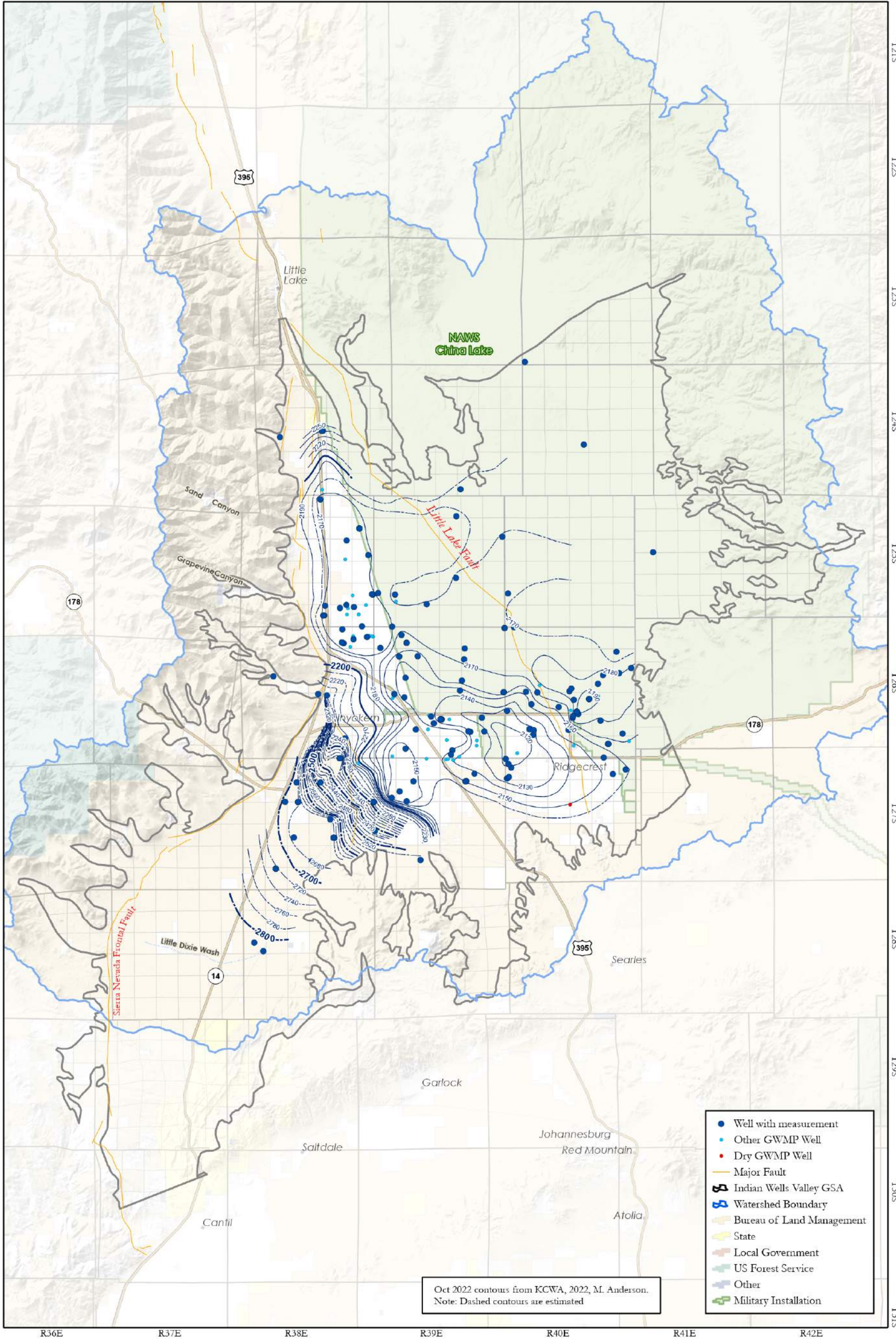

ESTIMATED OCTOBER 2022 GROUNDWATER ELEVATION CONTOURS INDIAN WELLS VALLEY

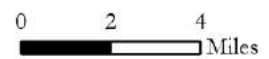

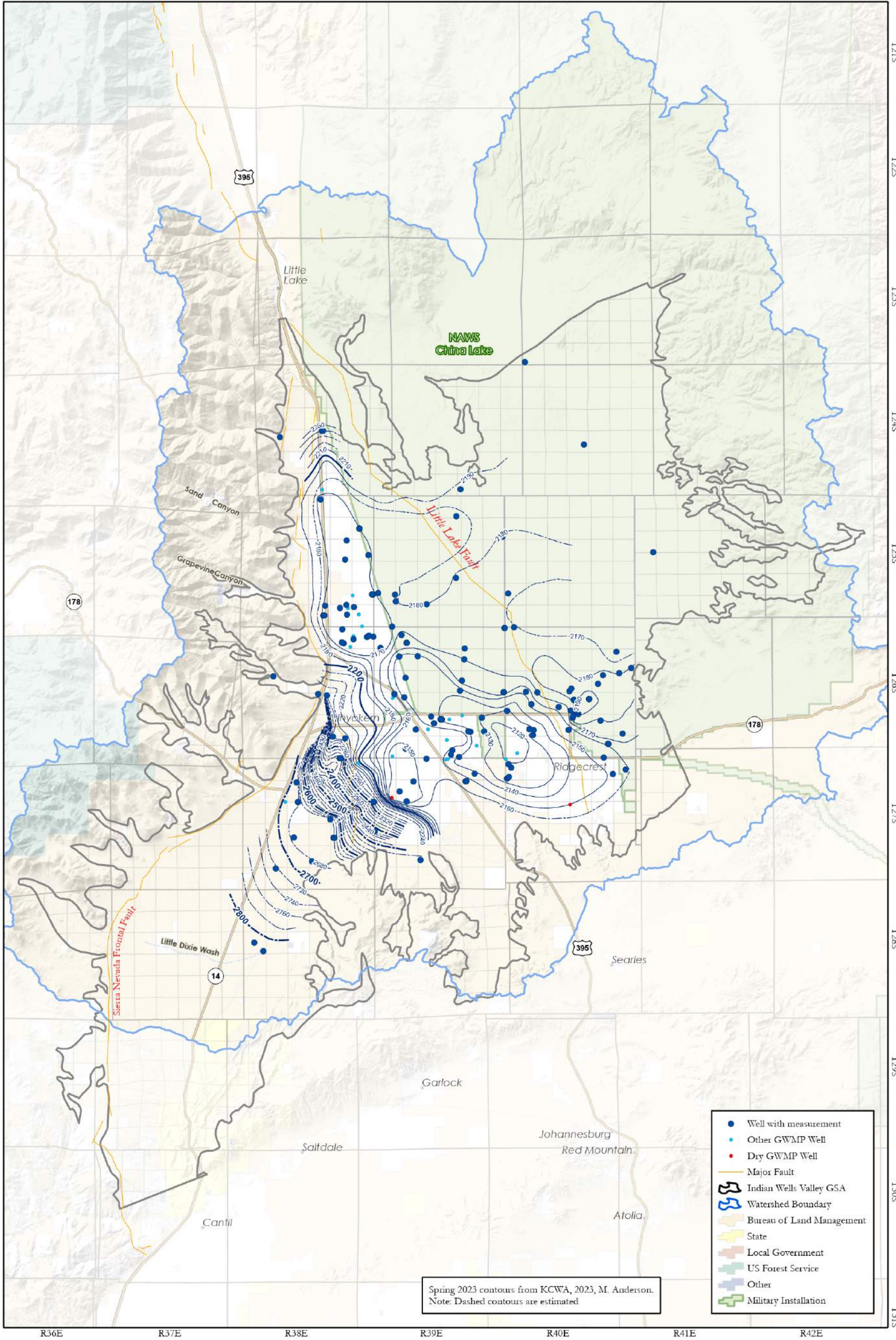

**ESTIMATED SPRING 2023
GROUNDWATER ELEVATION CONTOURS
INDIAN WELLS VALLEY**

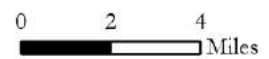

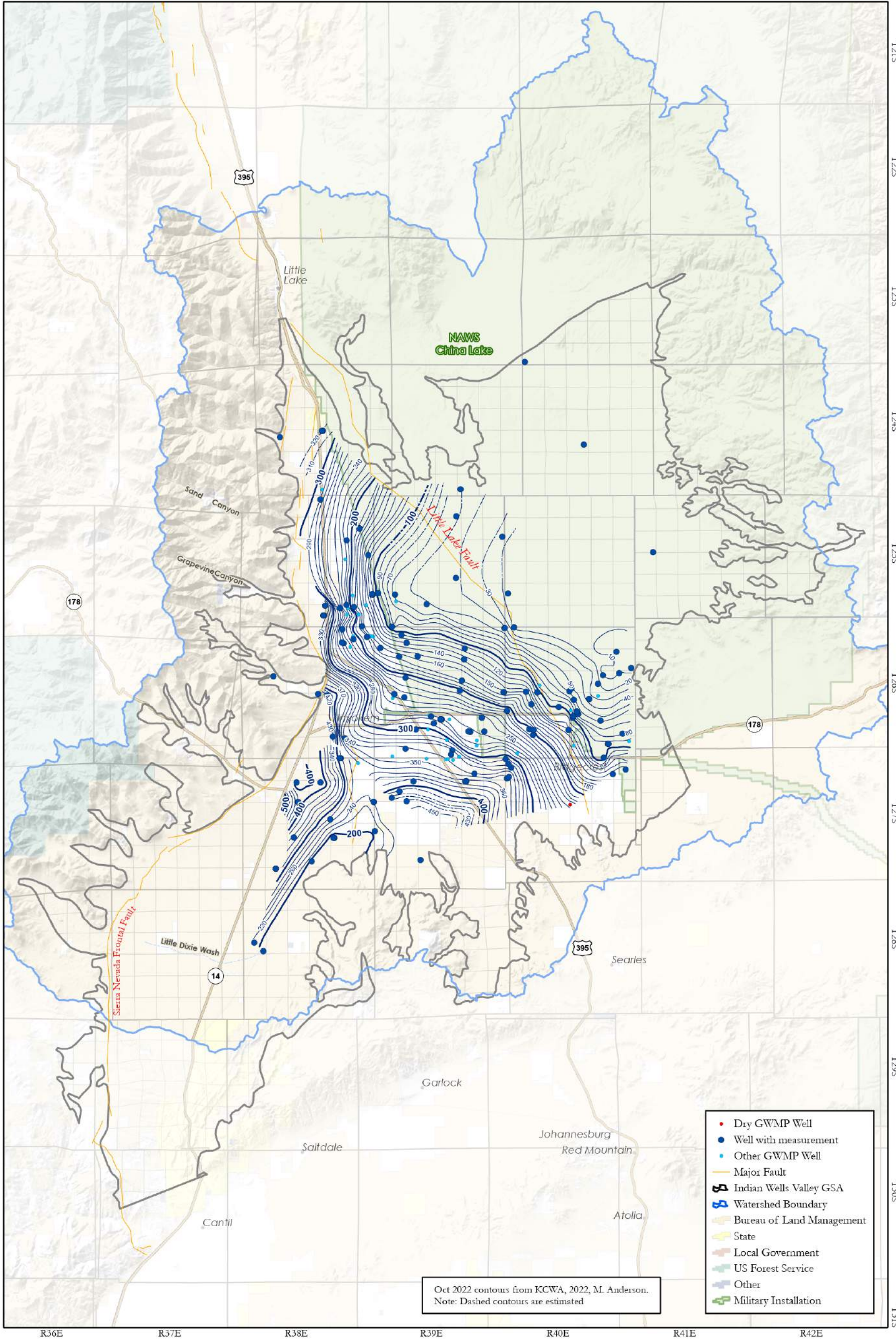

ESTIMATED FALL 2022 GROUNDWATER DEPTH CONTOURS INDIAN WELLS VALLEY

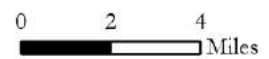

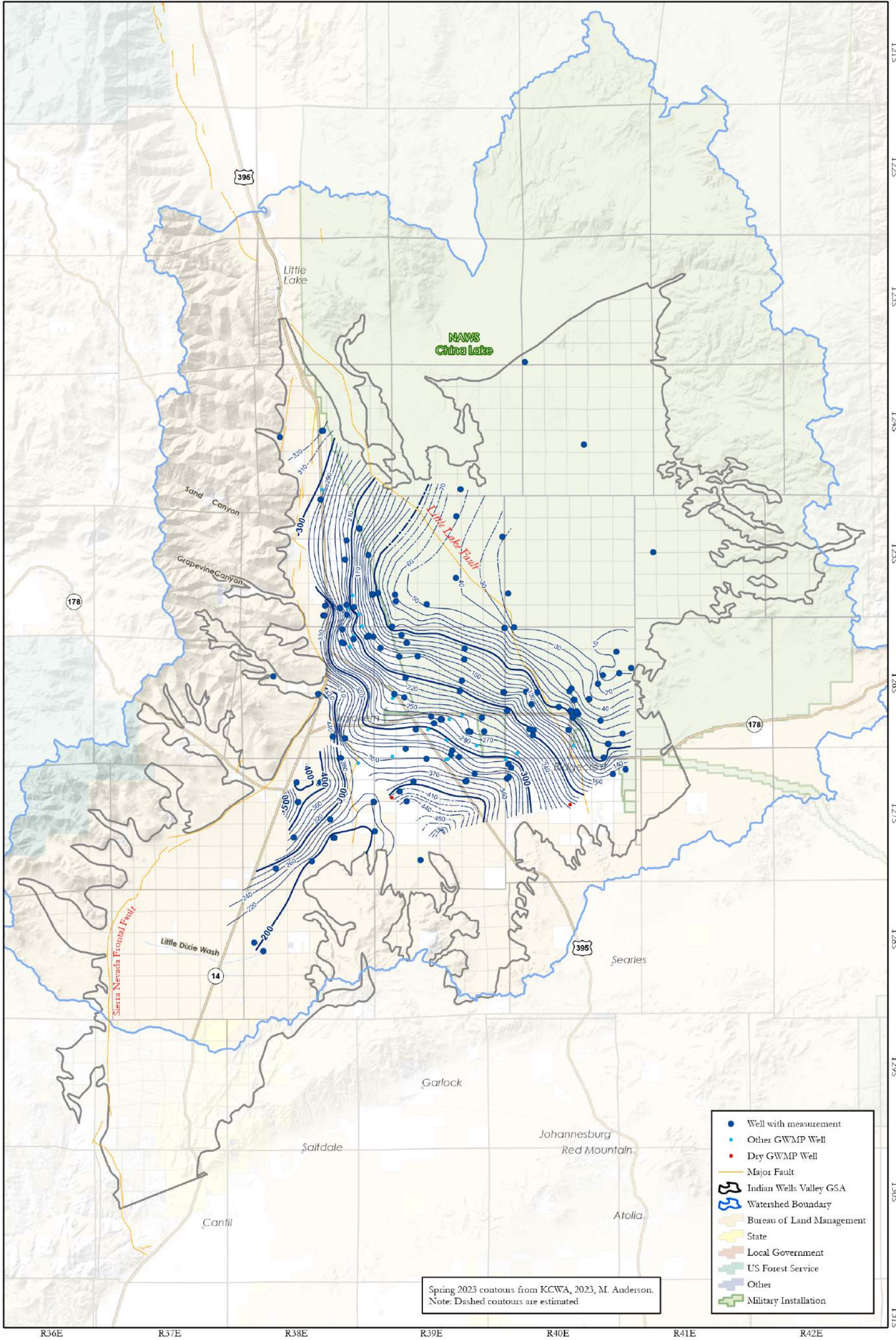

Spring 2023 contours from KCWA, 2023, M. Anderson.
 Note: Dashed contours are estimated

- Well with measurement
- Other GWMP Well
- Dry GWMP Well
- Major Fault
- Indian Wells Valley GSA
- Watershed Boundary
- Bureau of Land Management
- State
- Local Government
- US Forest Service
- Other
- Military Installation



**ESTIMATED SPRING 2023
 GROUNDWATER DEPTH TO WATER CONTOURS
 INDIAN WELLS VALLEY**



FIGURE 5-4

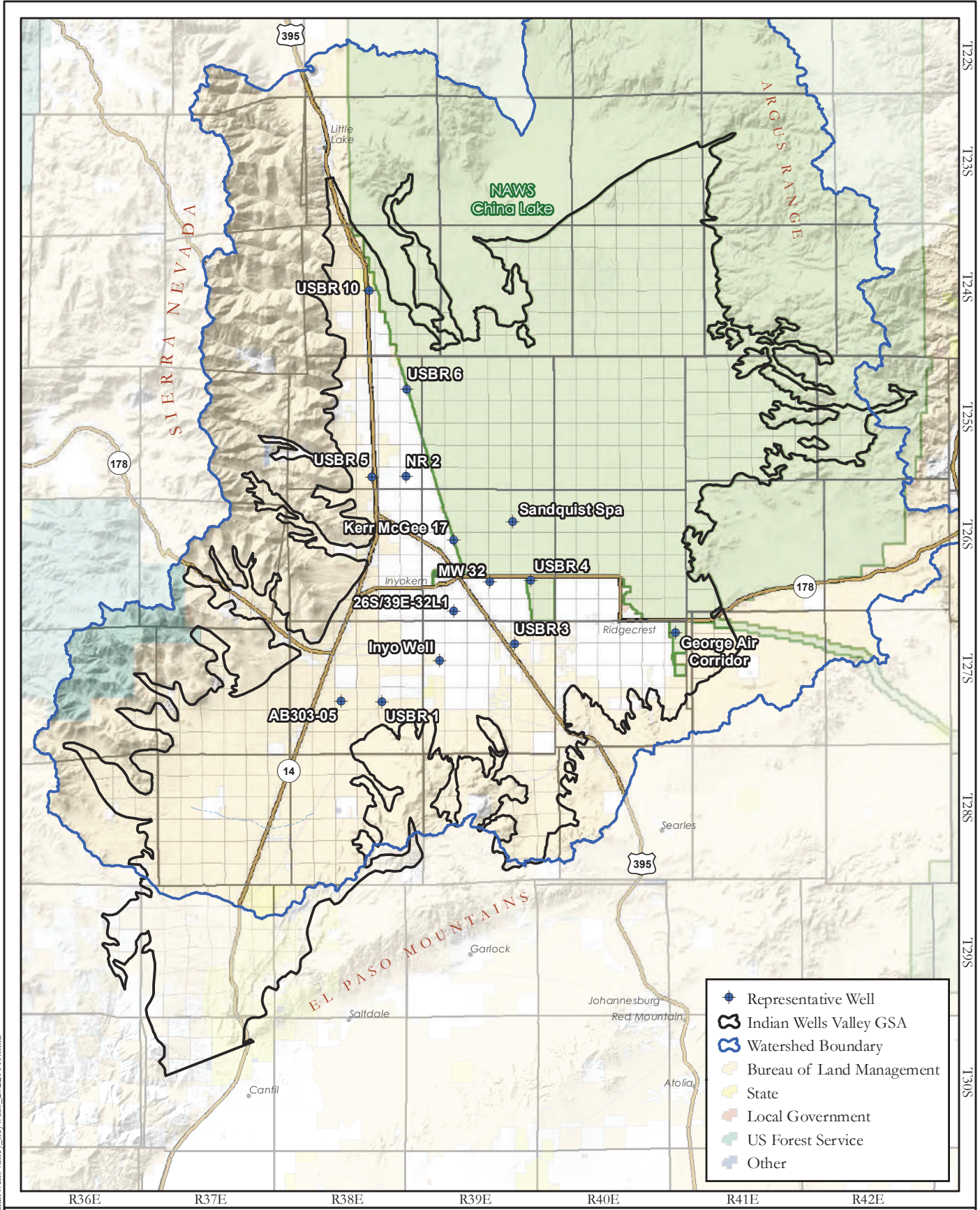

Document Path: F:\jnp2652\IndianWellsValley_keywells_20221111.mxd



**MONITORING WELLS
WITH HYDROGRAPHS IN ATTACHMENT E
INDIAN WELLS VALLEY, CA**

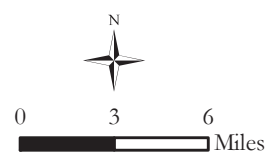

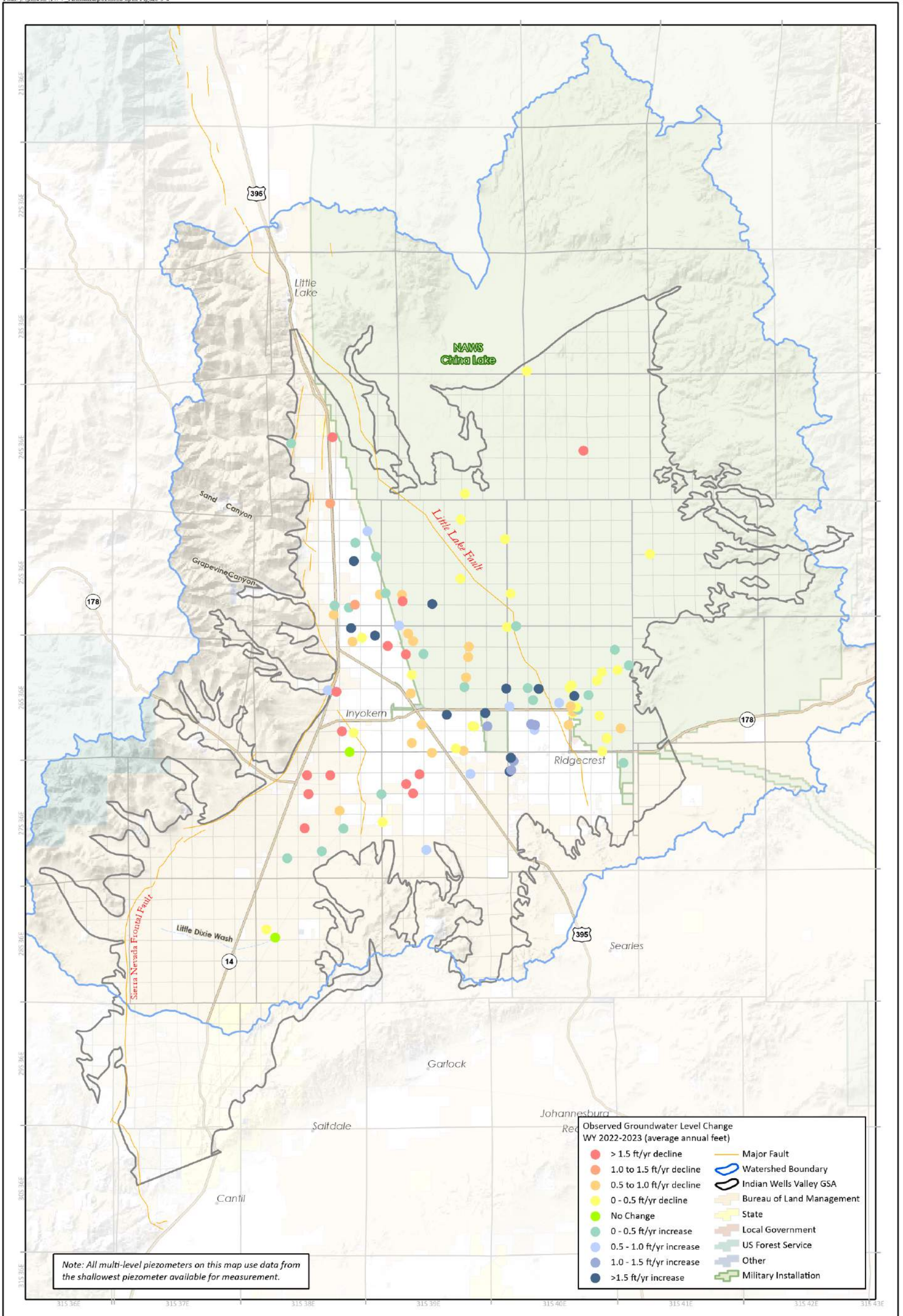

**AVERAGE ANNUAL
GROUNDWATER LEVEL CHANGE
WY 2022 TO 2023
INDIAN WELLS VALLEY, CA**



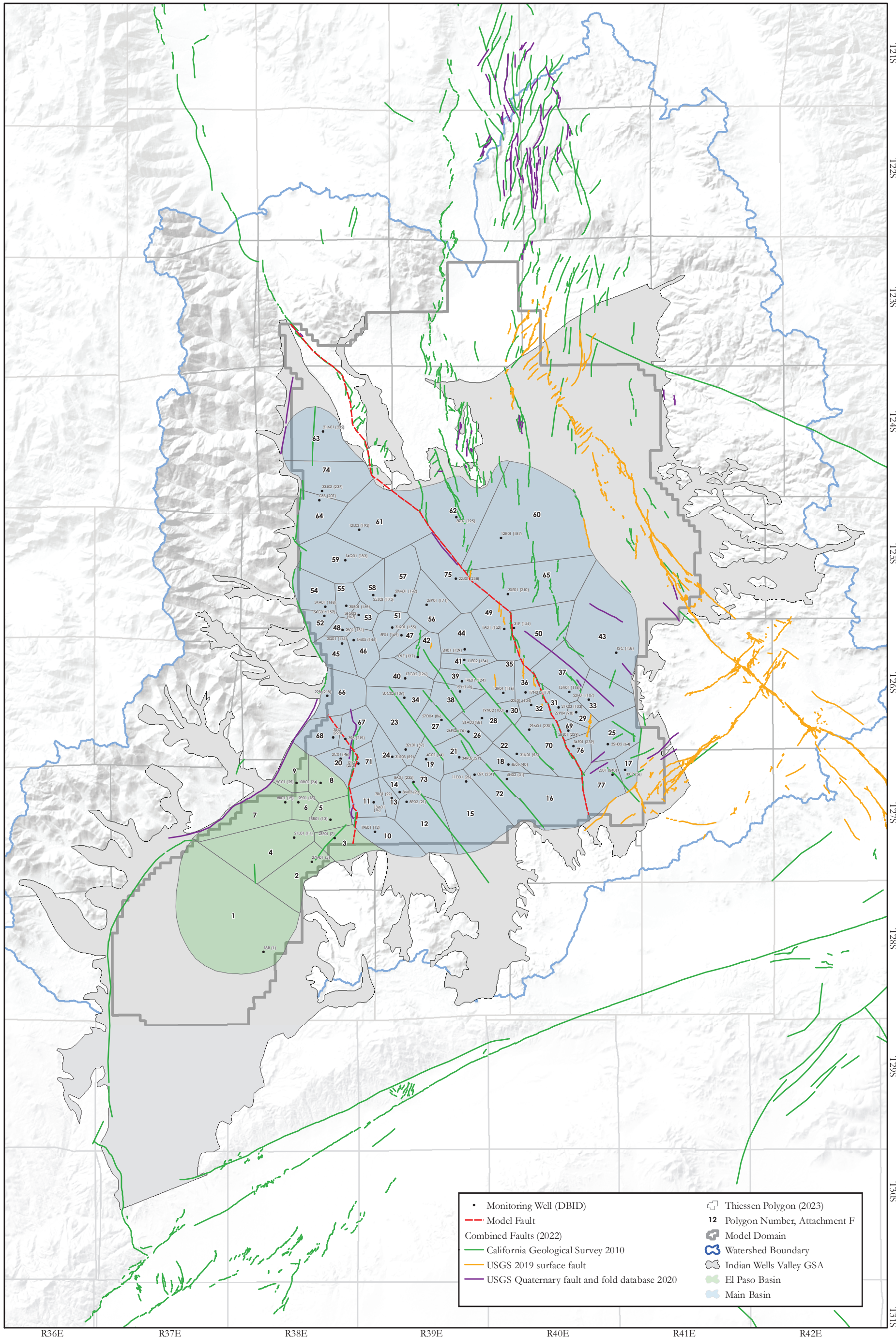

- Monitoring Well (DBID)
- Model Fault
- Combined Faults (2022)
- California Geological Survey 2010
- USGS 2019 surface fault
- USGS Quaternary fault and fold database 2020
- Thiessen Polygon (2023)
- 12 Polygon Number, Attachment F
- Model Domain
- Watershed Boundary
- Indian Wells Valley GSA
- El Paso Basin
- Main Basin



DBID: Database ID used in Data Management System (DMS) website invgsf.com

**MODIFIED THIESSEN POLYGON METHOD
ESTIMATING CHANGES TO GROUNDWATER IN STORAGE
INDIAN WELLS VALLEY, CA**

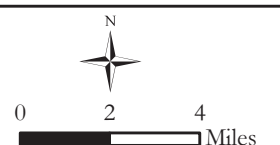
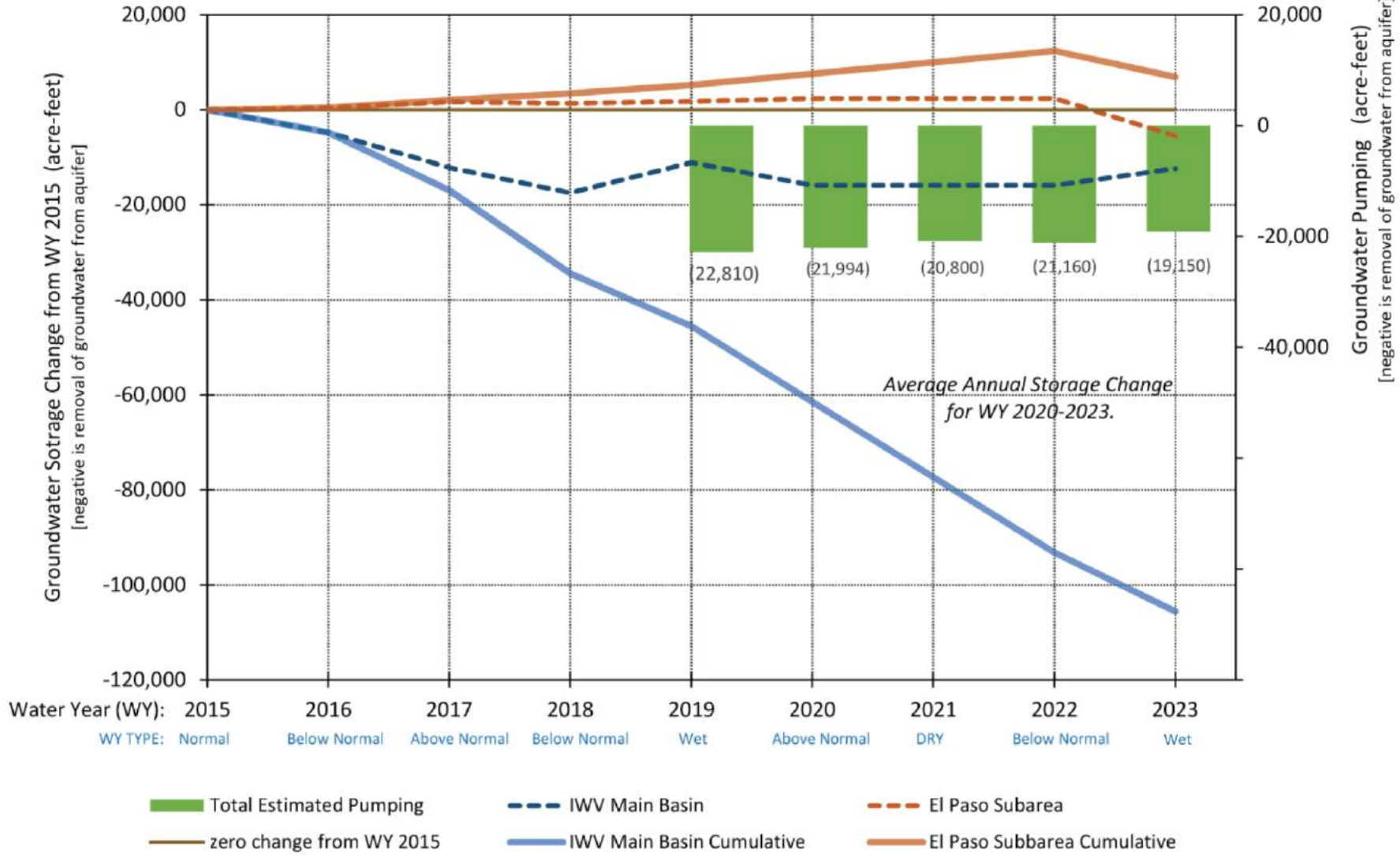
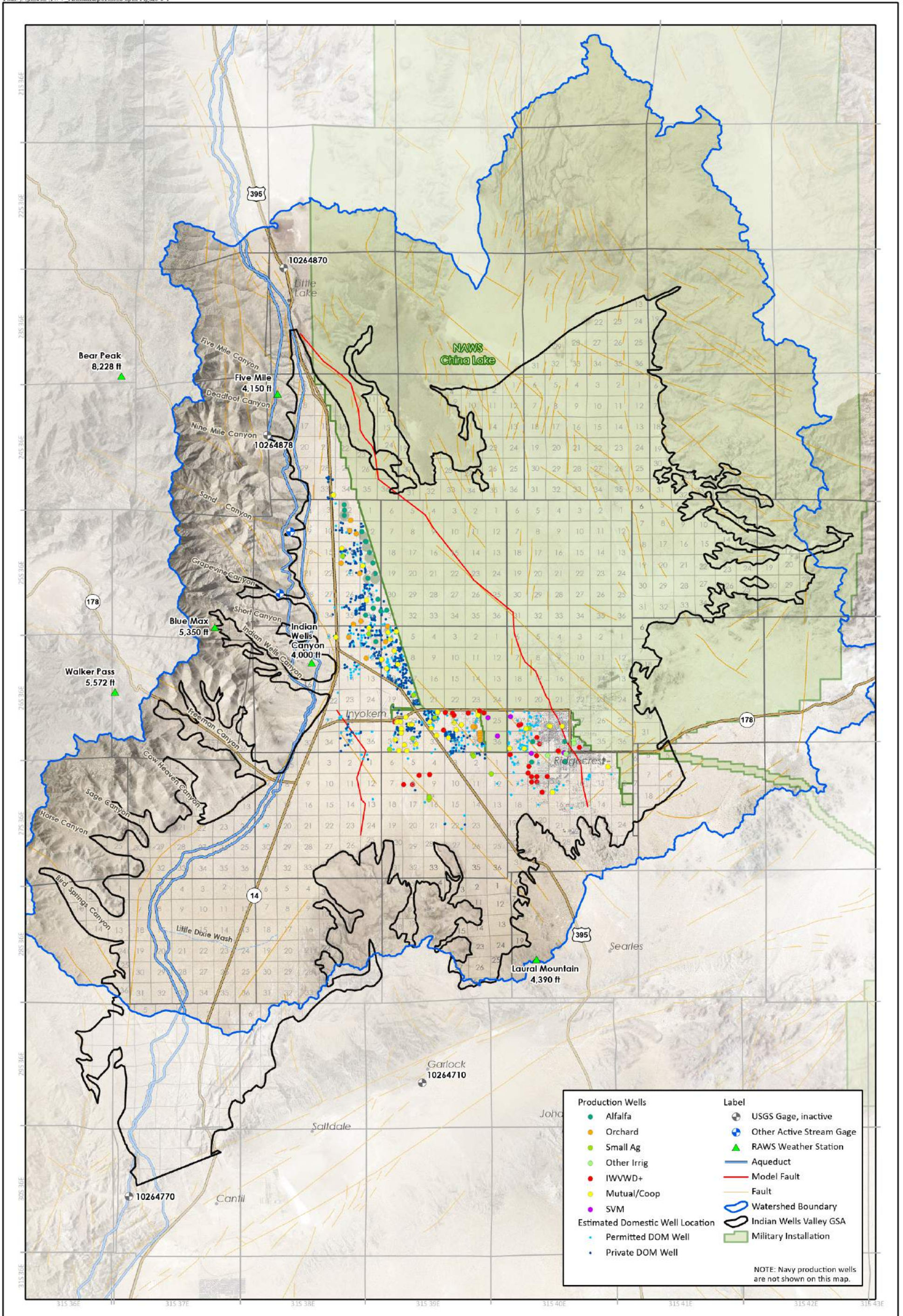

FIGURE 5-7



**ESTIMATED GROUNDWATER STORAGE CHANGE WY 2016-2023
WITH RECENT GROUNDWATER PUMPING
INDIAN WELLS VALLEY, CA**

Note: Groundwater storage change is estimated based on the Thiessen polygon method for measured area of basin (see IWV Annual Report).



PUMPING WELL LOCATION MAP
INDIAN WELLS VALLEY, CA



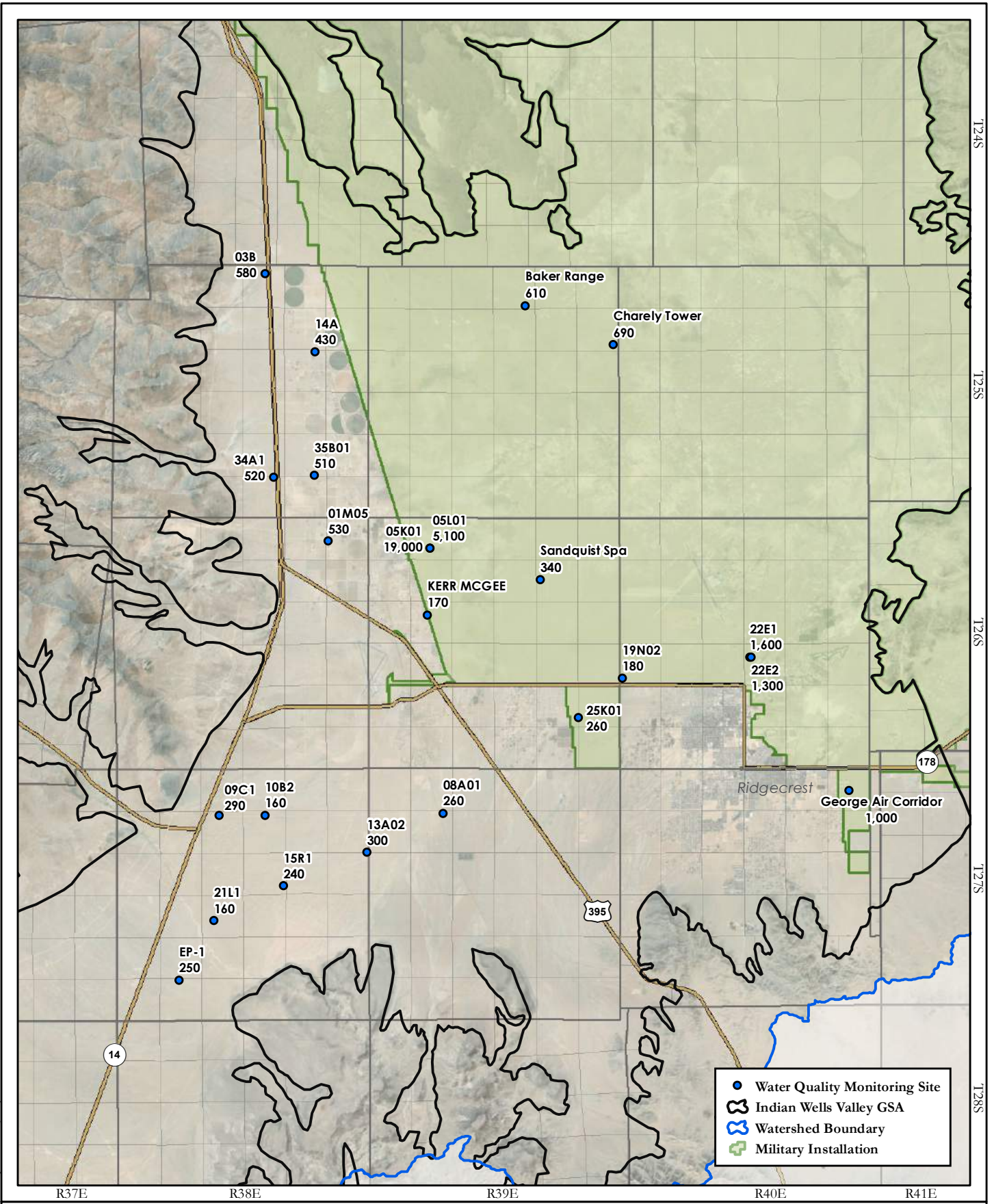

Document Path: \\jpn2652\AnnualReport2023_ Quality_TDS.mxd



TDS concentrations are in (mg/L)

GROUNDWATER QUALITY - TDS
OCTOBER 2022
INDIAN WELLS VALLEY, CA

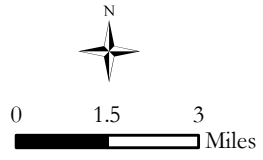

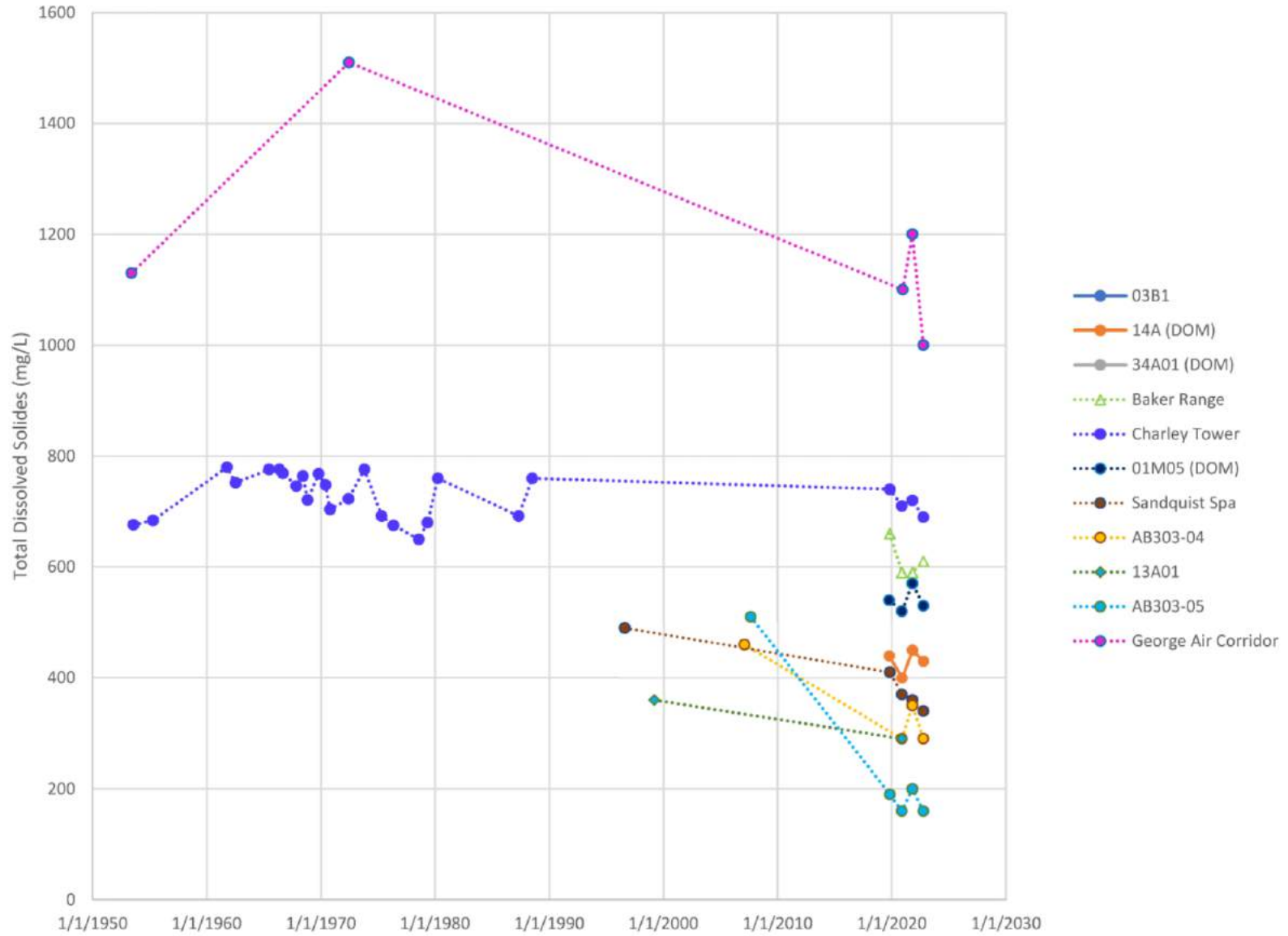

**HISTORICAL TDS CONCENTRATIONS
INDIAN WELLS VALLEY, CA**



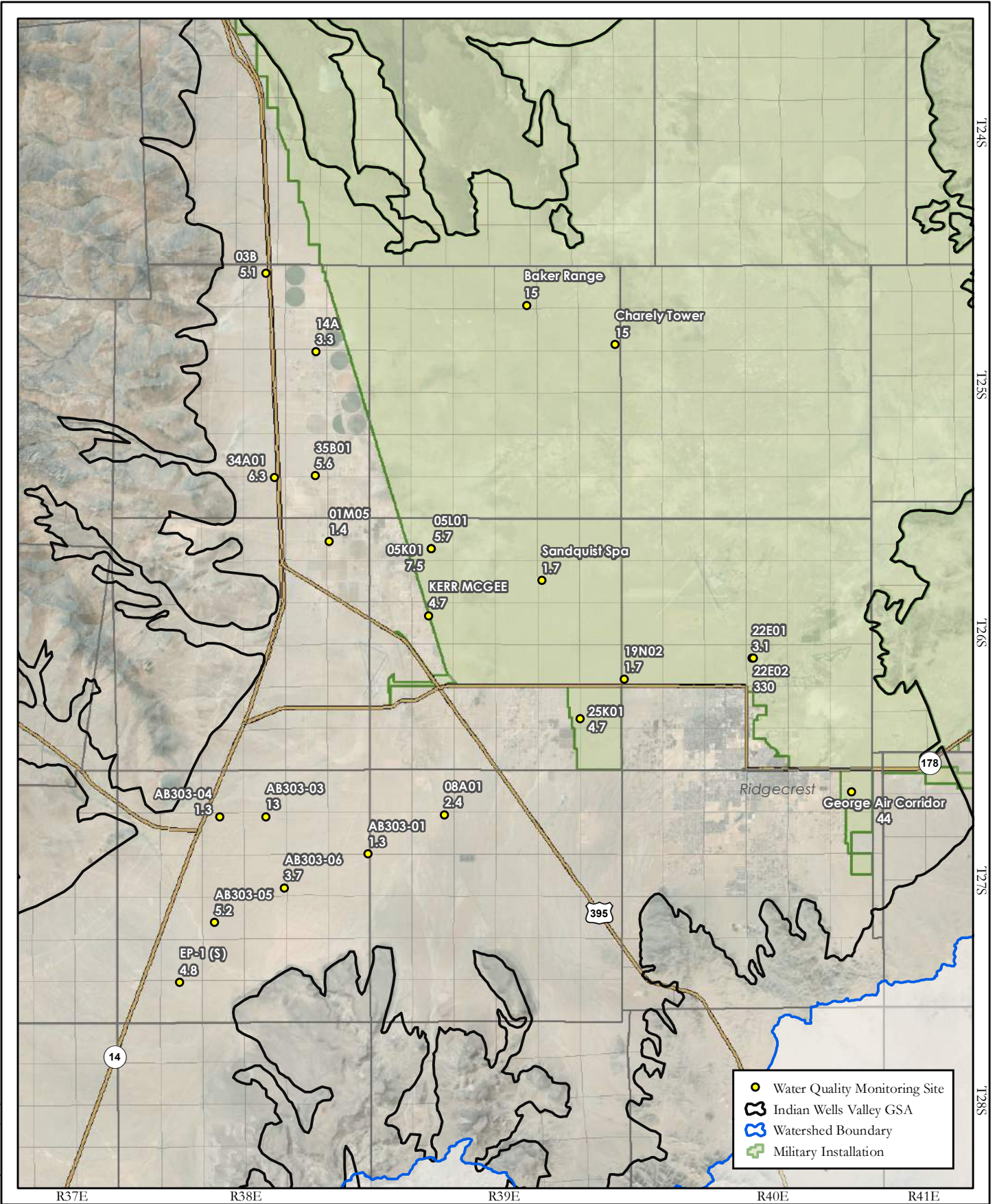

Document Path: F:\jpn2652\AnnualReport2023_Quality_Arsenic.mxd



Arsenic concentrations are in (µg/L)

**GROUNDWATER QUALITY - ARSENIC
OCTOBER 2022
INDIAN WELLS VALLEY, CA**



0 1.5 3
Miles

ATTACHMENTS

Attachment A

DWR Annual Report Submittal Tables

PART A: GROUNDWATER EXTRACTIIONS										
Basin Number	Water Year	Total Groundwater Extractions (AF)	Water Use Sector Urban (AF)	Water Use Sector Industrial (AF)	Water Use Sector Agricultural (AF)	Water Use Sector Managed Wetlands (AF)	Water Use Sector Managed Recharge (AF)	Water Use Sector Native Vegetation (AF)	Water Use Sector Other (AF)	Water Use Sector Other Description
6-054	2023 (Oct. 2022 - Sept. 2023)	19150	5620	2570	8110	0	0	0	2850	Other includes Federal Use: (1,380 AF) and Domestic/Mutual/Co-Ops: (1,470 AF)

PART B: GROUNDWATER MODEL ACCURACY DESCRIPTION					
Groundwater Model Accuracy Description	Other Method(s) Volume (AF)	Other Method(s) Description	Other Method(s) Type	Other Method(s) Accuracy (%)	Other Method(s) Accuracy Description
	19150	Compilation of data from multiple sources and self-reported data (estimated using various methods) acquired through stakeholder outreach efforts and reporting efforts.			Accuracy is unknown due to data compiled from multiple sources and multiple methods including water meters, electrical meters, population estimates, and land use estimates.

PART C: SURFACE WATER SUPPLY											
Basin Number	Water Year	Methods Used To Determine	Water Source Type Central Valley Project (AF)	Water Source Type State Water Project (AF)	Water Source Type Colorado River Project (AF)	Water Source Type Local Supplies (AF)	Water Source Type Local Imported Supplies (AF)	Water Source Type Recycled Water (AF)	Water Source Type Desalination (AF)	Water Source Type Other (AF)	Water Source Type Other Description
6-054	2023 (Oct. 2022 - Sept. 2023)	Methods include meters and estimates based on total treatment plant influent.	0	0	0	0	0	1300	0	0	

PART D: TOTAL WATER USE															
Total Water Use (AF)	Methods Used To Determine	Water Source Type Groundwater (AF)	Water Source Type Surface Water (AF)	Water Source Type Recycled Water (AF)	Water Source Type Reused Water (AF)	Water Source Type Other (AF)	Water Source Type Other Description	Water Use Sector Urban (AF)	Water Use Sector Industrial (AF)	Water Use Sector Agricultural (AF)	Water Use Sector Managed Wetlands (AF)	Water Use Sector Managed Recharge (AF)	Water Use Sector Native Vegetation (AF)	Water Use Sector Other (AF)	Water Use Sector Other Description
20450		19150	0	1300	0	0		5890	2570	8310	0	0	0	3680	Other includes Federal Use: (1,380 AF), Domestic/Mutual/Co-Ops: (1,470 AF), and recycled water percolation/habitat support (830 AF).

Attachment B
Historical Water Year Types Based on
Precipitation at China Lake NAF
(No. 041733)

Annual Precipitation at China Lake NAF, No. 041733			Annual Precipitation at China Lake NAF, No. 041733		
WY	(in/yr)	Water Year Type	WY	(in/yr)	Water Year Type
1945	4.90	AN	1985	2.79	N
1946	2.77	N	1986	4.15	AN
1947	3.81	N	1987	2.82	N
1948	1.97	BN	1988	5.40	AN
1949	1.21	D	1989	1.37	BN
1950	1.90	BN	1990	1.43	BN
1951	0.25	D	1991	3.84	N
1952	4.89	AN	1992	9.11	W
1953	1.75	BN	1993	7.12	W
1954	2.80	N	1994	1.08	D
1955	1.93	BN	1995	5.23	AN
1956	1.73	BN	1996	1.91	BN
1957	2.10	N	1997	2.71	N
1958	4.45	AN	1998	6.06	W
1959	2.47	N	1999	1.53	BN
1960	3.13	N	2000	1.76	BN
1961	1.82	BN	2001	4.36	AN
1962	3.87	N	2002	0.54	D
1963	4.03	N	2003	4.35	AN
1964	1.54	BN	2004	3.22	N
1965	4.74	AN	2005	5.88	AN
1966	5.85	AN	2006	2.61	N
1967	2.57	N	2007	0.46	D
1968	4.65	AN	2008	3.18	N
1969	5.29	AN	2009	1.16	D
1970	3.68	N	2010	3.36	N
1971	2.95	N	2011	3.98	N
1972	1.55	BN	2012	1.32	BN
1973	3.76	N	2013	0.83	D
1974	5.98	AN	2014	1.44	BN
1975	3.39	N	2015	3.67	N
1976	3.64	N	2016	1.38	BN
1977	4.01	N	2017	4.61	AN
1978	10.96	W	2018	1.43	BN
1979	6.53	W	2019	6.13	W
1980	5.66	AN	2020	5.57	AN
1981	3.23	N	2021	0.58	D
1982	4.40	AN	2022	1.87	BN
1983	10.42	W	2023	8.27	W
1984	4.05	N			

Attachment C

Groundwater Monitoring Program Updates



TECHNICAL NOTE

1901 Camino Vida Roble, Suite 105 • Carlsbad, California • 92008
Phone: (760) 730-0701 FAX: (415) 457-1638 Web site: www.stetsonengineers.com

November 2023

GROUNDWATER MONITORING PROGRAM UPDATES

Groundwater levels have been measured in IWV groundwater basin since the 1920's. Starting in 1989, the Kern County Water Agency (KCWA), the Naval Air Weapons Station (NAWS), and multiple other entities (USGS, BLM, USBR, and IWWVD) collected depth to water (DTW) measurements within the basin. In 1995, the IWV Cooperative Groundwater Management Group was formed to coordinate monitoring and management efforts of groundwater level data across IWV. The management of this program was taken over by the Indian Wells Valley Groundwater Authority (IWVGA) in 2018.

At the time the program was taken over by the IWVGA, KCWA measured 198 DTW levels in 171 groundwater wells and 9 multi-level groundwater wells (27 piezometers)¹. Wells monitored consists of private and public water production wells and monitoring wells. These data provide a strong foundation for understanding the trends and state of water resources within the Basin.

Since 2018, updates have been made to the monitoring program to assure that the GWMP is representative of current basin monitoring. Depth to water is measured at accessible monitoring wells during Spring (March) and Fall (October) to observe seasonal changes in groundwater levels. The existing WY 2023 program contains 176 monitoring wells throughout the basin including 10 multi-level monitoring wells (30 piezometers), 47 domestic wells, and 60 wells on the Navy base. The wells in the existing WY 2023 GWMP have varying supporting data, with limited well log and construction data. Table 1 summarizes existing wells monitored for groundwater levels by different areas within the IWVGB.

The Water Resource Manager continues an ongoing effort to fill in data gaps and update the monitoring wells included in the GWMP. Table 2 and Table 3 detail wells added to and removed from the GWMP, respectively. Figure 1 shows the current GWMP and changes made since the Water Year 2022 Indian Wells Valley GSP Annual Report.

- Removal of 5 Wells from the GWMP – Five wells were removed from the GWMP during the WY 2023 review. Wells removed from the GWMP are listed below.
 1. **25S/38E-35A (Domestic)** – Well 35A is a domestic well monitored by KCWA. KCWA has encountered issues accessing this well dating back to 2002. Both KCWA and the

¹ These wells are described in Section 3.6 of the Groundwater Sustainability Plan (GSP, 2020).

IWVGA have been unable to re-establish contact with the owner of this well, and as a result DTW measurements have been discontinued. The last DTW measurement at this well was in October 2018.

2. **26S/39E-34P04 (Domestic)** – Well 34P04 is a domestic well monitored by KCWA. KCWA has been locked out of this well since 2019. Both KCWA and the IWVGA have been unable to reestablish contact with the owner of this well, and as a result DTW measurements have been discontinued. The last DTW measurement at this well was in October 2018.
 3. **26S/40E-23C01 (Navy)** – Well 23C01 is a monitoring well monitored located on NAWS China Lake and monitored by Navy personnel. Well 23C01 has been dry since 2006, and as such, Navy personnel have requested measurements at this well be discontinued.
 4. **26S/40E-36A01 (Navy)** – Well 36A01 is a monitoring well monitored located on NAWS China Lake and monitored by Navy personnel. Well 36A01 has been dry since 2010, and as such, Navy personnel have requested it be measurements at this well be discontinued.
 5. **27S/39E-03C02 (Domestic)** – Well 03C02 is a domestic well monitored by KCWA. KCWA has encountered issues accessing this well dating back to 2014. Both KCWA and the IWVGA have been unable to re-establish contact with the owner of this well, and as a result DTW measurements have been discontinued. The last DTW measurement at this well was in March 2019.
- Addition of 3 Wells to the GWMP – Three wells were added to the GWMP since WY 2022. Wells were added to fill data gaps and provide new groundwater levels. Wells added to the GWMP are detailed below.
 1. **24S/38E-16J (Sawmill Well 1)** – Well Sawmill Well 1 was added to the GWMP in Spring 2023. This well was an existing monitoring well added to fill groundwater level data gaps in the northern basin. A Solinst levellogger has been installed in this well. Groundwater level data and DTW levels in this well will be collected biannually by the IWVGA.
 2. **24S/38E-16 (Sawmill Well 4)** – Sawmill Well 4 was a monitoring well added to the GWMP in Spring 2023. This well was an existing monitoring well added to fill groundwater level data gaps in the northern basin. Groundwater level data and DTW levels in this well will be collected biannually by the IWVGA.
 3. **24S/38E-04D01 (RVS-Mid)** – RVS-Mid was drilled in 2023 in the northern basin area to monitor Rose Valley subflow. A Solinst levellogger has been installed in this well. DTW levels in this well will be collected biannually by the IWVGA.

In WY 2023, 9 domestic wells and 11 monitoring, stock, cathode, or irrigation wells were unable to be accessed in both Fall 2022 and Spring 2023. The IWVGA, with assistance from KCWA, are investigating the possibility of re-establishing access to these wells. In Fall 2022 and Spring 2023, the IWVGA has 1) been unable to contact current well owners; or 2) property ownership has changed, and the IWVGA is attempting to contact new well owners. Changes and updates to the GWMP will continue as new wells are added or removed from the program.

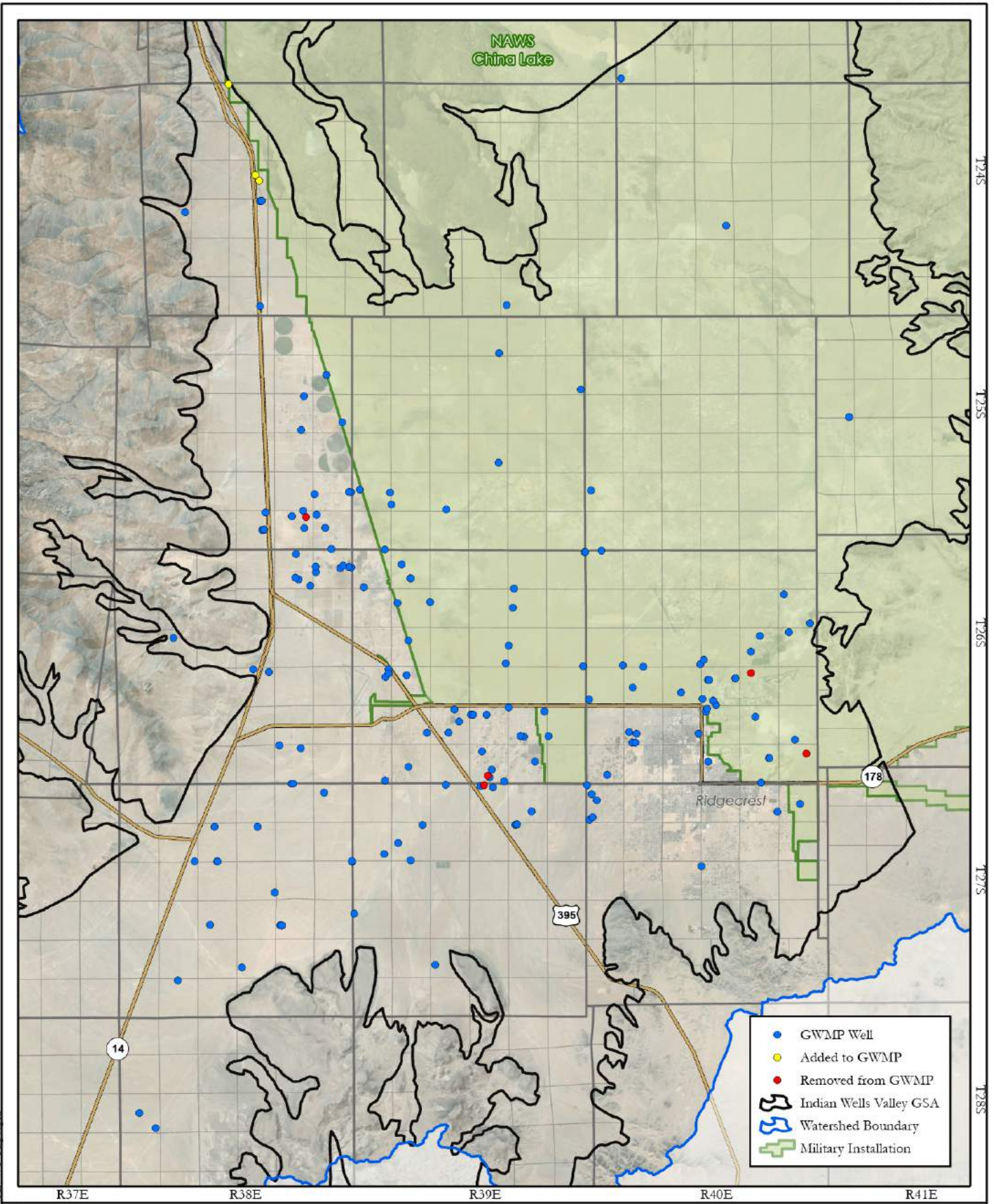

Document Path: I:\m2652\GWMP_WY_Maps.aprx



WY 2023
GROUNDWATER MONITORING PROGRAM UPDATES
 INDIAN WELLS VALLEY, CA



Table 1: Indian Wells Valley Groundwater Monitoring Program (GWMP)

Blue Text indicates a column count

176

60

DBID	State ID	Alternate Well Name	Latitude (NAD83)	Longitude (NAD83)	Well Type	NAVY
1	28S/38E-18R	Black Hills Well	35.49364	-117.92094	Stock	
2	28S/38E-18F01		35.49928	-117.92844	Stock	
5	27S/38E-27M01	USNS-03	35.55387	-117.88132	MW	
6	27S/39E-28L01	Rock Quarry	35.55472	-117.79253	Dom	
7	27S/38E-23F01	USBR 1-S	35.56959	-117.86289	MW	
8	27S/38E-23F02	USBR 1-SM	35.56968	-117.86369	MW	
10	27S/38E-23F04	USBR 1-D	35.56968	-117.86369	MW	
11	27S/38E-21L01	AB303-05	35.56985	-117.89592	MW	
12	27S/39E-19E01	IWV MW #3	35.57400	-117.82969	Stock	
13	27S/38E-15R01	AB303-06	35.58195	-117.86617	MW	
15	27S/40E-15D01	Bucket Well	35.59143	-117.67011	Dom	
16	27S/38E-13A01	Sea Bee Well	35.59345	-117.83060	MW	
17	27S/38E-09Q02	AB303-02	35.59362	-117.89262	MW	
18	27S/38E-09P01	Father Crowley	35.59363	-117.89246	MW	
19	27S/38E-08R01		35.59367	-117.90300	MW	
20	27S/38E-13A02	AB303-01	35.59369	-117.83070	MW	
21	27S/39E-08P02	IWV MW # 2	35.59393	-117.80371	MW	
22	27S/39E-07R01	Inyo	35.59634	-117.81589	MW	
23	27S/39E-08M02	IWV MW #1	35.60045	-117.80947	MW	
24	27S/38E-10B02	AB303-03	35.60662	-117.87407	MW	
25	27S/38E-09C01	AB303-04	35.60665	-117.89378	MW	
26	27S/39E-11D01	USBR 3-S	35.60731	-117.75485	MW	
27	27S/39E-11D02	USBR 3-M	35.60718	-117.75563	MW	
28	27S/39E-11D03	USBR 3-D	35.60718	-117.75563	MW	
30	27S/40E-06D01	Dist. Well 12	35.62198	-117.72253	MW	
31	27S/40E-06N02		35.60898	-117.72155	Dom	
32	27S/40E-06N01		35.60996	-117.72005	Dom	
36	27S/40E-01K02	George Air Corridor	35.61470	-117.62469	MW	
37	27S/40E-06F01		35.61629	-117.71810	Dom	
40	27S/40E-06E01		35.61855	-117.72040	Dom	
41	27S/39E-03B01		35.62127	-117.76580	Dom	
43	27S/39E-03C01		35.62174	-117.77157	Dom	
44	27S/39E-04C01		35.62224	-117.78752	Dom	
46	27S/38E-02C01	USBR 2-S	35.62280	-117.85761	Stock	
47	27S/38E-02C02	USBR 2-M	35.62274	-117.85841	Stock	
48	27S/38E-02C03	USBR 2-D	35.62274	-117.85841	Stock	
50	26S/40E-35Q02	S.E. Line	35.62274	-117.64257	Stock	✓
51	26S/39E-34R02		35.62351	-117.76068	Dom	
53	26S/40E-31K01		35.62580	-117.71330	Dom	
56	26S/39E-34K03		35.62791	-117.76635	Dom	
57	26S/39E-32L01		35.62902	-117.80461	Dom	

Table 1: Indian Wells Valley Groundwater Monitoring Program (GWMP)

Blue Text indicates a column count

176			60			
DBID	State ID	Alternate Well Name	Latitude (NAD83)	Longitude (NAD83)	Well Type	NAVY
58	26S/39E-35G01		35.63079	-117.74730	Irr	
59	26S/39E-31R03	Donna Sue Water Co.	35.62389	-117.81543	Dom	
63	26S/40E-35H01	Satellite Lake 1 (west)	35.63191	-117.63896	Stock	✓
64	26S/40E-35H02	Satellite Lake 2 (east)	35.63191	-117.63869	Stock	✓
72	26S/40E-29N01		35.63792	-117.70175	Dom	
73	26S/40E-29P01		35.63791	-117.70032	Dom	
75	26S/39E-26P01		35.64024	-117.75147	Irr	
76	26S/39E-26P02		35.64052	-117.75313	Irr	
77	26S/39E-29J02		35.64181	-117.79611	Dom	
78	26S/39E-28L02		35.64182	-117.78619	Dom	
80	26S/39E-28G02		35.64601	-117.78135	Dom	
82	26S/40E-26F01		35.64746	-117.64508	Stock	✓
84	26S/39E-27D02	MW 32-SM	35.64852	-117.77493	MW	
85	26S/39E-27D03	MW 32-DM	35.64857	-117.77591	MW	
86	26S/39E-27D04	MW 32-D	35.64857	-117.77591	MW	
87	26S/40E-27D02		35.64941	-117.66785	Stock	✓
88	26S/39E-26A03	USBR 4-SM	35.64966	-117.74213	MW	
90	26S/39E-28B03		35.65050	-117.78352	Dom	
92	26S/40E-27D01		35.65052	-117.66730	Stock	✓
94	26S/39E-20L		35.66560	-117.81374	Stock	
95	26S/40E-22P02	PW Substation 3	35.65191	-117.66313	Stock	✓
97	26S/40E-22P03	PW Substation 1	35.65357	-117.66452	MW	✓
98	26S/40E-22P04	PW Substation 2	35.65357	-117.66452	MW	✓
100	26S/40E-19N02		35.65413	-117.72147	MW	✓
101	26S/40E-22N01		35.65423	-117.66940	Stock	✓
103	26S/40E-21K03		35.65663	-117.67924	Stock	✓
104	26S/40E-20L01		35.65857	-117.70147	Stock	✓
105	26S/40E-22H01		35.66190	-117.65424	Stock	✓
106	26S/40E-22H02		35.66190	-117.65424	Stock	✓
107	26S/40E-22H03		35.66190	-117.65424	Stock	✓
108	26S/39E-20N01	ICSD MW #2	35.66274	-117.81508	MW	
109	26S/39E-20C02		35.66337	-117.80541	Dom	
112	26S/39E-20N02	ICSD MW #3	35.66413	-117.81369	MW	
114	26S/38E-22D		35.66566	-117.87597	MW	
115	26S/39E-13R03	USNS-01	35.66663	-117.72424	Stock	✓
116	26S/39E-13R04		35.66663	-117.72424	MW	✓
117	26S/40E-17N01		35.66690	-117.70591	Stock	✓
118	26S/40E-15N01		35.66718	-117.67035	Stock	✓
119	26S/39E-15J		35.66774	-117.75980	Stock	✓
120	26S/40E-15N02		35.66885	-117.66869	Stock	✓
122	26S/40E-14L01		35.67190	-117.64702	Stock	✓

Table 1: Indian Wells Valley Groundwater Monitoring Program (GWMP)

Blue Text indicates a column count

176			60			
DBID	State ID	Alternate Well Name	Latitude (NAD83)	Longitude (NAD83)	Well Type	NAVY
124	26S/39E-14E01		35.67440	-117.75841	Stock	✓
126	26S/39E-17G02	Kerr McGee	35.67635	-117.80452	MW	✓
127	26S/40E-14B01		35.67774	-117.64285	Stock	✓
129	26S/40E-13C02		35.67913	-117.62952	MW	✓
131	26S/40E-12R01	Chub Med	35.68246	-117.61980	Stock	✓
134	26S/39E-11E02	Sandquist Spa	35.68857	-117.75647	MW	✓
136	26S/39E-08F		35.69051	-117.80952	Stock	✓
137	26S/39E-09E		35.69079	-117.79452	Stock	✓
138	26S/40E-12C		35.69329	-117.63174	Stock	✓
139	26S/39E-02N01		35.69579	-117.75591	Stock	✓
140	26S/39E-06P01		35.69639	-117.82502	Dom	
141	26S/38E-02R01		35.69703	-117.84962	MW	
144	26S/38E-02Q02		35.69941	-117.85503	Dom	
145	26S/38E-02Q01		35.70000	-117.85645	Dom	
146	26S/38E-01M05		35.70215	-117.84707	Dom	
147	26S/38E-01G02		35.70363	-117.83580	Dom	
148	26S/38E-01H03		35.70384	-117.83079	Dom	
149	26S/39E-05F01	Well 23	35.70496	-117.80758	Unk	✓
151	26S/38E-02B01		35.70886	-117.85615	Dom	
152	26S/39E-01A01		35.70940	-117.72341	Stock	✓
153	26S/39E-01A02		35.70940	-117.72313	Stock	✓
154	25S/40E-31P		35.70996	-117.71563	Stock	✓
155	25S/39E-31R01		35.71051	-117.81536	MW	✓
156	25S/38E-36P		35.71076	-117.83996	Dom	
157	25S/38E-34G01	USBR 5-S	35.71813	-117.87090	MW	
158	25S/38E-34G02	USBR 5-M	35.71801	-117.87175	MW	
159	25S/38E-34G03	USBR 05-D	35.71801	-117.87175	Mun	
160	25S/38E-35H		35.71860	-117.85238	Dom	
161	25S/38E-36G01	NR-2 (Shallow)	35.71868	-117.84271	MW	
162	25S/38E-36G02	NR-2 (Middle)	35.71868	-117.84271	MW	
163	25S/38E-36G03	NR-2 (Deep)	35.71868	-117.84271	MW	
165	25S/38E-35C		35.72307	-117.85805	Dom	
166	25S/38E-36D		35.72366	-117.84667	Dom	
168	25S/38E-34A01		35.72453	-117.87024	Dom	
169	25S/38E-35B01		35.72509	-117.85286	MW	
171	25S/39E-28P01	Baker 4-NE	35.72551	-117.78701	Stock	✓
172	25S/39E-29M01		35.73190	-117.81286	Stock	✓
173	25S/38E-25J01	NR 1-S	35.73218	-117.83175	Stock	
174	25S/38E-25J02	NR 1-M	35.73208	-117.83087	Stock	
175	25S/38E-25J03	NR 1-D	35.73218	-117.83175	MW	
176	25S/39E-30E01		35.73301	-117.82675	Stock	✓

Table 1: Indian Wells Valley Groundwater Monitoring Program (GWMP)

Blue Text indicates a column count

176			60			
DBID	State ID	Alternate Well Name	Latitude (NAD83)	Longitude (NAD83)	Well Type	NAVY
183	25S/38E-14Q01		35.75542	-117.85372	Dom	
184	25S/38E-13J01		35.75829	-117.83480	Stock	✓
187	25S/39E-12R01	Charely Tower; Well 22	35.77039	-117.72496	Dom	✓
191	25S/38E-12L01	USBR 6-S	35.77607	-117.84203	MW	✓
192	25S/38E-12L02	USBR 6-M	35.77607	-117.84203	MW	✓
193	25S/38E-12L03	USBR 6-D	35.77607	-117.84203	MW	✓
195	25S/39E-03R01	Baker Range	35.78412	-117.76257	MW	✓
199	24S/39E-34D01	Baker-North	35.80213	-117.75901	MW	✓
202	24S/38E-21A01	USBR 10-S	35.84143	-117.87176	MW	
203	24S/38E-21A02	USBR 10-SM	35.84134	-117.87258	MW	
205	24S/38E-21A04	USBR 10-D	35.84134	-117.87258	MW	
208	25S/38E-25M		35.73135	-117.84767	Dom	
210	25S/40E-30E01	TTBK MW14	35.73254	-117.72033	MW	✓
211	25S/41E-18R01	TTBK MW12	35.75969	-117.60148	MW	✓
212	26S/38E-01E03		35.70417	-117.84716	Dom	
215	26S/38E-01H05		35.70406	-117.83200	Dom	
216	26S/38E-01H06		35.70453	-117.83447	Dom	
218	26S/38E-22B		35.66466	-117.86875	Dom	
219	26S/38E-35B		35.63608	-117.85408	Dom	
220	26S/38E-35D		35.63714	-117.86398	Unk	
223	26S/39E-27C01		35.64849	-117.76864	Unk	
224	26S/39E-34C01		35.63472	-117.77080	Dom	
227	26S/39E-34Q01		35.62502	-117.76733	Dom	
229	26S/40E-28J01	Hospital	35.64121	-117.67128	Mun	
230	26S/40E-29M01		35.64186	-117.70314	Dom	
231	26S/40E-29M02		35.64125	-117.69973	Dom	
233	27S/38E-01C		35.61944	-117.84342	Dom	
234	27S/39E-02K	Asphalt Construction Co.	35.61218	-117.74813	Ind/DC	
235	27S/39E-08A01		35.60721	-117.79818	MW	
237	24S/38E-33J02		35.80190	-117.87258	MW	
238	25S/39E-22J01	S. Baker Ranch	35.74300	-117.76290	MW	✓
239	26S/40E-34F01	City of Ridgecrest	35.63070	-117.66690	Cath	
240	27S/40E-02J01	DMP Cemetery	35.61176	-117.63510	Irr	
241	26S/40E-17Q01	S. Hangar 5; 96030-1	35.66638	-117.69659	MW	✓
244	24S/40E-21K02	TTIWV-MW15	35.83168	-117.65779	MW	✓
245	26S/40E-25P	MK22-MW10	35.63875	-117.62699	MW	✓
246	23S/40E-31N	E. Airport Lake Well	35.887	-117.706	MW	✓
247	24S/38E-19H	Ninemile Well	35.83719	-117.90704	MW	
248	25S/38E-14A01		35.76809	-117.85244	Dom	
249	26S/39E-05L01		35.69973	-117.80355	MW	✓
250	26S/39E-05K01		35.69973	-117.80339	MW	✓

Table 1: Indian Wells Valley Groundwater Monitoring Program (GWMP)

Blue Text indicates a column count

176

60

DBID	State ID	Alternate Well Name	Latitude (NAD83)	Longitude (NAD83)	Well Type	NAVY
251	26S/40E-22E01	CB Camp Well #1	35.66135	-117.66687	MW	✓
254	25S/39E-29N01		35.72744	-117.81227	MW	✓
255	26S/40E-22E02	CB Camp Well #2	35.66132	-117.66633	MW	✓
301	27S/38E-32C01	EP-01 S	35.54904	-117.91071	MW	
302	27S/38E-32C02	EP-01 M	35.54904	-117.91071	MW	
303	27S/38E-32C03	EP-01 D	35.54904	-117.91071	MW	

Table 2: Wells Added to Indian Wells Valley GWMP

Well additions that occurred from Fall 2022 to Spring 2023

Blue Text indicates a column count

3

DBID	State ID	Alternative Well Name	Latitude (NAD83)	Longitude (NAD83)	Well Type	Notes
308	24S/38E-16J	Sawmill Well 1	35.84887	-117.87292	MW	Added to fill groundwater level data gaps in the northern basin
309	24S/38E-16	Sawmill Well 4	35.85113	-117.87469	MW	Added to fill groundwater level data gaps in the northern basin
311	24S/38E-04D01	RVS-Mid	35.88517	-117.88699	MW	Drilled in WY 2023 to monitoring Rose Valley Subflow

Table 3: Wells Removed from Indian Wells Valley GWMP

Measurements discontinued & removed from GWMP in WY 2023

Blue Text indicates a column count

5

DBID	State ID	Alternative Well Name	Latitude (NAD83)	Longitude (NAD83)	Well Type	Date First Measured	Date Last Measured	Notes
164	25S/38E-35A		35.72272	-117.85156	Dom	4/16/1998	10/15/2018	Access issues dating back to 2002.
52	26S/39E-34P04		35.62565	-117.76819	Dom	3/23/2010	10/16/2018	Locked out of this well since 2019.
113	26S/40E-23C01		35.66385	-117.64702	Stock	3/23/1995	10/17/2017	Well has been dry since 2006.
66	26S/40E-36A01		35.63357	-117.62174	Stock	3/13/1989	10/15/2018	Well has been dry since 2010.
45	27S/39E-03C02		35.62206	-117.76995	Dom	10/11/2011	3/12/2019	Access issues dating back to 2014.

Attachment D

WY 2023 Groundwater Level Data

						Fall 2022			Spring 2023		
182		33				142			149		
DBID	State ID	Alternate Well Name	CASGEM	(NAD83)	(NAD83)	Date	(ft. bgs)	(ft. amsl)	Date	(ft. bgs)	(ft. amsl)
1	28S/38E-18R	Black Hills Well	X	35.49364	-117.92094	10/3/2022	197.70	2819.30	3/7/2023	193.80	2819.90
2	28S/38E-18F01			35.49928	-117.92844	10/3/2022	213.22	2813.55	3/7/2023	214.50	2815.15
5	27S/38E-27M01	USNS-03	X	35.55387	-117.88132	10/3/2022	193.60	2679.59	3/8/2023	196.28	2680.61
6	27S/39E-28L01	Rock Quarry		35.55472	-117.79253	10/3/2022	287.60	2532.40	3/7/2023	287.70	2532.30
7	27S/38E-23F01	USBR 1-S	X	35.56959	-117.86289	10/4/2022	182.24	2668.26	3/8/2023	185.61	2668.35
8	27S/38E-23F02	USBR 1-SM	X	35.56968	-117.86369	10/4/2022	179.85	2670.65	3/8/2023	185.27	2668.61
10	27S/38E-23F04	USBR 1-D		35.56968	-117.86369	10/4/2022	182.25	2668.25	3/8/2023	185.27	2668.44
11	27S/38E-21L01	AB303-05	X	35.56985	-117.89592	10/3/2022	358.78	2665.38	3/9/2023	360.60	2665.27
12	27S/39E-19E01	IWV MW #3		35.57400	-117.82969	10/3/2022	204.00	2435.49	3/7/2023	207.60	2434.89
13	27S/38E-15R01	AB303-06		35.58195	-117.86617	10/3/2022	273.32	2658.67	3/7/2023	277.30	2658.29
15	27S/40E-15D01	Bucket Well		35.59143	-117.67011				3/7/2023		Dry
16	27S/38E-13A01	Sea Bee Well		35.59345	-117.83060	10/4/2022	224.93	2429.06	3/8/2023	227.49	2428.95
17	27S/38E-09Q02	AB303-02		35.59362	-117.89262	10/3/2022	419.20	2685.80	3/9/2023	422.54	2686.06
18	27S/38E-09P01	Father Crowley		35.59363	-117.89246	10/3/2022	417.80	2694.32	3/9/2023	423.83	2691.29
19	27S/38E-08R01			35.59367	-117.90300	10/3/2022	505.80	2697.54			
20	27S/38E-13A02	AB303-01		35.59369	-117.83070	10/3/2022	223.31	2426.69	3/8/2023	226.81	2425.69
21	27S/39E-08P02	IWV MW # 2		35.59393	-117.80371	10/3/2022	440.80	2140.16	3/7/2023	445.30	2138.66
22	27S/39E-07R01	Inyo		35.59634	-117.81589	10/3/2022	425.80	2138.30	3/8/2023		Dry
23	27S/39E-08M02	IWV MW #1		35.60045	-117.80947	10/3/2022	415.60	2137.83	3/7/2023	418.40	2136.03
24	27S/38E-10B02	AB303-03		35.60662	-117.87407	10/4/2022	427.84	2467.16	3/7/2023	429.00	2469.60
25	27S/38E-09C01	AB303-04		35.60665	-117.89378	10/3/2022	282.85	2787.15	3/7/2023	385.30	2688.50
26	27S/39E-11D01	USBR 3-S	X	35.60731	-117.75485	10/4/2022	371.91	2138.49	3/8/2023	371.60	2141.76
27	27S/39E-11D02	USBR 3-M	X	35.60718	-117.75563	10/4/2022	363.56	2146.84	3/8/2023	366.46	2146.86
28	27S/39E-11D03	USBR 3-D	X	35.60718	-117.75563	10/4/2022	346.72	2163.68	3/8/2023	347.98	2165.13
30	27S/40E-06D01	Dist. Well 12		35.62198	-117.72253	10/4/2022	284.55	2122.45			
31	27S/40E-06N02			35.60898	-117.72155	10/4/2022	352.00	2121.73	3/7/2023	348.80	2124.93
32	27S/40E-06N01			35.60996	-117.72005	10/4/2022	350.10	2121.49	3/7/2023	348.70	2122.89
36	27S/40E-01K02	George Air Corridor	X	35.61470	-117.62469	10/3/2022	163.51	2159.13	3/9/2023	164.76	2159.38
37	27S/40E-06F01			35.61629	-117.71810	10/4/2022	318.70	2120.86	3/9/2023	318.29	2122.27
40	27S/40E-06E01			35.61855	-117.72040	10/4/2022	313.90	2118.99	3/7/2023	311.30	2121.59
41	27S/39E-03B01			35.62127	-117.76580						
43	27S/39E-03C01			35.62174	-117.77157						
44	27S/39E-04C01			35.62224	-117.78752				3/7/2023	351.70	2149.40
45	27S/39E-03C02			35.62206	-117.76995						
46	27S/38E-02C01	USBR 2-S	X	35.62280	-117.85761	10/3/2022	281.76	2373.19	3/7/2023	284.30	2373.19
47	27S/38E-02C02	USBR 2-M	X	35.62274	-117.85841	10/3/2022	273.82	2381.13	3/7/2023	276.10	2381.23
48	27S/38E-02C03	USBR 2-D	X	35.62274	-117.85841	10/3/2022	281.87	2373.08	3/7/2023	283.90	2373.38
50	26S/40E-35Q02	S.E. Line		35.62274	-117.64257	10/4/2022	94.63	2158.20	3/7/2023	98.32	2158.01
51	26S/39E-34R02			35.62351	-117.76068				3/9/2023	324.50	2127.21
52	26S/39E-34P04			35.62565	-117.76819						
53	26S/40E-31K01			35.62580	-117.71330						
56	26S/39E-34K03			35.62791	-117.76635	10/4/2022	329.50	2146.12	3/7/2023	329.80	2146.82
57	26S/39E-32L01			35.62902	-117.80461	10/3/2022	342.60	2149.44	3/7/2023	346.00	2147.04
58	26S/39E-35G01			35.63089	-117.74645						
59	26S/39E-31R03			35.62389	-117.81543						
63	26S/40E-35H01	Satellite Lake 1 (west)		35.63191	-117.63896	10/4/2022	90.73	2161.62	3/7/2023	92.14	2161.41
64	26S/40E-35H02	Satellite Lake 2 (east)		35.63191	-117.63869	10/4/2022	98.52	2153.51	3/7/2023	100.89	2153.54
66	26S/40E-36A01			35.63357	-117.62174						
72	26S/40E-29N01			35.63792	-117.70175						
73	26S/40E-29P01			35.63791	-117.70032	10/4/2022	208.10	2122.59	3/8/2023	198.50	2133.19

75	26S/39E-26P01			35.64024	-117.75147	10/3/2022	266.70	2136.63	3/7/2023	264.10	2140.23
76	26S/39E-26P02			35.64052	-117.75313	10/3/2022	269.60	2136.66	3/7/2023	267.30	2139.96
77	26S/39E-29J02			35.64181	-117.79611	10/3/2022	304.70	2124.30	3/7/2023	304.10	2124.90
78	26S/39E-28L02			35.64182	-117.78619						
80	26S/39E-28G02			35.64601	-117.78135	10/4/2022	286.40	2146.62	3/7/2023	287.20	2146.82
82	26S/40E-26F01			35.64746	-117.64508	10/4/2022	59.37	2173.43	3/7/2023	62.68	2173.12
84	26S/39E-27D02	MW 32-SM	X	35.64852	-117.77493	10/4/2022	301.22	2117.31	3/7/2023	280.51	2141.06
85	26S/39E-27D03	MW 32-DM	X	35.64857	-117.77591	10/4/2022	291.88	2126.65	3/7/2023	280.73	2140.84
86	26S/39E-27D04	MW 32-D	X	35.64857	-117.77591	10/4/2022	280.57	2137.96	3/7/2023	280.76	2140.42
87	26S/40E-27D02			35.64941	-117.66785	10/4/2022	45.92	2220.83	3/7/2023	46.98	2220.67
88	26S/39E-26A03	USBR 4	X	35.64966	-117.74213	10/3/2022	252.25	2124.84	3/9/2023	248.55	2130.39
90	26S/39E-28B03			35.65050	-117.78352	10/3/2022	250.30	2176.35	3/7/2023	251.20	2176.45
92	26S/40E-27D01			35.65052	-117.66730	10/4/2022	72.22	2195.82	3/7/2023	71.52	2195.52
94	26S/39E-20L			35.66560	-117.81374	10/3/2022	241.10	2186.89	3/7/2023	242.70	2187.19
95	26S/40E-22P02	PW Substation 3		35.65191	-117.66313	10/4/2022	65.64	2201.58	3/7/2023	69.32	2201.60
97	26S/40E-22P03	PW Substation 1		35.65357	-117.66452	10/4/2022	113.38	2145.50	3/7/2023	112.40	2147.48
98	26S/40E-22P04	PW Substation 2		35.65357	-117.66452	10/4/2022	53.37	2205.38	3/7/2023	53.83	2205.92
100	26S/40E-19N02			35.65413	-117.72147	10/3/2022	209.00	2128.43	3/7/2023	208.92	2129.51
101	26S/40E-22N01			35.65423	-117.66940				3/7/2023	92.98	2171.38
103	26S/40E-21K03			35.65663	-117.67924	10/4/2022	100.28	2166.51	3/7/2023	102.06	2167.53
104	26S/40E-20L01			35.65857	-117.70147	10/4/2022	145.92	2150.93	3/7/2023	149.71	2150.74
105	26S/40E-22H01			35.66190	-117.65424	10/4/2022	33.03	2195.12	3/7/2023	35.51	2195.54
106	26S/40E-22H02			35.66190	-117.65424	10/4/2022	33.01	2195.37	3/7/2023	36.12	2195.56
107	26S/40E-22H03			35.66190	-117.65424	10/4/2022	33.06	2194.68	3/7/2023	35.65	2195.09
108	26S/39E-20N01	ICSD MW #2		35.66274	-117.81508						
109	26S/39E-20C02			35.66337	-117.80541	10/3/2022	241.50	2149.36	3/7/2023	242.30	2149.56
112	26S/39E-20N02	ICSD MW #3		35.66413	-117.81369						
113	26S/40E-23C01			35.66385	-117.64702						
114	26S/38E-22D			35.66566	-117.87597	10/3/2022	57.50	2790.75	3/7/2023	58.30	2790.95
115	26S/39E-13R03	USNS-01		35.66663	-117.72424	10/4/2022	152.74	2166.61	3/7/2023	154.25	2166.40
116	26S/39E-13R04			35.66663	-117.72424	10/4/2022	197.63	2122.18	3/7/2023	193.71	2127.60
117	26S/40E-17N01			35.66690	-117.70591	10/4/2022	142.82	2152.26	3/7/2023	144.62	2152.26
118	26S/40E-15N01			35.66718	-117.67035	10/4/2022	58.20	2186.58	3/7/2023	60.94	2186.44
119	26S/39E-15J			35.66774	-117.75980	10/4/2022	203.80	2143.99	3/6/2023	210.45	2144.34
120	26S/40E-15N02			35.66885	-117.66869	10/4/2022	51.23	2185.14	3/7/2023	54.43	2185.14
121	26S/40E-17J01			35.67107	-117.69480						
122	26S/40E-14L01			35.67190	-117.64702	10/4/2022	21.72	2183.95	3/7/2023	23.11	2185.46
124	26S/39E-14E01			35.67440	-117.75841	10/4/2022	170.39	2164.94	3/6/2023	171.75	2164.58
126	26S/39E-17G02	Kerr McGee		35.67635	-117.80452	10/3/2022	210.10	2146.44	3/6/2023	209.95	2148.09
127	26S/40E-14B01			35.67774	-117.64285	10/4/2022	9.68	2181.37	3/7/2023	10.64	2182.41
129	26S/40E-13C02			35.67913	-117.62952	10/4/2022	10.07	2178.29	3/7/2023	10.74	2178.62
131	26S/40E-12R01	Chub Med		35.68246	-117.61980	10/4/2022	2.77	2182.56	3/7/2023	4.88	2182.35
134	26S/39E-11E02	Sandquist Spa	X	35.68857	-117.75647	10/3/2022	136.51	2170.79	3/6/2023	138.05	2170.25
136	26S/39E-08F			35.69051	-117.80952	10/4/2022	168.40	2150.92	3/6/2023	169.96	2150.36
137	26S/39E-09E			35.69079	-117.79452	10/4/2022	173.13	2139.38	3/6/2023	172.60	2142.41
138	26S/40E-12C			35.69329	-117.63174	10/4/2022	5.48	2160.65	3/6/2023	6.92	2160.71
139	26S/39E-02N01			35.69579	-117.75591	10/3/2022	114.40	2172.23	3/6/2023	115.65	2171.98
140	26S/39E-06P01			35.69639	-117.82502	10/3/2022	163.00	2157.00	3/7/2023	164.40	2157.00
141	26S/38E-02R01			35.69703	-117.84962						
144	26S/38E-02Q02			35.69941	-117.85503	10/3/2022	275.00	2134.50	3/7/2023	253.00	2158.60
145	26S/38E-02Q01			35.70000	-117.85645	10/3/2022	255.80	2153.44	3/7/2023	254.30	2155.94
146	26S/38E-01M05			35.70215	-117.84707	10/5/2022	215.41	2158.02	3/7/2023	214.40	2160.03
147	26S/38E-01G02			35.70363	-117.83580	10/3/2022	180.70	2157.81	3/7/2023	179.50	2160.01
148	26S/38E-01H03			35.70384	-117.83079				3/7/2023	184.00	2135.82
149	26S/39E-05F01			35.70496	-117.80758	10/4/2022	113.62	2163.98	3/6/2023	113.32	2164.28
151	26S/38E-02B01			35.70886	-117.85615	10/3/2022	215.10	2157.76	3/7/2023	214.90	2159.16

152	26S/39E-01A01			35.70940	-117.72341	10/3/2022	42.12	2175.52	3/6/2023	43.90	2175.34
153	26S/39E-01A02			35.70940	-117.72313	10/3/2022	43.16	2174.77	3/6/2023	45.83	2174.60
154	25S/40E-31P			35.70996	-117.71563	10/3/2022	18.93	2172.81	3/6/2023	21.05	2172.99
155	25S/39E-31R01			35.71051	-117.81536	10/4/2022	92.13	2169.72	3/6/2023	94.64	2169.71
156	25S/38E-36P			35.71076	-117.83996	10/3/2022	170.20	2158.80			
157	25S/38E-34G01	USBR 5-S	X	35.71813	-117.87090	10/3/2022	361.02	2159.40	3/7/2023	363.94	2159.06
158	25S/38E-34G02	USBR 5-M	X	35.71801	-117.87175	10/3/2022	368.52	2151.90	3/7/2023	371.05	2151.75
159	25S/38E-34G03	USBR 05-D	X	35.71801	-117.87175	10/3/2022	372.17	2148.25	3/7/2023	372.26	2150.29
160	25S/38E-35H			35.71860	-117.85238				3/7/2023	199.40	2158.36
161	25S/38E-36G01	NR-2 (Shallow)	X	35.71868	-117.84271						
162	25S/38E-36G02	NR-2 (Middle)	X	35.71868	-117.84271						
163	25S/38E-36G03	NR-2 (Deep)	X	35.71868	-117.84271						
164	25S/38E-35A			35.72272	-117.85156						
165	25S/38E-35C			35.72307	-117.85805	10/3/2022	265.00	2158.52	3/7/2023	264.50	2160.02
166	25S/38E-36D			35.72366	-117.84667	10/3/2022	187.00	2156.72	3/7/2023	184.70	2159.52
168	25S/38E-34A01			35.72453	-117.87024	10/3/2022	364.83	2163.95	3/7/2023	364.00	2165.78
169	25S/38E-35B01			35.72509	-117.85286	10/4/2022	239.09	2157.15	3/7/2023	239.94	2158.16
170	25S/38E-36B01	WELL 27		35.72496	-117.83675						
171	25S/39E-28P01	Baker 4-NE		35.72551	-117.78701	10/4/2022	54.08	2174.96	3/6/2023	50.48	2179.56
172	25S/39E-29M01			35.73190	-117.81286	10/4/2022	49.56	2182.74	3/6/2023	60.76	2172.54
173	25S/38E-25J01	NR 1-S		35.73218	-117.83175	10/3/2022	114.60	2162.35	3/7/2023	117.30	2162.45
174	25S/38E-25J02	NR 1-M		35.73208	-117.83087	10/3/2022	117.40	2158.30	3/7/2023	120.70	2157.80
175	25S/38E-25J03	NR 1-D		35.73218	-117.83175	10/3/2022	134.70	2141.00	3/7/2023	136.10	2142.40
176	25S/39E-30E01			35.73301	-117.82675	10/4/2022	54.48	2194.13	3/6/2023	55.55	2195.26
183	25S/38E-14Q01			35.75542	-117.85372				3/7/2023	227.50	2165.00
184	25S/38E-13J01			35.75829	-117.83480	10/4/2022	127.96	2164.01	3/6/2023	129.69	2166.08
187	25S/39E-12R01	Charely Tower; Well 22		35.77039	-117.72496	10/3/2022	25.01	2177.36	3/6/2023	26.13	2177.24
191	25S/38E-12L01	USBR 6-S	X	35.77607	-117.84203	10/4/2022	189.41	2163.51	3/6/2023	184.75	2169.96
192	25S/38E-12L02	USBR 6-M	X	35.77607	-117.84203	10/4/2022	191.59	2161.33	3/6/2023	192.22	2162.16
193	25S/38E-12L03	USBR 6-D	X	35.77607	-117.84203	10/4/2022	166.95	2185.97	3/6/2023	168.09	2185.91
195	25S/39E-03R01	Baker Range	X	35.78412	-117.76257	10/3/2022	51.42	2174.85	3/6/2023	52.68	2174.59
199	24S/39E-34D01	Baker-North		35.80213	-117.75901	10/3/2022	47.42	2179.61	3/6/2023	49.21	2179.42
202	24S/38E-21A01	USBR 10-S	X	35.84143	-117.87176	10/3/2022	320.49	2238.90	3/9/2023	325.68	2238.63
203	24S/38E-21A02	USBR 10-SM	X	35.84134	-117.87258	10/3/2022	319.95	2239.44	3/9/2023	325.50	2238.70
205	24S/38E-21A04	USBR 10-D	X	35.84134	-117.87258	10/3/2022	318.96	2240.43	3/9/2023	324.28	2239.65
207	25S/38E-03B			35.79546	-117.87382	10/4/2022	291.46	2164.89	3/8/2023	293.58	2164.37
208	25S/38E-25M			35.73135	-117.84767						
210	25S/40E-30E01	TTBK MW14	X	35.73254	-117.72033	10/3/2022	14.89	2176.15	3/6/2023	18.25	2176.00
211	25S/41E-18R01	TTBK MW12	X	35.75969	-117.60148	10/3/2022	22.16	1981.06	3/6/2023	25.35	1981.12
212	26S/38E-01E03			35.70417	-117.84716						
215	26S/38E-01H05			35.70406	-117.83200						
216	26S/38E-01H06			35.70453	-117.83447				3/7/2023	172.00	2148.20
218	26S/38E-22B	Ostrich Ranch		35.66466	-117.86875	10/3/2022	432.20	2234.08	3/7/2023	434.00	2233.28
219	26S/38E-35B			35.63608	-117.85408	10/3/2022	343.40	2231.15	3/7/2023	343.00	2231.55
220	26S/38E-35D			35.63714	-117.86398	10/3/2022	449.20	2236.03	3/7/2023	451.10	2235.53
223	26S/39E-27C01			35.64849	-117.76864						
224	26S/39E-34C01			35.63472	-117.77080						
227	26S/39E-34Q01			35.62502	-117.76733	10/4/2022	338.61	2134.49	3/8/2023	338.10	2134.90
229	26S/40E-28J01	Hospital		35.64121	-117.67128	10/3/2022	136.60	2154.32	3/7/2023	136.10	2155.82
230	26S/40E-29M01			35.64186	-117.70314	10/4/2022	207.60	2123.04	3/8/2023	206.80	2124.84
231	26S/40E-29M02			35.64125	-117.69973	10/4/2022	197.60	2127.04	3/8/2023	196.20	2129.44
233	27S/38E-01C			35.61944	-117.84342						
234	27S/39E-02K	Asphalt Construction Co.		35.61218	-117.74813	10/4/2022	316.60	2141.82	3/8/2023	316.40	2142.02
235	27S/39E-08A01			35.60721	-117.79818	10/4/2022	396.68	2137.51	3/8/2023	398.85	2136.64
237	24S/38E-33J02			35.80190	-117.87258						
238	25S/39E-22J01	S. Baker Ranch		35.74300	-117.76290	10/4/2022	42.53	2176.24	3/6/2023	43.73	2176.04

239	26S/40E-34F01	City of Ridgecrest		35.63070	-117.66690						
240	27S/40E-02J01	DMP Cemetery		35.61176	-117.63510	10/3/2022	154.50	2150.55	3/7/2023	155.00	2150.55
241	26S/40E-17Q01	S. Hangar 5; 96030-1	X	35.66638	-117.69659	10/4/2022	144.46	2132.64	3/7/2023	143.31	2136.04
244	24S/40E-21K02	TTIWW-MW15		35.83168	-117.65779	10/3/2022	50.58	2192.42	3/6/2023	52.68	2188.62
245	26S/40E-25P	MK22-MW10		35.63875	-117.62699	10/4/2022	87.05	2155.65	3/7/2023	89.52	2155.15
246	23S/40E-31N	E. Airport Lake Well		35.88700	-117.70600	10/3/2022	105.97	2192.13	3/6/2023	109.47	2191.96
247	24S/38E-19H	Ninemile Well		35.83719	-117.90704	10/4/2022	14.09	2957.16	3/7/2023	8.06	2963.21
248	25S/38E-14A01			35.76809	-117.85244	10/3/2022	234.91	2140.09	3/8/2023	232.00	2162.10
249	26S/39E-05L01			35.69973	-117.80355	10/3/2022	131.38	2162.48	3/6/2023	133.18	2162.54
250	26S/39E-05K01			35.69973	-117.80339	10/3/2022	129.39	2164.36	3/6/2023	131.37	2164.13
251	26S/40E-22E01	CB Camp Well #1		35.66135	-117.66687	10/3/2022	98.87	2144.81	3/7/2023	101.51	2144.95
254	25S/39E-29N01			35.72740	-117.81212				3/6/2023	66.89	2174.21
255	26S/40E-22E02	CB Camp Well #2		35.66132	-117.66633				3/7/2023	92.46	2154.19
301	27S/38E-32C01	EP-01 S		35.54904	-117.91071	10/4/2022	272.82	2689.84	3/8/2023	275.13	2689.99
302	27S/38E-32C02	EP-01 M		35.54904	-117.91071	10/4/2022	279.38	2683.28	3/8/2023	281.61	2683.41
303	27S/38E-32C03	EP-01 D		35.54904	-117.91071	10/4/2022	273.88	2688.78	3/8/2023	275.83	2689.04
304	26S/39E-35B01			35.63444	-117.74635						
305	26S/38E-17C01	Indian Wells Canyon		35.67749	-117.91262	10/5/2022	79.36	3389.14	3/7/2023	81.19	3386.63
306	26S/39E-27C01			35.65120	-117.78538						
307	26S/39E-25K01			35.64041	-117.74023	10/4/2022	267.74	2120.96	3/9/2023	265.07	2123.93
		Lumbermill Well #4							3/9/2023	343.64	
	25S/40E-32	TTBKMW05							3/6/2023	13.3	

Attachment E

Hydrographs for Select Monitoring Wells

**USBR 10 (2559 ft, msl)
24S/38E-21A1 - 24S/38E-21A4**

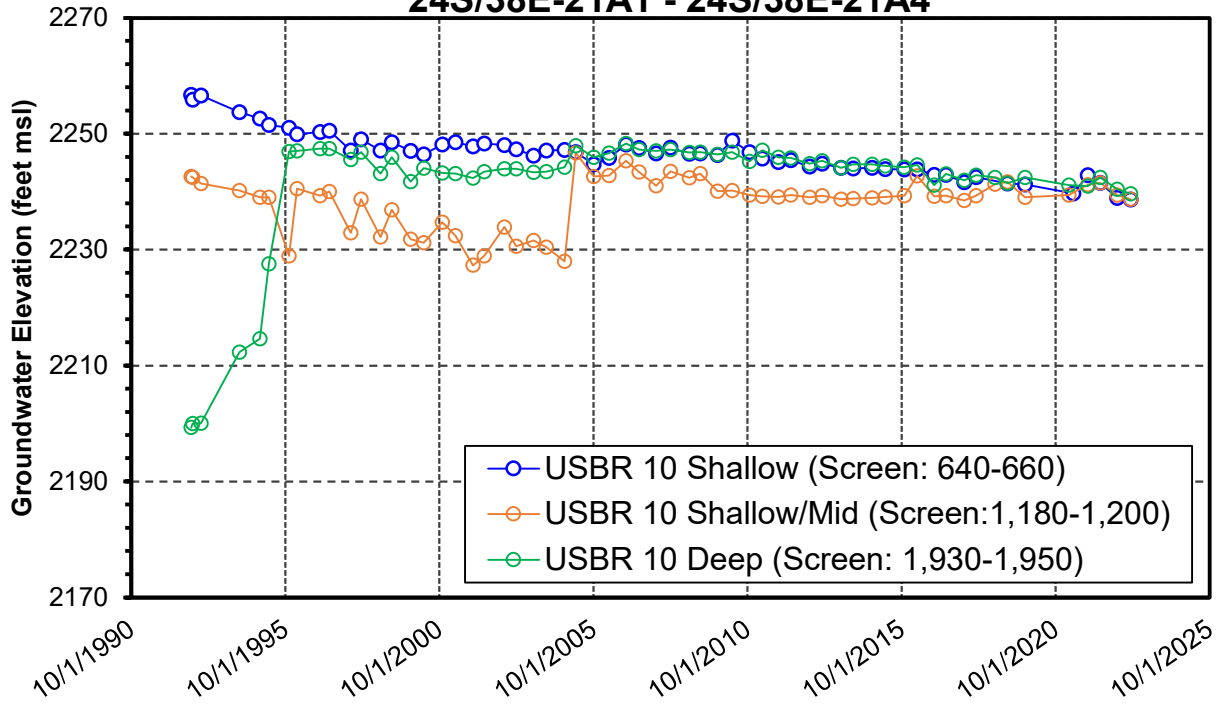

**USBR 06 (2353 ft, msl)
Representative Monitoring Site
25S/38E-12L1 - 25S/38E-12L3**

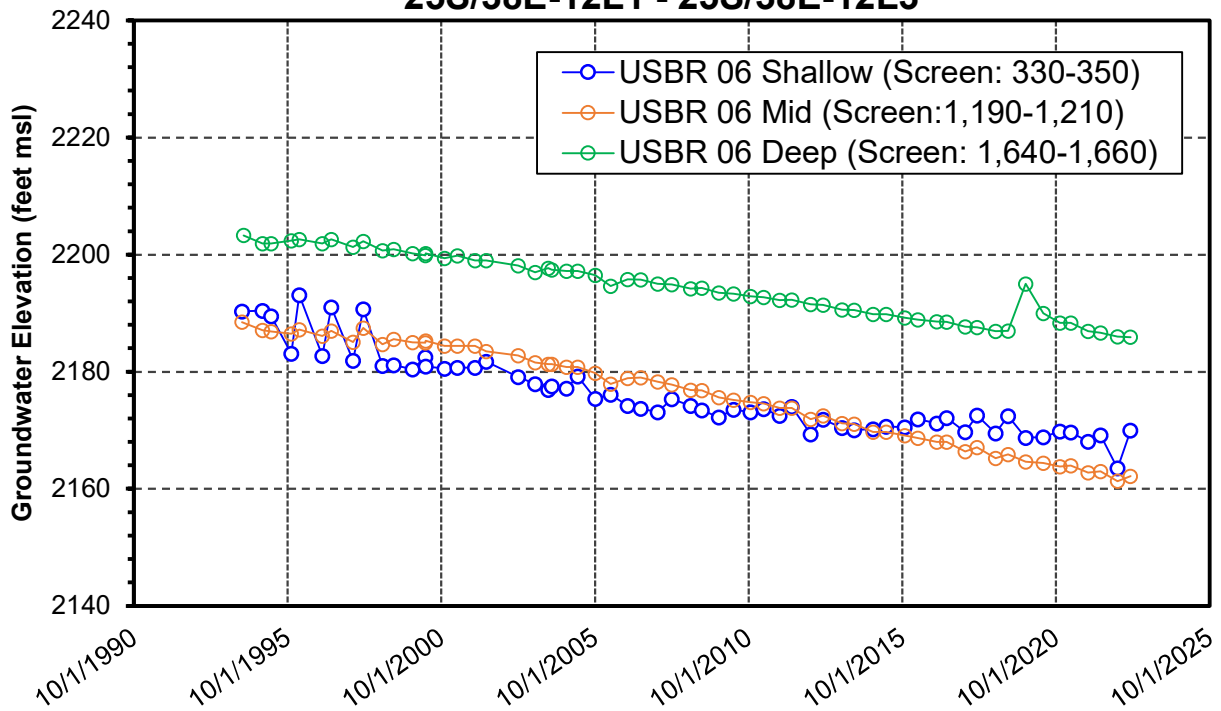

USBR 05 (2520 ft, msl)
Representative Monitoring Site
25S/38E-34G1 - 25S/38E-34G3

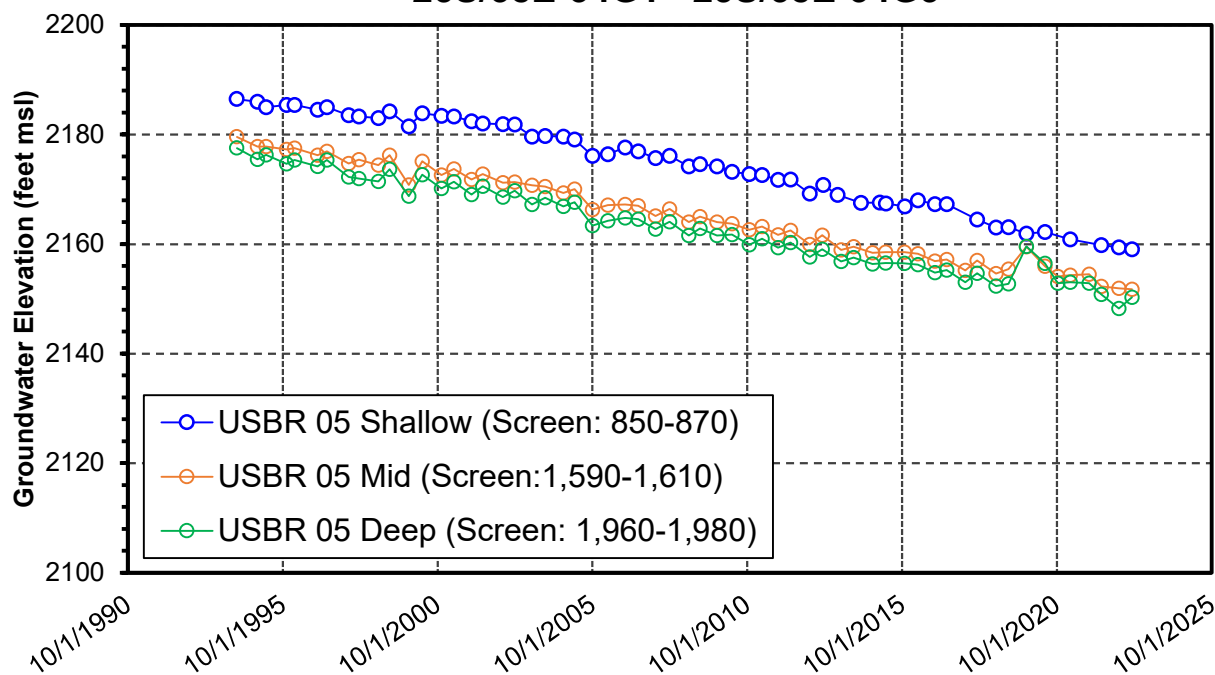

NR-2 (2315 ft, msl)
25S/38E-36G1 - 25S/38E-36G3

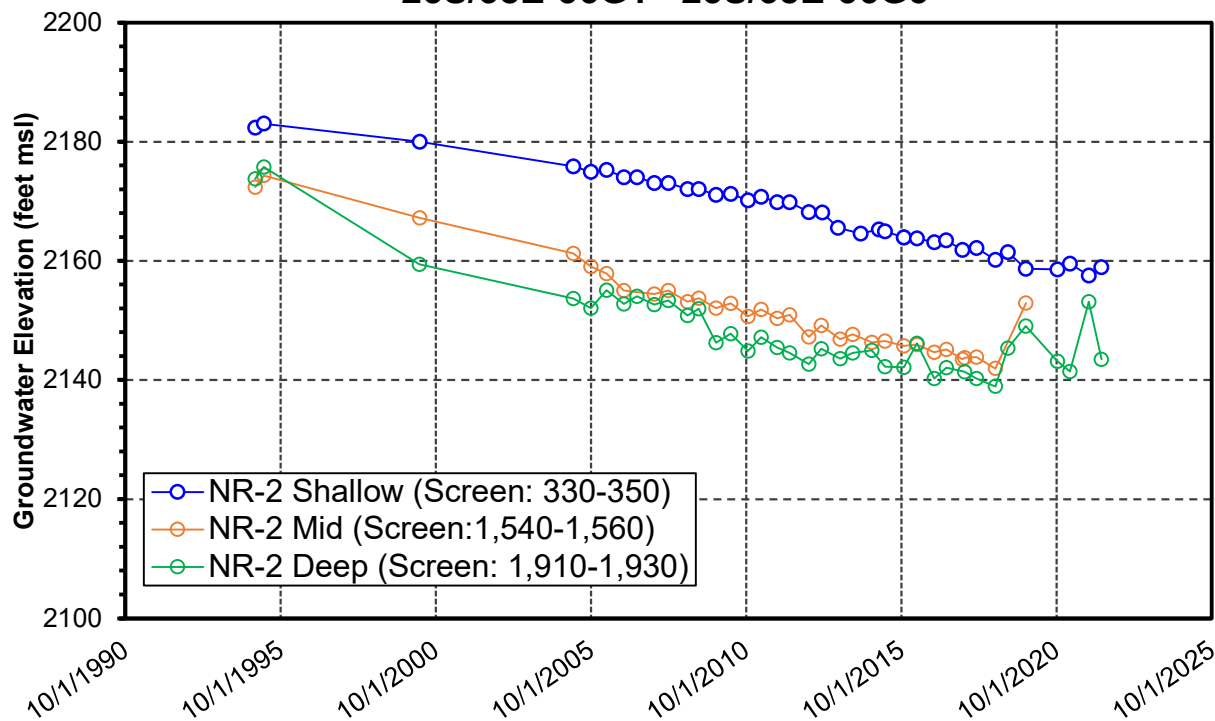

Sandquist Spa (2307 ft, msl)
Representative Monitoring Site
26S/39E-11E02

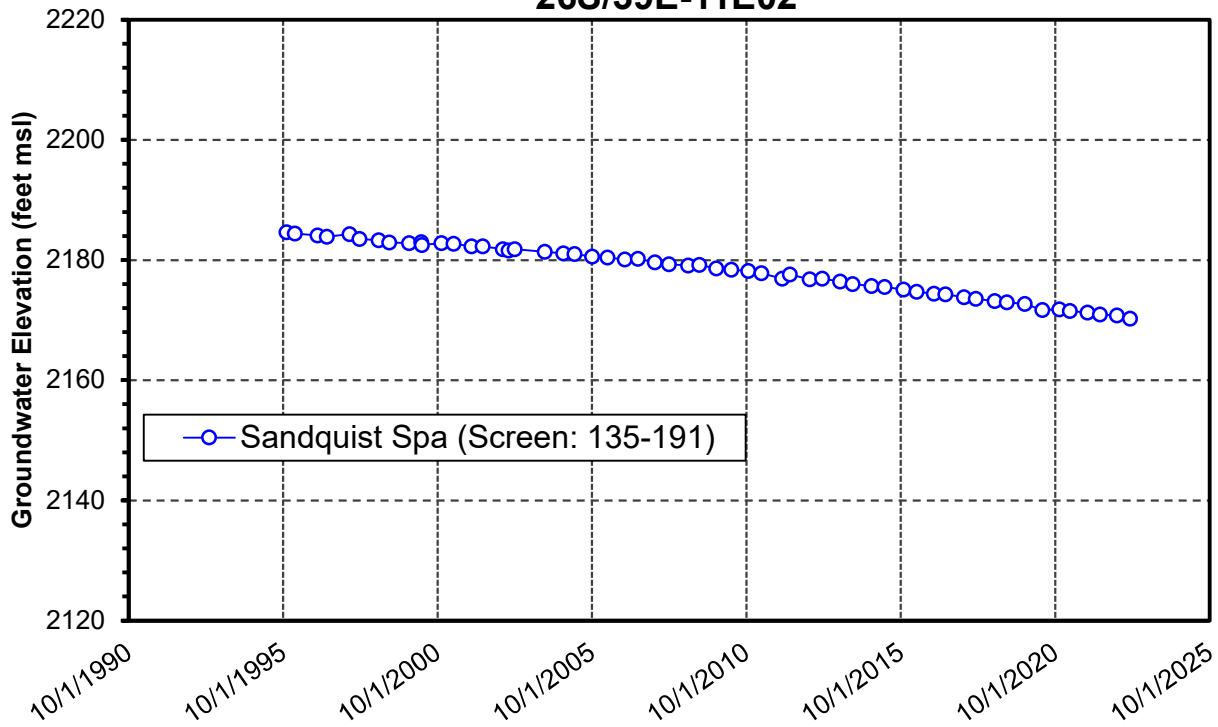

Kerr McGee 17 (2357 ft, msl)
Representative Monitoring Site
26S/39E-17G02

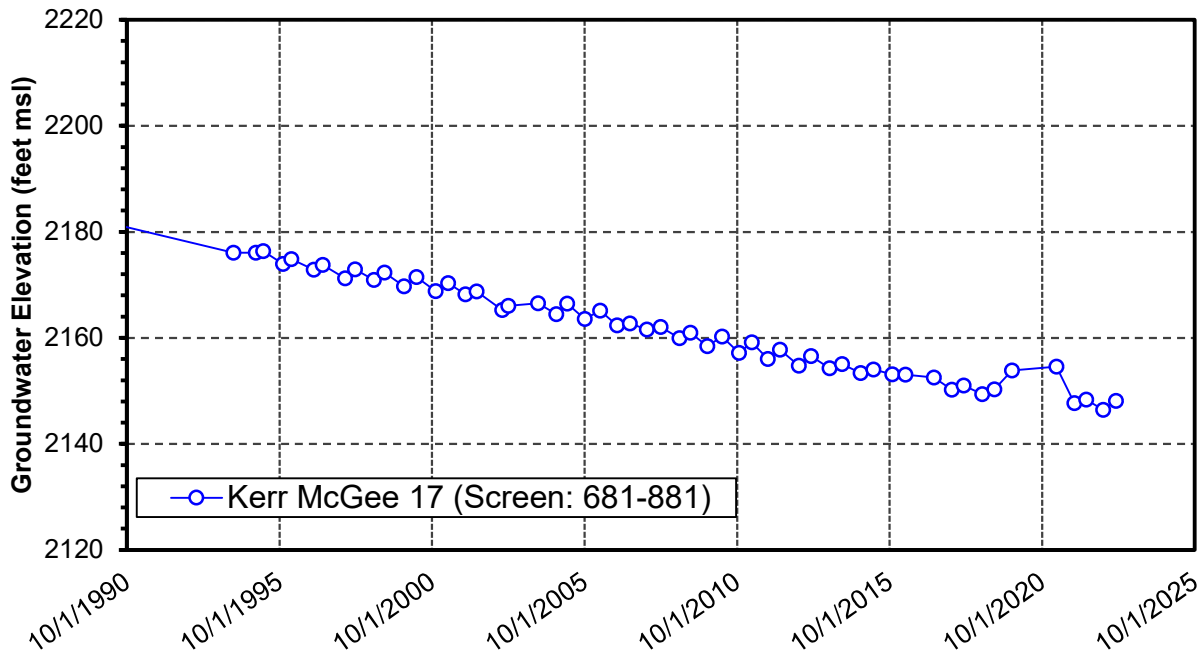

MW-32 (2419 ft, msl)
Representative Monitoring Site
26S/39E-27D02

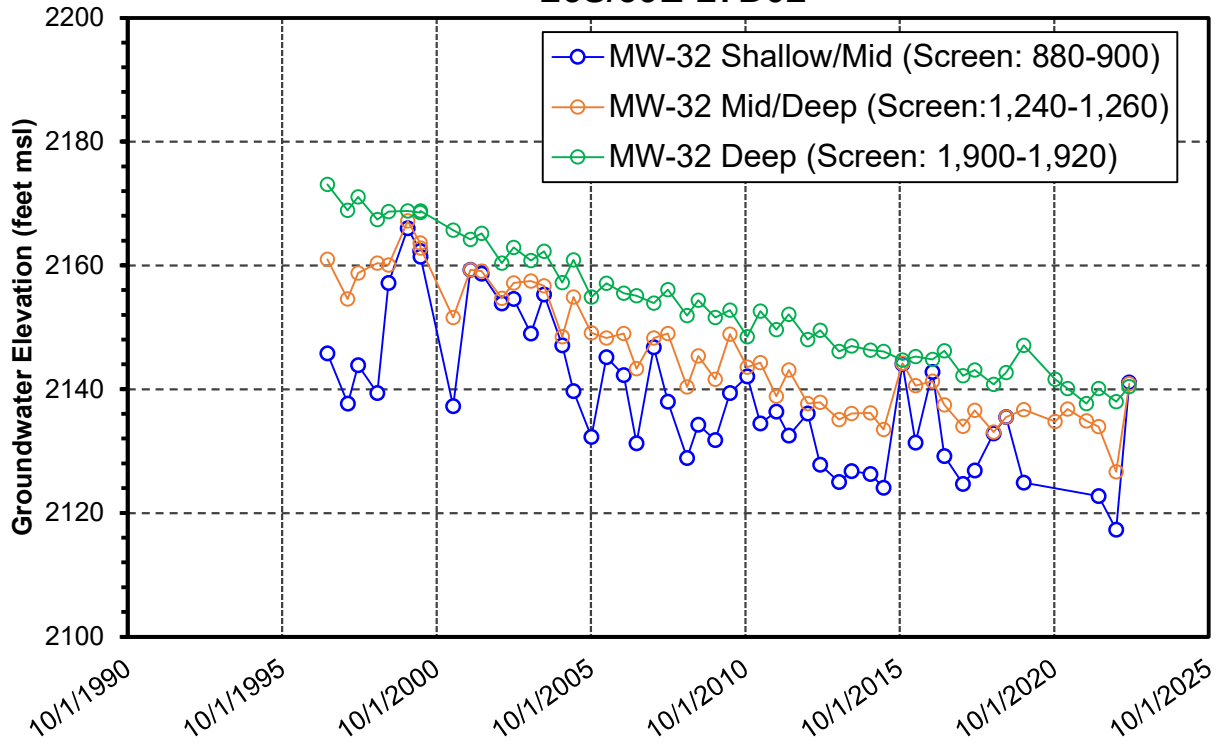

USBR 04 (2377 ft, msl)
Representative Monitoring Site
26S/39E-26A03

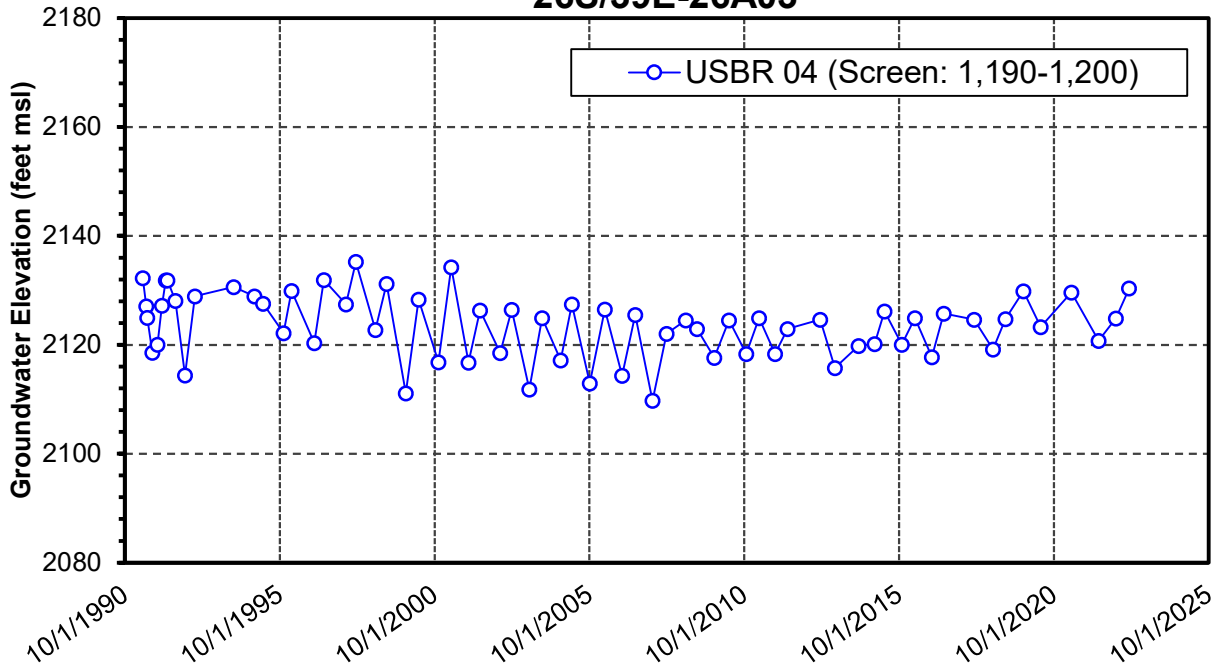

26S/39E-32L1 (2492 ft, msl)

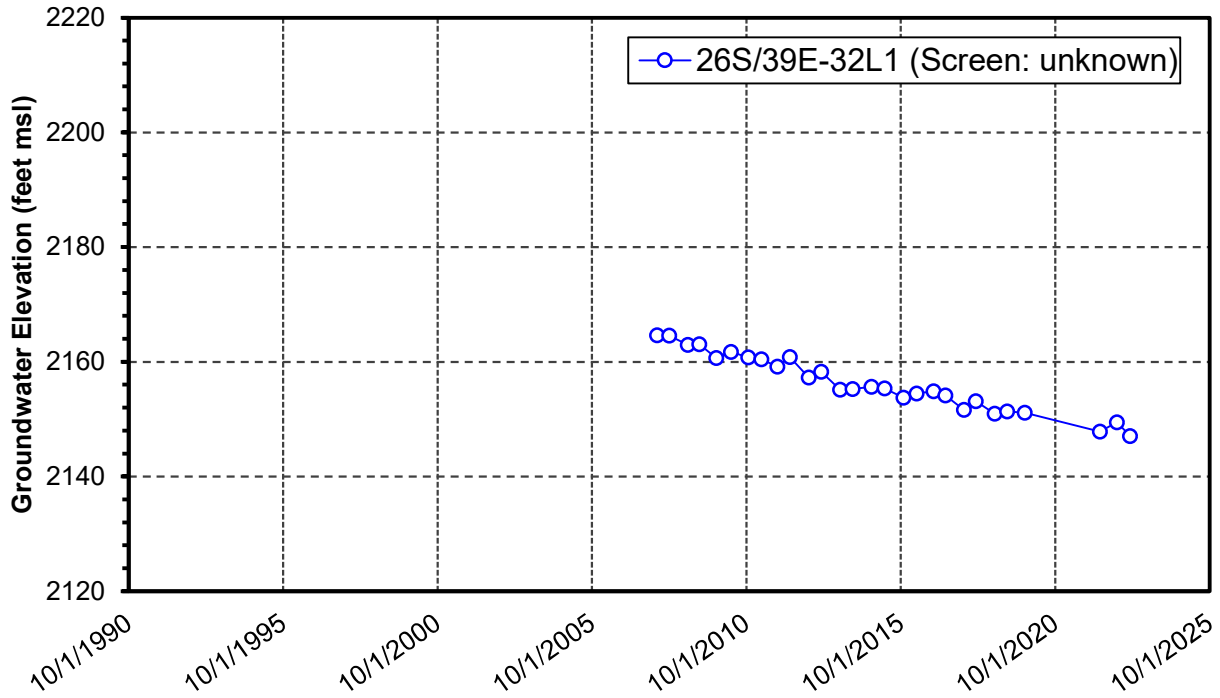

George Air Corridor (2322.64 ft, msl) Representative Monitoring Site 27S/40E-01K02

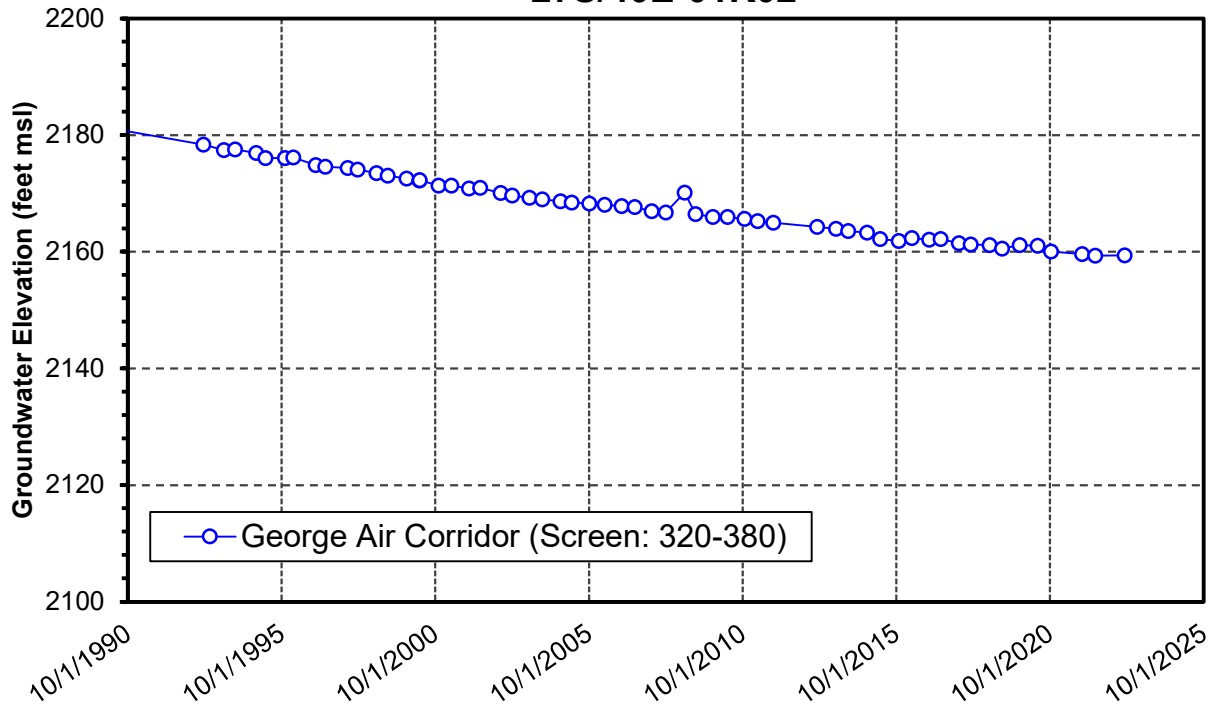

USBR 03 (2510 ft, msl)
Representative Monitoring Site
27S/39E-11D1 - 27S/39E-11D3

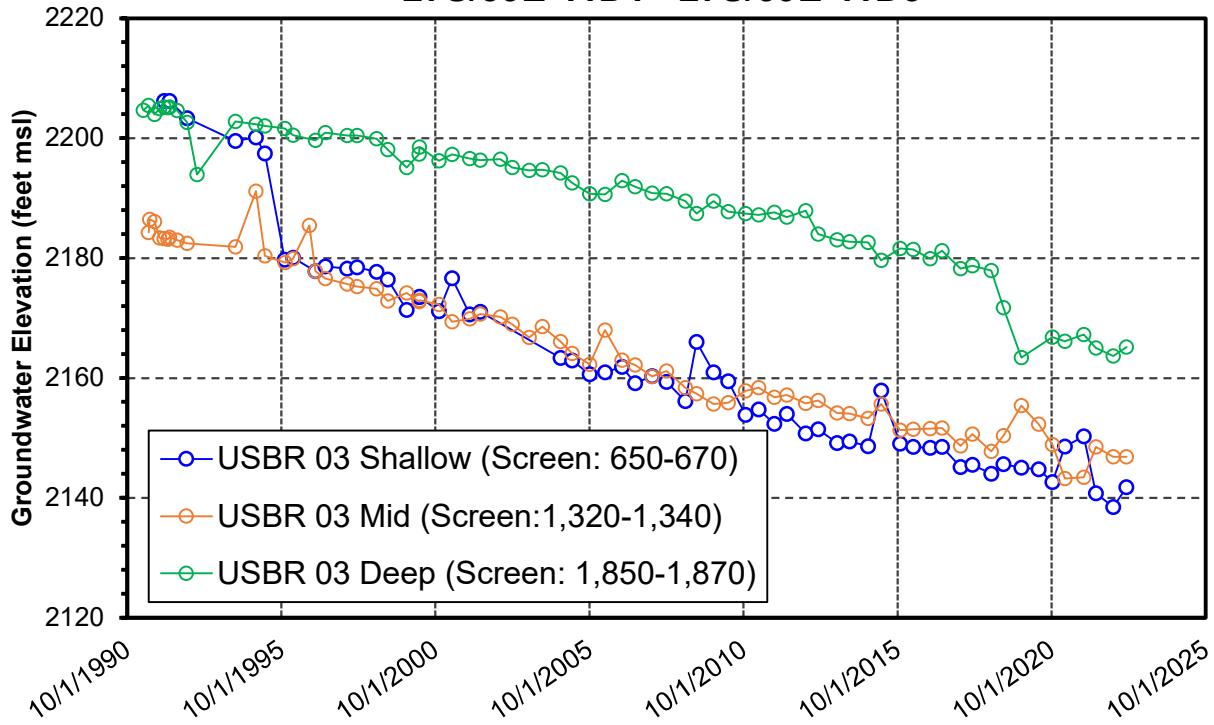

Inyo Well (2564 ft, msl)
Representative Monitoring Site
27S/39E-07R1

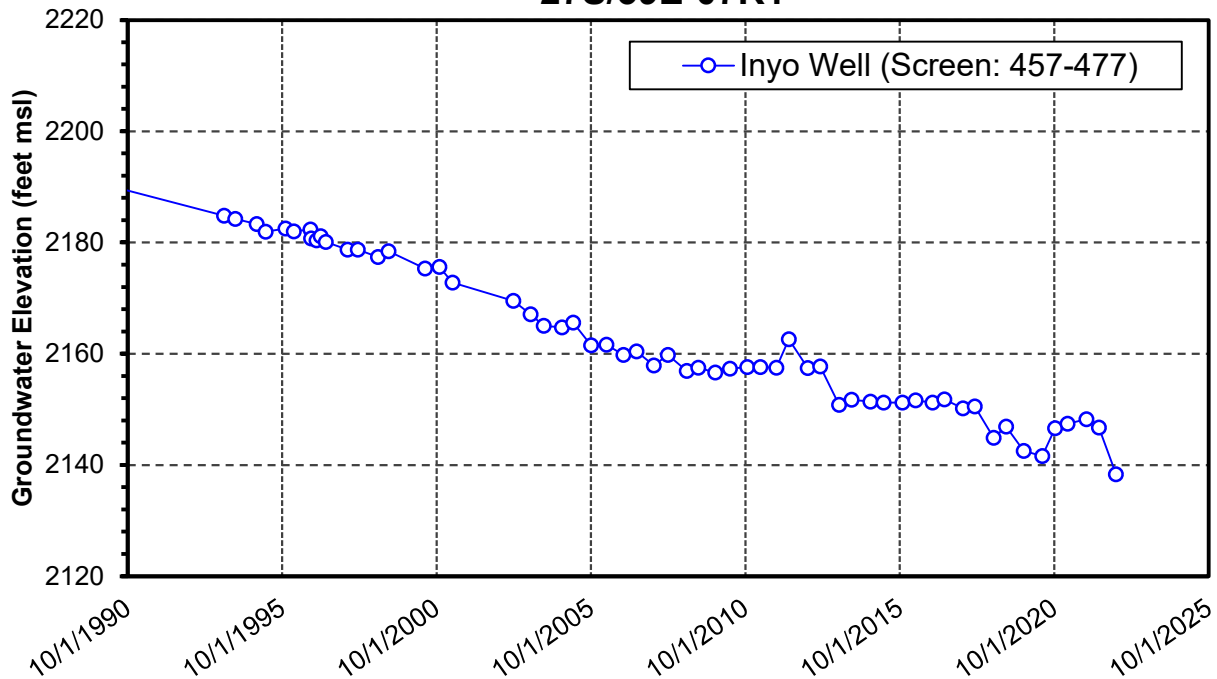

**AB303-05 (3024 ft, msl)
27S/38E-21L1**

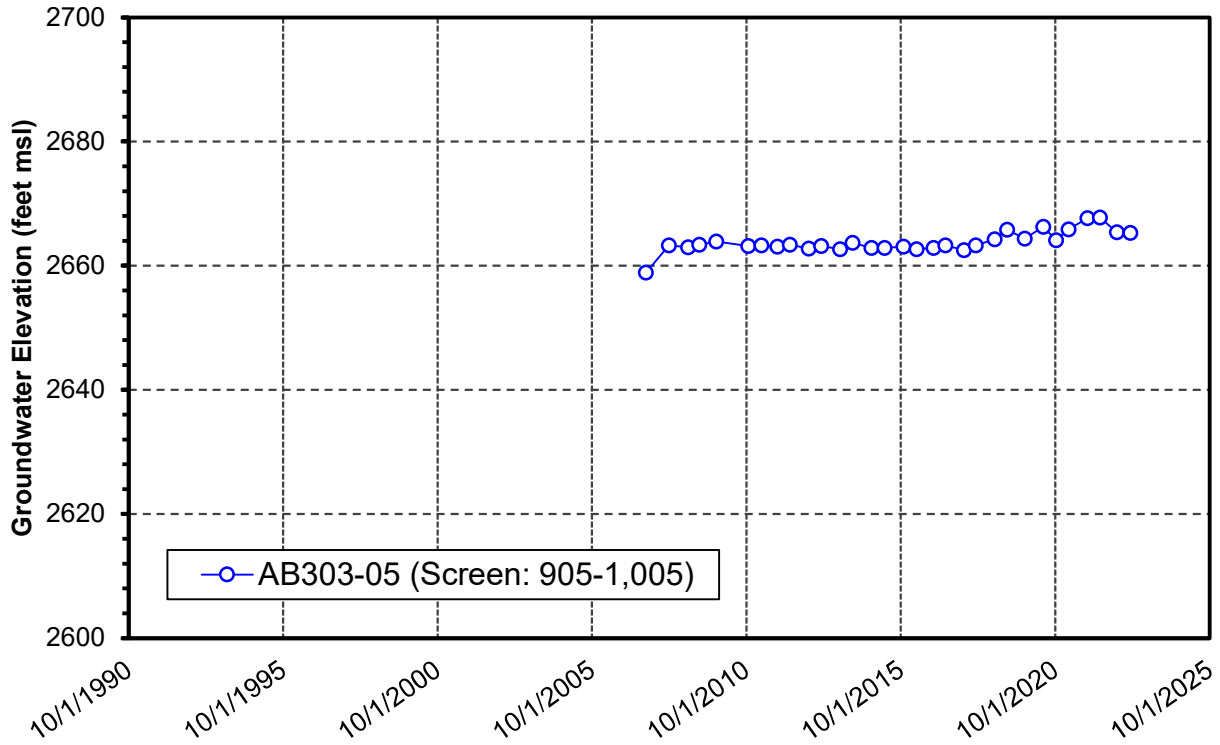

**USBR 01 (2851 ft, msl)
Representative Monitoring Site
27S/38E-23F1 - 27S/38E-23F4**

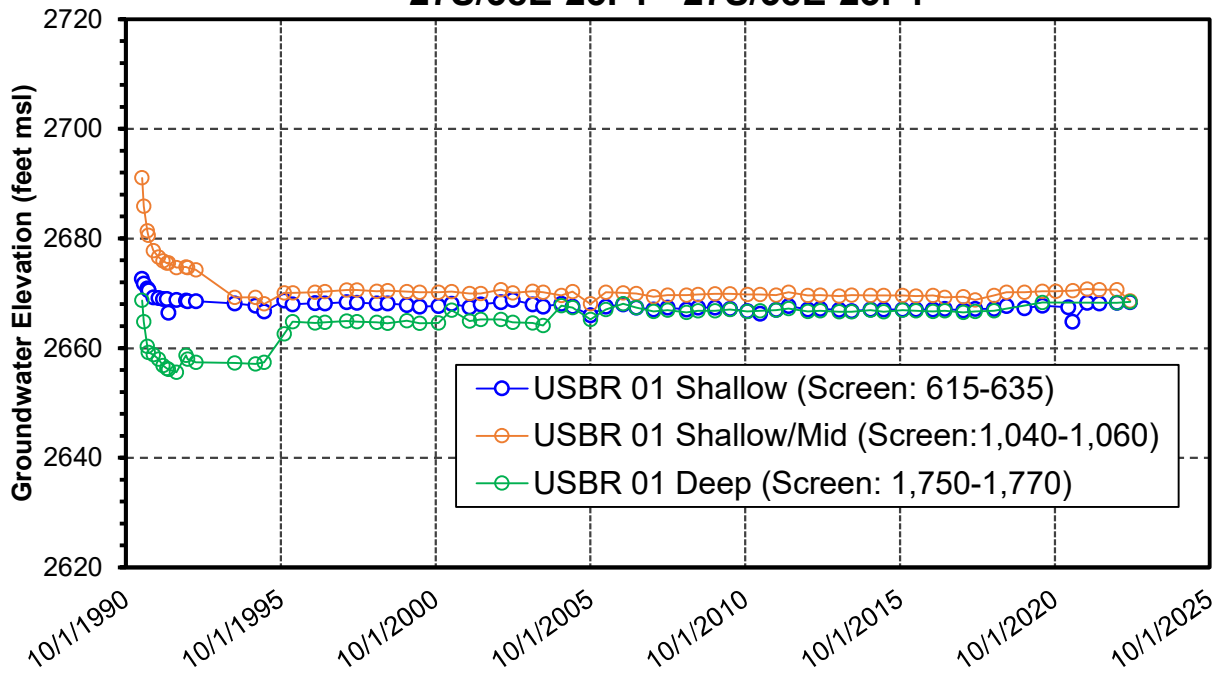

Attachment F

Storage Change Estimate Using Thiessen Polygon Method

INDIAN WELLS VALLEY GROUNDWATER BASIN
ESTIMATED GROUNDWATER STORAGE CHANGE

Note: This Storage Change Calculation is for Measured Areas of the IWV Basin

Polygon	State ID			Basin	Specific Yield	Surface Area (acres)	Groundwater Level (Feet, msl)							Change (feet)						Storage Change (AF) for Measured Area of IWV Basin							
	T/R-S	Common Name	Area				2015	2016	2017	2018	2019	2022	2023	2015-2016	2016-2017	2017-2018	2018-2019	2019-2022	2022-2023	WY 2016	WY 2017	WY 2018	WY 2019	2020 to 2022		WY 2023	4-Yr Cumm
							2020	2021	3-year Avg	2022	2023	2023															
1	28S/38E-18R	Black Hills Well	EP	0.21	14,609	2,820	2,820	2,820	2,821	2,820	2,820	2,820	0.1	0.2	0.6	-0.4	-0.3	0.0	307	614	1,841	-1,227	-918	-306	0	-918	
2	27S/38E-27M01	USNS-03	EP	0.21	2,987	2,679	2,679	2,679	2,679	2,680	2,681	2,680	-0.1	0.2	-0.2	1.2	0.6	0.2	-63	126	-126	753	376	125	138	514	
3	27S/38E-23F01	USBR 1-S	EP	0.08	1,967	2,667	2,667	2,667	2,668	2,668	2,668	2,668	0.0	0.1	0.0	0.5	0.5	0.2	0	16	0	79	77	26	32	109	
4	27S/38E-21L01	AB303-05	EP	0.21	5,344	2,663	2,663	2,663	2,663	2,666	2,668	2,665	-0.2	0.6	0.0	2.5	2.0	-2.5	-225	673	0	2,806	2,245	748	-2,806	-561	
5	27S/38E-15R01	AB303-06	EP	0.21	1,497	2,659	2,658	2,658	2,659	2,659	2,659	2,659	-0.6	-0.1	0.6	0.6	-0.2	-0.8	-189	-31	189	189	-63	-21	-251	-314	
6	27S/38E-09P01	Father Crowley	EP	0.21	849	2,694	2,694	2,695	2,695	2,694	2,697	2,691	0.3	0.2	0.1	-0.7	2.5	-5.2	54	36	18	-125	446	149	-933	-487	
7	27S/38E-08R01		EP	0.21	3,525	2,697	2,697	2,697	2,697	2,696	2,701	2,701	0.3	0.0	0.0	-1.0	4.3	0.2	222	0	0	-740	3,183	1,061	170	3,354	
8	27S/38E-10B02	AB303-03	EP	0.21	1,588	2,469	2,470	2,470	2,469	2,469	2,473	2,470	0.5	0.6	-1.0	-0.1	3.4	-3.1	167	200	-333	-33	1,134	378	-1,034	100	
9	27S/38E-09C01	AB303-04	EP	0.21	1,645	2,689	2,689	2,689	2,689	2,689	2,691	2,689	0.4	0.1	-0.6	0.2	2.0	-2.4	138	35	-207	69	691	230	-829	-138	
10	27S/39E-19E01	IWV MW #3	IWV	0.08	2,275	2,436	2,435	2,436	2,435	2,435	2,435	2,435	-0.2	0.1	-0.4	0.2	-0.4	-0.1	-36	18	-73	36	-72	-24	-18	-91	
11	27S/38E-13A01	Sea Bee Well	IWV	0.08	1,517	2,430	2,430	2,430	2,430	2,429	2,429	2,429	0.0	-0.2	-0.2	0.2	-0.9	0.1	0	-24	-24	24	-107	-36	11	-96	
12	27S/39E-08P02	IWV MW # 2	IWV	0.21	3,341	2,150	2,149	2,149	2,147	2,146	2,145	2,139	-0.8	-0.2	-1.5	-1.0	-1.2	-6.3	-561	-140	-1,053	-702	-845	-282	-4,420	-5,265	
13	27S/39E-07R01	Inyo	IWV	0.21	631	2,151	2,152	2,152	2,151	2,147	2,147	2,145	0.4	0.2	-1.3	-3.6	-0.2	-1.5	53	27	-172	-477	-27	-9	-199	-225	
14	27S/39E-08M02	IWV MW #1	IWV	0.21	468	2,148	2,147	2,146	2,146	2,144	2,140	2,136	-0.7	-0.7	-0.7	-1.9	-3.4	-4.4	-69	-69	-69	-187	-334	-111	-433	-767	
15	27S/39E-11D01	USBR 3-S	IWV	0.08	5,027	2,158	2,149	2,149	2,146	2,146	2,141	2,142	1.8	-0.2	-2.5	-7.0	-4.8	1.0	724	-80	-1,005	-2,815	-1,947	-649	394	-1,552	
16	27S/40E-06N02		IWV	0.08	4,727	2,119	2,121	2,119	2,122	2,121	2,123	2,125	2.1	-1.6	2.7	-1.4	2.6	1.8	794	-605	1,021	-530	997	332	666	1,663	
17	27S/40E-01K02	George Air Corr.	IWV	0.21	1,001	2,162	2,162	2,162	2,161	2,161	2,159	2,159	0.2	-0.2	-0.9	-0.7	-1.2	0.0	42	-42	-189	-147	-253	-84	8	-245	
18	27S/40E-06E01		IWV	0.08	975	2,114	2,116	2,115	2,115	2,116	2,119	2,122	1.7	-1.1	0.9	0.4	3.6	2.1	133	-86	70	31	279	93	166	445	
19	27S/39E-04C01		IWV	0.21	1,116	2,158	2,157	2,157	2,157	2,154	2,150	2,149	-0.7	-0.5	-0.2	-2.4	-4.3	-0.5	-164	-117	-47	-563	-1,003	-334	-122	-1,125	
20	27S/38E-02C01	USBR 2-S	IWV	0.21	1,109	2,373	2,373	2,373	2,372	2,372	2,373	2,373	-0.2	0.5	-1.0	0.0	1.1	0.0	-47	117	-233	0	256	85	-1	256	
21	26S/39E-34R02		IWV	0.21	1,379	2,136	2,135	2,134	2,133	2,132	2,128	2,127	-0.8	-1.1	-1.1	-1.1	-3.7	-0.7	-232	-319	-319	-319	-1,074	-358	-200	-1,274	
22	26S/40E-31K01		IWV	0.21	1,791	2,113	2,115	2,114	2,115	2,118	2,119	2,119	2.2	-0.7	0.4	2.9	1.4	0.0	828	-263	151	1,091	530	177	1	530	
23	26S/39E-32L01		IWV	0.21	3,171	2,155	2,154	2,154	2,153	2,151	2,148	2,147	-0.9	-0.3	-1.0	-1.8	3.5	-0.8	-599	-200	-666	-1,199	-2,338	-779	-526	-2,864	
24	26S/39E-31R03		IWV	0.21	1,376	2,144	2,144	2,144	2,142	2,141	2,138	2,136	-0.5	-0.4	-1.2	-1.4	-3.1	-1.1	-130	-130	-347	-404	-893	-298	-315	-1,208	
25	26S/40E-35H02	Satellite Lake2(e)	IWV	0.21	2,609	2,155	2,154	2,154	2,153	2,153	2,154	2,154	-0.4	-0.3	-0.7	-0.3	0.8	-0.4	-219	-164	-384	-164	449	150	-225	224	
26	26S/39E-26P02		IWV	0.18	1,070	2,146	2,146	2,145	2,144	2,143	2,140	2,140	-0.6	-0.6	-0.9	-1.4	-2.7	-0.2	-116	-116	-173	-270	-514	-171	-44	-558	
27	26S/39E-27D04	MW 32-D	IWV	0.18	1,459	2,146	2,145	2,146	2,143	2,143	2,140	2,140	-0.8	0.9	-3.1	-0.4	-2.6	0.3	-210	236	-814	-105	-684	-228	89	-594	
28	26S/39E-26A03	USBR 4	IWV	0.18	1,694	2,126	2,125	2,126	2,125	2,125	2,121	2,130	-1.2	0.8	-1.1	0.1	-4.0	9.6	-366	244	-336	31	-1,219	-406	2,943	1,724	
29	26S/40E-22P04	PW Substation 2	IWV	0.21	705	2,187	2,195	2,192	2,191	2,193	2,206	2,206	7.5	-2.5	-0.8	1.2	13.3	0.0	1,110	-370	-118	178	1,970	657	-6	1,964	
30	26S/40E-19N02		IWV	0.21	448	2,129	2,129	2,129	2,130	2,132	2,129	2,130	-0.3	0.2	1.4	1.4	-2.8	0.8	-28	19	132	132	-266	-89	75	-191	
31	26S/40E-21K03		IWV	0.21	706	2,164	2,165	2,166	2,164	2,165	2,167	2,168	1.1	0.5	-1.9	1.2	2.0	0.6	163	74	-274	174	295	98	94	388	
32	26S/40E-20L01		IWV	0.21	812	2,151	2,150	2,151	2,151	2,151	2,151	2,151	-0.1	0.4	-0.1	0.1	-0.2	0.1	-17	68	-14	21	-36	-12	10	-25	
33	26S/40E-22H03		IWV	0.21	2,397	2,197	2,196	2,196	2,195	2,195	2,195	2,195	-0.6	-0.3	-0.7	-0.4	0.3	0.3	-302	-151	-337	-222	150	50	131	281	
34	26S/39E-20C02		IWV	0.18	1,025	2,157	2,156	2,156	2,154	2,153	2,150	2,150	-0.8	-0.5	-1.5	-1.0	-3.2	-0.7	-148	-92	-277	-185	-591	-197	-129	-720	
35	26S/39E-13R04		IWV	0.21	1,793	2,129	2,126	2,126	2,128	2,130	2,125	2,128	-3.4	0.3	1.8	2.0	-5.1	2.9	-1,280	113	689	738	-1,911	-637	1,085	-827	
36	26S/40E-17N01		IWV	0.21	1,039	2,151	2,151	2,152	2,152	2,152	2,152	2,152	0.0	0.4	0.1	0.2	0.1	0.0	0	87	31	52	13	4	9	22	
37	26S/40E-15N01		IWV	0.21	2,894	2,187	2,187	2,187	2,187	2,187	2,187	2,186	-0.3	0.3	-0.3	0.0	-0.2	-0.2	-182	182	-176	24	-104	-35	-134	-238	
38	26S/39E-15J		IWV	0.18	1,688	2,148	2,146	2,147	2,145	2,145	2,144	2,144	-1.9	0.5	-1.2	-0.4	-0.8	0.2	-577	152	-365	-137	-231	-77	49	-182	
39	26S/39E-14E01		IWV	0.21	864	2,169	2,169	2,168	2,168	2,167	2,165	2,165	-0.4	-0.9	-0.2	-0.6	-1.9	-0.6	-73	-163	-38	-103	-346	-115	-102	-448	
40	26S/39E-17G02	Kerr McGee	IWV	0.18	1,957	2,154	2,153	2,153	2,151	2,150	2,148	2,148	-1.0	-0.5	-1.6	-0.7	-1.9	-0.3	-352	-176	-546	-247	-673	-224	-102	-775	
41	26S/39E-11E02	Sandquist Spa	IWV	0.21	987	2,176	2,175	2,174	2,174	2,173	2,171	2,170	-0.8	-0.4	-0.8	-0.6	-2.0	-0.7	-166	-83	-158	-122	-413	-138	-147	-560	
42	26S/39E-09E		IWV	0.21	1,733	2,146	2,145	2,145	2,143	2,143	2,142	2,142	-0.5	-0.4	-1.4	-0.4	-0.6	0.2	-182	-146	-521	-157	-234	-78	73	-161	
43	26S/40E-12C		IWV	0.21	8,284	2,162	2,162	2,162	2,161	2,162	2,160	2,161	-0.3	0.5	-0.6	0.4	-1.5	0.4	-522	870	-1,096	783	-2,644	-881	659	-1,986	
44	26S/39E-02N01		IWV	0.21	2,103	2,176	2,175	2,175	2,174	2,173	2,173	2,172	-0.7	-0.6	-0.6	-0.7	-0.8	-0.5	-309	-265	-269	-292	-333	-111	-234	-567	
45	26S/38E-02Q01		IWV	0.21	1,509	2,164	2,164	2,163	2,162	2,160	2,158	2,156	-0.6	-1.1	-0.9	-2.0	-3.6	-2.2	-190	-349	-285	-634	-1,141	-380	-689	-1,830	
46	26S/38E-01M05		IWV	0.21	1,520	2,167	2,166	2,165	2,164	2,163	2,161	2,160	-0.6	-0.6	-1.2	-1.2	-2.5	-0.5	-192	-192	-383	-383	-808	-269	-150	-958	
47	26S/39E-05F01		IWV	0.21	1,247	2,171	2,170	2,169	2,168	2,166	2,165	2,164	-1.0	-0.5	-0.9	-1.7	-1.5	-0.7	-262	-131	-236	-439	-384	-128	-178	-562	
48	26S/38E-02B01		IWV	0.21	519	2,166	2,166	2,165	2,164	2,162	2,157	2,159	-0.8	-0.6	-1.1	-2.2	-4.6	2.0	-87	-65	-120	-240	-497	-166	214	-284	
49	26S/39E-01A01		IWV	0.21	2,482	2,170	2,170	2,1																			

Note: This Storage Change Calculation is for Measured Areas of the IWV Basin

Polygon	State ID	Common Name	Basin	Specific Yield	Surface Area (acres)	Groundwater Level (Feet, msl)							Change (feet)					Storage Change (AF) for Measured Area of IWV Basin										
						2015	2016	2017	2018	2019	2022	2023	2015-2016	2016-2017	2017-2018	2018-2019	2019-2022	2022-2023	WY 2016	WY 2017	WY 2018	WY 2019	2020 to 2022		WY 2023	4-Yr Cumm		
																							3-year Avg	Anl				
56	25S/39E-28P01	Baker 4-NE	IWV	0.21	2,504	2,185	2,187	2,189	2,188	2,190	2,175	2,180	1.9	1.9	-0.2	1.3	-14.3	4.2	1,015	1,015	-89	673	-7,537	-2,512	2,224	-5,313		
57	25S/39E-29M01		IWV	0.21	2,556	2,177	2,177	2,176	2,176	2,175	2,173	2,173	-0.6	-0.5	-0.5	-0.6	-1.8	-0.5	-295	-268	-263	-333	-985	-328	-279	-1,264		
58	25S/38E-25I03	NR 1-D	IWV	0.21	1,475	2,158	2,158	2,157	2,156	2,155	2,143	2,142	-0.5	-0.7	-1.4	-0.8	-11.9	-0.5	-155	-217	-434	-248	-3,687	-1,229	-155	-3,842		
59	25S/38E-14Q01		IWV	0.21	3,621	2,163	2,168	2,167	2,166	2,165	2,163	2,165	4.8	-0.9	-0.9	-0.9	-2.5	2.5	3,650	-684	-684	-684	-1,878	-626	1,878	0		
60	25S/39E-12R01	Charely Tower	IWV	0.21	12,232	2,179	2,179	2,179	2,178	2,178	2,177	2,177	-0.2	-0.2	-0.2	-0.3	-0.7	-0.2	-591	-591	-591	-642	-1,923	-641	-514	-2,436		
61	25S/38E-12L03	USBR 6-D	IWV	0.21	6,289	2,190	2,189	2,189	2,188	2,187	2,187	2,186	-0.9	-0.4	-0.9	-0.6	-0.4	-0.7	-1,189	-528	-1,228	-753	-475	-158	-964	-1,440		
62	25S/39E-03R01	Baker Range	IWV	0.21	6,159	2,177	2,177	2,177	2,176	2,176	2,175	2,175	-0.4	-0.4	-0.3	-0.4	-1.0	-0.4	-474	-474	-414	-492	-1,304	-435	-466	-1,769		
63	24S/38E-21A04	USBR 10-D	IWV	0.21	4,060	2,244	2,244	2,243	2,243	2,241	2,242	2,240	-0.1	-0.9	-0.4	-1.1	0.1	-1.9	-85	-767	-341	-938	85	28	-1,586	-1,500		
64	25S/38E-03B		IWV	0.21	2,291	2,172	2,171	2,170	2,170	2,168	2,166	2,164	-0.9	-0.6	-0.4	-1.4	-2.5	-1.4	-433	-289	-193	-674	-1,202	-401	-664	-1,866		
65	25S/40E-30E01	TTBK MW14	IWV	0.21	6,169	2,177	2,177	2,177	2,177	2,177	2,176	2,176	-0.1	-0.1	-0.3	-0.2	-0.7	-0.2	-71	-71	-337	-259	-868	-289	-233	-1,101		
66	26S/38E-22B	Ostrich Ranch	IWV	0.21	2,465	2,240	2,240	2,236	2,236	2,240	2,237	2,233	-0.2	-4.0	-0.1	4.0	-2.6	-3.8	-104	-2,071	-52	2,071	-1,339	-446	-1,972	-3,311		
67	26S/38E-35B		IWV	0.21	1,714	2,233	2,231	2,232	2,233	2,232	2,232	2,232	-1.6	1.5	0.7	-1.0	-0.3	-0.3	-576	540	252	-360	-101	-34	-115	-216		
68	26S/38E-35D		IWV	0.21	1,869	2,238	2,238	2,238	2,238	2,237	2,239	2,236	0.1	0.1	-0.3	-0.5	1.7	-3.6	39	39	-118	-196	666	222	-1,413	-747		
69	26S/40E-28J01	Hospital	IWV	0.21	569	2,157	2,157	2,156	2,156	2,156	2,157	2,156	0.1	-0.7	-0.1	-0.6	1.0	-0.8	12	-84	-12	-72	120	40	-96	24		
70	26S/40E-29M01		IWV	0.21	2,837	2,124	2,130	2,130	2,127	2,131	2,124	2,125	6.4	0.0	-3.2	4.2	-7.7	1.1	3,813	0	-1,907	2,503	-4,562	-1,521	632	-3,930		
71	27S/38E-01C		IWV	0.08	1,268	2,200	2,199	2,199	2,199	2,199	2,196	2,195	-0.5	-0.3	-0.3	-0.3	-2.9	-0.6	-51	-30	-30	-30	-294	-98	-61	-355		
72	27S/39E-02K	Asphalt Constr	IWV	0.21	2,387	2,151	2,149	2,148	2,147	2,146	2,144	2,142	-1.4	-1.4	-1.4	-0.3	-0.9	-1.5	-711	-711	-711	-150	-451	-150	-750	-1,201		
73	27S/39E-08A01		IWV	0.21	1,190	2,148	2,148	2,147	2,147	2,145	2,139	2,137	0.2	-1.1	-0.5	-1.8	-5.7	-2.7	50	-275	-125	-450	-1,423	-474	-665	-2,088		
74	24S/38E-33I02		IWV	0.21	3,435	2,175	2,174	2,170	2,173	2,172	2,169	2,169	-1.0	-3.4	2.9	-1.1	-3.3	-0.9	-721	-2,453	2,092	-794	-2,381	-794	-632	-3,012		
75	25S/39E-22J01	S. Baker Ranch	IWV	0.21	3,600	2,179	2,178	2,178	2,178	2,177	2,176	2,176	-0.3	-0.3	-0.3	-0.4	-1.1	-0.3	-263	-263	-204	-280	-805	-268	-242	-1,047		
76	26S/40E-34F01	City of Ridgecrest	IWV	0.21	926	2,146	2,147	2,147	2,146	2,145	2,145	2,145	0.5	-0.4	-0.6	-0.5	-1.7	-0.1	97	-78	-107	-107	-321	-107	-17	-338		
77	27S/40E-02J01	DMP Cemetery	IWV	0.21	2,308	2,162	2,162	2,162	2,161	2,161	2,159	2,151	0.2	-0.2	-0.9	-0.7	-1.2	-8.8	97	-97	-436	-339	-584	-195	-4,259	-4,842		
					IWV Main Basin	154,960								IWV Main Basin							-4,791	-12,149	-17,486	-11,107	-47,648	-15,883	-12,370	-60,018
					El Paso Subarea	34,011								El Paso Subarea							412	1,667	1,381	1,770	7,171	2,390	-5,513	1,658
					188,971								Total for measured Area							-4,380	-10,482	-16,105	-9,338	-40,477	-13,492	-17,883	-58,360	
																				BN	AN	BN	W	AN_D_BN	W			

Notes:

Specific Yield values from Appendix 3-H GSP Model Documentation
red: field measurement not available, estimated from hydrograph

Attachment G

Estimated WY 2023 Groundwater Production

Attachment G: WY 2023 Groundwater Production Estimate

Water Use Sector (DWR)	Water User	No Action Baseline WY 2023		Reported Groundwater Pumping WY 2023		Estimated Groundwater Pumping WY 2023	
		note	(AFY)	note	(AFY)	note	(AFY)
Urban	IWVWD	2	6,628	1	4,266	3	5,443
Urban	City/County	2	425	1	35	3	173
Industrial	Searles Valley Minerals	2	2,907	1	2,514	3	2,575
Other - Federal	U.S. Navy	2	2,041	4	1,377	4	1,377
Agriculture	Meadowbrook Farms	2	12,303	1	3,642	1	3,642
Agriculture	Mojave Pistachio	2	6,891	1	3,523	1	3,523
Agriculture	Simmons Farm	2	931	1	0	1	0
Agriculture	Sierra Shadows	2	765	1	114	3	244
Agriculture	Quist Farms	2	685	1	272	3	489
Agriculture	Other Small Ag	2	957	1	151	3	211
Other - Co- Ops/Mutuals/Community Services District	Other - Co- Ops/Mutuals/Community Services District		544	1	150	3	634
Other - Domestic	Domestic	2	832		0	2	832
			35,909			19,141	

Notes:

- 1 Production reported to IWVGA for volumetric production fees and/or transient pool records. (Not all required pumpers report production.)
- 2 Estimated from GSP 'No Action' Baseline analysis.
- 3 Missing data estimated from best available data sources.
- 4 Data provided by Navy to the IWVGA via letter on November 7, 2023.

Attachment H

WY 2023 Water Quality Data

Table 1 Well Information, Sampling Methods, & Depth to Water Levels

State ID	Other Name	Latitude	Longitude	Well Type	Total Depth (ft, bgs)	Screen Interval (ft, bgs)	Sampling Method	Date	DTW	Sample Time
25S/38E-14A	Bork	35.76809	-117.85244	DOM	unk	unk	Owner purged	10/3/2022	234.91	10/3/2022 9:35
25S/38E-34A01	Means	35.72453	-117.87024	DOM	480	418.5-479.5	Owner purged	10/3/2022	365.83	10/3/2022 12:30
27S/38E-09C01	AB303-04	35.60665	-117.89378	MW	601	501-581	Hydrasleeve	10/3/2022	386.66	10/4/2022 8:22
27S/38E-13A02	AB303-01	35.59369	-117.8307	MW	690	232-272, 372-472, 630-690	Hydrasleeve	10/3/2022	225.81	10/4/2022 9:20
27S/38E-15R01	AB303-06	35.58195	-117.86617	MW	380	280-340	Hydrasleeve	10/3/2022	276.92	10/4/2022 9:45
27S/38E-21L01	AB303-05	35.56985	-117.89592	MW	1045	905-1005	Hydrasleeve	10/3/2022	360.49	10/4/2022 11:11
27S/39E-08A01	08A01	35.60721	-117.79818	MW	955	550-865, 895-935	Hydrasleeve	10/3/2022	397.98	10/4/2022 11:55
27S/40E-01K02	George Air Corridor	35.6147	-117.62469	MW	400	320-380	Hydrasleeve	10/3/2022	165.01	10/4/2022 12:45
27S/38E-32C01	EP-1-S	35.54904179	-117.9107061	MW	0	450-470	Hydrasleeve	10/4/2022	275.28	10/5/2022 17:50
27S/38E-10B02	AB303-03	35.60662	-117.87407	MW	872	452-552	Hydrasleeve	10/4/2022	431.44	10/5/2022 18:22
25S/38E-35B01	35B01	35.72509	-117.85286	MW	unk	200-298	Hydrasleeve	10/4/2022	240.95	10/5/2022 19:00
25S/38E-03B	03B1	35.79546	-117.87382	MW	360	300-360	Hydrasleeve	10/4/2022	294.11	10/5/2022 19:20
26S/39E-25K01	25K1	35.64041	-117.74023	MW	580	440-540	Hydrasleeve	10/4/2022	267.71	10/5/2022 20:00
26S/38E-01M05	Fields	35.70215	-117.84707	DOM	360	299-359	Owner purged	10/5/2022	216.41	10/5/2022 10:40
26S/38E-01L01	Well G	35.702013	-117.841337	DOM	unk	unk	Owner purged			10/5/2022 8:35
25S/39E-03R01	Baker Range	35.78412	-117.76257	MW,C	185	65-165	Hydrasleeve	10/3/2022	51.42	10/5/2022 7:50
25S/39E-12R01	Charley Tower	35.77039	-117.72496	MW	150	60-140	Hydrasleeve	10/3/2022	25.01	10/5/2022 8:25
26S/39E-05L01	05L01(S)	35.69973	-117.80355	MW	600	160-240	Hydrasleeve	10/3/2022	131.38	10/5/2022 9:50
26S/39E-17G02	Kerr McGee	35.67635	-117.80452	MW	881	681-881	Hydrasleeve	10/3/2022	210.1	10/5/2022 10:35
26S/39E-11E02	Sandquist Spa	35.68857	-117.75647	MW,C	191	135-191	Hydrasleeve	10/3/2022	136.51	10/5/2022 11:15
26S/39E-05K01	05K01(D)	35.69973	-117.80339	MW	605	565-585	Hydrasleeve	10/3/2022	129.39	10/5/2022 14:15
26S/40E-19N02	19N02	35.65413	-117.72147	MW	267	245-265	Hydrasleeve	10/3/2022	209	10/5/2022 14:50
26S/40E-22E01	26S/40E-22E01	35.66135	-117.66687	MW	651.5	531-631	Hydrasleeve	10/3/2022	98.87	10/5/2022 15:30
26S/40E-22E02	26S/40E-22E02	35.66132	-117.66633	MW	650	570-630	Hydrasleeve			10/5/2022 16:00

Well Type
 MW: Monitoring Well
 C: CASGEM Well
 DOM: Domestic

Table 2 Water Quality Summary

Sample ID	State ID	Sample Date	Sample Depth (ft bgs)	Specific Conductance (EC) (µmhos/cm)	Total Filterable Residue/TDS (mg/L)	Calculated TDS/EC (multiplier)	Total Hardness (as CaCO ₃) (mg/L)	Total Anions (meq/L)	Total Cations (meq/L)	% difference	Odor Threshold (TON)	Turbidity (NTU)	Total Alkalinity (CaCO ₃) (mg/L)	Bicarbonate HCO ₃ (mg/L)	Carbonate CO ₃ (mg/L)	pH (Lab) (pH Units)
Maximum Contaminant Level (MCL)				1,600	1,000	n/a	n/a	n/a	n/a	n/a	3	5	n/a	n/a	n/a	n/a
14A01	25S/38E-14A	10/3/2022	ubknown	700	430	0.61	250	7.6	7.75	2.0	1	0.57	250	300	ND	7.7
34A01	25S/38E-34A01	10/3/2022	418.5-478.5	870	520	0.60	300	10	10	2.1	1	0.59	420	510	ND	7.2
AB303-04	27S/38E-09C01	10/4/2022	557-560	490	290	0.59	65	4.78	5.20	8.4	1	33	100	120	ND	8.0
AB303-01	27S/38E-13A02	10/4/2022	397-400	460	300	0.65	110	4.53	4.56	0.63	1	0.33	130	160	ND	7.7
AB303-06	27S/38E-15R01	10/4/2022	297-300	390	240	0.62	56	3.64	4.16	13	1	0.2	100	120	ND	8.0
AB303-05	27S/38E-21L01	10/4/2022	952-955	260	160	0.62	ND	2.78	2.7	3.1	1	0.44	120	150	ND	9.0
08A01	27S/39E-08A01	10/4/2022	572-575	410	260	0.63	100	3.95	3.92	0.88	1	0.48	110	140	ND	7.5
George Air Corridor	27S/40E-01K02	10/4/2022	247-250	1900	1000	0.53	150	17.3	16.2	6.3	1	0.24	120	140	ND	8.0
EP-1-S	27S/38E-32C01	10/5/2022	457-460	390	250	0.64	69	4.09	4.19	2.4	1	0.22	160	190	ND	7.5
AB303-03	27S/38E-10B02	10/5/2022	497-500	250	160	0.64	190	2.57	6.41	85	1	41	97	35	41	9.5
35B01	25S/38E-35B01	10/5/2022	247-250	880	510	0.58	160	9.88	9.5	3.9	1	31	370	450	ND	7.7
03B1	25S/38E-03B	10/5/2022	347-350	930	580	0.62	370	10.6	10.2	3.2	1	1.3	370	450	ND	7.0
25K1	26S/39E-25K01	10/5/2022	497-500	420	260	0.62	110	3.93	4.3	9	1	0.18	110	130	ND	7.8
01M05	26S/38E-01M05	10/5/2022	299-359	880	530	0.60	190	8.94	8.81	1.4	1	0.33	160	190	ND	7.6
Well G	26S/38E-01L01	10/5/2022	ubknown	850	520	0.61	170	8.89	8.24	7.6	1	0.2	160	200	ND	7.7
Baker Range	25S/39E-03R01	10/5/2022	97-100	960	610	0.64	260	10.6	10.8	2.1	1	0.17	310	380	ND	7.6
Charley Tower	25S/39E-12R01	10/5/2022	117-120	1100	690	0.63	190	12.30	11.6	5.7	1	1.6	310	380	ND	7.5
05L01(S)	26S/39E-05L01	10/5/2022	197-200	8000	5100	0.64	ND	114	105	8.6	1	0.31	4500	1700	1900	9.8
Kerr McGee	26S/39E-17G02	10/5/2022	697-700	260	170	0.65	18	3.53	2.72	26	1	2.7	160	140	26	8.6
Sandquist Spa	26S/39E-11E02	10/5/2022	157-160	580	340	0.59	190	5.98	5.98	0.056	1	ND	140	170	ND	7.7
05K01(D)	26S/39E-05K01	10/5/2022	572-575	31000	19000	0.61	ND	497	523	5.2	5	0.48	20000	6700	8900	9.9
19N02	26S/40E-19N02	10/5/2022	252-255	250	180	0.72	30	2.68	2.79	3.8	2	1.2	120	150	ND	7.4
22E01	26S/40E-22E01	10/5/2022	557-560	2600	1600	0.62	ND	33	28.6	14	3	1.6	1200	1200	140	8.7
22E02	26S/40E-22E02	10/5/2022	597-600	1800	1300	0.72	400	20.7	20.4	1.2	2	0.26	400	480	ND	7.6

n/a - Non applicable to dataset

ND - Analyte not detected at or above the reporting limit

J - Detected below the Reporting Limit; reported concentration is estimated

Table 2 Water Quality Summary

Sample ID	State ID	Sample Date	Sample Depth (ft bgs)	Chloride (mg/L)	Fluoride (mg/L)	Hydroxide (mg/L)	MBAS (LAS Mole. Wt 340.0) (mg/L)	Nitrate as N (mg/L)	Sulfate (mg/L)	Arsenic (µg/L)	Boron (µg/L)	Calcium (mg/L)	Copper (µg/L)	Iron (µg/L)	Magnesium (mg/L)	Manganese (µg/L)	Potassium (mg/L)	Sodium (mg/L)	Zinc (µg/L)
Maximum Contaminant Level (MCL)				500	2	n/a	0.5	10	500	10	n/a	n/a	1,000	300	n/a	50	n/a	n/a	5,000
14A01	25S/38E-14A	10/3/2022	ubknown	28	0.80	ND	0.048 ^J	1.9	89	3.3	250	64	12 ^J	200	21	ND	8.4	60	57
34A01	25S/38E-34A01	10/3/2022	418.5-478.5	14	0.61	ND	ND	0.39 ^J	63	6.3	480	77	36 ^J	21 ^J	27	0.83 ^J	6.6	84	59
AB303-04	27S/38E-09C01	10/4/2022	557-560	18	0.29	ND	ND	1.8	110	1.3 ^J	120	21	8.4 ^J	830	3	35	2.8	88	ND
AB303-01	27S/38E-13A02	10/4/2022	397-400	24	0.88	ND	ND	2.3	57	1.9 ^J	270	37	ND	ND	4.9	ND	1.8	52	ND
AB303-06	27S/38E-15R01	10/4/2022	297-300	11	0.27	ND	0.054 ^J	2.7	65	3.7	110	19	ND	ND	1.9	ND	2	69	ND
AB303-05	27S/38E-21L01	10/4/2022	952-955	2.6	0.40	ND	ND	0.13 ^J	11	5.2	100	1.5	ND	ND	ND	2.8 ^J	0.56 ^J	60	ND
08A01	27S/39E-08A01	10/4/2022	572-575	24	0.81	ND	ND	1.7	45	2.4	330	32	ND	120	5.3	21	2.1	42	ND
George Air Corridor	27S/40E-01K02	10/4/2022	247-250	490	1.9	ND	0.053 ^J	0.29 ^J	51	44	2800	50	ND	44 ^J	5.2	5.3	9.5	300	ND
EP-1-S	27S/38E-32C01	10/5/2022	457-460	15	0.64	ND	0.048 ^J	0.74	25	4.8	280	22	ND	ND	3.1	9.8 ^J	2.1	64	ND
AB303-03	27S/38E-10B02	10/5/2022	497-500	4.9	0.36	ND	ND	0.15 ^J	23	13	110	76	9.1 ^J	670	0.72 ^J	300	1	58	ND
35B01	25S/38E-35B01	10/5/2022	247-250	44	0.57	ND	ND	0.14 ^J	59	5.6	1100	44	ND	3600	13	180	5.3	140	ND
03B1	25S/38E-03B	10/5/2022	347-350	23	0.76	ND	ND	1.2	120	5.1	180	87	7.0 ^J	ND	36	ND	7.1	63	ND
25K1	26S/39E-25K01	10/5/2022	497-500	29	0.45	ND	0.051 ^J	3.0	46	4.7	250	34	ND	ND	4.8	ND	2.9	49	ND
01M05	26S/38E-01M05	10/5/2022	299-359	80	0.57	ND	ND	0.59	170	1.4 ^J	700	57	15 ^J	ND	13	1.1 ^J	4.1	110	ND
Well G	26S/38E-01L01	10/5/2022	ubknown	80	0.42	ND	ND	0.30 ^J	160	1.4 ^J	820	49	ND	23 ^J	11	0.99 ^J	3.8	110	ND
Baker Range	25S/39E-03R01	10/5/2022	97-100	50	0.73	ND	0.049 ^J	1.10	140	15	1400	45	7.6 ^J	ND	36	ND	15	120	ND
Charley Tower	25S/39E-12R01	10/5/2022	117-120	110	0.77	ND	0.065 ^J	0.29 ^J	140	15	2900	37	ND	180	24	24	15	170	ND
05L01(S)	26S/39E-05L01	10/5/2022	197-200	760	6.2	ND	0.24	ND	75	5.7	89000	4.1 ^J	ND	ND	ND	ND	15 ^J	2400	ND
Kerr McGee	26S/39E-17G02	10/5/2022	697-700	6	2.60	ND	ND	ND	3	4.7	560	5.7	ND	310	0.94 ^J	24	3.8	52	ND
Sandquist Spa	26S/39E-11E02	10/5/2022	157-160	62	0.55	ND	ND	1.9	68	1.7 ^J	310	61	ND	ND	8.9	ND	2.7	49	ND
05K01(D)	26S/39E-05K01	10/5/2022	572-575	3200	ND	ND	0.85	0.15 ^J	0.74	7.5	500000	ND	ND	ND	ND	ND	42 ^J	12000	ND
19N02	26S/40E-19N02	10/5/2022	252-255	6.0	0.77	ND	0.070 ^J	ND	0.72	1.7 ^J	220	9.5	ND	14 ^J	1.6	6.0 ^J	8.8	45	ND
22E01	26S/40E-22E01	10/5/2022	557-560	280	7.1	ND	0.070 ^J	0.15 ^J	21	3.1	23000	3.0 ^J	ND	ND	ND	9.4 ^J	7.8 ^J	650	ND
22E02	26S/40E-22E02	10/5/2022	597-600	19	3.8	ND	0.083 ^J	ND	580	330	2300	70	8.8 ^J	ND	54	24	29	270	ND

n/a - Non applicable to dataset

ND - Analyte not detected at or above the reporting limit

J - Detected below the Reporting Limit; reported concentration is estimated

Attachment I

IWV Model Configuration Item List

IWV-MODEL CONFIGURATION ITEM (CI) LIST

CI Request Number	CI Request Date	CI Summary	Importance Rank 1 (low) 5 (high)	Priority 1 (low) 5 (high)	Origin of CI (IWVGA, TAC, Navy, etc.)	Date Complete <i>review order</i>
1	10/27/22	Discussing changes to groundwater in storage and compare the model results to a Thiessen Polygon method.			TMG	TMG 12/15/22 Group discussion
2	1/19/23	Dr. Ryan Smith a. Discussion of how to approach AEM data analysis (SkyTEM Survey Data Report) b. Additional data to provide for AEM interpretation			TMG	TMG 2/14/23 Group discussion
3	3/23/23	DRI to present the first proposed GSP Model changes: a. Simulation period: October 1, 1920 through September 30, 2022. b. Stress period: annual stress period from October 1, 1920 to September 30, 1995; monthly stress period from October 1, 1995 to September 30, 2022. c. Six model layers d. Depth and thickness of each model layer based on Monasttero et al. (2002); Shah et al. (2018) and AEM data (2019) e. Hydraulic conductivity f. Pumping g. Recharge	5	5	TMG	TMG 8/17/23 Group discussion
4	5/24/23	Group meeting a. Seismic depth to basement analysis b. Clay plug analysis			TMG	TMG 5/24/23 Group discussion
5	6/14/23	Group meeting a. Depth to basement analysis b. Sedimentary thickness analysis			TMG	TMG 6/14/23 Group discussion
6	6/30/23	Group meeting a. Preliminary model layer delineation			TMG	TMG 6/30/23 Group discussion
7	7/21/23	a. Discussed methodology for discretizing model grid in basalt flow area below Rose Valley, and planned to delineate an aquifer property zone for the White Hills formation. b. DRI will continue work on model grid discretization using SkyTEM and well log data. DRI will complete the preliminary model discretization, define faults to be simulated, and analyze clay fraction in the clay plug to present at the next modeling group meeting.			TMG	TMG 7/21/23 Group discussion
8	9/25/23	Steve Bacon, September 25, 2023. Development of a Tectonic Block Model in Support of the Hydrogeology Conceptual Framework of IWV (2025 GSP Update)	5	5	TMG	TMG 9/25/23 Plan outside AEM review

Attachment J

WY 2023 Precipitation and Stream Gage Data



DRAFT MEMORANDUM

785 Grand Avenue, Suite 202 • Carlsbad, California • 94901
TEL: (760) 730-0701 FAX: (415) 457-1638 e-mail: stever@stetsonengineers.com

TO: File DATE: November 22, 2023
FROM: Stetson Engineers Inc. JOB NO: 2652
RE: Chimney Peak Weather Station – Annual Report of Precipitation, Water Year 2023

This memorandum serves as an annual summary of station operation and reporting of approved data records associated with the Chimney Peak Weather Station. IWVGA operation of this station is done under legal agreement with the Bureau of Land Management to occupy and operate the station inside of the BLM Chimney Peak Fire Station property boundary.

SUMMARY OF STATION OPERATIONS AND DATA – WY 2023

During WY 2023, three site visits were made to conduct maintenance of the station, October 2022, March 2023, and September 2023. During the March 2023 site visit significant snow accumulation prevented visiting the site, however a visual inspection from outside the fire station was possible to determine that no adverse impacts had occurred as a result of snow accumulation. The September visit further verified that the station had operated without issue throughout the year.

Over the course of the water year 22.19 inches of precipitation was recorded at this station. Total precipitation may have been greater than this as much of the winter time precipitation was as snowfall. Tipping bucket rain gages as are employed at many of the weather station in the area will experience inefficiencies in capturing of precipitation as snowfall due to the design. The following graph shows the accumulated precipitation for Water Year 2023.

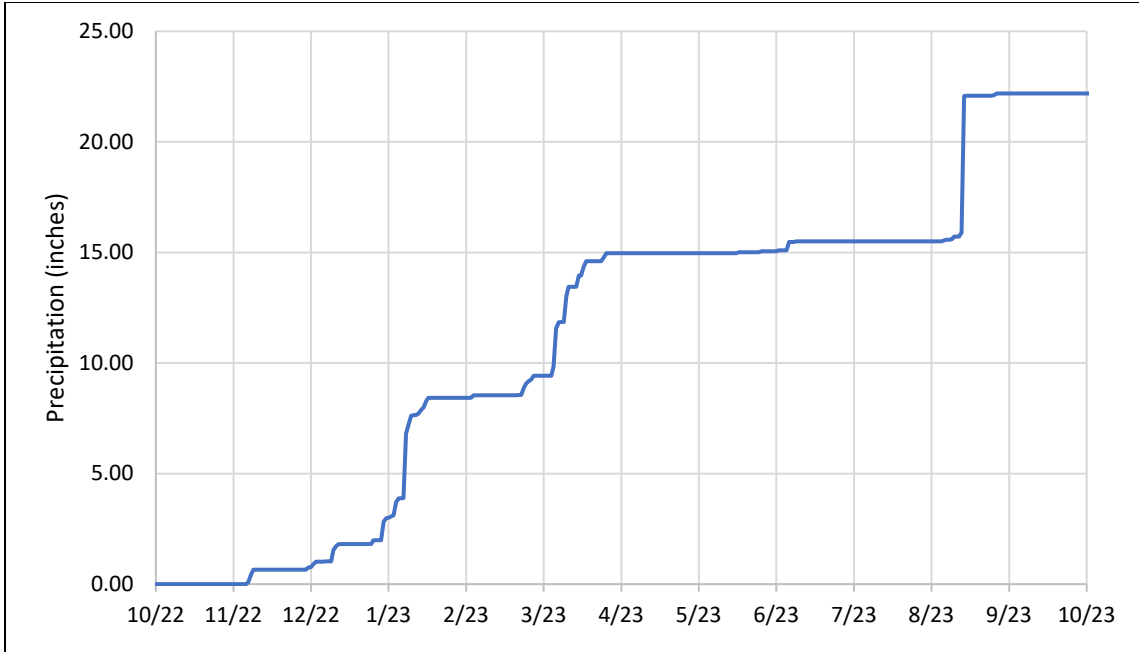

FIGURE 1. CUMULATIVE PRECIPITATION AT CHIMNEY PEAK WEATHER STATION WATER YEAR 2023

The following tables summarize the daily recorded precipitation totals, December 2020 through October 2023, by Water Year. Other parameter data is available on the IWVGSP.com website.

Daily Precipitation Data Chimney Peak Fire Station, Water Year 2021

Water year 2021
 Station Name Chimney Peak Fire Station
 Operating Agency IWVGA Agent - Stetson Engineers Inc.
 Latitude 35°52'08.5" N
 Longitude 118°00'42.6" W

DAY	Daily Precipitation (inches)											
	2020 OCT	NOV	DEC	2021 JAN	FEB	MAR	APR	MAY	JUN	JUL	AUG	SEP
1	---	---	---	0	0	0	0	0	0	0	0	0
2	---	---	---	0	0	0	0	0	0	0	0	0
3	---	---	---	0	0	0	0	0	0	0	0	0
4	---	---	---	0	0	0	0	0	0	0	0	0
5	---	---	---	0	0	0	0	0	0	0	0	0
6	---	---	---	0	0	0	0	0	0	0	0	0
7	---	---	---	0	0	0	0	0	0	0	0	0
8	---	---	---	0	0	0	0	0	0	0	0	0
9	---	---	---	0	0	0	0	0	0	0	0	0
10	---	---	---	0	0	0.05	0	0	0	0	0	0.27
11	---	---	---	0	0	0	0	0	0	0.25	0	0
12	---	---	---	0	0.16	0.03	0	0	0	0.13	0	0
13	---	---	---	0	0	0	0	0	0	0.01	0	0
14	---	---	0.03	0	0	0	0	0	0	0	0	0
15	---	---	0	0	0	0.01	0	0	0	0	0	0
16	---	---	0	0	0	0	0	0.01	0	0	0	0
17	---	---	0	0	0	0	0	0	0	0	0	0
18	---	---	0	0	0	0	0	0	0.02	0.01	0	0
19	---	---	0	0	0	0	0	0	0	0.18	0	0
20	---	---	0	0	0	0.01	0	0	0	0	0	0
21	---	---	0	0	0	0	0	0	0	0	0	0
22	---	---	0	0	0	0	0.08	0	0	0	0	0
23	---	---	0	0.12	0	0.01	0.01	0	0	0	0	0
24	---	---	0	0	0	0	0	0	0	0	0	0
25	---	---	0	0	0	0	0	0	0	0	0	0
26	---	---	0	0	0	0	0	0	0	0.19	0	0
27	---	---	0.14	0.01	0	0	0	0	0	0	0	0
28	---	---	0.24	0.22	0	0	0	0	0	0	0	0
29	---	---	0.03	0.26		0	0	0	0	0	0	0
30	---	---	0	0.01		0	0	0	0	0	0	0
31	---		0	0		0		0		0.06	0	
Mean	---	---	0.02	0.02	0.01	0.00	0.00	0.00	0.00	0.03	0.00	0.01
Max	---	---	0.24	0.26	0.16	0.05	0.08	0.01	0.02	0.25	0.00	0.27
Min	---	---	0.00	0.00	0.00	0.00	0.00	0.00	0.00	0.00	0.00	0.00
Total	---	---	0.44	0.62	0.16	0.11	0.09	0.01	0.02	0.83	0.00	0.27

Data Source: IWVGA, Stetson Engineers Inc. Data Management System; via NOAA DCS, DCP - BE100E74

Bold-Italicized data values represent values based on incomplete data sets.

Daily Precipitation Data Chimney Peak Fire Station, Water Year 2022

Water year 2022
 Station Name Chimney Peak Fire Station
 Operating Agency IWVGA Agent - Stetson Engineers Inc.
 Latitude 35°52'08.5" N
 Longitude 118°00'42.6" W

DAY	Daily Precipitation (inches)											
	2021			2022								
	OCT	NOV	DEC	JAN	FEB	MAR	APR	MAY	JUN	JUL	AUG	SEP
1	0	0	0	0.03	0	0	0	0	0	0	0	0
2	0	0	0	0	0	0	0	0	0	0	0	0
3	0	0	0	0	0	0	0	0	0	0	0	0.05
4	0	0	0	0	0	0	0	0	0	0	0.03	0
5	0	0	0	0	0	0	0	0	0	0	0.38	0
6	0	0	0	0	0	0	0	0	0	0	0	0
7	0	0	0	0	0	0	0	0	0	0	0	0
8	0	0	0	0	0	0	0	0	0	0	0	0
9	0	0	0.01	0	0	0	0	0	0	0	0	0
10	0	0	0	0	0	0	0	0	0	0	0	0.51
11	0	0	0	0	0	0	0	0	0	0	0	0.08
12	0	0	0	0	0	0	0	0	0	0	0	0.55
13	0	0	0	0	0	0	0	0	0	0	0	0
14	0	0	0	0	0	0	0	0	0	0	0	0
15	0	0	0.31	0	0.01	0	0	0	0	0	0	0
16	0	0	0.52	0	0	0	0	0	0	0	0	0
17	0	0	0.03	0	0	0	0	0	0	0.01	0	0
18	0	0	0	0	0	0	0	0	0	0	0	0
19	0	0	0	0	0	0	0	0	0	0	0	0
20	0	0	0	0	0	0	0	0	0	0	0	0
21	0	0	0	0	0	0	0	0	0	0	0	0
22	0	0	0.15	0	0	0	0	0	0.42	0	0	0
23	0	0	2.11	0	0	0	0	0	0	0	0	0
24	0	0	0.04	0	0.12	0	0	0	0	0	0	0
25	0.35	0	0	0	0	0	0	0	0	0	0	0
26	0	0	0.06	0	0	0	0	0	0	0	0	0
27	0	0	0.01	0	0	0	0	0	0	0	0	0
28	0	0	0	0	0	0.09	0	0	0	0	0	0
29	0	0	0.06	0	0	0.01	0	0	0	0.08	0	0
30	0	0	0.58	0	0	0	0	0	0	0.27	0	0
31	0	0	0.07	0	0	0	0	0	0	1.09	0	0
Mean	0.01	0.00	0.13	0.00	0.00	0.00	0.00	0.00	0.01	0.05	0.01	0.04
Max	0.35	0.00	2.11	0.03	0.12	0.09	0.00	0.00	0.42	1.09	0.38	0.55
Min	0.00	0.00	0.00	0.00	0.00	0.00	0.00	0.00	0.00	0.00	0.00	0.00
Total	0.35	0.00	3.95	0.03	0.13	0.10	0.00	0.00	0.42	1.45	0.41	1.19

Data Source: IWVGA, Stetson Engineers Inc. Data Management System; via NOAA DCS, DCP - BE100E74

Bold-Italicized data values represent values based on incomplete data sets.

Daily Precipitation Data
Chimney Peak Fire Station, Water Year 2023

Water year 2023
 Station Name Chimney Peak Fire Station
 Operating Agency IWVGA Agent - Stetson Engineers Inc.
 Latitude 35°52'08.5" N
 Longitude 118°00'42.6" W

DAY	Daily Precipitation (inches)											
	2022 OCT	NOV	DEC	2023 JAN	FEB	MAR	APR	MAY	JUN	JUL	AUG	SEP
1	0	0	0.1	0.16	0	0.17	0	0	0	0	0	0.04
2	0	0	0.01	0.01	0	0	0	0	0	0	0	0.07
3	0	0	0.14	0.06	0	0	0	0	0	0	0	0
4	0	0	0.11	0.06	0	0	0	0.01	0	0	0	0
5	0	0	0	0.59	0.11	0	0	0	0	0	0	0
6	0	0	0	0.17	0	0	0	0	0	0	0	0
7	0	0.09	0	0	0	0	0	0	0.03	0	0	0
8	0	0.32	0.01	0.02	0	0	0	0	0	0	0	0
9	0	0.25	0	2.9	0	0.43	0	0	0	0	0	0
10	0	0	0	0.43	0	1.72	0	0	0	0	0	0
11	0	0	0.51	0.39	0	0.27	0	0	0.38	0	0	0
12	0	0	0.17	0.02	0	0.01	0	0	0.01	0	0.04	0
13	0	0	0.1	0	0	0	0	0	0	0	0.03	0
14	0	0	0	0.08	0	1.17	0	0	0.02	0	0	0
15	0	0	0	0.15	0	0.42	0	0	0	0	0.02	0
16	0	0	0	0.12	0	0	0	0	0	0	0.13	0
17	0	0	0	0.29	0	0	0	0	0	0	0	0
18	0	0	0	0.15	0	0	0	0	0	0	0	0
19	0	0	0	0	0	0.51	0	0	0	0	0.17	0
20	0	0	0	0	0	0	0	0	0	0	6.18	0
21	0	0	0	0	0	0.39	0	0	0	0	0.01	0
22	0	0	0	0	0	0.26	0	0.04	0	0	0	0
23	0	0	0	0	0.02	0	0	0	0	0	0	0
24	0	0	0	0	0	0	0	0	0	0	0	0
25	0	0	0	0	0.32	0.01	0	0	0	0	0	0
26	0	0	0	0	0.18	0	0	0	0	0	0	0
27	0	0	0.17	0	0.12	0	0	0	0	0	0	0
28	0	0	0	0	0.07	0	0	0	0	0	0	0
29	0	0	0	0		0.17	0	0	0	0	0	0
30	0	0	0.01	0		0.18	0	0	0	0	0	0
31	0		0.84	0		0		0.05		0	0	
Mean	0.00	0.02	0.07	0.18	0.03	0.18	0.00	0.00	0.01	0.00	0.21	0.00
Max	0.00	0.32	0.84	2.90	0.32	1.72	0.00	0.05	0.38	0.00	6.18	0.07
Min	0.00	0.00	0.00	0.00	0.00	0.00	0.00	0.00	0.00	0.00	0.00	0.00
Total	0.00	0.66	2.17	5.60	0.82	5.71	0.00	0.10	0.44	0.00	6.58	0.11

Data Source: IWVGA, Stetson Engineers Inc. Data Management System; via NOAA DCS, DCP - BE100E74

Bold-Italicized data values represent values based on incomplete data sets.

CHIMNEY PEAK PRECIPITATION STATION OVERVIEW

Stetson Engineers (Stetson) as acting agent for IWVGA, established this weather station December 2020, with the purpose of collecting regional precipitation data in an area where precipitation data collection has been missing. On December 14th, 2020, Stetson completed the installation of the Chimney Peak Precipitation Station at the Chimney Peak Bureau of Land Management (BLM) Fire Station. The installation was approved and permitted by the BLM with Communications Lease Agreement CACA 058717 and Categorical Exclusion Documentation DOI-BLM-CA-C060-2020-0015-CX. The station was installed inside the Chimney Peak BLM Fire Station facility, in the proposed location, at coordinate position, 35.86902, -118.01185.

The installation is comprised of components to measure and record precipitation, air temperature, and relative humidity measurements, and transmit this data through the NOAA GOES Data Collection System (DCS). The monitoring and telemetry equipment consist of the following listed component parts:

FTS Equipment List:

FTS Serial Number	Manufacture Serial Number	Model Number	Description
NA	NA	GPS-ANTENNA-WP	GPS Antenna
080028	52015405	1032-018	GOES Antenna EON2 Kit2, 401MHz, 6.0dBic
NA	NA	NA	EON2 Amiable Mount
NA	NA	20180	SMA Male to N Female Adapter
NA	NA	20514	Cable, N-Type Bulkhead to SMA M, 10"
118428	NA	LT1-GOES	LT1 Logger/Transceiver 1 GOES
119783	870470.008	21032	Lambrecht Temperature / Humidity Sensor
118802	NA	RG-T-FL	Rain Gage, Pedestal mount, 20 ft armored cable
118884	TS200528030	WS20G6M	20 Watt Solar Panel; SPS-20W-ASC
118884	NA	NA	ASC Battery Charge Regulator, Specialty Concepts, Inc.
NA	NA	12841-3	Charge Regulator to Battery Cable Assembly; MTL 2020-05-06
12220	NA	IT45-12-H	Battery – 12 Volt / 45 Ah
NA	NA	CBL-UC-JB-PWR	Battery to Terminal Cable Assembly; MTL 2020-06-15
1197784	NA	SDI-THPS-LB	Temperature/Humidity Sensor Radiation Shield
NA	NA	WP-ENCL-MINI	Weatherproof Equipment Enclosure, Mini Size
20385	CM106B	Tripod	7-10 ft Tripod with Grounding Kit

Photograph of Installation:



FIGURE 2. CHIMNEY PEAK WEATHER STATION FACING SOUTH-WEST



FIGURE 3. CHIMNEY PEAK WEATHER STATION, FACING SOUTH-WEST

Measurement & Telemetry Programming:

The datalogger / GOES transmitter (LT1) are programmed with the following NOAA DCS settings for data transmission through the NOAA GOES DCS.

Data Collection Platform:	BE100E74
Measurement Interval:	15 minutes
Transmission interval:	One hour
Transmission Offset:	34 minutes, 10 seconds
Parameter Encoding:	SHEF
Measurement Parameters:	VB – Battery Voltage; Volts PC – Accumulated Precipitation; Inches TA – Instantaneous Air Temperature, Celsius RH – Instantaneous Relative Humidity; Percent DP – Instantaneous Dew Point; Celsius BP – Instantaneous Barometric Pressure; Hectopascal

Stetson has implemented a data retrieval program to collect all environmental monitoring data for the Indian Wells Valley regions, transmitted through NOAA GOES DCS, including this Chimney Peak Precipitation Station. This data is collected and hosted on Indian Wells Valley Groundwater Sustainability Plan website, IWVGSP.com.



DRAFT MEMORANDUM

785 Grand Avenue, Suite 202 • Carlsbad, California • 94901
TEL: (760) 730-0701 FAX: (415) 457-1638 e-mail: stever@stetsonengineers.com

TO: File DATE: November 22, 2023
FROM: Stetson Engineers Inc. JOB NO: 2652
RE: Walker Pass East Weather Station – Annual Report of Precipitation, Water Year 2023

This memorandum serves as an annual summary of station operation and reporting of approved data records associated with the Walker Pass East Weather Station. IWVGA operation of this station is done under legal agreement with the Bureau of Land Management to occupy and operate the precipitation and telemetry equipment installed on the defunct Walker Pass East BLM RAWS weather station structure.

SUMMARY OF STATION OPERATIONS AND DATA – WY 2023

During WY 2023, in November 2022, this station was inadvertently demobilized by the Bureau of Land Management Southwest RAWS Field Group located in Phoenix Arizona. Subsequently the station equipment was stolen from the Arizona BLM equipment yard. As a result of this data for WY 2023 ends on November 9th, 2022. This loss of equipment and station operation was reported to the IWVGA Board once observed. This station has not been restored.

The following tables summarize the daily recorded precipitation totals, August 2020 through November 2022, by Water Year.

Daily Precipitation Data Walker Pass East, Water Year 2020

Water year 2020
 Station Name Walker Pass East
 Operating Agency IWVGA Agent - Stetson Engineers Inc.
 Latitude 35°39'45.4" N
 Longitude 118°01'31.7" W

Daily Precipitation (inches)												
DAY	2019			2020								
	OCT	NOV	DEC	JAN	FEB	MAR	APR	MAY	JUN	JUL	AUG	SEP
1	---	---	---	---	---	---	---	---	---	---	---	0
2	---	---	---	---	---	---	---	---	---	---	---	0
3	---	---	---	---	---	---	---	---	---	---	---	0
4	---	---	---	---	---	---	---	---	---	---	---	0
5	---	---	---	---	---	---	---	---	---	---	---	0
6	---	---	---	---	---	---	---	---	---	---	---	0
7	---	---	---	---	---	---	---	---	---	---	---	0
8	---	---	---	---	---	---	---	---	---	---	---	0
9	---	---	---	---	---	---	---	---	---	---	---	0
10	---	---	---	---	---	---	---	---	---	---	---	0
11	---	---	---	---	---	---	---	---	---	---	---	0
12	---	---	---	---	---	---	---	---	---	---	---	0
13	---	---	---	---	---	---	---	---	---	---	---	0
14	---	---	---	---	---	---	---	---	---	---	---	0
15	---	---	---	---	---	---	---	---	---	---	---	0
16	---	---	---	---	---	---	---	---	---	---	---	0
17	---	---	---	---	---	---	---	---	---	---	---	0
18	---	---	---	---	---	---	---	---	---	---	---	0
19	---	---	---	---	---	---	---	---	---	---	---	0
20	---	---	---	---	---	---	---	---	---	---	---	0
21	---	---	---	---	---	---	---	---	---	---	---	0
22	---	---	---	---	---	---	---	---	---	---	---	0
23	---	---	---	---	---	---	---	---	---	---	---	0
24	---	---	---	---	---	---	---	---	---	---	---	0
25	---	---	---	---	---	---	---	---	---	---	---	0
26	---	---	---	---	---	---	---	---	---	---	0	0
27	---	---	---	---	---	---	---	---	---	---	0	0
28	---	---	---	---	---	---	---	---	---	---	0	0
29	---	---	---	---	---	---	---	---	---	---	0	0
30	---	---	---	---	---	---	---	---	---	---	0	0
31	---	---	---	---	---	---	---	---	---	---	0	
Mean	---	---	---	---	---	---	---	---	---	---	---	0.00
Max	---	---	---	---	---	---	---	---	---	---	---	0.00
Min	---	---	---	---	---	---	---	---	---	---	---	0.00
Total	---	---	---	---	---	---	---	---	---	---	---	0.00

Data Source: IWVGA, Stetson Engineers Inc. Data Management System; via In-Situ HydroVu data platform

Daily Precipitation Data Walker Pass East, Water Year 2021

Water year 2021
 Station Name Walker Pass East
 Operating Agency IWVGA Agent - Stetson Engineers Inc.
 Latitude 35°39'45.4" N
 Longitude 118°01'31.7" W

Daily Precipitation (inches)												
DAY	2020			2021								
	OCT	NOV	DEC	JAN	FEB	MAR	APR	MAY	JUN	JUL	AUG	SEP
1	0	0	0	0	0	0	0	0	0	0	0	0
2	0	0	0	0	0	0	0	0	0	0	0	0
3	0	0	0	0	0	0	0	0	0	0	0	0
4	0	0	0	0	0	0	0	0	0	0	0	0
5	0	0	0	0	0	0	0	0	0	0	0	0
6	0	0	0	0	0	0	0	0	0	0	0	0
7	0	0	0.12	0	0	0	0	0	0	0	0	0
8	0	0	0.06	0	0	0	0	0	0	0	0	0
9	0	0	0	0	0	0	0.02	0	0	0	0	0
10	0	0	0	0	0	0	0.04	0	0	0	0	0
11	0	0	0	0	0	0	0.03	0	0	0	0	0
12	0	0	0	0	0	0	0.01	0	0	0	0	0
13	0	0	0	0	0	0	0	0	0	0	0	0
14	0	0	0	0	0	0.16	0	0	0	0	0	0
15	0	0	0	0	0	0	0	0	0	0	0	0
16	0	0	0	0.06	0	0	0	0	0	0	0	0
17	0	0	0	0	0	0	0	0	0	0	0.06	0
18	0	0	0	0	0.01	0	0	0	0	0	0	0
19	0	0	0	0	0	0	0.04	0	0	0	0	0
20	0	0	0	0	0	0	0	0	0	0	0	0
21	0	0	0	0	0	0	0	0	0	0	0	0
22	0	0	0	0	0.12	0	0	0	0	0	0	0
23	0	0	0	0	0.04	0	0	0	0	0	0	0
24	0	0	0	0	0	0	0	0	0	0	0	0
25	0	0	0	0	0	0	0	0	0	0	0.02	0
26	0	0	0	0.16	0.05	0	0	0	0	0	0	0
27	0	0	0	0.16	0.02	0	0	0	0	0	0	0
28	0	0	0	0	0.35	0	0	0	0	0	0	0
29	0	0	0	0	0	0	0	0	0	0	0.06	0
30	0	0	0	0	0	0	0	0	0	0	0.35	0
31	0	0	0	0	0	0	0	0	0	0	0	0
Mean	0.00	0.00	0.01	0.01	0.02	0.01	0.00	0.00	0.00	0.00	0.02	0.00
Max	0.00	0.00	0.12	0.16	0.35	0.16	0.04	0.00	0.00	0.00	0.35	0.00
Min	0.00	0.00	0.00	0.00	0.00	0.00	0.00	0.00	0.00	0.00	0.00	0.00
Total	0.00	0.00	0.18	0.38	0.59	0.16	0.14	0.00	0.00	0.00	0.49	0.00

Data Source: IWVGA, Stetson Engineers Inc. Data Management System; via In-Situ HydroVu data platform

Daily Precipitation Data Walker Pass East, Water Year 2022

Water year 2022
 Station Name Walker Pass East
 Operating Agency IWVGA Agent - Stetson Engineers Inc.
 Latitude 35°39'45.4" N
 Longitude 118°01'31.7" W

Daily Precipitation (inches)												
DAY	2021			2022								
	OCT	NOV	DEC	JAN	FEB	MAR	APR	MAY	JUN	JUL	AUG	SEP
1	0	0	0	0.01	0	0	0	0	0	0	0.21	0
2	0	0	0	0	0	0	0	0	0	0	1.11	0
3	0	0	0	0	0	0	0	0	0	0	0	0
4	0	0	0	0	0	0.01	0	0	0	0	0	0
5	0	0	0	0	0	0	0	0	0	0	0.7	0
6	0	0	0	0	0	0	0	0	0	0	0	0
7	0	0.02	0	0	0	0	0	0	0	0	0	0
8	0	0	0	0	0	0	0	0	0	0	0	0
9	0	0	0	0	0	0	0	0	0	0	0	0
10	0	0	0.06	0	0	0	0	0	0	0	0	0
11	0	0	0.01	0	0	0	0	0	0	0	0	0.01
12	0	0	0	0	0	0	0	0	0	0	0	0.01
13	0	0	0	0	0	0	0	0	0	0	0	0
14	0	0	0.02	0	0	0	0	0	0	0	0	0
15	0	0	0.4	0	0	0	0	0	0	0	0	0
16	0	0	0.03	0	0	0	0	0	0	0	0	0
17	0	0	0	0	0	0	0	0	0	0	0	0
18	0	0	0	0	0	0	0	0	0	0	0	0
19	0	0	0	0	0	0	0	0	0	0	0	0
20	0	0	0	0	0	0	0	0	0	0	0	0
21	0	0	0	0	0	0	0	0	0	0	0	0
22	0	0	0.06	0	0.01	0	0.08	0	0.68	0	0	0
23	0	0	1.63	0	0	0	0	0	0.08	0	0	0
24	0	0	0.38	0	0	0	0	0	0	0	0	0
25	0.35	0	0	0	0	0	0	0	0	0	0	0
26	0	0	0	0	0	0	0	0	0	0	0	0
27	0	0	0.06	0	0	0	0	0	0	0	0	0
28	0	0	0	0	0	0.15	0	0	0	0	0	0
29	0	0	0.1	0	0	0	0	0	0	0	0	0
30	0	0	0.55	0	0	0	0	0	0	0.38	0	0
31	0	0	0	0	0	0	0	0	0	1.08	0	0
Mean	0.01	0.00	0.11	0.00	0.00	0.01	0.00	0.00	0.03	0.05	0.07	0.00
Max	0.35	0.02	1.63	0.01	0.01	0.15	0.08	0.00	0.68	1.08	1.11	0.01
Min	0.00	0.00	0.00	0.00	0.00	0.00	0.00	0.00	0.00	0.00	0.00	0.00
Total	0.35	0.02	3.30	0.01	0.01	0.16	0.08	0.00	0.76	1.46	2.02	0.02

Data Source: IWVGA, Stetson Engineers Inc. Data Management System; via In-Situ HydroVu data platform

Daily Precipitation Data Walker Pass East, Water Year 2023

Water year 2023
 Station Name Walker Pass East
 Operating Agency IWVGA Agent - Stetson Engineers Inc.
 Latitude 35°39'45.4" N
 Longitude 118°01'31.7" W

Daily Precipitation (inches)												
DAY	2022			2023								
	OCT	NOV	DEC	JAN	FEB	MAR	APR	MAY	JUN	JUL	AUG	SEP
1	0	0.024	---	---	---	---	---	---	---	---	---	---
2	0	0.157	---	---	---	---	---	---	---	---	---	---
3	0	0	---	---	---	---	---	---	---	---	---	---
4	0	0	---	---	---	---	---	---	---	---	---	---
5	0	0	---	---	---	---	---	---	---	---	---	---
6	0	0	---	---	---	---	---	---	---	---	---	---
7	0	0.134	---	---	---	---	---	---	---	---	---	---
8	0	0	---	---	---	---	---	---	---	---	---	---
9	0	0.094	---	---	---	---	---	---	---	---	---	---
10	0	---	---	---	---	---	---	---	---	---	---	---
11	0	---	---	---	---	---	---	---	---	---	---	---
12	0	---	---	---	---	---	---	---	---	---	---	---
13	0	---	---	---	---	---	---	---	---	---	---	---
14	0	---	---	---	---	---	---	---	---	---	---	---
15	0	---	---	---	---	---	---	---	---	---	---	---
16	0	---	---	---	---	---	---	---	---	---	---	---
17	0	---	---	---	---	---	---	---	---	---	---	---
18	0	---	---	---	---	---	---	---	---	---	---	---
19	0	---	---	---	---	---	---	---	---	---	---	---
20	0	---	---	---	---	---	---	---	---	---	---	---
21	0	---	---	---	---	---	---	---	---	---	---	---
22	0	---	---	---	---	---	---	---	---	---	---	---
23	0	---	---	---	---	---	---	---	---	---	---	---
24	0	---	---	---	---	---	---	---	---	---	---	---
25	0	---	---	---	---	---	---	---	---	---	---	---
26	0	---	---	---	---	---	---	---	---	---	---	---
27	0	---	---	---	---	---	---	---	---	---	---	---
28	0	---	---	---	---	---	---	---	---	---	---	---
29	0	---	---	---	---	---	---	---	---	---	---	---
30	0	---	---	---	---	---	---	---	---	---	---	---
31	0	---	---	---	---	---	---	---	---	---	---	---
Mean	0.00	---	---	---	---	---	---	---	---	---	---	---
Max	0.00	---	---	---	---	---	---	---	---	---	---	---
Min	0.00	---	---	---	---	---	---	---	---	---	---	---
Total	0.00	0.41	---	---	---	---	---	---	---	---	---	---

Data Source: IWVGA, Stetson Engineers Inc. Data Management System; via In-Situ HydroVu data platform

WALKER PASS EAST PRECIPITATION STATION OVERVIEW

Stetson Engineers (Stetson) as acting agent for IWVGA, re-established precipitation monitoring at the defunct BLM Walker Pass East RAWS station. The existing RAWS weather station had become obsolete and is no longer operable when the NOAA DCP platform expired. The installation was approved and permitted by the BLM with Lease Agreement CACA 058727 and Categorical Exclusion Documentation DOI-BLM-CA-D050-2020-0008-CX. Stetson installed a new tipping bucket rain gage and data telemetry system retrofitted to the existing in place RAWS tripod structure, at coordinate position, 35.66261, -118.02548. The monitoring and telemetry equipment consist of the following listed component parts:

Equipment List:

Part Number	Description
HSA: TB4/0.01/T	Tipping bucket rain gauge, 0.2 mm resolution, dual reed switch outputs, measurement range 0-700mm/hr
In Situ: ISR-0000000-VL	VuLink Cellular Telemetry, 4G LTE, Antenna, GPS, 1.5-3.6V Li-MnO ₂ Battery, built in barometric sensor; HTTPS, FTP, SFTP, SMS, CSV file format

Photograph of Installation:



FIGURE 1. TIPPING BUCKET RAIN GAUGE INSTALLATION AT WALKER PASS EAST RAWS

Measurement & Telemetry Programming:

The datalogger and telemetry device is programmed to record observed rainfall in increments of 0.2 millimeters, with counting interval of 15 minutes. Using the software provided by In-Situ, the telemetry device was programmed to retrieve recorded water level readings from the Level TROLL 400 sensor every 15 minutes. The 15-minute time interval is based on the USGS stream gage standard. Additionally, the telemetry device was programmed to upload the 15-minute readings to In-Situ's FTP server every 24 hours, or 96 readings. The data is then collected from the In-Situ server and hosted on Indian Wells Valley Groundwater Sustainability Plan website, IWVGSP.com.



DRAFT MEMORANDUM

785 Grand Avenue, Suite 202 • Carlsbad, California • 94901
TEL: (760) 730-0701 FAX: (415) 457-1638 e-mail: stever@stetsonengineers.com

TO: File DATE: December 12, 2023
FROM: Stetson Engineers Inc. JOB NO: 2652
RE: Grapevine Canyon Stream Gaging Station – Annual Report of Stream Flows, Water Year 2023

This memorandum serves as an annual summary of station operation and reporting of approved data records associated with this monitoring station for Water Year (WY) 2023, October 2022 through September 2023. Due to issues with flooding, calculation of rated flows was only possible for a portion of the year. However due to the significance and magnitude of the runoff this year, estimates of flow have been made based on the correlation with the Sand Canyon Gage. With these estimates, the estimated total flow for WY2023 was 1,625 acre-feet. Figure 1 shows the annual streamflow measured at Grapevine Canyon over the period of record of operation.

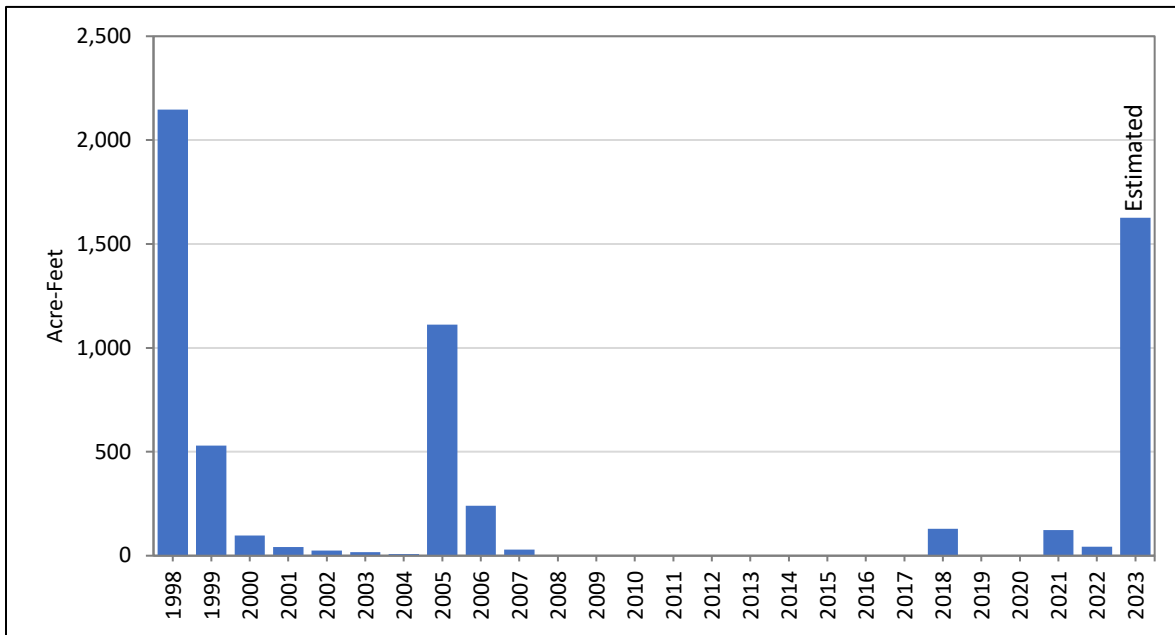

FIGURE 1. GRAPEVINE CANYON ANNUAL FLOW – PERIOD OF RECORD

SUMMARY OF GAGE OPERATIONS AND DATA – WY 2023

During WY 2023, three storm events, in March and August, resulted in significant flows in Grapevine Canyon exceeding the rating of the stream gage and overtopping the channel road crossing on which the station is located. These events resulted in damage to the property of the landowner on which the gage is located. During the flow events the gage weir plates were removed by the property owner to prevent obstruction of culvert structures and allow for maximum flow through the culverts. Stetson, in agreement with the property owner, decided to not pursue maintaining the weir plates in the channel out of an abundance of caution of future flood events causing property damage. At this time the creek channel at the gaging site has no gage equipment in place which would lead to channel obstruction. Monitoring of the stream gage height has continued. Figure 2 is a photograph of the gage location taken by the landowner during the event on March 15th.



FIGURE 2. GRAPEVINE CANYON GAGE STATION – MARCH 15, 2023, FLOW EVENT

The result of these weir operations, as well as the exceedance of the gage rating, is that calculating rated flow for this gage is not possible for WY 2023. This will remain the case until a new rating method is established for this gage location. After initial assessment of the gage location without the weir plates, suggest that developing a rating for this location with open channel flows will be challenging. 1) At the time of inspection, September 2023, significant sediment load was present actively traveling through the culvert creating a dynamic partial obstruction to the channel. 2) The intake pipe of for the stilling well in the channel is located at an elevation partially above the invert elevation of the culverts. During low flows there is potential that water stage height will not be translated from the channel to the stilling well.

In WY 2023 total annual streamflow could not be fully calculated due to the limitations on operations stated above. However, because of the significance of the events of the year, estimated flows have been calculated based on a flow correlation between Grapevine and Sad Canyon gage stations. Figure 3 shows the total monthly flows for WY 2023 with estimated values indicated.

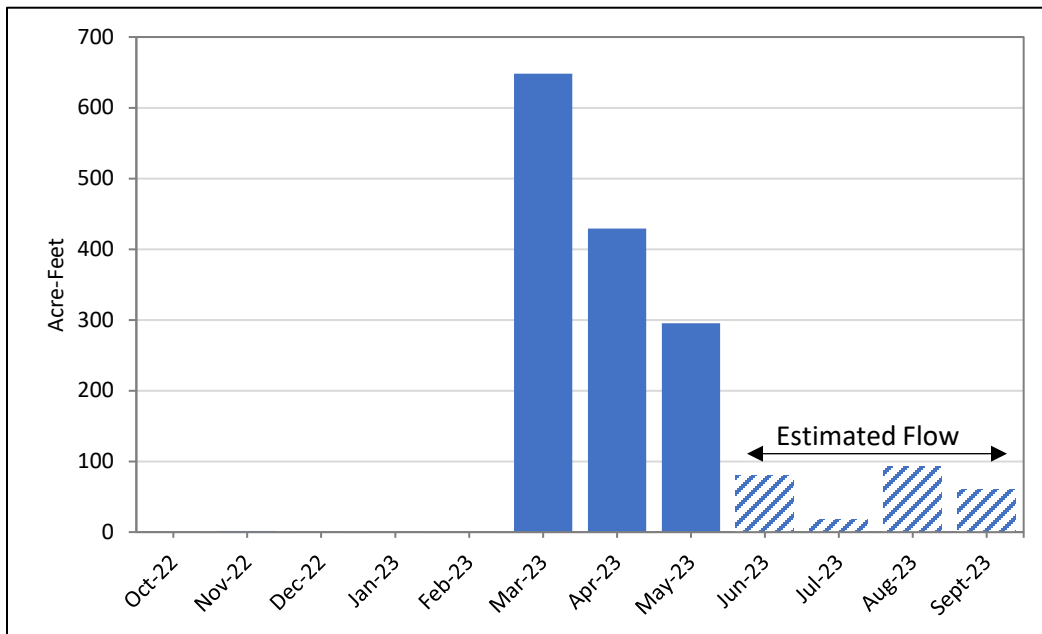

FIGURE 3. GRAPEVINE CANYON MONTHLY FLOW – WATER YEAR 2023

The following tables are provided to serve as reporting of approved daily values of data collected at the Grapevine Canyon gaging station. The tables reflect daily average stream flow rate in cubic feet per second, and total daily flows in acre-feet, by water year. Flows estimated based on Sand Canyon data are not included.

Daily Streamflow Data, Flow Rate Grapevine Canyon, Water Year 2023

Water year 2023
 Station Name Grapevine Canyon
 Operating Agency IWVGA Agent - Stetson Engineers Inc.
 Latitude 35°43'59.4"N
 Longitude 117°55'00.4"N

Daily streamflow (cfs)												
DAY	2022			2023								
	OCT	NOV	DEC	JAN	FEB	MAR	APR	MAY	JUN	JUL	AUG	SEP
1	0.02	0.01	0.03	0.01	0.00	0.02	5.72	8.05	---	---	---	---
2	0.02	0.02	0.03	0.01	0.00	0.01	5.65	8.05	---	---	---	---
3	0.01	0.02	0.02	0.01	0.00	0.01	5.69	7.68	---	---	---	---
4	0.02	0.03	0.02	0.01	0.00	0.01	5.47	7.24	---	---	---	---
5	0.01	0.03	0.03	0.01	0.00	0.01	5.29	6.98	---	---	---	---
6	0.01	0.02	0.02	0.01	0.00	0.01	5.19	6.70	---	---	---	---
7	0.01	0.02	0.01	0.01	0.00	0.01	4.97	6.32	---	---	---	---
8	0.01	0.03	0.01	0.01	0.00	0.01	4.95	6.01	---	---	---	---
9	0.01	0.02	0.01	0.02	0.00	0.01	5.15	5.82	---	---	---	---
10	0.01	0.02	0.01	0.02	0.00	0.05	5.47	5.57	---	---	---	---
11	0.01	0.02	0.02	0.01	0.00	<u>44.99</u>	6.06	5.38	---	---	---	---
12	0.01	0.02	0.02	0.01	0.00	<u>27.78</u>	8.06	5.10	---	---	---	---
13	0.01	0.02	0.02	0.01	0.00	9.42	9.13	4.89	---	---	---	---
14	0.01	0.02	0.02	0.01	0.00	<u>11.49</u>	7.81	4.77	---	---	---	---
15	0.01	0.02	0.02	0.02	0.00	<u>49.54</u>	7.10	4.61	---	---	---	---
16	0.02	0.02	0.02	0.01	0.00	<u>38.28</u>	7.11	4.52	---	---	---	---
17	0.01	0.02	0.02	0.01	0.00	<u>20.93</u>	7.93	4.38	---	---	---	---
18	0.01	0.03	0.02	0.01	0.00	15.18	8.53	4.26	---	---	---	---
19	0.01	0.03	0.02	0.01	0.00	14.58	8.17	4.07	---	---	---	---
20	0.01	0.03	0.01	0.01	0.00	11.07	7.92	3.87	---	---	---	---
21	0.01	0.03	0.01	0.01	0.00	10.78	8.24	3.87	---	---	---	---
22	0.01	0.03	0.01	0.01	0.00	9.66	8.32	3.78	---	---	---	---
23	0.01	0.03	0.01	0.01	0.00	8.73	8.48	3.77	---	---	---	---
24	0.02	0.04	0.01	0.01	0.02	8.02	9.50	3.65	---	---	---	---
25	0.01	0.04	0.01	0.01	0.03	7.55	9.48	3.64	---	---	---	---
26	0.01	0.04	0.01	0.01	0.02	7.09	8.95	3.53	---	---	---	---
27	0.01	0.04	0.01	0.01	0.02	6.61	8.22	3.40	---	---	---	---
28	0.02	0.03	0.01	0.01	0.02	6.44	7.96	<i>3.24</i>	---	---	---	---
29	0.01	0.03	0.01	0.01		6.44	8.01	---	---	---	---	---
30	0.01	0.03	0.01	0.00		6.16	7.87	---	---	---	---	---
31	0.01		0.01	0.00		5.84		---	---	---	---	---
Mean (cfs)	0.01	0.03	0.02	0.01	0.00	10.54	7.21	<i>5.11</i>	---	---	---	---
Max (cfs)	0.02	0.04	0.03	0.02	0.03	49.54	9.50	<i>8.05</i>	---	---	---	---
Min (cfs)	0.01	0.01	0.01	0.00	0.00	0.01	4.95	<i>3.24</i>	---	---	---	---
Total (ac-ft)	1	2	1	1	0	648	429	<i>284</i>	---	---	---	---

Data Source: IWVGA, Stetson Engineers Inc. Data Management System; via NOAA DCS, DCP - BE1000A6

Bold underlined - Values are estimates due to flow exceedance of the stream gage rating table

Italicized - Values are based on incomplete data records

Daily Streamflow Data, Total Flow Volume Grapevine Canyon, Water Year 2023

Water year 2023
 Station Name Grapevine Canyon
 Operating Agency IWVGA Agent - Stetson Engineers Inc.
 Latitude 35°43'59.4"N
 Longitude 117°55'00.4"N

Daily streamflow (AF)												
DAY	2022			2023								
	OCT	NOV	DEC	JAN	FEB	MAR	APR	MAY	JUN	JUL	AUG	SEP
1	0.03	0.03	0.06	0.02	0.01	0.03	11.35	15.97	---	---	---	---
2	0.03	0.04	0.05	0.02	0.01	0.02	11.21	15.97	---	---	---	---
3	0.02	0.05	0.05	0.02	0.01	0.01	11.28	15.24	---	---	---	---
4	0.03	0.05	0.04	0.02	0.00	0.02	10.86	14.36	---	---	---	---
5	0.03	0.06	0.05	0.02	0.00	0.02	10.49	13.84	---	---	---	---
6	0.02	0.04	0.04	0.02	0.00	0.02	10.30	13.29	---	---	---	---
7	0.02	0.04	0.02	0.02	0.00	0.02	9.85	12.53	---	---	---	---
8	0.03	0.06	0.02	0.02	0.00	0.02	9.82	11.93	---	---	---	---
9	0.03	0.04	0.02	0.03	0.00	0.02	10.22	11.54	---	---	---	---
10	0.02	0.04	0.02	0.03	0.00	0.09	10.85	11.04	---	---	---	---
11	0.02	0.04	0.04	0.02	0.00	<u>89.24</u>	12.02	10.67	---	---	---	---
12	0.02	0.04	0.03	0.01	0.00	<u>55.10</u>	15.98	10.11	---	---	---	---
13	0.02	0.04	0.03	0.01	0.00	18.69	18.10	9.70	---	---	---	---
14	0.02	0.04	0.03	0.02	0.00	<u>22.79</u>	15.49	9.46	---	---	---	---
15	0.03	0.04	0.03	0.03	0.00	<u>98.26</u>	14.08	9.15	---	---	---	---
16	0.04	0.05	0.03	0.03	0.00	<u>75.92</u>	14.11	8.97	---	---	---	---
17	0.03	0.05	0.03	0.01	0.00	<u>41.51</u>	15.74	8.69	---	---	---	---
18	0.02	0.05	0.03	0.01	0.00	30.10	16.93	8.45	---	---	---	---
19	0.02	0.05	0.03	0.01	0.00	28.92	16.20	8.06	---	---	---	---
20	0.02	0.05	0.03	0.01	0.00	21.95	15.71	7.68	---	---	---	---
21	0.02	0.05	0.03	0.01	0.00	21.38	16.34	7.68	---	---	---	---
22	0.02	0.06	0.03	0.01	0.00	19.16	16.50	7.49	---	---	---	---
23	0.03	0.07	0.03	0.01	0.00	17.32	16.82	7.47	---	---	---	---
24	0.03	0.07	0.03	0.01	0.04	15.90	18.83	7.24	---	---	---	---
25	0.03	0.07	0.03	0.01	0.07	14.98	18.80	7.21	---	---	---	---
26	0.02	0.07	0.03	0.01	0.03	14.06	17.75	7.00	---	---	---	---
27	0.02	0.07	0.02	0.01	0.04	13.11	16.30	6.75	---	---	---	---
28	0.03	0.06	0.02	0.01	0.04	12.78	15.80	<i>6.42</i>	---	---	---	---
29	0.02	0.06	0.02	0.01		12.76	15.90	---	---	---	---	---
30	0.02	0.06	0.02	0.01		12.21	15.60	---	---	---	---	---
31	0.02		0.03	0.01		11.59		---	---	---	---	---
Mean (ac-ft)	0.02	0.05	0.03	0.02	0.01	20.90	14.31	<i>10.14</i>	---	---	---	---
Max (ac-ft)	0.04	0.07	0.06	0.03	0.07	98.26	18.83	<i>15.97</i>	---	---	---	---
Min (ac-ft)	0.02	0.03	0.02	0.01	0.00	0.01	9.82	<i>6.42</i>	---	---	---	---
Total (ac-ft)	1	2	1	1	0	648	429	<i>284</i>	---	---	---	---

Data Source: IWVGA, Stetson Engineers Inc. Data Management System; via NOAA DCS, DCP - BE1000A6

Bold underlined - Values are estimates due to flow exceedance of the stream gage rating table

Italicized - Values are based on incomplete data records

GRAPEVINE CANYON STREAM GAGING STATION OVERVIEW

Stetson Engineers (Stetson) as acting agent for IWVGA, re-established monitoring activities at the Grapevine Canyon Stream Gaging Station, on August 26, 2020. Prior to this the Station had been in a defunct state following the cessation of Kern County Water Agency monitoring activities in 2019. Kern County Water Agency (KCWA) previously operated this gaging station with permission of the private property owner where the gage is located. Stetson established an operational agreement with the property owner on behalf of the IWVGA, in order to install and operate the stream gaging and telemetry equipment. To re-establish the monitoring station Stetson, rehabilitated the weir structure and installed new monitoring and satellite telemetry components inside the stilling well. This work planning and installation work is summarized as a Memorandum submitted to the State Department of Water Resources, dated August 28, 2020.

The gaging facility consists of a channel spanning split flow weir. The weir is composed of a V-notched weir and a sharp crested rectangular weir. There was no automatic datalogging or telemetry equipment previously installed at this site. Measurement of upstream pool height is accomplished utilizing an existing staff gage and through a stilling well with a mounted steel box for housing gaging instrumentation. The monitoring and telemetry equipment consist of the following listed component parts:

Equipment List:

Part Number	Description
Stevens Water Part No. 93876	SatComm GOES Transmitter
Stevens Water Part No. 51108	GPS Antenna
Stevens Water Part No. 70018	V2TH Satellite Antenna
Stevens Water Part No. 93750-100	DLight Datalogger
Stevens Water Part No. 70217-100	SOLO Solar Charge Regulator
Stevens Water Part No. 93720-135	SDX Pressure Sensor
Stevens Water Part No. 93030-001	Desiccant Cartridge
Third Party Vendor	25 Watt / 12 Volt Solar Panel
Third Party Vendor	12 Volt / 20 Amp-hour Rechargeable Battery

Photographs of Installation:



FIGURE 4. STILLING WELL AND ENCLOSURE WITH MOUNTED SOLAR PANEL AND SATELLITE ANTENNA



FIGURE 5. REHABILITATED SHARP CRESTED WEIR ON THE LEFT CULVERT OPENING.

Data Resolution & Telemetry Programming:

The Stevens datalogger is programmed to measure and record water level readings every 15 minutes. This 15-minute time interval is based on the USGS stream gage standard. From there the Stevens GOES transmitter is programmed with a NOAA assigned satellite transmission assignment (Data Collection Platform: BE1000A6) to transmit data on an hourly basis to the NOAA GOES Data Collection System (DCS). Utilizing DCS data collection scripts Stetson retrieves monitoring data from the DCS daily to integrate into the IWVGSP Data Management System.

Staff Gauge vs. Weir Stage:

During installation it was observed that the existing staff gauge is installed with 1.00 feet equaling the crest of the V-notch Weir. Staff gage readings reported here are reflective of this 1 foot difference, and calculations of weir discharge utilize stage values 1-foot less than the staff readings.

Calculation of Discharge:

Calculation of stream discharge utilizes corrected stage measurements, recorded with the stilling well monitoring equipment, and the following equations (Francis Equation) utilized by Kern County Water Agency. Adjustments have been made reflecting the stage height differences between activation of the two weirs, using elevation measurements obtained after the installation of the rehabilitated weir, Stetson established the stage-discharge relationship which can be seen in Figure 6.

Discharge Equation(s) for Grapevine Canyon Weir Structure

The discharge equation is the sum of the water passing through the v-notch and rectangular weirs as described by the following equations.

90° V-Notch Weir Component Discharge: $Q = 2.49 \times H^{2.48}$

Rectangular Weir Component Discharge: $Q = 3.33 \times (H - 0.35)^{3/2} \times (L - 0.02 \times H)$

Where:

Q = Discharge in cubic feet per second

L = Width of rectangular weir (24 inches)

H = water stage height weir crests (crest height difference of two weirs is 0.47 ft)

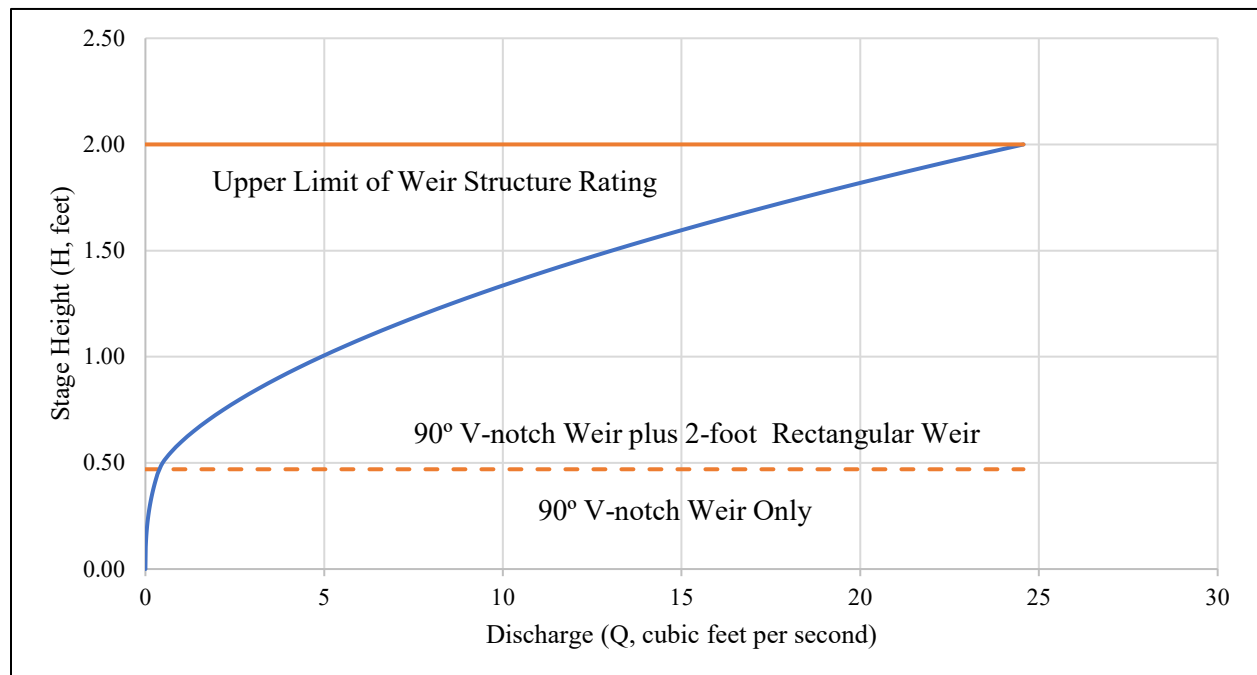

FIGURE 6. RATING CURVE FOR GRAPEVINE CANYON WEIR STRUCTURE



DRAFT MEMORANDUM

785 Grand Avenue, Suite 202 • Carlsbad, California • 94901
TEL: (760) 730-0701 FAX: (415) 457-1638 e-mail: stever@stetsonengineers.com

TO: File DATE: November 22, 2023
FROM: Stetson Engineers Inc. JOB NO: 2652
RE: Sand Canyon Stream Gaging Station – Annual Report of Stream Flows, Water Year 2023

This memorandum serves as an annual summary of station operation and reporting of approved data records associated with the Sand Canyon Stream Gage monitoring station for Water Year (WY) 2023, October 2022 through September 2023. Water measured during WY 2023 was the second highest recorded volume at this location, equaling 2,529 acre-feet. Figure 1 shows the annual streamflow measured at Sand Canyon over the period of record of operation for this location.

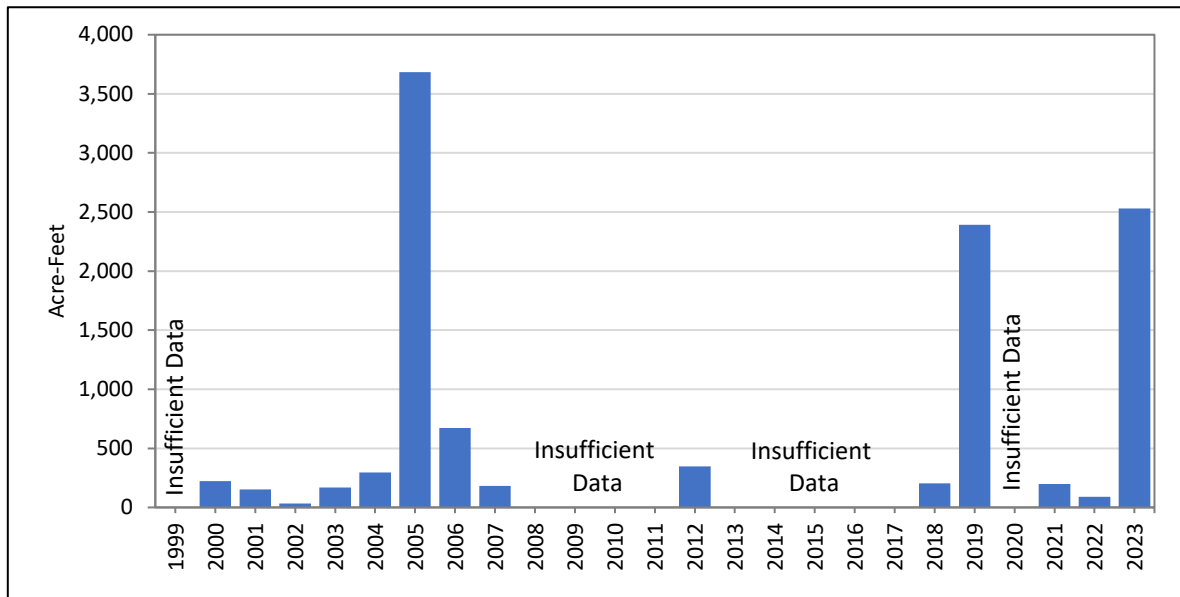

FIGURE 1. SAND CANYON ANNUAL FLOW – PERIOD OF RECORD

SUMMARY OF GAGE OPERATIONS AND DATA – WY 2023

During WY 2023, three site visits were made to conduct manual measurements and maintenance of the gage, October 2022, March 2023, and September 2023. During the October

2022 site visit the stream channel was dry and only maintenance to the monitoring telemetry equipment was conducted. The March 2023 site visit was conducted during low water conditions prior to the major storm runoff events of March. The September 2023 site visit was done at the end of the water year after all runoff events. Standard measurements and maintenance was conducted including the clearing of the weir of vegetation impacting weir operation.

During WY 2023 this gage experienced three storm-runoff events which resulted in stream stage heights exceeding the rated height of the weir. The dates of these occurrences were; March 10th – 12th, March 15th – 16th, and August 20th – 21st. For these periods discharge calculations were based on an extrapolation of the current rating. Measured flow for these dates are recognized as estimates. The following figure shows the total monthly flows for Water Year 2023.

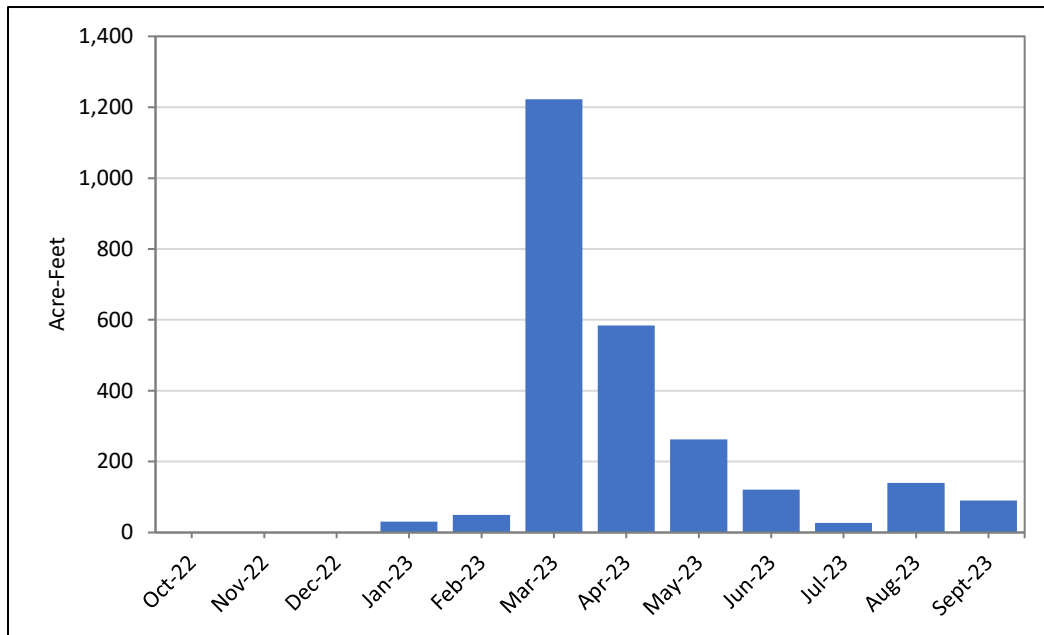

FIGURE 2. SAND CANYON MONTHLY FLOW – WATER YEAR 2023

Since its establishment in August 2020, the Sand Canyon stream gage has experienced seasonal flow, with the channel drying during the summer dry months. During WY2023 the channel remained wetted throughout these normally dry months, which permitted vegetation growth throughout the year, partially impairing the operation of the weir. Minor correction of the stage data was completed to address this influence of the vegetation on the data.

Daily Streamflow Data, Staff Gauge Reading Sand Canyon, Water Year 2023

Water year 2023
 Station Name Sand Canyon
 Operating Agency IWVGA Agent - Stetson Engineers Inc.
 Latitude 35°46'33.6"N
 Longitude 117°54'27.4"N

Average Daily Staff Gauge Reading (Feet)												
DAY	2022			2023								
	OCT	NOV	DEC	JAN	FEB	MAR	APR	MAY	JUN	JUL	AUG	SEP
1	0.00	0.00	0.00	0.01	0.19	0.65	1.04	0.93	0.58	0.29	0.10	0.37
2	0.00	0.00	0.00	0.00	0.19	0.56	1.04	0.92	0.56	0.27	0.09	0.41
3	0.00	0.00	0.00	0.00	0.20	0.57	1.03	0.90	0.54	0.25	0.09	0.41
4	0.00	0.00	0.00	0.00	0.21	0.59	1.00	0.90	0.53	0.26	0.09	0.40
5	0.00	0.00	0.00	0.01	0.23	0.59	0.99	0.88	0.53	0.26	0.08	0.39
6	0.00	0.00	0.00	0.00	0.21	0.58	0.98	0.87	0.55	0.26	0.08	0.38
7	0.00	0.00	0.00	0.00	0.21	0.57	0.98	0.85	0.61	0.26	0.09	0.37
8	0.00	0.00	0.00	0.00	0.21	0.58	0.97	0.85	0.58	0.25	0.08	0.36
9	0.00	0.00	0.00	0.02	0.21	0.57	0.97	0.84	0.54	0.25	0.10	0.34
10	0.00	0.00	0.00	0.39	0.22	1.50	0.98	0.83	0.54	0.24	0.10	0.37
11	0.00	0.00	0.00	0.34	0.23	2.02	1.05	0.82	0.58	0.23	0.10	0.42
12	0.00	0.00	0.00	0.02	0.23	1.70	1.15	0.80	0.57	0.21	0.10	0.44
13	0.00	0.00	0.00	0.01	0.23	1.47	1.17	0.79	0.53	0.20	0.11	0.44
14	0.00	0.00	0.00	0.00	0.23	1.53	1.12	0.78	0.52	0.19	0.11	0.43
15	0.00	0.00	0.00	0.58	0.21	2.16	1.08	0.76	0.51	0.17	0.10	0.43
16	0.00	0.00	0.00	0.43	0.20	1.75	1.06	0.75	0.49	0.16	0.10	0.42
17	0.00	0.00	0.00	0.35	0.20	1.56	1.05	0.73	0.47	0.16	0.10	0.42
18	0.00	0.00	0.00	0.26	0.20	1.44	1.05	0.71	0.45	0.15	0.09	0.42
19	0.00	0.00	0.00	0.24	0.21	1.41	1.03	0.69	0.47	0.14	0.16	0.41
20	0.00	0.00	0.00	0.21	0.21	1.32	1.00	0.68	0.46	0.14	0.71	0.43
21	0.00	0.00	0.00	0.19	0.24	1.34	0.99	0.69	0.45	0.13	1.44	0.42
22	0.00	0.00	0.00	0.20	0.23	1.31	0.98	0.69	0.44	0.13	0.90	0.42
23	0.00	0.00	0.00	0.18	0.21	1.23	0.98	0.67	0.43	0.13	0.81	0.43
24	0.00	0.00	0.00	0.17	0.27	1.19	0.98	0.66	0.43	0.13	0.71	0.41
25	0.00	0.00	0.00	0.17	0.78	1.16	0.98	0.65	0.42	0.11	0.62	0.42
26	0.00	0.00	0.00	0.17	0.52	1.13	0.97	0.65	0.41	0.12	0.55	0.39
27	0.00	0.00	0.00	0.19	0.52	1.10	0.96	0.63	0.40	0.10	0.49	0.40
28	0.00	0.00	0.00	0.19	0.61	1.09	0.94	0.62	0.38	0.09	0.45	0.40
29	0.00	0.00	0.00	0.21		1.11	0.93	0.62	0.35	0.09	0.42	0.41
30	0.00	0.00	0.00	0.20		1.09	0.93	0.63	0.33	0.08	0.40	0.43
31	0.00		0.00	0.19		1.05		0.61		0.09	0.39	
Mean (ft)	0.00	0.00	0.00	0.16	0.27	1.16	1.01	0.75	0.49	0.18	0.32	0.41

Data Source: IWVGA, Stetson Engineers Inc. Data Management System; via In-Situ HydroVu data platform

Daily Streamflow Data, Flow Rate Sand Canyon, Water Year 2023

Water year 2023
 Station Name Sand Canyon
 Operating Agency IWVGA Agent - Stetson Engineers Inc.
 Latitude 35°46'33.6"N
 Longitude 117°54'27.4"N

DAY	Daily streamflow (cfs)											
	2022 OCT	NOV	DEC	2023 JAN	FEB	MAR	APR	MAY	JUN	JUL	AUG	SEP
1	0.00	0.00	0.00	0.00	0.44	3.08	10.64	7.35	2.61	0.89	0.13	1.32
2	0.00	0.00	0.00	0.00	0.44	2.47	10.51	6.99	2.51	0.83	0.13	1.53
3	0.00	0.00	0.00	0.00	0.48	2.52	10.25	6.55	2.35	0.74	0.12	1.57
4	0.00	0.00	0.00	0.00	0.52	2.70	9.35	6.35	2.28	0.76	0.12	1.51
5	0.00	0.00	0.00	0.00	0.60	2.68	9.00	5.84	2.29	0.78	0.11	1.42
6	0.00	0.00	0.00	0.00	0.54	2.61	8.76	5.64	2.44	0.76	0.10	1.37
7	0.00	0.00	0.00	0.00	0.51	2.55	8.68	5.28	2.82	0.76	0.10	1.30
8	0.00	0.00	0.00	0.00	0.53	2.58	8.39	5.21	2.59	0.72	0.10	1.25
9	0.00	0.00	0.00	0.02	0.54	2.55	8.34	5.12	2.35	0.73	0.14	1.17
10	0.00	0.00	0.00	2.16	0.57	39.20	8.79	4.92	2.37	0.69	0.15	1.32
11	0.00	0.00	0.00	1.31	0.62	60.17	10.87	4.70	2.59	0.64	0.15	1.62
12	0.00	0.00	0.00	0.01	0.59	40.99	14.56	4.49	2.57	0.55	0.15	1.69
13	0.00	0.00	0.00	0.00	0.60	28.98	15.45	4.30	2.29	0.49	0.17	1.69
14	0.00	0.00	0.00	0.00	0.61	32.34	13.50	4.21	2.21	0.46	0.16	1.66
15	0.00	0.00	0.00	2.69	0.51	69.88	12.03	3.99	2.17	0.41	0.15	1.66
16	0.00	0.00	0.00	1.65	0.48	43.92	11.20	3.90	2.03	0.35	0.15	1.62
17	0.00	0.00	0.00	1.20	0.49	33.37	10.98	3.74	1.89	0.35	0.13	1.58
18	0.00	0.00	0.00	0.76	0.48	27.23	11.05	3.53	1.81	0.33	0.12	1.57
19	0.00	0.00	0.00	0.64	0.51	26.11	10.24	3.37	1.92	0.28	0.34	1.53
20	0.00	0.00	0.00	0.51	0.54	21.89	9.43	3.34	1.83	0.28	8.25	1.66
21	0.00	0.00	0.00	0.44	0.64	22.83	8.99	3.37	1.79	0.26	30.75	1.60
22	0.00	0.00	0.00	0.47	0.62	21.42	8.77	3.36	1.75	0.24	6.68	1.59
23	0.00	0.00	0.00	0.41	0.51	17.83	8.72	3.27	1.64	0.24	4.67	1.62
24	0.00	0.00	0.00	0.36	0.81	16.04	8.64	3.17	1.66	0.23	3.66	1.54
25	0.00	0.00	0.00	0.36	4.45	14.90	8.67	3.13	1.61	0.20	2.92	1.60
26	0.00	0.00	0.00	0.37	2.19	13.80	8.49	3.09	1.56	0.20	2.45	1.41
27	0.00	0.00	0.00	0.43	2.18	12.93	8.14	2.94	1.50	0.15	2.05	1.48
28	0.00	0.00	0.00	0.46	2.84	12.41	7.57	2.86	1.41	0.14	1.82	1.49
29	0.00	0.00	0.00	0.52		12.99	7.27	2.86	1.24	0.13	1.63	1.54
30	0.00	0.00	0.00	0.47		12.41	7.26	2.93	1.11	0.11	1.51	1.66
31	0.00		0.00	0.43		11.03		2.83		0.12	1.42	
Mean (cfs)	0.00	0.00	0.00	0.51	0.89	19.88	9.82	4.28	2.04	0.45	2.28	1.52
Max (cfs)	0.00	0.00	0.00	2.69	4.45	69.88	15.45	7.35	2.82	0.89	30.75	1.69
Min (cfs)	0.00	0.00	0.00	0.00	0.44	2.47	7.26	2.83	1.11	0.11	0.10	1.17
Total (ac-ft)	0	0	0	31	49	1,223	584	263	121	27	140	90

Data Source: IWVGA, Stetson Engineers Inc. Data Management System; via In-Situ HydroVu data platform
Bold underlined - Values are estimates due to flow exedance of the stream gage rating table

Daily Streamflow Data, Total Flow Volume Sand Canyon, Water Year 2023

Water year 2023
 Station Name Sand Canyon
 Operating Agency IWVGA Agent - Stetson Engineers Inc.
 Latitude 35°46'33.6"N
 Longitude 117°54'27.4"N

DAY	Daily streamflow (AF)											
	2022 OCT	NOV	DEC	2023 JAN	FEB	MAR	APR	MAY	JUN	JUL	AUG	SEP
1	0.00	0.00	0.00	0.00	0.87	6.11	21.11	14.59	5.19	1.77	0.26	2.62
2	0.00	0.00	0.00	0.00	0.87	4.90	20.85	13.86	4.98	1.64	0.25	3.04
3	0.00	0.00	0.00	0.00	0.95	5.00	20.33	13.00	4.67	1.46	0.24	3.11
4	0.00	0.00	0.00	0.00	1.03	5.36	18.55	12.59	4.52	1.51	0.25	2.99
5	0.00	0.00	0.00	0.00	1.18	5.31	17.85	11.59	4.54	1.55	0.23	2.81
6	0.00	0.00	0.00	0.00	1.06	5.18	17.38	11.18	4.84	1.50	0.20	2.72
7	0.00	0.00	0.00	0.00	1.02	5.05	17.21	10.47	5.58	1.51	0.21	2.58
8	0.00	0.00	0.00	0.00	1.05	5.13	16.64	10.33	5.13	1.43	0.19	2.47
9	0.00	0.00	0.00	0.03	1.07	5.05	16.54	10.15	4.67	1.44	0.27	2.31
10	0.00	0.00	0.00	4.29	1.13	77.75	17.44	9.76	4.71	1.38	0.30	2.62
11	0.00	0.00	0.00	2.61	1.24	119.35	21.57	9.32	5.14	1.27	0.30	3.21
12	0.00	0.00	0.00	0.02	1.17	81.30	28.88	8.90	5.09	1.10	0.29	3.35
13	0.00	0.00	0.00	0.00	1.19	57.48	30.64	8.54	4.55	0.97	0.34	3.35
14	0.00	0.00	0.00	0.00	1.21	64.14	26.78	8.35	4.38	0.91	0.32	3.29
15	0.00	0.00	0.00	5.33	1.02	138.60	23.86	7.92	4.30	0.81	0.29	3.30
16	0.00	0.00	0.00	3.27	0.95	87.12	22.21	7.73	4.03	0.70	0.29	3.21
17	0.00	0.00	0.00	2.38	0.97	66.18	21.78	7.42	3.76	0.70	0.27	3.13
18	0.00	0.00	0.00	1.50	0.95	54.01	21.91	7.00	3.58	0.65	0.25	3.11
19	0.00	0.00	0.00	1.26	1.02	51.78	20.30	6.69	3.81	0.56	0.68	3.04
20	0.00	0.00	0.00	1.01	1.06	43.42	18.70	6.62	3.63	0.55	16.37	3.29
21	0.00	0.00	0.00	0.87	1.26	45.28	17.83	6.69	3.55	0.52	60.98	3.18
22	0.00	0.00	0.00	0.94	1.23	42.49	17.40	6.66	3.47	0.48	13.24	3.15
23	0.00	0.00	0.00	0.81	1.01	35.37	17.30	6.49	3.26	0.48	9.26	3.22
24	0.00	0.00	0.00	0.72	1.61	31.82	17.15	6.28	3.30	0.46	7.27	3.05
25	0.00	0.00	0.00	0.72	8.82	29.56	17.20	6.21	3.19	0.39	5.79	3.18
26	0.00	0.00	0.00	0.74	4.34	27.37	16.84	6.13	3.10	0.41	4.86	2.79
27	0.00	0.00	0.00	0.85	4.33	25.64	16.15	5.84	2.98	0.31	4.06	2.93
28	0.00	0.00	0.00	0.91	5.63	24.61	15.02	5.67	2.79	0.28	3.61	2.97
29	0.00	0.00	0.00	1.02		25.76	14.42	5.67	2.46	0.25	3.23	3.06
30	0.00	0.00	0.00	0.93		24.62	14.40	5.81	2.20	0.22	2.99	3.29
31	0.00		0.00	0.85		21.89		5.61		0.25	2.82	
Mean (ac-ft)	0.00	0.00	0.00	1.00	1.76	39.44	19.47	8.49	4.05	0.89	4.51	3.01
Max (ac-ft)	0.00	0.00	0.00	5.33	8.82	138.60	30.64	14.59	5.58	1.77	60.98	3.35
Min (ac-ft)	0.00	0.00	0.00	0.00	0.87	4.90	14.40	5.61	2.20	0.22	0.19	2.31
Total (ac-ft)	0	0	0	31	49	1,223	584	263	121	27	140	90

Data Source: IWVGA, Stetson Engineers Inc. Data Management System; via In-Situ HydroVu data platform
Bold underlined - Values are estimates due to flow exedance of the stream gage rating table

The following attached tables are provided to serve as reporting of approved daily values of data collected at the Sand Canyon gaging station during WY 2023. The tables reflect; daily average staff gauge readings, daily average stream flow rate in cubic feet per second, and total daily flows in acre-feet; by water year.

SAND CANYON STREAM GAGING STATION OVERVIEW

IWVGA operation of this station is done under legal agreement with the Bureau of Land Management to occupy and operate the stream gage location. Stetson Engineers (Stetson) as acting agent for IWVGA, re-established monitoring activities at the Sand Canyon Stream Gaging Station, on August 25, 2020. Prior to this the Station was in a semi-defunct state following the cessation of Kern County Water Agency monitoring activities in 2019. As of the time of installation the station and associated stage measuring equipment was maintained by the Meadowbrook Dairy. The existing equipment being any antiquated paper chart recorder with float and pulley. To re-establish the monitoring station Stetson installed new monitoring and cellular telemetry components inside the stilling well. This work is summarized as a Memorandum submitted to the State Department of Water Resources, dated August 28, 2020.

The gaging station consists of a channel spanning compound rectangular weir. Upstream of the weirs a metal staff gauge is installed to measure weir stage height. Additionally, a perforated intake pipe is installed leading to an off-channel stilling well where the paper chart recorder and new monitoring equipment is installed. The monitoring and telemetry equipment consist of the following listed component parts:

Equipment List:

Part Number	Description
In-Situ 0099240	Level TROLL 400, Level Sensor Range – 11m, 35ft,(30 Psia)
In-Situ 0052000-05-01-08-00	Rugged Twist Lock Cable, Non-vented
In-Situ ISR-0000000-VL	VuLink Cellular Telemetry, 4G LTE, Antenna, GPS, 1.5-3.6V Li-MnO2 Battery, built in barometric sensor; HTTPS, FTP, SFTP, SMS, CSV file format
Proxicast ANT-121-002	Omni Antenna, 3G/4G/LTE, 3-5dBi

Photographs of Installation:



FIGURE 3. SAND CANYON STREAM GAGE SITE

Data Resolution & Telemetry Programming:

The In-Situ monitoring equipment, Level Troll 400 and Vulink device are programmed to record measured pressure (water and barometric pressure) values every 15-minutes, with barometric compensation made at the Vulink. The 15-minute time interval is based on the USGS stream gage standard. From there the Vulink cellular telemetry is programmed to upload the 15-minute readings to In-Situ's FTP server every 24 hours, or 96 readings. Stetson then retrieves the data from the FTP server for hosting on the IWVGSP.com web server.

Staff Gauge vs. Weir Stage:

During a December 2020 field visit where a level survey, and other verification measurements were completed, a 0.02-foot difference was recognized between the steel staff gauge and the actual weir crest. The staff gauge is installed with 0.02 feet reading equaling the

weir crest. Staff gage readings reported here are reflective of this 0.02-foot difference, and calculations of weir discharge utilize stage values 0.02 feet less than the staff readings.

Calculation of Discharge:

Calculation of stream discharge utilizes corrected stage measurements, recorded with the stilling well monitoring equipment, and the following equations (Francis Equation) to calculate discharge. These equations have been updated to reflect weir verification measurements taken during installation. The associated stage-discharge rating curve is shown below in Figure 4.

Discharge Equation(s) for Sand Canyon Compound Weir Structure

The discharge equation for the Sand Canyon stream gage includes the sum of the flow through the 2-foot and 12-foot weirs as described below.

2-foot Weir Component Discharge: $Q = 3.33 \times (L_1 - 0.02H_1) \times (H_1^{3/2})$

12-foot Weir Component Discharge: $Q = 3.33 \times (L_2 - 0.02(H_2 - 1)) \times ((H_2 - 1)^{3/2})$

Where:

Q = Discharge in cubic feet per second

L₁ = 2 feet; width of 2-foot weir

L₂ = 12 feet; width of 12-foot weir

H₁ = water stage height above 2-foot weir crest, in feet

H₂ = water stage height above 2-foot weir crest, when H is greater than 0.75, in feet

H_{max} = 2.25 feet, height of top of 12-foot high-flow weir

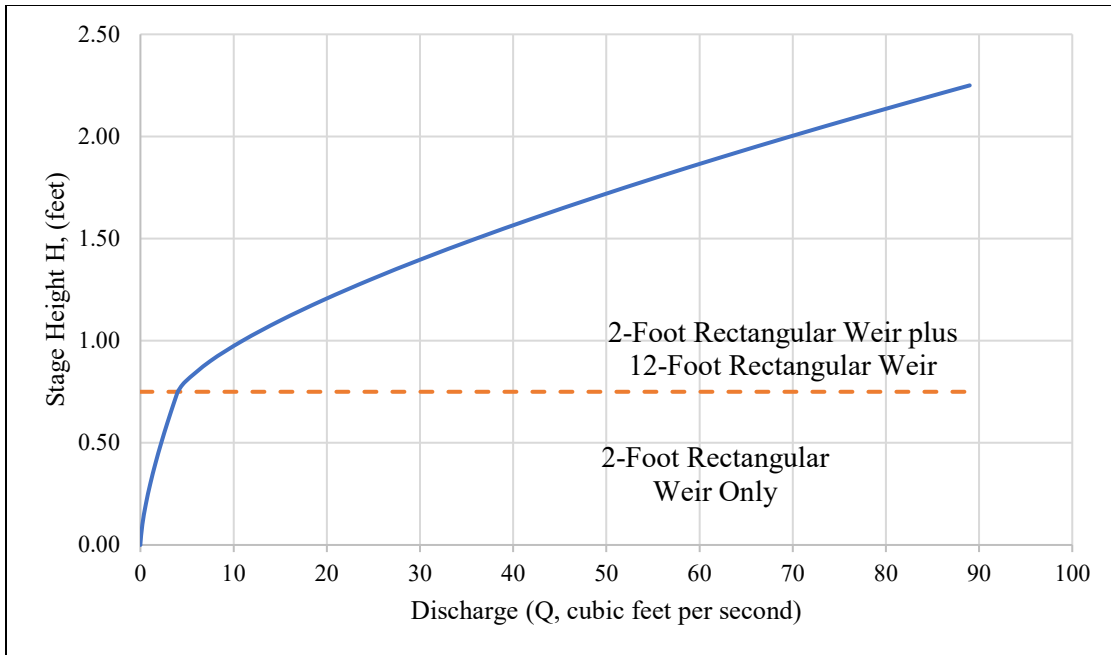

FIGURE 1. STAGE-DISCHARGE RATING CURVE FOR SAND CANYON WEIR STRUCTURE

The page intentionally blank

IWVGA ADMINISTRATIVE OFFICE

STAFF REPORT

TO: IWVGA Board of Directors **DATE:** March 27, 2024

FROM: IWVGA Staff

SUBJECT: Application for Shallow Well Mitigation Funding - Halpin

BACKGROUND

The Indian Wells Valley Groundwater Authority (IWVGA) has received a request for Shallow Well Mitigation Assistance from Sean Halpin. Mr. Halpin reports that the well for his residence on West Las Flores Avenue failed on September 7, 2023. Mr. Halpin is requesting funding assistance for the cost of a new well, which was installed in October 2023.

Under the Sustainable Groundwater Management Act (SGMA), Basin sustainability must be achieved by 2040. Groundwater levels will continue to decline until the management actions and projects in the California Department of Water Resources approved Groundwater Sustainability Plan (GSP) for the Basin are fully implemented. The GSP includes a program to help mitigate impacts to shallow wells during implementation of the GSP.

The Shallow Well Mitigation Program (Program) was approved by the Indian Wells Valley Groundwater Authority (IWVGA) Board at its February 10, 2021 meeting. The Program is implemented and managed by the Authority staff, under the direction of the Authority Board, on a “case-by-case” basis. The Program is essentially an “evaluation and potential mitigation reimbursement” process. The Program is dependent upon well owners voluntarily submitting information on their impacted wells for Authority consideration.

IWVGA has received four applications since the start of the program. One application was authorized funding of \$31,821 based on the “market value” of the original well plus the incremental cost of drilling a deeper well. IWVGA has recently approved an application for up to \$6,000 for Emergency Assistance.

This Report addresses Mr. Halpin’s application for the Primary Shallow Well Mitigation Program.

DISCUSSION

Mr. Halpin submitted an application to the IWVGA for the Program which was considered complete on December 1, 2023. The well was registered with IWVGA in 2019. The well is located on West Las Flores Avenue in Ridgecrest. The well was drilled in July 1972 to a depth of 300 feet and had a water level of 190 feet below ground surface (bgs). The well log indicates a perforated casing length of 90 feet which, assuming a 5-foot blank casing sump at the bottom of the well,

would mean the top of the perforated casing would be 205 feet bgs and the bottom of the perforated casing would be 295 feet bgs. The Halpin Well is currently 52 years old. Figure 1, attached, shows the well location. Mr. Halpin provided maintenance and well repair records.

In 2016, the well had trouble producing water due to a hole in the down hole drop pipe. Garrison Brothers Well Service measured only a few feet of water remaining in the bottom of the Well. Mr. Halpin opted not to rehabilitate but instead, to use the well for as long as possible. In 2019, Mr. Halpin experienced issues with the well and had it serviced by Boetsch Well Drilling & Pump Service. It was reported that the depth of the well was 267 feet and only had about 15 feet of water to the bottom of the well. The bottom 33 feet of the well apparently collapsed during the Ridgecrest earthquake. The drop in groundwater levels exposed the perforations in the well to the air for many years, which in the presence of water can induce rusting, which would have reduced the well's ability to withstand the earthquake. The pump was removed and replaced with a lower producing well pump to continue using the well. This enabled the well to continue producing water until September 2023.

Mr. Halpin reported the well stopped producing water on September 7, 2023. Garrison Brothers Well Service extracted the pump and found it operational but not pumping water and found the well had only 7 feet of water remaining. It is reported that the well had a water level of 252 feet bgs and a depth of 259 feet. The groundwater level declined by 62 feet since the well was constructed in 1972. Garrison Brothers Well Service determined the failure to be the lowering of the water table below the well pump resulting in the pump motor overheating.

Historical groundwater level data from the area is available from Well 26S/40E-31D02 and Well 26S/40E-31K01, located approximately 0.4 miles north and south, respectively, of the Halpin Well. The groundwater level data from Well 26S/40E-31D02 and Well 26S/40E-31K01, shown in Figure 2, indicates historically declining groundwater levels, although there has been some recovery in groundwater levels in recent years. On average, Well 26S/40E-31K01 and Well 26S/40E-31D02 have shown a decline of about 0.5 ft and 0.4 ft per year, respectively. The locations of Well 26S/40E-31D02, Well 26S/40E-31K01, and Mr. Halpin's well, along with contours of the groundwater surface elevations from the Spring of 2023 for the area are shown in Figure 3. The groundwater surface elevation contours demonstrate a depression in the area of the Halpin Well. There are about 21 other known de minimis wells and 2 non de minimis wells that are pumping from the same pumping hole.

An alternative to replacing the shallow well such as a potential new service connection to the Indian Wells Valley Water District (IWVWD) was investigated. The well lies within the IWVWD "service area" and its sphere of influence, as shown in Figure 4. IWVWD could connect to Mr. Halpin's property by running a line from Primavera Street to Las Flores Avenue. However, a replacement well has already been built which would not make this well a high priority for consolidation. There are other known wells within that area that are being considered for consolidation.

The Halpin Well was built 52 years ago, however a new pump was installed in 2019. Well owners are responsible for replacing a well when a well reaches the end of its useful life and no longer produces water, due to corrosion, well collapse due to corrosion or other factors. If a well no longer

produces water due to declining water levels, the IWVGA can consider paying a prorated cost based on the calculated life of the well. The Reproduction Cost New Less Accrued Depreciation (RCNLD) valuation method can be used to estimate the current value of water facilities, including wells. The estimated current “market value” of the Halpin Well is about \$10,012. The estimated incremental cost to drill a replacement “deeper” well (from the depth of the original well, 300 feet, to the depth of the new well, 500 feet) is about \$27,984. The IWVGA’s potential contribution to replace the Halpin Well with a deeper well (due to WL decline), based upon current market value of the Halpin Well is about \$37,996 (\$10,012 RCNLD + \$27,984 cost for deepening).

RECOMMENDED ACTION

Staff recommends approval of reimbursement of \$37,996 from the Shallow Well Mitigation Program to Mr. Halpin for well replacement due to declining groundwater levels.

The page intentionally blank

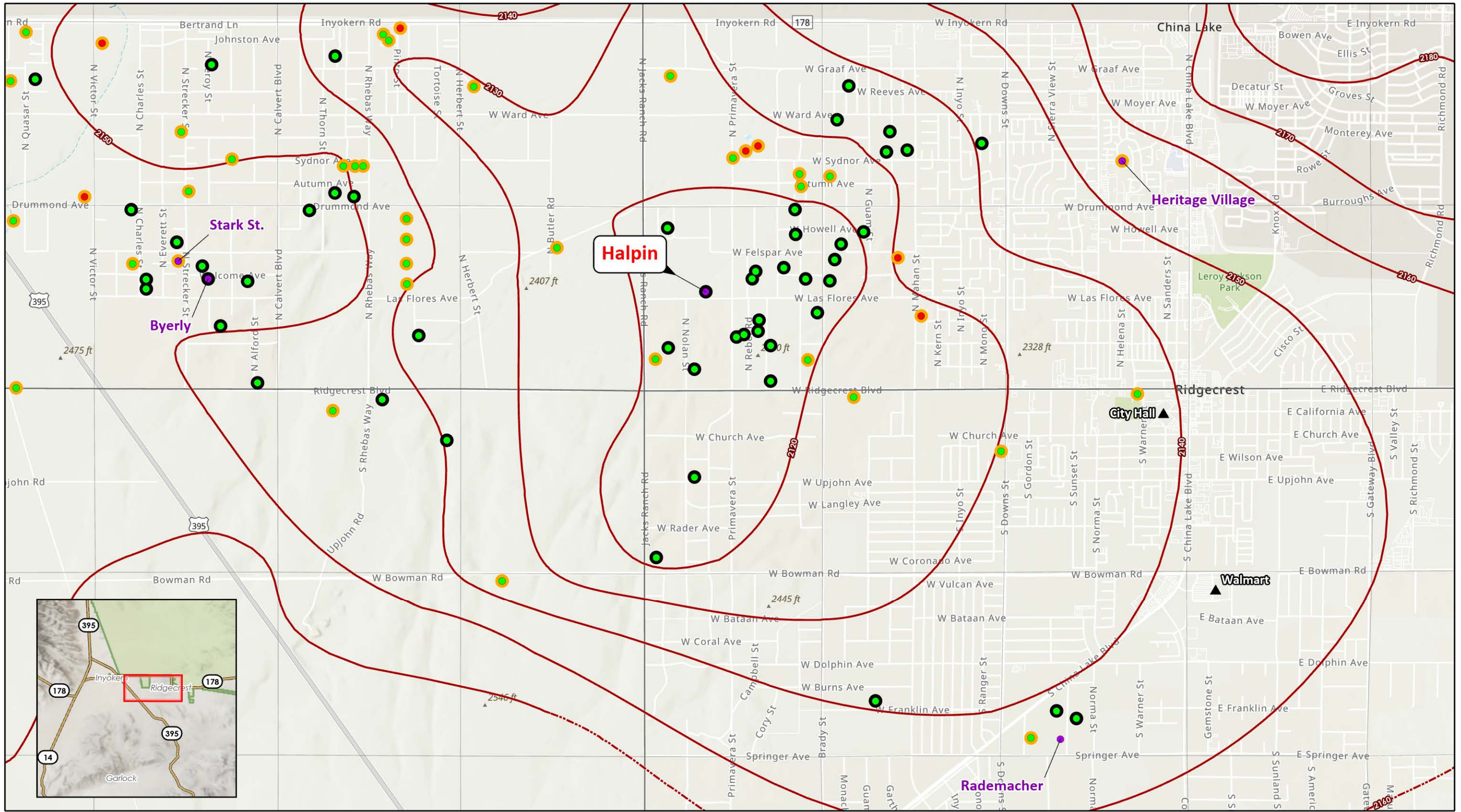

- ▲ Landmark
- De minimis
- Shallow Well
- Well Near Distribution System
- Non de minimis
- IWVWD Well

**HALPIN WELL LOCATION
INDIAN WELLS VALLEY**



Summary of IWV GA Shallow “de minimis” Groundwater Well Failure Due to Declining Water Levels and/or Declining Water Quality Occurring as a Result of Declining Water Levels

Subcommittee Recommendation Approved by Full Policy Advisory Committee September 28, 2023

Revised 1/9/24

1. **The definition of a “shallow well” and a “de minimis shallow well” are provided in this section, which would be incorporated into the IWVGA declining water level, failed well mitigation program.**
 - * The “de minimis shallow well” is a shallow well that is designed to produce a specific limited amount of groundwater. This well can have up to four separate de minimis connections, each using no more than 2 ac-ft per year. **It is this well type that is the subject of this document, as defined in California SGMA (Sustainable Groundwater Management Act). Over 90+ % of the IWV wells are de minimis.**
 - * A “shallow well” is defined as a well typically designed to produce a larger water quantity per year, as in a co-op or mutual water system. **The details of such a system often are more complicated technically and legally than a de minimis system and will be described separately from this document.** The mitigation of such a system at failure could involve a system redesign and reconstruction to enable combining with a neighboring system or joining a public water system.
 - * **No financial or legal discrimination is intended or implied in the separation into “de minimis shallow well” and “shallow well” types.**
2. **Typical de minimis shallow well casing design and depth.**
 - * A de minimis well is nearly always constructed with 6 inch *mild steel casing*, sometimes 8 inches, for shared wells. The well is usually 100 feet deeper than the *local* water table **based on the American Water Works Association (AWWA) A-100 guidelines. It is advisable in area of seriously declining water levels to drill deeper, perhaps providing 140’ or even more of standing water in a new well.**
3. **Typical screen design for a de minimis shallow well.**
 - * A de minimis well is typically provided with 40 feet of perforated section (the screen) at the bottom of the well casing. **Wells are often found in this Valley with a longer screen section but the additional screen usually served no good purpose. In fact, it directly reduces the life of the well (see Sec.5).**
4. **Typical pump and motor design for a de minimis shallow well.**
 - * A 1 or 1½ horsepower well pump and motor are sufficient for de minimis purpose with present day water depths. Somewhat larger pumps and motor are required for shared wells, up to 5 horsepower.
5. **De minimis shallow well failure. The IWV Groundwater Authority (GA) has authorized monetary compensation for failure of shallow de minimis wells which are directly related to declining groundwater levels or associated TDS (total dissolved solids) or specific EPA contaminant level increases in the pumped water (see further down in this section). The GA compensation might involve redrilling and sleeving the existing well or drilling a new deeper well.**
 - * **Assumed failure.** The groundwater level related well failures are commonly thought to be a *direct* result of the well groundwater level declining and *drying out the well*. **This virtually never happens in a water producing well as other failures will precede this point.**
 - * **The processes of mechanical failure** take a huge negative step when the pump is lowered (to stay covered as the water table declines) to the point that the *pump intake is within the casing perforations*. Depending upon the composition of the fines of the alluvial material outside of the casing (opposite the pump intake) the pump intake suction will draw in more or less sand and similar abrasive materials.

This sand can cause erosion and clogging of the perforations and pump intake screen and the pump itself and can cause pump failure in a relatively short time. ***This is a very serious well issue and often is the cause of immediate well failure.***

- * **The next potential corrosion failure step.** If the well water level continues to drop, it will eventually reach the top of the screen. At this point, exposure of the screen to the air will result in a *substantially accelerated* corrosion (rusting) of the perforated section of the well. **This step can result in casing failure.**
 - * **The corrosion failure from increasing TDS (total dissolved solids)** are more subtle and often involve corrosion pitting and even casing failure. Most wells are completed with a mild steel casing. **The failure of such a well commonly progresses from corrosion which is eating away the casing wall, to the point of casing collapse.** In this Valley, the causes are primarily due to i) high chloride and/or sulfate ion concentrations present in the groundwater at some locations or ii) the high iron/manganese in some groundwater that encourages growth of an iron bacteria that creates thick coatings of ferrous hydroxide. The coating is not uniform in thickness and the holes of the perforation section and the casing itself are weakened.
 - * **Well water chemistry and human health.** The TDS of the water pumped in most wells in the IWV is slowly increasing as the water table declines. **However, most IWV wells will ultimately fail from water level declines, not from increasing in TDS. Even if the increase in TDS does not cause casing corrosion failure, it may ultimately become a health issue.** Well owners who have a well which is producing high TDS water, should be vigilant in getting regular water chemistry analyses, especially if the water is high in iron, manganese or arsenic.
 - * **A well is declared in a human health failure condition, if the well water reaches the Primary Standards level of an Title 22 of the California Code of Regulations. If the well at a previous time was producing water at a lower contaminant level, it may be approved for GA mitigation. For more guidance see the Title 22 of the California Code of Regulations.** (The IWV Water District may provide sample containers and coordination of samples with a licensed laboratory they are using.)
6. **Well maintenance.** Much concern has been made of the maintenance that a well received. **It is very important for the well owner to have knowledge and understanding of his well, and its history.**
- * **It is the sole responsibility of the well owner to maintain the equipment in his well.** For a shallow domestic well the *only* maintenance usually made (or necessary) is to replace the pump and motor when a failure occurs in those components and to add a length of drop pipe and wire to the motor when it is replaced to keep up with declining water levels,
7. **Apportioning the cost of well repair.** Not all of the cost of well repair would be borne by the GA in their mitigation program. A prorated cost based on the calculated life of the well and other factors discussed above would be used to determine the GA financial contribution. **This is a complicated calculation and is often imperfect.**
- * **The physical life of a well** as actually observed can vary by a factor of nearly *ten* with the complex IWV Basin groundwater chemistries. If a well owner is willing to do a simple *video examination* of the subject failed well, much conjecture (and argument) can be eliminated. **Ultimately, the well owner still has the primary responsibility for the well.**
8. **A Report Form** that uses the factors described in this Committee Report would provide an accurate assessment of a failed well and should be a topic for the 2025 revisions to the GSP.

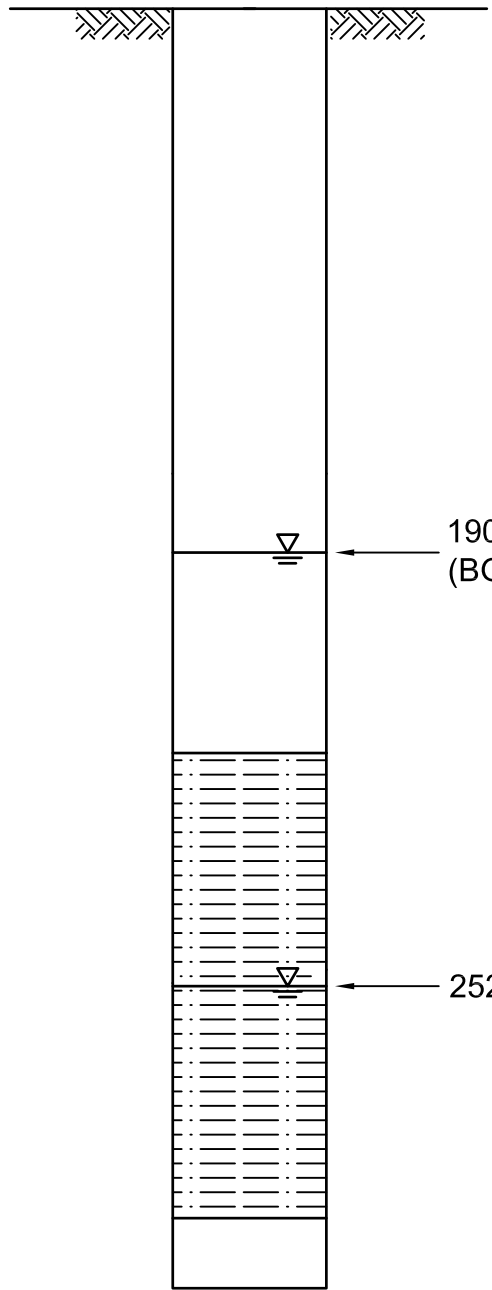

190' BELOW GROUND SURFACE
(BGS) IN 1972

252' BGS IN 2023

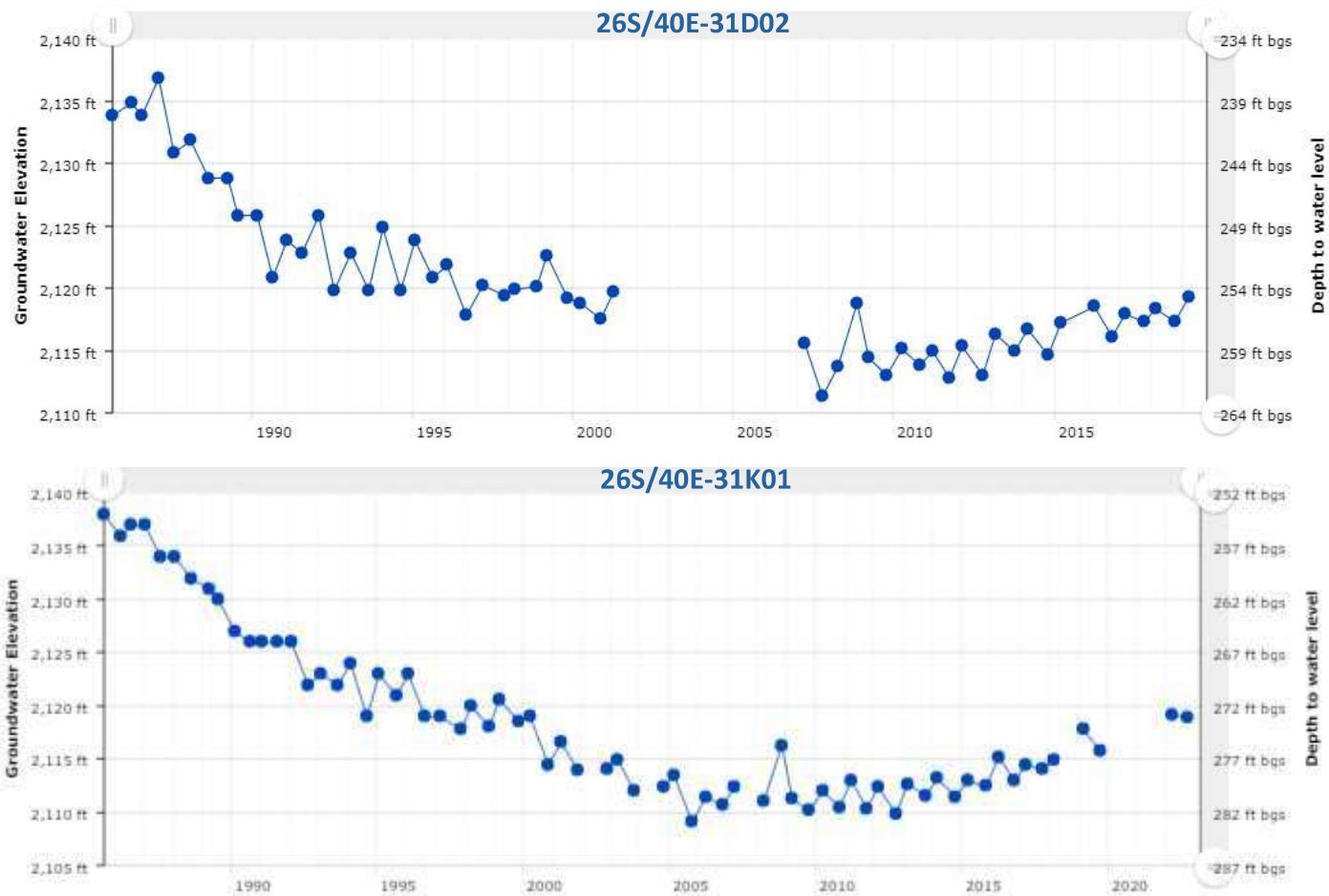

Land Surface Elevation = 2,288 feet above mean sea level.
 Source: Indian Wells Valley Groundwater Authority Data Management System.



STETSON ENGINEERS INC.

Covina San Rafael Mesa, Arizona

WATER RESOURCE ENGINEERS

**HYDROGRAPH FOR THE
 26S/40E-31D02 AND 26S/40E-31K01 WELL**

FIGURE 2

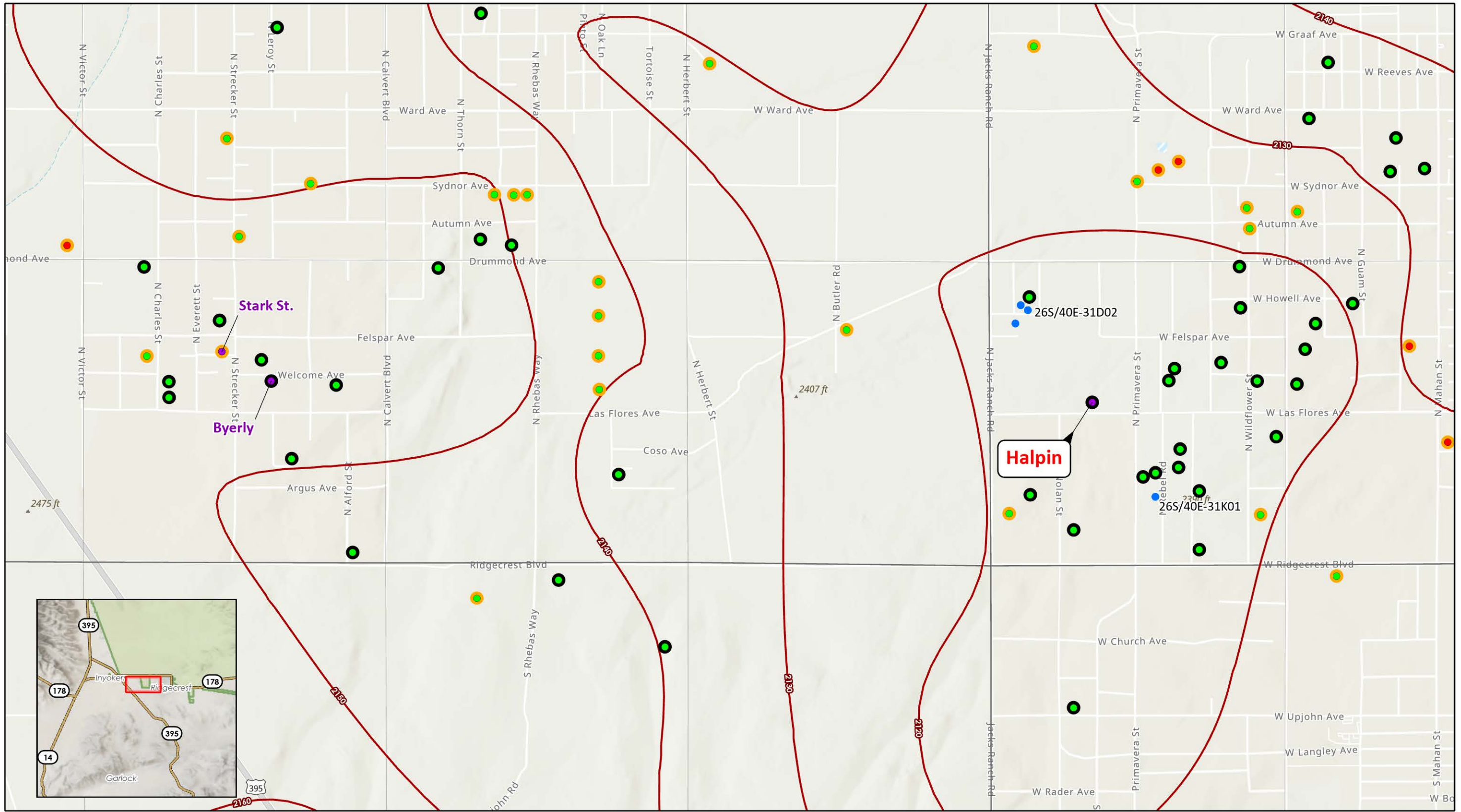

**GROUNDWATER LEVEL CONTOURS
INDIAN WELLS VALLEY**

- ▲ Landmark
- De minimis
- Well Near Distribution System
- Non de minimis
- IWVWD Well
- Shallow Well
- Monitoring Well

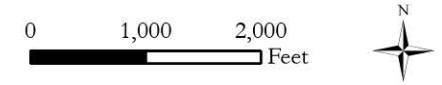

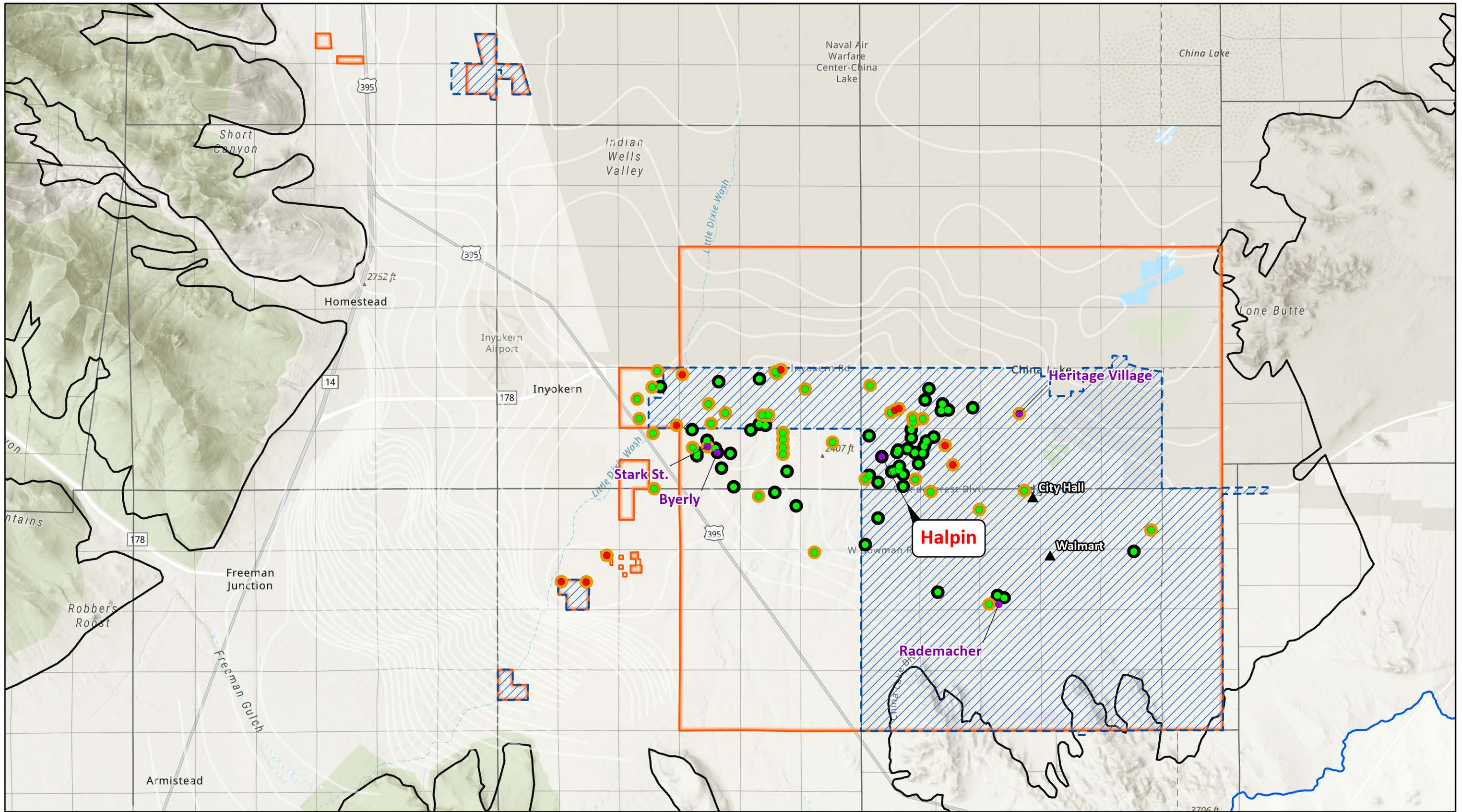

- ▲ Landmark
- Shallow Well
- Well Near Distribution System
- IWVWD Well
- De minimis
- Non de minimis
- Watershed Boundary
- Indian Wells Valley GSA
- IWVWD Sphere of Influence
- IWVWD Boundary

**INDIAN WELLS VALLEY WATER DISTRICT
AND SPHERE OF INFLUENCE
INDIAN WELLS VALLEY, CA**

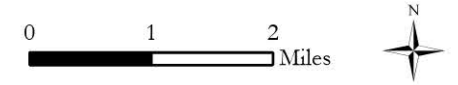

Document Path: I:\un652\WV_VD_Drv\Wells\spns\HalpinWell_IWVWD

The page intentionally blank

IWVGA ADMINISTRATIVE OFFICE

STAFF REPORT

TO: IWVGA Board of Directors **DATE:** March 27, 2024

FROM: IWVGA Staff

SUBJECT: Application for Shallow Well Mitigation Funding - Byerly

BACKGROUND

The Indian Wells Valley Groundwater Basin (Basin) has been in overdraft for several decades, resulting in a significant lowering of groundwater levels and reduction in the amount of useable groundwater in storage. Most of the wells impacted by the chronic decline in groundwater levels have been shallow wells (domestic and rural).

Under the Sustainable Groundwater Management Act (SGMA), Basin sustainability must be achieved by 2040. Groundwater levels will continue to decline until the management actions and projects in the California Department of Water Resources approved Groundwater Sustainability Plan (GSP) for the Basin are fully implemented. The GSP includes a program to help mitigate impacts to shallow wells during implementation of the GSP.

The Shallow Well Mitigation Program (Program) was approved by the Indian Wells Valley Groundwater Authority (IWVGA) Board at its February 10, 2021 meeting. The Program is implemented and managed by the Authority staff, under the direction of the Authority Board, on a “case-by-case” basis. The Program is essentially an “evaluation and potential mitigation reimbursement” process. The Program is dependent upon well owners voluntarily submitting information on their impacted wells for Authority consideration.

IWVGA has received four applications since the start of the program. One application was authorized funding of \$31,821 based on the “market value” of the original well plus the incremental cost of drilling a deeper well. IWVGA has recently approved an application for up to \$6,000 for Emergency Assistance.

This Report addresses Mr. Byerly’s application for the Primary Shallow Well Mitigation Program.

DISCUSSION

Mr. Byerly submitted an application to the IWVGA for the Program which was considered complete as of November 15, 2023. Mr. Byerly has applied for financial assistance through the Program to construct a new well, due to his existing well going dry in July 2023. The well, located on Welcome Avenue, is de minimis and is registered with the IWVGA. Figure 1, attached, shows the well location. Mr. Byerly doesn’t have any information on the well prior to purchasing the property in March of 2004 so the age of the well is unknown. However, based on the fact that Kern

County public property records indicate the house on the property was constructed in 1972, the age of well is assumed to be around 50 years old. The depth of the well is reported to be 343 feet below ground surface (bgs) based on prior well maintenance documents. A new pump and casing were installed in the well in March 2004 along with new wiring. At that time, the water level was at a depth of 294 feet bgs and the pump was set at 320 feet bgs.

When the well stopped producing water in July 2023, the static water level in the well was found to be 321 feet bgs, which was a decline of 27 feet since 2004. Mr. Byerly reported that the pump was replaced and lowered 15 feet. The cost for replacing and lowering the pump was \$8,788.97, which also included a flow restrictor and a pump saver controller. The well pump continued to break suction at the lower pump setting so a low flow restrictor was installed in line with the well pump in an attempt to lengthen the useful life of the well. A new pump saver controller was also installed to protect the well pump from overheating. The well produced 1 to 3 gallons per minute, but the pump continued to break suction. Garrison Brothers Well Services (License # 673398) recommended that the existing well be replaced in their report on the well dated November 2023. A permit for replacing the well was filed and the new well was finished in October 2023 at a cost of \$64,615.53. The new well was drilled to a depth of 515 feet bgs. The top and bottom of the perforated interval are 375 and 515 feet bgs, respectively. The static level was measured to be 321 feet bgs.

Historical groundwater level data from the area is available from Well 26S/39E-34D01, located approximately 3,900 feet northeast of Mr. Byerly's well. The groundwater level data from Well 26S/39E-34D01, shown in Figure 2, indicates historically declining groundwater levels. Another shallow well recently impacted by declining groundwater levels, the Stark Street Well, is located approximately 700 feet northeast of Mr. Byerly's well. The locations of Well 26S/39E-34D01, the Stark Street Well, and Mr. Byerly's well, along with groundwater surface elevation contours from the Spring of 2023 for the area, are shown in Figure 3.

Available water quality data for wells within the area indicated that there are no known water quality issues detected. The Stark Steet Well, about 700 feet northwest from the Byerly Well, was tested for Nitrates, Total Coliform, and E.coli in 2022 and results for those constituents did not exceed the Maximum Contaminant Level.

An alternative to replacing the shallow well such as a potential new service connection to the Indian Wells Valley Water District (I WVWD) was investigated. The I WVWD "service area" is close by but does not include the Byerly Well. The Byerly well is located within the District's sphere of influence but lies less than half a mile outside of the District's service area, as shown in Figure 4. A replacement well has already been built which would not make this well a high priority for consolidation with I WVWD. Potentially consolidating other shallow wells in this area into the I WVWD is being reviewed. I WVWD previously indicated that providing service to the area near the Byerly Well outside of its service area would require some time based on the ongoing process for the I WVWD to start providing water to the Dune 3 system. Once the Dune 3 system is integrated into the Water District, I WVWD could connect to the potential wells in the area by running a line from Strecker and Drummond to the well.

The Byerly Well is assumed to have been built around 50 years ago, however a new well casing was placed in the well in 2004 and the pump was replaced this year. Well owners are responsible for replacing a well when a well reaches the end of its useful life and no longer produces water, due to corrosion, well collapse due to corrosion or other factors. If a well no longer produces water due to declining water levels, the IWVGA can consider paying a prorated cost based on the calculated life of the well. The Reproduction Cost New Less Accrued Depreciation (RCNLD) valuation method can be used to estimate the current value of water facilities, including wells. The estimated current “market value” of the Byerly Well is about \$10,793. The estimated incremental cost to drill a replacement “deeper” well (from the depth of the original well, 343 feet, to the depth of the new well, 515 feet) is about \$20,289. The IWVGA’s potential contribution to replace the Byerly Well with a deeper well (due to WL decline), based upon current market value of the Byerly Well is about \$31,082 (\$10,793 RCNLD + \$20,289 cost for deepening).

RECOMMENDED ACTION

Staff recommends the approval of reimbursement of \$31,082 from the Shallow Well Mitigation Program to Mr. Byerly for well replacement due to declining groundwater levels.

The page intentionally blank

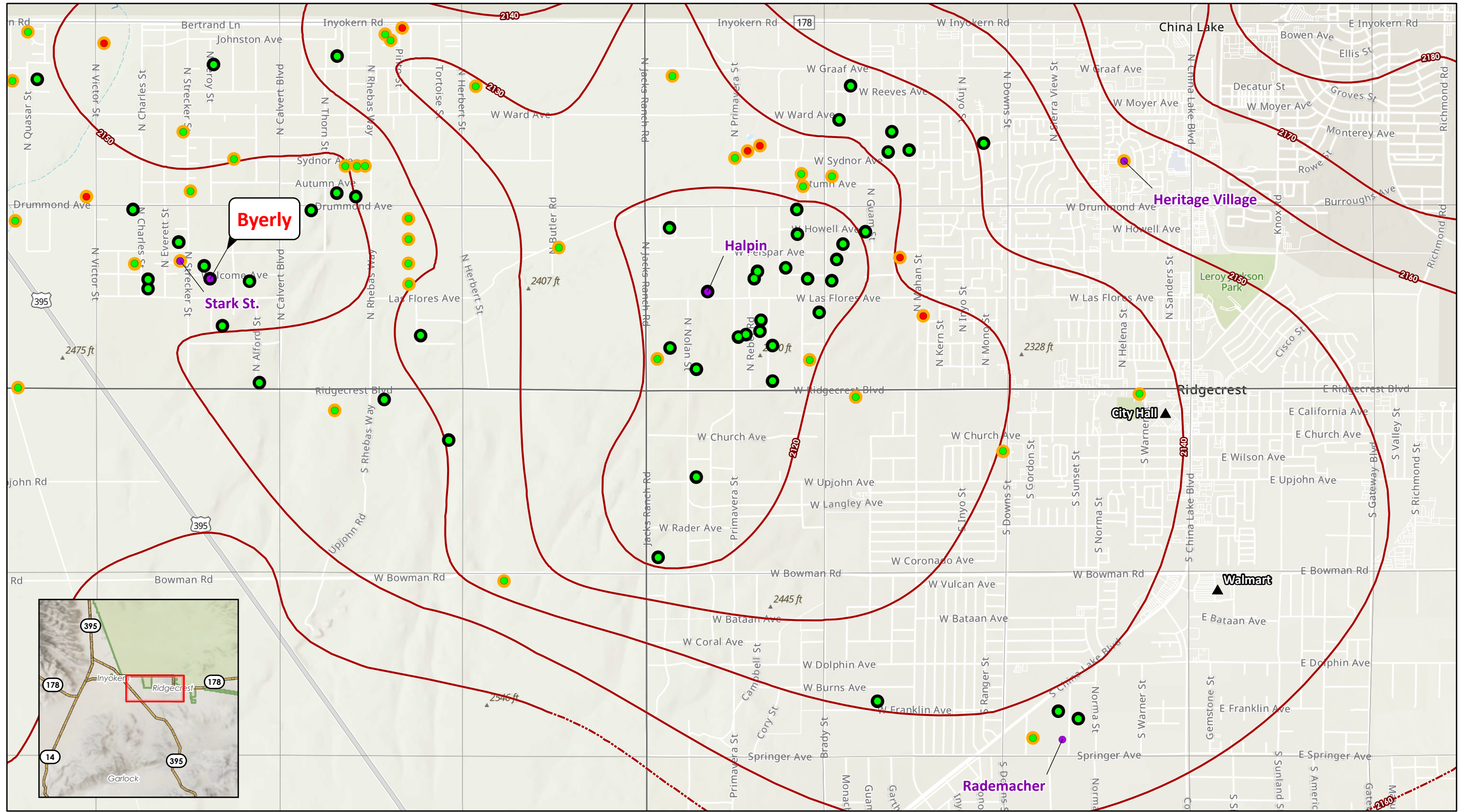

Document Path: I:\In\6521\WV_WD_Drv\Wells\mapx ByerlyWell_GW_Contours



- ▲ Landmark
- De minimis
- Shallow Well
- Well Near Distribution System
- Non de minimis
- IWVWD Well

**BYERLY WELL LOCATION
INDIAN WELLS VALLEY**



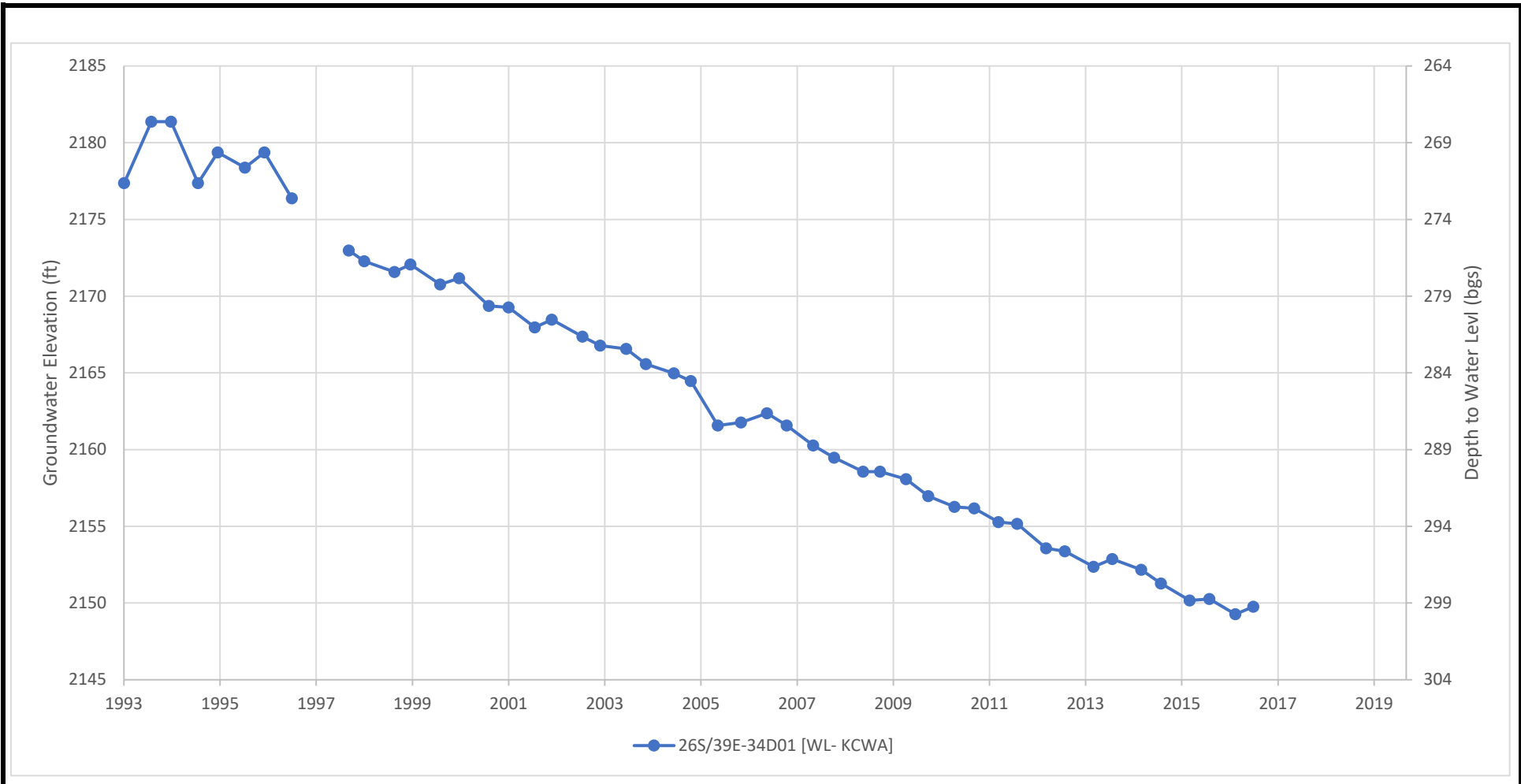

Land Surface Elevation = 2,448 feet above mean sea level.
 Source: Indian Wells Valley Groundwater Authority Data Management System.



STETSON ENGINEERS INC.
 Covina San Rafael Mesa, Arizona
 WATER RESOURCE ENGINEERS

**HYDROGRAPH FOR THE
 26S/39E-34D01 WELL**

FIGURE 2

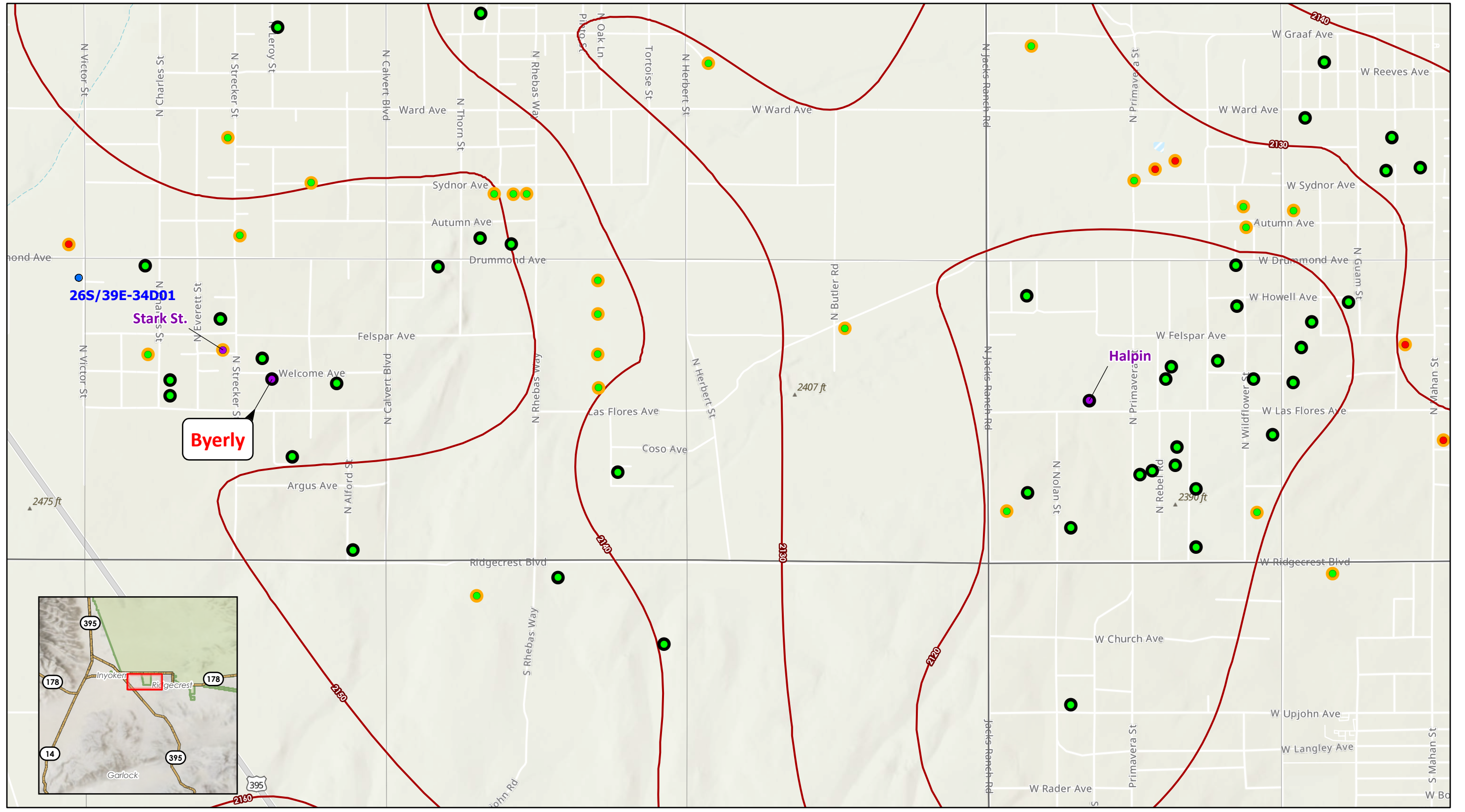

GROUNDWATER LEVEL CONTOURS
INDIAN WELLS VALLEY

- ▲ Landmark
- De minimis
- Well Near Distribution System
- Non de minimis
- IWVWD Well
- Monitoring Well
- Shallow Well

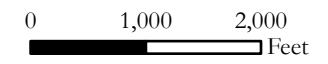

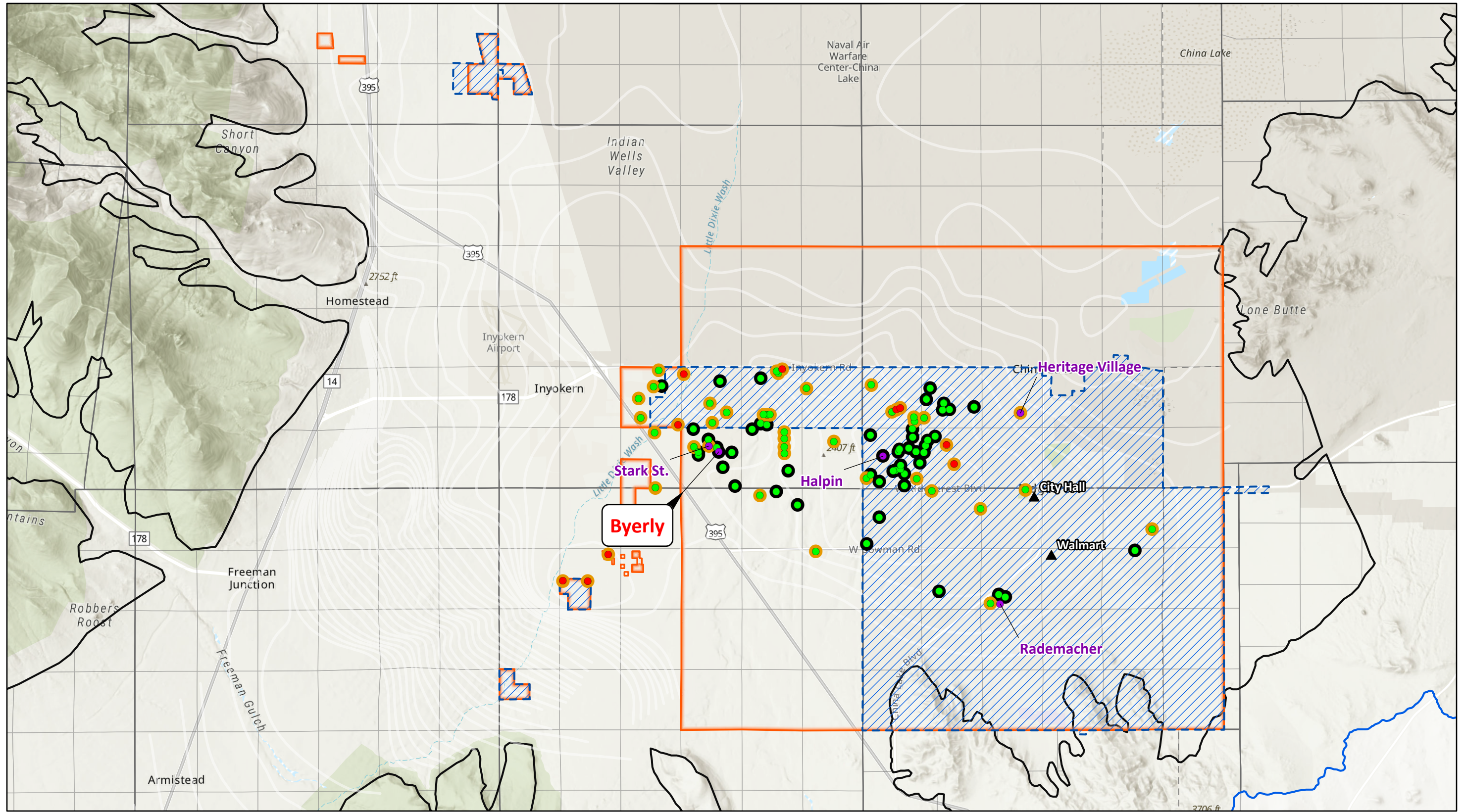

- ▲ Landmark
- Shallow Well
- Well Near Distribution System
- IWWVD Well
- De minimis
- Non de minimis
- Watershed Boundary
- Indian Wells Valley GSA
- IWWVD Sphere of Influence
- IWWVD Boundary

**INDIAN WELLS VALLEY WATER DISTRICT
AND SPHERE OF INFLUENCE
INDIAN WELLS VALLEY, CA**

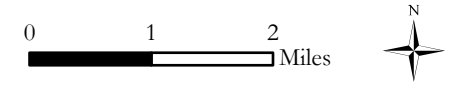

Document Path: I:\in662\I\WV_WD_Dev\Wells\arcx\ByerlyWell_IWWVD

The page intentionally blank

IWVGA ADMINISTRATIVE OFFICE

STAFF REPORT

TO: IWVGA Board Members **DATE:** March 29, 2024

FROM: IWVGA Staff

SUBJECT: **Agenda Item 11 – Approval of Change in Scope of Work and Budget for Contract with Provost and Pritchard Consulting Group for CEQA/NEPA Documents and Permit Documentation Services for the Imported Water Pipeline**

BACKGROUND

On February 28, 2023, the Indian Wells Valley Groundwater Authority (IWVGA) executed a Contract Services Agreement (CSA) for CEQA/NEPA Documents and Permit Documentation services for the Imported Water Pipeline Project (Project) with Provost and Pritchard Consulting Group (P&P). The CSA is funded by a \$7.6 million California Department of Water Resources Sustainable Groundwater Management Act Implementation Grant. The grant funds the planning and design-level activities for the Project which will bring imported water supplies into the Indian Wells Valley Groundwater Basin through a connection with Antelope Valley – East Kern Water Agency’s California City pipeline to the Indian Wells Valley Water District water system.

The Bureau of Land Management (BLM) has NEPA responsibility for this Project and Antelope Valley – East Kern Water Agency (AVEK) is the responsible agency under CEQA. As such, both BLM and AVEK have vested interests in ensuring that the strongest documentation and environmental review possible is done while also respecting and ensuring that the costs are appropriately constrained. With that said, the unreasonably litigious nature of some in this Basin has led to considerable and reasonable concerns by our partner agencies and the result is additional costs and sometimes redundant work as an insurance measure.

DISCUSSION

As discussed more thoroughly below, BLM and AVEK have made requests which will require additional work and changes in the original scope of work for this Project. Staff has reviewed the two requests described below and attached hereto. Staff has concluded that both requests are beneficial to the community and appropriate. The Bureau of Land Management request is largely redundant of work already completed and included in the original scope of work; however, additional Mapping, Assessment and Survey work will make for a stronger environmental document and as such the additional costs are reasonable insurance against any possible legal challenges. Similarly, the AVEK request is not required for this Project to move forward as presently planned but the additional studies will provide a stronger environmental document and as such the additional costs are reasonable insurance against any possible legal challenges. Moreover, both requests are in keeping with the Authority’s desire to ensure the Project is

accomplished with the utmost transparency and concern for the environment while being watchful of the costs to the community.

Bureau of Land Management Request:

Bureau of Land Management (BLM), which has independent NEPA responsibility for this Project, has requested additional work tasking which is more thoroughly described in the attachment titled Scope and Budget Amendment No 3. In sum, BLM has requested additional meeting coordination and biological resource tasks including Vegetation Mapping, Mohave Ground Squirrel Habitat Assessment, and additional botanical survey and reporting. South Environmental, a BLM authorized consulting firm, will map vegetation communities and identify any sensitive natural communities or unique plant assemblages. The communities will be assessed for the potential for Mohave Ground Squirrel presence. Additionally, a single botanical survey will be conducted in mid-April to early-May 2024, focused on rare plant habitat assessment and survey to identify special status plants that may occur in the Project area. A botanical survey report will be prepared that describes the methods and results of the survey.

The change in cost is \$52,800.00 the not-to-exceed value from \$1,175,598.00 to \$1,228,398.

Antelope Valley – East Kern Water Agency Request:

AVEK, which is the responsible agency under CEQA, has requested that the Authority add an additional Phase to the Project for CEQA analysis that includes an enlarged carrying capacity for the California City pipeline going back the AVEK tank farm. Importantly, it should be understood that the construction analyzed in this additional Phase is not presently required and there are no plans to construct this additional pipeline capacity at this time. However, as the review of this Project extends deep into the 45 year planning horizon there is the possibility that the current AVEK pipeline will need to be improved so that it may meet the peak demands of the Project and the other agencies served by AVEK through this connection at the outer planning horizon. Since the Indian Wells Valley will be an additional and new user of this pipeline the costs for any needed capacity improvements to this pipeline falls to the Authority. Accordingly, AVEK has requested the additional analysis because it will provide a stronger environmental document. Additionally, there are considerable costs savings to doing this Phased CEQA analysis now and there is the ancillary benefit of moving any future construction beyond the initial environmental review stage.

It should be noted that while the change in scope described in the attached Consultant Services Agreement is \$305,000, staff believes that this change is a financial benefit to the community because it will provide a stronger environmental document and the additional costs are reasonable insurance against any possible legal challenges.

RECOMMENDED ACTION

Staff recommends the Board approve the BLM and AVEK requested change in Scope of Work more thoroughly described in the attached Amendment 3 and the attached Consultant Services Agreement.

The page intentionally blank

PROVOST & PRITCHARD CONSULTING GROUP

400 E Main St, Ste 300 • Visalia, CA 93291 • (559) 636-1166
www.provostandpritchard.com

SCOPE & BUDGET AMENDMENT NO. 3

To:	Bianca Cabrera, Stetson Engineers, Inc.	Email:	BiancaC@stetsonengineers.com
From:	Dawn Marple, Principal Planner	Date:	March 22, 2024
Subject:	Indian Wells Valley Groundwater Authority Imported Pipeline Project CEQA/NEPA and Permitting Documentation: Contract Amendment No. 3		

A contract amendment is hereby submitted to Stetson Engineering Inc. for the Indian Wells Valley Groundwater Authority (IWVGA) Imported Pipeline Project California Environmental Quality Act (CEQA)/National Environmental Policy Act (NEPA) and Permitting Documentation Project (Job No. 4101-23-001) to incorporate the changes discussed below. This contract amendment is subject to the same terms and conditions of the original agreement for the project dated February 28, 2023.

TSK 1 – INITIAL COORDINATION

On February 2, 2024, it was determined by BLM that a dedicated note taker was needed for all meetings for the project moving forward. That dedicated note taker will be Jackie Lancaster, a Project Administrator at Provost & Pritchard. The amendment to this task is to cover her time to attend additional meetings and prepare notes for submittal to all present parties.

TSK 3 – TECHNICAL STUDIES

BLM is requiring additional biological resource task including Vegetation Mapping and MGS Habitat Assessment, and additional botanical survey and report. South Environmental, a BLM authorized consulting firm, will map vegetation communities and identify any sensitive natural communities or unique plant assemblages such as creosote rings or salt marsh. The vegetation communities will be characterized according to California Native Plant Society's The Manual of California Vegetation Online. The communities will be assessed for the potential for Mohave Ground Squirrel to occur and areas will be considered high, medium, low, or no potential for MGS based on the percentage of MGS target plants that occur in the community. A map will be created that shows the vegetation communities, any unique plant assemblages, and the MGS habitat assessment. The mapping will occur throughout the 180-foot-wide survey corridor and will be completed by stopping at each new plant community observed in the corridor to map the boundaries and assess the plant species density and composition. At a minimum the plant species composition and species list will be assessed every mile to assess the potential for MGS to occur when the community is continuous for large portions of the survey area. GIS shapefiles of the communities, unique plant assemblages, and MGS habitat assessment will be provided along with a pdf of the mapped areas.

A single botanical survey will be conducted, focused on rare plant habitat assessment and survey to identify special status plants that may occur on the survey area. The survey will include a single survey conducted in mid-April to early-May 2024 of the 180-foot-wide corridor that will be conducted according to CDFW 2018 Protocols for Surveying and Evaluating Impacts to Special Status Native Plant Populations and Sensitive Natural Communities and according to the USFWS 2000 Guidelines for Conducting and Reporting Botanical Inventories of Federally Listed, Proposed and Candidate Plants. The survey will include identification of all plant species encountered during the survey with a focus on those recorded in the region to the CNDDDB and CNPS Inventory of Rare and Endangered Plants, and the list of species provided by the BLM that may be found in habitats found on the survey area. Individual rare plants and populations will be recorded using a Trimble GPS and will be mapped. Prior to conducting the survey, South Environmental biologists will visit nearby reference sites to

determine if the target species are in bloom during the survey timing. A botanical survey report will be prepared that describes the methods and results of the survey.

BUDGET AMENDMENT			
Phase Name	Current Budget	Increase in Budget	Revised Budget
TSK 1 – Initial Project Coordination	\$139,755	\$10,800	\$150,555
TSK2 – Geotechnical Studies	\$150,480	-	\$150,480
TSK 3 – Technical Studies	\$355,040	\$42,000	\$397,040
TSK 4 – Public Outreach	\$98,235	-	\$98,235
TSK 5 – Regulatory Compliance	\$249,142	-	\$249,142
TSK 6 – CEQA/NEPA Documentation	\$182,946	-	\$182,946
Totals:	\$1,175,598	\$52,800	\$1,228,398
<i>Note:</i> 1) Current Budget includes increase from Amendments No. 1 & No. 2. Phases TSK2, TSK4, TSK5, & TSK6 are not requesting an increase at this time. 2) The amount of \$6,670.00 was pre-authorized in an email dated March 14 th , 2023, and is included as part of the overall budget increase in this amendment for Task 3.			

Please sign, date and return to Dawn E. Marple at Provost & Pritchard Consulting Group by emailing dmarple@ppeng.com, signifying approval of this Contract Amendment.

Client: Indian Wells Valley Groundwater Authority

By:

Name/Title: Carol Thomas-Keefer

Date Signed:

Provost & Pritchard Engineering Group, Inc. dba
 Provost & Pritchard Consulting Group

By: 

Name/Title: Heather Bashian,
 Director of Operations

Date Signed: March 22, 2024

The page intentionally blank

CONSULTANT SERVICES AGREEMENT

CSA NO:

Indian Wells Valley Groundwater Authority

Client/Agency

Carol Thomas-Keefer

Attention

Indian Wells Valley Groundwater Authority

Bill to

100 W. California Ave

Billing Address

Ridgecrest, CA 93555

City, Zip Code

Environmental Services for the Indian Wells Valley
Groundwater Authority, Antelope Valley-East Kern Water
Agency Mojave Tank Farm Alternative Analysis

Project Title

24-122

Proposal No.

(805) 764-5452

Telephone

Fax

cthomaskeefer@rgs.ca.gov

Email

Ridgecrest, California

Location

DESCRIPTION OF SERVICES

Please see attached proposal dated March 22, 2024.

The provisions set forth below and on the following paragraphs 1 through 42 are incorporated into and made a part of this Agreement. In signing, the Client acknowledges that they have read and approved all such terms and hires Provost & Pritchard Engineering Group, Inc., dba Provost & Pritchard Consulting Group, (Consultant) to perform the above described services.

TERMS AND CONDITIONS

Client and Consultant agree that the following terms and conditions shall be part of this agreement:

1. In providing services under this Agreement, the Consultant shall perform in a manner consistent with that degree of care and skill ordinarily exercised by members of the same profession currently practicing under similar circumstances at the same time and in the same or similar locality. The Consultant makes no warranty, express or implied, as to its professional services rendered under this Agreement.
2. Client acknowledges that Consultant is not responsible for the performance of work by third parties including, but not limited to, the construction contractor and its subcontractors.
3. Client agrees that if Client requests services not specified in the scope of services described in this agreement, Client will pay for all such additional services as extra services, in accordance with Consultant's billing rates utilized for this contract.

DOCUMENTS

4. Client acknowledges that all reports, plans, specifications, field data and notes and other documents, including all documents on electronic media, prepared by Consultant (collectively Work Product) are instruments of service which shall remain the property of Consultant and may be used by Consultant without the consent of Client. Consultant shall retain all common law, statutory law and other rights, including copyrights. Consultant grants Client a perpetual, royalty-free fully paid-up, nonexclusive and irrevocable license to copy, reproduce perform, dispose of, use and re-

use the Work Product in connection with the Project, in whole or in part, and to authorize others to do so for the benefit of Client. Client acknowledges that its right to utilize Work Product pursuant to this agreement will continue only so long as Client is not in default, pursuant to the terms and conditions of this agreement, and Client has performed all its obligations under this agreement.

5. Client agrees not to reuse Work Product, in whole or in part, for any project other than the project that is the subject of this agreement. Client further agrees to waive all claims against Consultant resulting in any way from any unauthorized changes or unauthorized reuse of the Work Product for any other project by anyone on Client's behalf. Client agrees not to use or permit any other person to use versions of Work Product which are not final and which are not signed and stamped or sealed by Consultant. Client shall be responsible for any such use of non-final Work Product. Client hereby waives any claim for liability against Consultant for use of non-final Work Product. If a reviewing agency requires that check prints be submitted with a stamp or seal, those shall not be considered final for purposes of this paragraph.
6. In the event Client (1) makes, agrees to, authorizes, or permits changes in Work Product, or (2) makes, agrees to, authorizes, or permits construction of such unauthorized changes, which changes are not consented to in writing by Consultant, or (3) does not follow recommendations prepared by Consultant pursuant to this agreement, resulting in unauthorized changes to the project, Client acknowledges that the unauthorized changes and their effects are not the responsibility of Consultant. Client agrees to release Consultant from all liability arising from such unauthorized changes, and further agrees to defend, indemnify and hold harmless Consultant, its officers, directors, employees and subconsultants from and against all claims, demands, damages or costs, including attorneys' fees, arising from such changes.
7. Under no circumstances shall delivery of Work Product for use by the Client be deemed a sale by the Consultant, and the Consultant makes no warranties, either express or implied, of merchantability and fitness for any particular purpose. In no event shall the Consultant be liable for indirect or consequential damages as a result of the Client's unauthorized use or reuse of the Work Product.
8. The Client is aware that differences may exist between electronic files delivered and the printed hard-copy construction documents. In the event of a conflict between the signed construction documents prepared by the Consultant and electronic files, the signed sealed hard-copy documents shall govern.

LIMITATIONS

9. Consultant makes no representations concerning soils or geological conditions unless specifically included in writing in this agreement, or by amendments to this agreement. If Consultant recommends that Client retain the services of a Geotechnical Engineer and Client chooses to not do so, Consultant shall not be responsible for any liability that may arise out of the making of or failure to make soils or geological surveys, subsurface soils or geological tests, or general soils or geological testing.
10. Client acknowledges that, unless specifically stated to the contrary in the proposal's description of services to be provided, Consultant's scope of services for this project does not include any services related in any way to asbestos and/or hazardous or toxic materials. Should Consultant or any other party encounter such materials on the job site, or should it in any other way become known that such materials are present or may be present on the job site or any adjacent or nearby areas which may affect Consultant's services, Consultant may, at its option, suspend or terminate work on the project until such time as Client retains a qualified contractor to abate and/or remove the asbestos and/or hazardous or toxic materials and warrant that the job site is free from any hazard which may result from the existence of such materials.

INDEMNIFICATION

11. To the fullest extent allowed by law, Consultant will indemnify and hold harmless, but shall have no duty to defend Client, its officers, directors, employees, and agents (collectively, the "Client indemnities") from, for and against any and all claims, demands, damages, losses, expenses, liabilities, and penalties arising out of or relating to the Project, but only to the extent caused by the negligent or other wrongful acts or omissions of Consultant, its subconsultants, or any person or entity for whose acts or omissions any of them are responsible, or by the failure of any such party to perform as required by this Agreement. To the fullest extent allowed by law, Client will indemnify and hold harmless, but shall have no duty to defend Consultant and its officers, directors, employees and agents from, for and against any and all claims, demands, damages, losses, expenses, liabilities and penalties arising out of or relating to

the Project, but only to the extent caused by the negligent or other wrongful acts or omissions of Client or any person or entity for whose acts or omissions it is responsible, or by the failure of any such party to perform as required by this Agreement. The obligations and rights of this Section are in addition to other obligations and rights of indemnity provided under this Agreement or applicable law.

FINANCIAL

12. All fees and other charges due Consultant will be billed monthly and shall be due at the time of billing unless specified otherwise in this agreement. If Client fails to pay Consultant within sixty (60) days after invoices are rendered, Consultant shall have the right in its sole discretion to consider such default in payment a material breach of this entire agreement, and, upon written notice, Consultant's duties, obligations and responsibilities under this agreement may be suspended or terminated for cause pursuant to Sections 26 through 31. In such event, Client shall promptly pay Consultant for all outstanding fees and charges due Consultant at the time of suspension or termination including all costs and expenses incurred in the performance of services up to suspension or termination.
13. Consultant shall not be liable to Client for any costs or damages that may result from the termination or suspension of services under this agreement due to Client's failure to pay Consultant invoices in accordance with the terms of this paragraph. In the event that Consultant agrees to resume terminated or suspended services after receiving full payment of all late invoices, Client agrees that time schedules and fees, as applicable, related to the services will be equitably adjusted to reflect any delays or additional costs caused by the termination or suspension of services.
14. In all cases where the proposal calls for payment of a retainer, that payment shall be made by Client to Consultant prior to commencement of services under this agreement. Upon receipt of retainer payment, the Consultant shall commence services as provided for under this Agreement. Unless otherwise provided for in the project proposal, such retainer shall be held by Consultant throughout the duration of the contract, and shall be applied to the final project invoice, and to any other outstanding AR, including late payment charges, on the project. Any amount of said retainer in excess of the final invoice and other outstanding AR shall be returned to the Client within 30 days of issuance of the final project invoice.
15. Client agrees that all billings from Consultant to Client will be considered correct and binding on Client unless Client, within ten (10) days from the date of receipt of such billing, notifies Consultant in writing of alleged inaccuracies, discrepancies, or errors in billing. In the event of a dispute over any billing or portion of billing, Client agrees to pay the undisputed portion of any billings in accordance with the payment terms set forth in Section 12.
16. Client agrees to pay a monthly late payment charge, which will be the lesser of one and one half percent (1-1/2%) per month or a monthly charge not to exceed the maximum legal rate, which will be applied to any unpaid balance commencing thirty (30) days after the date of the billing. Client acknowledges that payments applied first to unpaid late payment charges and then to unpaid balances of invoices.
17. In the event Consultant's fee schedule changes due to any increase of costs such as the granting of wage increases and/or other employee benefits to field or office employees or any taxes or fees imposed by local, state, or federal government on consultants' fees during the lifetime of this agreement, the new fee schedule shall apply to all subsequent work on time-and-materials contracts.
18. If payment for Consultant's services is to be made on behalf of Client by a third party lender, Client agrees that Consultant shall not be required to indemnify the third party lender, in the form of an endorsement or otherwise, as a condition to receiving payment for services. Client agrees to reimburse Consultant for all collection agency fees, legal fees, court costs, reasonable consultant staff costs and other expenses paid or incurred by Consultant in the event that collection efforts become necessary to enforce payment of any unpaid billings due to Consultant in connection with the services provided in this agreement.

LIMITATION OF LIABILITY

19. Notwithstanding any other provisions of this Agreement to the contrary, the aggregate liability of the Consultant under this Agreement, whether for breach of contract, tort, strict liability or any other legal theory, will not exceed the total amount of Consultant's compensation for performing services under this Agreement or \$50,000, whichever is greater, however this limitation of Consultant's liability does not apply to third-party claims, or to the Client's reasonable attorneys' fees and expert witnesses' fees and litigation expenses arising out of or related to such third-party claims for which Consultant is liable.

DISPUTE RESOLUTION

20. In an effort to resolve any conflicts or disputes that arise regarding performance under this agreement by either party, Client and Consultant agree that all such disputes shall be submitted to nonbinding mediation, using a mutually agreed upon mediation services experienced in the resolution of construction disputes. Unless the parties mutually agree otherwise, such mediation shall be a pre-condition to the initiation of any litigation. The parties further agree to include a similar mediation provision in their agreements with other independent contractors and consultants retained for the project and require them to similarly agree to these dispute resolution procedures. This provision shall not be interpreted to restrict the right of either party to file an action in a court of law, in the County of Fresno, State of California, having appropriate jurisdiction or to preclude or limit the Consultant's right to record, perfect or to enforce any applicable lien or Stop Notice rights.

CONSTRUCTION PROJECTS

21. If the scope of services contained in this agreement does not include construction phase services for this project, Client agrees that such construction phase services will be provided by Client or by others. Client assumes all responsibility for interpretation of the contract documents and for construction observation and supervision and waives any claim against Consultant that may in any way be connected thereto. In addition, Client agrees to indemnify and hold Consultant harmless from any loss, claim, or cost, including reasonable attorneys' fees and costs of defense, arising or resulting from the performance of such services by other persons or entities and from any and all claims arising from the modification, clarification, interpretation, adjustments or changes made to the contract documents to reflect changed field or other conditions, except for claims arising from the negligence or other wrongful acts of Consultant, its employees, its subconsultants, or any other person or entity for which Consultant is responsible.
22. Client agrees to include provisions in its contract with the construction contractor to the effect that in accordance with generally accepted construction practices, the construction contractor will be required to assume sole and complete responsibility for job site conditions during the course of construction of the project, including safety of all persons and property, and that this requirement shall apply continuously and not be limited to normal working hours. Neither the professional activities of Consultant nor the presence of Consultant or its employees or subconsultants at a construction site shall relieve the contractor and its subcontractors of their obligations, duties and responsibilities including, but not limited to, construction means, methods, sequence, techniques or procedures necessary for performing, superintending or coordinating all portions of the work of construction in accordance with the contract documents and applicable health or safety requirements of any regulatory agency or of state law.
23. Client agrees to require its contractor and subcontractors to review the plans, specifications and documents prepared by Consultant prior to the commencement of construction phase work. If the contractor and/or subcontractors believe there are deficiencies, conflicts, errors, omissions, code violations, or other deficiencies in the plans, specifications and documents prepared by Consultant, contractors shall notify Client so those deficiencies may be corrected or otherwise addressed by Consultant prior to the commencement of construction phase work.
24. If, during the construction phase of the project, Client discovers or becomes aware of changed field or other conditions which necessitate clarifications, modifications or other changes to the plans, specifications, estimates or other documents prepared by Consultant, Client agrees to notify Consultant and, at Client's option, retain Consultant to prepare the necessary changes or modifications before construction activities proceed. Further, Client agrees to require a provision in its construction contracts for the project which requires the contractor to promptly notify Client of any changed field or other conditions so that Client may in turn notify Consultant pursuant to the provisions of this paragraph.
25. If, due to the Consultant's error, omission or negligence, a required item or component of the Project is omitted from the Consultant's construction documents, the Consultant shall not be responsible for paying the cost required to add such item or component to the extent that such item or component would have been required and included in the original construction documents. The Consultant will not be responsible for any cost or expense that enhances the value of the Project.

SUSPENSION AND TERMINATION

26. If the Project or the Consultant's services are suspended by the Client for more than thirty (30) consecutive calendar days, the Consultant shall be compensated for all services performed and reimbursable expenses incurred prior to the receipt of notice of suspension. In addition, upon resumption of services, the Client shall compensate the

- Consultant for expenses incurred as a result of the suspension and resumption of its services, and the Consultant's schedule and fees for the remainder of the Project shall be equitably adjusted.
27. If the Consultant's services are suspended for more than ninety (90) days, consecutive or in the aggregate, the Consultant may terminate this Agreement upon giving not less than five (5) calendar days' written notice to the Client.
 28. If the Client is in breach of the payment terms or otherwise is in material breach of this Agreement, the Consultant may suspend performance of services upon five (5) calendar days' notice to the Client. The Consultant shall have no liability to the Client, and the Client agrees to make no claim for any delay or damage as a result of such suspension caused by any breach of this Agreement by the Client. Upon receipt of payment in full of all outstanding sums due from the Client, or curing of such other breach that caused the Consultant to suspend services, the Consultant shall resume services, and there shall be an equitable adjustment to the remaining project schedule and fees as a result of the suspension.
 29. Client acknowledges Consultant has the right to complete all services included in this agreement. In the event this agreement is terminated before the completion of all services, unless Consultant is responsible for such early termination, Client agrees to release Consultant from all liability for services not performed or completed by Consultant and from liability for any third-party reliance, use, interpretation or extrapolation of Consultant's work product. In the event all or any portion of the services by Consultant are suspended, abandoned, or otherwise terminated, Client shall pay Consultant all fees and charges for services provided prior to termination, not to exceed the contract limits specified herein, if any. Client acknowledges if the project services are suspended and restarted, there will be additional charges due to suspension of the services which shall be paid for by Client as extra services pursuant to Section 26. Client acknowledges if project services are terminated for the convenience of Client, Consultant is entitled to reasonable termination costs and expenses, to be paid by Client as extra services pursuant to Section 31.
 30. The Client may terminate this Agreement for the Client's convenience and without cause upon giving the Consultant not less than seven (7) calendar days' written notice.
 31. In the event of termination of this Agreement by either party, Consultant shall invoice Client for all outstanding services and expenses reasonably incurred by the Consultant in connection with the orderly termination of this Agreement, including but not limited to demobilization, reassignment of personnel, associated overhead costs and all other expenses directly resulting from the termination. The Client shall within thirty (30) calendar days of termination pay the Consultant for all services rendered and all reimbursable costs incurred by the Consultant up to the date of termination, in accordance with the payment provisions of this Agreement.

OTHER

32. This agreement shall be binding upon the heirs, executors, administrators, successors and assigns of Client and Consultant.
33. This agreement shall not be assigned by either Client or Consultant without the prior written consent of the other.
34. Consultant's or Client's waiver of any term, condition or covenant shall not constitute the waiver of any other term, condition or covenant. Consultant's or Client's waiver of any breach of this agreement shall not constitute the waiver of any other breach of the Agreement.
35. Client and Consultant agree that if any term or provision of this Agreement is determined to be illegal, in conflict with any law, void or otherwise unenforceable, and if the essential terms and provisions of this Agreement remain unaffected, then the validity of the remaining terms and provisions will not be affected and the offending provision will be given the fullest meaning and effect allowed by law.
36. This agreement shall be governed by and construed in accordance with the laws of the State of California. The Client agrees and consents to the exclusive jurisdiction of the courts of the State of California for all purposes regarding this Agreement and further agrees and consents that venue of any action brought hereunder shall be exclusively in the County of Fresno, State of California.
37. Within the limits of the approved scope and fee, Consultant may engage the services of any subconsultants when, in the Consultant's sole opinion, it is appropriate to do so. Such subconsultants may include testing laboratories, geotechnical engineers and other specialized consulting services deemed necessary by the Consultant to carry out the scope of the Consultant's services.

- 38. Consultant shall be entitled to immediately, and without notice, suspend the performance of any and all of its obligations pursuant to this agreement if Client files a voluntary petition seeking relief under the United States Bankruptcy Code or if there is an involuntary bankruptcy petition filed against Client in the United States Bankruptcy Court, and that petition is not dismissed within fifteen (15) days of its filing. Any suspension of services made pursuant to the provisions of this paragraph shall continue until such time as this agreement has been fully and properly assumed in accordance with the applicable provisions of the United States Bankruptcy Code and in compliance with final order or judgment issued by the Bankruptcy Court.
- 39. This agreement shall not be construed to alter, affect or waive any design professional's lien, mechanic's lien or stop notice right, which Consultant may have for the performance of services pursuant to this agreement. Client agrees to provide to Consultant the current name and address of the record owner of the property upon which the project is to be located. Client also agrees to provide Consultant with the name and address of any and all lenders who may loan money on the project and who are entitled to receive a preliminary notice.
- 40. Consultant shall not be liable for damages resulting from the actions or inactions of governmental agencies including, but not limited to, permit processing, environmental impact reports, dedications, general plans and amendments thereto, zoning matters, annexations or consolidations, use or conditional use permits, project or plan approvals, and building permits. Client agrees that it is the responsibility of Client to maintain in good standing all governmental approvals or permits and to timely apply for any necessary extensions thereof.
- 41. Consultant and Client each agree to waive consequential damages for claims, disputes or other matters in question arising out of or relating to this Agreement. This mutual waiver is applicable, without limitation, to all consequential damages due to either party's termination in accordance with paragraphs 26 through 31, except for termination expenses provided for in said paragraph 31. Client further agrees that to the fullest extent permitted by law, Consultant shall not be liable to Client for any special, indirect or consequential damages whatsoever, whether caused by Consultant's negligence, errors, omissions, strict liability, breach of contract, breach of warranty or other cause or causes whatsoever, including but not limited to, loss of use of equipment or facility, and loss of profits or revenue.
- 42. This Agreement is the entire Agreement between the Client and the Consultant. It supersedes all prior communications, understandings and agreements, whether oral or written. Amendments to this Agreement must be in writing and signed by both the Client and the Consultant.

Indian Wells Valley Groundwater Authority

Client/Agency

By

Name

Title

Date Signed

Provost & Pritchard Engineering Group, Inc.,
 dba Provost & Pritchard Consulting Group

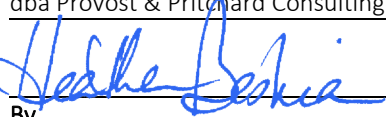

By

Heather Bashian, RCE 73075

Name

Director of Operations

Title

March 22, 2024

Date Signed

PROVOST&PRITCHARD CONSULTING GROUP

455 W Fir Ave • Clovis, CA 93611 • (559) 449-2700
www.provostandpritchard.com

March 22, 2023

Bianca Cabrera
Stetson Engineers, Inc.
861 Village Oaks Drive, Suite 100
Covina, CA 91724

Subject: Environmental Services for the Indian Wells Valley Groundwater Authority, Antelope Valley-East Kern Water Agency Mojave Tank Farm Alternative Analysis, Ridgecrest, California

Dear Bianca Cabrera:

Thank you for the opportunity to submit this proposal to provide environmental services for the subject project. This proposal discusses our understanding of the project, recommends a scope of services together with associated fees, deliverables and approximate schedules, sets forth our assumptions and discusses other services that may be of interest as the project proceeds.

PROJECT UNDERSTANDING

We understand that the Antelope Valley-East Kern Water Agency (AVEK) is requesting that the Indian Wells Valley Groundwater Agency (IWVGA/Authority) evaluate and analyze the alternative to connect to AVEK's Mojave Tank Farm at the same level, pursuant to the California Environmental Quality Act (CEQA) Guidelines and the National Environmental Policy Act (NEPA), as the California City Feeder for Imported Pipeline Project. The following scope of services would allow Provost & Pritchard (P&P) to completely analyze, including the completion of technical studies, the Mojave Tank Farm alternative throughout the Environmental Impact Report (EIR)/Environmental Assessment (EA).

SCOPE OF SERVICES

Our proposed scope of work for this proposal is segregated into several phases, described below.

PHASE TSK1: INITIAL COORDINATION

Coordinate with both Authority staff and Bureau of Land Management (BLM) regarding Project documentation and format. Coordination with the P&P Design team is also extremely important to continue analyzing CEQA/NEPA and incorporating the analysis of the Mojave Tank Farm Connection. Coordination efforts will occur throughout the Project duration.

- Coordination meetings with lead agencies for NEPA; and
- Meetings as needed with Federal, State, and local agencies.

PHASE TSK2: TECHNICAL STUDIES

Provost & Pritchard will team with South Environmental, EnviroPlus Consulting, ASM Affiliates, and AMBIENT to complete the technical studies. Navigating the complexities of CEQA/NEPA, especially with special-status-

\\ppeng.com\pzdata\docs\Marketing\Proposals\2024\Indian Wells Valley Groundwater Authority - AVEK Alternative 24-122\Working Drafts\2024-0322 AVEK Alternative Analysis Proposal_F.docx

species, including BLM sensitive species, requires an integrated team who can help guide design while successfully conducting environmental impact evaluations, and agency coordination from day one in order to avoid costly delays and/or avoidable impacts and mitigation. A solid Project area/area of potential effect must be finalized prior to any field surveys. Our team will leverage our expertise to identify potential environmental issues that could result in complex or time-consuming permitting. These considerations will be used to initiate early agency coordination, and aid in developing and maintaining the Project schedule, while maximizing efficiency and minimizing the risk of unexpected schedule delays.

BIOLOGICAL RESOURCES TECHNICAL STUDIES

Implementing baseline biological surveys as soon as possible is critical not only for refining pre-construction requirements during agency consultations, but also current climatic conditions. In order for protocol level and botanical surveys to be accepted during the permitting phase of a Project, they must be conducted under appropriate ecological conditions. Rainfall is critical for species of concern in this region, including desert tortoise, burrowing owl, Mohave ground squirrel, and rare botanical species. Initiating surveys in early Spring 2024, given the amount of rainfall this winter, would avoid potentially year-long delays when conditions are too dry to appropriately determine the presence or absence of these protected special status species. Historical data and large-scale projects previously implemented in the region indicate that agencies will require these biological surveys. Completing this work in advance of agency consultation will convey that the Project proponent is taking all necessary actions to accurately determine potential environmental impacts and to mitigate those impacts, which will ultimately ensure a smoother permitting process and avoid delays.

- Provost & Pritchard staff, with support from EnviroPlus Consulting desert tortoise expert, will perform a reconnaissance-level, desert tortoise protocol-level survey and burrowing owl habitat analysis upon notice to proceed.
- South Environmental will perform protocol level rare plant surveys and vegetation mapping field surveys upon notice to proceed.
- Goals of the biological field surveys consist of identification of existing biological resources within the Project area, including land uses and biotic habitats, constituent plants and animals, and suitable habitat for special status species. Biological information of the Project area will be built from the information previously gathered during the alignment study and will be utilized to expedite the surveys.
- The botanical survey team understands that the Project consists of the approximately 24-mile-long initial preferred point of connection to the current alignment with a 105-foot buffer on either side, creating a 210-foot-wide survey corridor. Thus, the proposed Project totals approximately 1,270-acres to be surveyed, with survey widths varying dependent on some existing limitations (e.g., ditches, fencing, etc.).
- The desert tortoise surveys will be performed according to guidelines within the *Preparing For Any Action That May Occur Within The Range Of The Mojave Desert Tortoise (Gopherus agassizii)* along the additional 24-mile segment that would connect to the current alignment.
- Prepare a Biological Evaluation/Biological Assessment (BE/BA) report evaluating potential Project impacts to state and federally listed or special status species, habitats, and other sensitive biological resources. The reports will be consistent with CEQA/NEPA standards including Sections 7 consultation language and will be suitable for submission to the regulatory permitting agencies.
- Mitigation measures will be identified for potentially significant impacts.
- The team will assist the BLM with Federal ESA Section 7 consultation and will provide the BE/BA for submittal to USFWS. The reports will apply the best available science and tools and will include a project description; a defined action area; species and/or critical habitat descriptions and

potential project-related effects (including direct, indirect, and cumulative); avoidance and minimization measures; and provide effective determination statements.

- California ESA generally parallels the main provisions of the federal ESA. California ESA consultation with CDFW for the proposed action, and the resultant California ESA applications lead to issuance by CDFW of either a Consistency Determination or Incidental Take Permit. If there is a potential for take or adverse effects of a species listed under both the federal and State ESA, a Consistency Determination would be requested. However, if the team identifies the potential for take of a State-listed (non-federally listed) species, a separate Incidental Take Permit will be sought.
- Our biologists will establish the baseline conditions of the Project alignment by conducting reconnaissance-level field surveys to verify/refine desktop vegetation mapping products and assess if special-status species and/or their habitats have the potential to occur within the biological study area.
- Following completion of the reconnaissance-level field surveys, the team will work with Authority and BLM to identify strategies to avoid or minimize potential impacts. Based on past experiences with other projects, avoidance and/or minimization measures may include working with the design team to provide refinement as well as construction practices. We have found that for similar projects even minor adjustments to project designs (e.g., slightly adjusting staging area boundaries) can greatly minimize impacts on sensitive resources.
- Following completion of the survey efforts, the team will facilitate a field site visit with Authority, the BLM and other key agency representatives (e.g., CDFW and USFWS). Our Team has often facilitated site visits on other projects (e.g., Pacheco Reservoir Expansion Project, Friant Kern Canal Middle Reach Capacity Correction Project) to encourage dialogue with the involved agencies; introduce them to the Project and the core Project team members; and proactively identify issues or concerns these agencies may have. Early identification of key issues helps to inform mitigation and/or minimization strategies in the official reports and establish rapport with the regulatory agencies to streamline and expedite the consultation process.

DELIVERABLES:

- Reconnaissance-level Biological Survey BE/BA Report;
- Protocol-level Pre-Project Desert Tortoise Survey Report;
- Vegetation Mapping and MGS Habitat Assessment Report; and
- Special Status Botanical Survey Memoranda.

DESERT TORTOISE PRE-PROJECT SURVEY

EnviroPlus Consulting, LLC (EPC) would provide two USFWS-qualified desert tortoise surveyors to help conduct the pre-project desert tortoise survey. The survey is anticipated to take one week.

VEGETATION MAPPING AND MGS HABITAT ASSESSMENT

South Environmental will map vegetation communities and identify any sensitive natural communities or unique plant assemblages such as creosote rings or salt marsh. The vegetation communities will be characterized according to California Native Plant Society's The Manual of California Vegetation Online. The communities will be assessed for the potential for Mohave Ground Squirrel to occur and areas will be considered high, medium, low, or no potential for MGS based on the percentage of MGS target plants that occur in the community. A map will be created that shows the vegetation communities, any unique plant assemblages, and the MGS habitat assessment. The mapping will occur throughout the 180-foot-wide survey corridor and will be completed by stopping at each new plant community observed in the corridor to map the

boundaries and assess the plant species density and composition. At a minimum the plant species composition and species list will be assessed every mile to assess the potential for MGS to occur when the community is continuous for large portions of the survey area. GIS shapefiles of the communities, unique plant assemblages, and MGS habitat assessment will be provided along with a pdf of the mapped areas.

BOTANICAL SURVEY AND REPORT

South Environmental will conduct a single botanical survey focused on rare plant habitat assessment and survey to identify special status plants that may occur on the survey area. The survey will include a single survey conducted in mid-April to early-May 2024 of the 180-foot-wide corridor that will be conducted according to CDFW 2018 Protocols for Surveying and Evaluating Impacts to Special Status Native Plant Populations and Sensitive Natural Communities and according to the USFWS 2000 Guidelines for Conducting and Reporting Botanical Inventories of Federally Listed, Proposed and Candidate Plants. The survey will include identification of all plant species encountered during the survey with a focus on those recorded in the region to the CNDDDB and CNPS Inventory of Rare and Endangered Plants, and the list of species provided by the BLM that may be found in habitats found on the survey area. Individual rare plants and populations will be recorded using a Trimble GPS and will be mapped. Prior to conducting the survey, South Environmental biologists will visit nearby reference sites for the original project to determine if the target species are in bloom during the survey timing. A botanical survey report will be prepared that describes the methods and results of the survey.

CULTURAL AND TRIBAL RESOURCES

ASM will obtain a Fieldwork Authorization from the Bureau of Land Management prior to any field surveys.

ASM will request a search of maps and files from the local Information Center in order to identify previously recorded sites and previous cultural resource studies documented within a half-mile radius of the project site. We will also request a search of the Sacred Lands File be conducted by the Native American Heritage Commission (NAHC) in order to identify any areas of Native American heritage significance. The NAHC will provide a list of tribal contacts that may have further information regarding the Project area. ASM will also send notification letters to the tribal contacts but would not participate in consultation and assumes this will be conducted by the lead agency.

ASM will conduct an intensive pedestrian field survey of the 24-mile pipeline route with an expected 125-ft buffer. The total survey area is expected to be 730-acres. ASM may be required to retain a Native American monitor to accompany ASM's archaeologists during the field survey.

ASM will prepare a report containing the requisite written documentation in compliance with the NHPA/CEQA process that will include a historic overview, methodology, survey findings, identification of known historical resources, recommended mitigation and/or provide recommendations for any further work required for compliance.

DELIVERABLE

- Technical Report/Memo documentation in compliance with the NHPA/CEQA

AIR QUALITY AND GREENHOUSE GAS, IMPACT ASSESSMENT

AMBIENT Air Quality & Noise Consulting will update the Air Quality & Greenhouse Gas (GHG) Impact Assessment prepared for the proposed project to include evaluation of an additional alternative to include connection to AVEK's Mojave Tank Farm. This update will include quantification of short-term construction emissions associated with the proposed alternative alignment. Emissions of criteria air pollutants and GHG emissions will be quantified utilizing the most recent California Emissions Estimator Model (CalEEMod)

computer program. Emissions will be quantified based on project-specific construction information and schedules, to be provided. Revisions to the analysis of long-term operational emissions, localized pollutant concentrations, including carbon monoxide, particulate matter, and air toxics are not anticipated to be required and are not included. This scope of work does not include dispersion modeling of localized pollutant concentrations or the preparation of health risk assessments. The qualitative discussion of the proposed project's consistency with applicable air quality attainment/maintenance plans and GHG-reduction plans will be reviewed in comparison to currently adopted plans and updated to the extent necessary. If necessary, proposed mitigation measures will be updated.

AIR QUALITY GENERAL CONFORMITY ANALYSIS

Proposed projects that require Federal approval or funding are subject to Federal Air Quality Conformity requirements. In accordance with Federal requirements, the Air Quality General Conformity Analysis previously prepared for the project will be updated to include construction-generated emissions associated with the AVEK's Mojave Tank Farm alignment alternative. Project-generated emissions will be compared to Federal de minimis thresholds. Mitigation measures will be updated and quantitatively assessed to the extent necessary. This scope of work assumes that a separate public review period for air quality conformity would not be required.

DELIVERABLE

- Air Quality and Greenhouse Gas Impact Analysis (Report)

ENERGY USE IMPACT ASSESSMENT

AMBIENT Air Quality & Noise Consulting will update the Energy Use Impact Assessment to include evaluation of an additional alternative to include connection to AVEK's Mojave Tank Farm. This update will include evaluation of construction energy use associated with the proposed AVEK's Mojave Tank Farm alignment alternative. Construction-related fuel use will be quantified based, in part, on the CalEEMod emissions modeling conducted for this project. Revisions to the long-term operational energy use impact discussion/analysis is not anticipated to be required and is not included. Recommended mitigation measures and consistency with applicable regulatory requirements for energy conservation will be reviewed and updated to the extent necessary.

DELIVERABLE

- Energy Impact Assessment (Report)

NOISE AND GROUND BORNE VIBRATION IMPACT ASSESSMENT

The Noise and ground borne Vibration Impact Assessment will be updated to include the proposed AVEK's Mojave Tank Farm alignment alternative. The location of proposed stationary equipment (e.g., pump stations) associated with this alternative will be reviewed. The analysis of long-term operational impacts will be updated to the extent deemed necessary. Revisions to the analysis of short-term construction noise impacts, vibration impacts, and recommended mitigation measures are not anticipated to be required.

DELIVERABLE

- Noise and Ground Borne Vibration Impact Analysis (Report)

PHASE TSK3: CEQA_NEPA COMPLIANCE

Provost & Pritchard is in the process of completing the Environmental Impact Report/Environmental Analysis (EIR/EA) for the Central Alignment (proposed project). P&P will utilize the technical studies, as outlined above to analyze the Mojave Tank Farm Alternative at the same level as the proposed project within the EIR/EA.

The incorporation of this analysis will be included in the EIR/EA for the proposed project. There will not be any separate deliverables other than those described above for the technical studies and those described in the approved scope of work for the Indian Wells Valley Groundwater Authority – Imported Pipeline Project dated February 28, 2023.

PROFESSIONAL FEES

Provost & Pritchard Consulting Group will perform the services in this Phase on a time and materials basis, in accordance with our Standard Fee Schedule in effect at the time services are rendered. The following fees will be invoiced monthly as they are accrued. Reimbursable expenses will be invoiced in addition to professional fees and are included in the estimated ranges above. If it appears we will need to exceed the fees estimate below, we will notify you in writing before we do so and will provide a revised estimate. We will not continue to work beyond the initial budget without additional authorization.

MOJAVE TANK FARM ANALYSIS	
PHASE	ESTIMATED FEE
Phase TSK1 Initial Coordination	\$51,000
Phase TSK2 Technical Studies	\$211,000
Phase TSK3 CEQA_NEPA Compliance	\$43,000
Total Estimated Fee:	\$305,000

SCHEDULE

This proposal would serve as an amendment to our signed contract February 28, 2023. This work effort would extend passed the current grant deadline and an official grant extension request would need to occur prior to the incorporation of this work effort into the EIR/EA. Once we receive an executed copy of this Proposal together with an authorized to notice to proceed, P&P will work with the Authority to prepare an appropriate schedule to analysis this alternative. Any required Agency review time is beyond our control.

ASSUMPTIONS

- Grant deadline will get extended passed current deadline to allow for the technical studies and analysis of this alternative connection to the Central Alignment (proposed project);
- All cultural services will be provided in compliance with local agency requirements and NHPA/CEQA;
- Indirect impacts analysis is not required;
- No built environment analysis will be required;
- No geoarchaeological study will be required;
- The cost of the records search will not surpass \$3,000.00;
- No more than 20 archaeological sites will be identified within the survey area by the records search;
- No more than 5 archaeological sites will be identified and recorded during survey;
- All deliverables will be provided electronically;

- An Aquatic Resources Delineation is not included as part of this proposal and will be required prior to construction if this alternative connection is selected and approved to be part of the overall alignment;
- Permitting efforts are not included as part of the analysis for this alternative.
- Geotechnical efforts are not included as part of the analysis for this alternative

TERMS AND CONDITIONS

In order to convey a clear understanding of our mutual responsibilities under this proposal, our standard Consultant Services Agreement is attached. Please sign both of these documents and mail or email a copy to our office along with an official Notice to Proceed. This proposal is valid for 30 days from the date above.

Sincerely Yours,
Provost & Pritchard Consulting Group



Dawn E. Marple, Environmental Project Manager
Principal Planner



Heather Bashian, RCE 73075
Director of Operations

TERMS AND CONDITIONS ACCEPTED

By Indian Wells Valley Groundwater Authority

Signature

Printed Name

Title

Date

The page intentionally blank

IWVGA ADMINISTRATIVE OFFICE

STAFF REPORT

TO: IWVGA Board Members **DATE:** March 13, 2024
FROM: IWVGA Water Resources Manager
SUBJECT: AGENDA ITEM 12 – WATER RESOURCES MANAGER’S REPORT

AGENDA ITEM 12a – GRANT FUNDING UPDATE

Proposition 1 Update

- Invoice #16a
 - Covers July 2022 through September 2022
 - Total requested payment after retention: \$20,806.59
 - Status: Payment Received
- Invoice #17a:
 - Covers October 2022 through December 2022
 - Total requested payment after retention: \$7,817.63
 - Status: Payment Received.

Proposition 1/68 Grant Closeout

- Retention invoices for Proposition 1 and Prop 68 in the amount of \$187,678.87 and \$32,941.39, respectively, were submitted to DWR on February 28, 2023. The Proposition 1 retention invoice was revised and resubmitted on May 18 per DWR’s request.

SGMA Implementation Round 1 Update

- Invoice #3
 - Covers January 2023 through March 2023
 - Total requested payment: \$417,072.61
 - Comments received from DWR on initial submittal
 - Status: Approved and awaiting payment
- Invoice #4
 - Covers April 2023 to June 2023
 - Total requested payment: \$1,061,117.14
 - Comments received from DWR on initial submittal
 - Status: Approved and awaiting payment
- Invoice #5
 - Covers July 2023 to September 2023
 - Total requested payment: \$851,669.63
 - Comments received from DWR on initial submittal
 - Status: Approved and awaiting payment

- Invoice # 6
 - Covers October 2023 to December 2023
 - Total requested payment: \$626,069.10
 - Status: Approved and awaiting payment

Urban Community Drought Relief Program Update

- The IWVGA has been awarded \$3,345,000 to consolidate shallow well system(s) into a public water system.
- DWR has executed the grant agreement.
- Preliminary meeting with IWVWD on potential consolidation areas occurred on Feb 23.
- Preliminary potential consolidation area maps were provided to IWVWD.
- Potential systems/wells for consolidation are being further investigated.
- First Invoice and Progress Report will be due 5/30/24

2023 Drinking Water System Infrastructure Resilience and Sustainability Program

Staff submitted an application for federal funding on November 6, 2023 for approximately \$2.8 million to fund planning, design, environmental, and right-of-way tasks for the Imported Water Project. Funding awards are anticipated to be announced in Spring 2024.

AGENDA ITEM 12.b – GSP IMPLEMENTATION PROJECTS/MANAGEMENT ACTION UPDATES

Imported Water Project

- Imported Water Pipeline Design Services
 - Coordination Meetings:
 - Bi-weekly meetings with BLM
 - Updating SF-299 Application per BLM comments
 - Draft Plan of Design in compliance with the BLM’s Desert Renewable Energy Conservation Plan being revised
 - Ongoing coordination with State Water Resources Control Board Division of Drinking Water (DDW), Caltrans, United Pacific Rail Road (UPRR), and Southern California Edison (SCE)
 - SCE reviewing Customer/ Project Information Sheet (CPIS) application
 - GA Staff processing the California State Parks Right of Entry Application to prepare an Encroachment Permit and a check for the initial fee of \$500
 - Future fees include an analysis fee of \$10,000 and a final easement fee of approximately \$25,000
 - UPRR reviewing application for trenchless crossing at Neuralia Road and Cantil Road
 - Submitted response to comments from DDW on the Preliminary Design Report
 - Continuing soils borings in California City and Kern County right-of-way
 - Will focus on locations not adjacent to aquatic features until the California Department of Fish and Wildlife approves the Lake and Streambed Alteration Agreement

- Continuing utility research and trenchless crossing identification
 - Working on scour analysis for the Cantil and Redrock Canyon drainage washes, in non-BLM land near Neuralia Rd and Redrock Randsburg Road
- The General Manager approved a No-Cost Change Order on February 29, 2024 to adjust monies between project tasks
- Provided the Preliminary Permitting Requirements TM and now incorporating Staff comments
- Next Steps:
 - Start geotechnical borings in BLM land after cultural surveys are completed
 - Finalize the 30% Design Submittal
 - Provide the System Hydraulics and Transient Mitigation Analysis TM
 - Provide 60% Design Submittal by August
 - Next Milestones
 - Provide 90% Design Submittal by September 2024
 - Provide Final Design Submittal by April 2025
- Imported Water Pipeline Environmental Services
 - Coordination Meetings
 - Weekly meetings with BLM
 - Provided BLM with additional requested mitigation measures, the Biological Mitigation TM, and revegetation plan for geotechnical investigation
 - Received additional biological survey requirements from BLM
 - BLM approved a qualified biologist to perform the Botany Survey in March
 - Will provide candidates for a qualified Mojave Ground Squirrel and Desert Tortoise biologist for BLM review and approval
 - Submitted the USACE Permit Package
 - Completed cultural surveys on BLM land, to be followed by geotechnical surveys
 - Final Draft Cultural Report being prepared
 - BLM Reviewing NEPA Public Scoping Period Summary Report
 - Next Steps:
 - Begin geotechnical and biological monitoring on BLM lands
 - Finalize draft Environmental Impact Report, and BLM Environmental Assessment
 - Provide draft EA for Public Comment by mid-April
 - Next Milestones:
 - Finalize NEPA compliance for geotechnical borings and environmental surveys/ studies within BLM property
 - Conduct technical analyses/ Special Studies within BLM land
- Imported Water Pipeline Right-of-Way Services
 - Continue obtaining Rights of Entry from property owners along the pipeline alignment to allow performance of biological/technical studies and geotechnical borings
 - Next Milestone:
 - Provide a Right of Way Acquisition Plan by June 2024
- Submittals to DWR

- Submitted the final Preliminary Design Report on February 29, 2024, before the due date of March 31, 2024
- Submit Initial Study due September 1, 2024
- US Army Corps of Engineers Planning Assistance to States (PAS) Program
 - USACE Staff reviewing final proposed project list to start the development of an agreement with Army Corps
 - Next Steps:
 - Execute an agreement with Army Corps

Shallow Well Mitigation Program

- Updated Report Form and Fact Sheet
 - An updated Report Form and Facts Sheet incorporating comments from the PAC will be uploaded to the IWVGA website to provide additional information to well owners who may be interested in the Shallow Well Mitigation Program.
 - The Final Form and Facts Sheet were sent to the PAC Chair and PAC members for final review and no further comments were provided.
- Current Applications
 - Byerly Well
 - Received application from Mr. Byerly for the Primary Program.
 - Requesting financial assistance due to reduced water levels.
 - Staff provided draft staff report to applicant for review. The applicant indicated he had no comments on the staff report.
 - Halpin Well
 - Approved for \$6,000 for emergency assistance.
 - Received application from Mr. Halpin for the Primary Program
 - Received Well Driller's Report in December and working on Staff Report
 - Staff provided a draft staff report to applicant for review. The applicant indicated he had no comments on the staff report.

Impacted Shallow Wells	Evaluation Status
Stark Street	Application approved for partially funding. Completed
Heritage	Application Declined. Completed
Byerly	Staff recommendation in Board package
Halpin	Staff recommendation in Board package
Rademacher	Water Quality. Directed to the Shallow Well Mitigation Program and Capital Core. Kern County researching funding. Possible use of new DWR Consolidation Grant.

GSP Update

Revised Periodic Evaluation Schedule of Draft Releases

New Information Collected	March 2024
GSA Authorities and Enforcement Actions	April 2024
Monitoring Networks	April 2024
Outreach, Engagement, and Coordination	April 2024
Groundwater Conditions Relative to Sustainable Management Criteria	June 2024
Basin Setting Based on New Information/Changes in Water Use	July 2024
Status of Projects and Management Actions	August 2024
Summary of Proposed/Completed Revisions to Plan Elements	August 2024

Revised Submittal Process Schedule

Complete Draft Periodic Evaluation Released	September 2, 2024
Complete Draft Plan Amendment Released	September 30, 2024
Periodic Evaluation Comment Period	September 3, 2024 – October 7, 2024
Plan Amendment Comment Period	October 1, 2024 – November 4, 2024
Final Periodic Evaluation for Board Approval	November 13, 2024
Final Plan Amendment for Board Approval	January 8, 2025
Submittal to DWR	January 31, 2025

2023 Annual Report

WY 2023 Annual Report

- Comments on the draft WY 2023 Annual Report were due to the WRM by February 2, 2024.
 - Comments were provided by Mohave Pistachio, LLC and Searles Valley Minerals Inc.
- The draft WY 2023 Annual Report and comments are available on the IWVGA website.
- The final WY 2023 Annual Report will be provided at the IWVGA March Board Meeting and is due to DWR on April 1, 2024.

AGENDA ITEM 12c – MISCELLANEOUS ITEMS

Data Collection and Monitoring

- March 4-8, 2024
 - Spring 2024 bi-annual basin-wide groundwater level measurements and datalogger downloads.
 - Wellhead survey of a subset of monitoring wells.

GSP Model Configuration Management Plan (CMP)

- Technical Model Group (TMG)
 - TMG includes the Navy, TAC representatives, DRI, and Stetson
 - Dec 6, 2023, DRI/Stetson working call to review model updates
 - Dec 18, 2023, TMG meeting/call reviewed and finalized structural model components: faults, model boundaries, clay extents, discussed aquifer properties, evapotranspiration, and groundwater pumping
 - Jan 12, 2024, TMG meeting/call discussed mountain front recharge distribution and aquifer connectivity
 - Jan 30, 2024 TMG meeting/call reviewed modeling progress with recharge distribution, hydraulic conductivity zones, and calibration
 - Mar 5, 2024, TMG meeting/call to review LADWP Releases Data and modelling progress
 - Mar 18, 2024 TMG meeting/call to review Rose Valley hydrogeology and modeling progress
- Spring 2024 Schedule
 - Model Calibration, sensitivity analysis
 - Development of GSP model scenarios and water budgets
 - Biweekly TMG meetings to be scheduled to monitor modeling progress

Subflow from Rose Valley to IWV

- GA Reimbursement is being processed for first monitoring well (April)
- Executed Cooperative Agreement Modification for time extension requested through 2024 to complete permitting and drilling second monitoring well
- Ongoing work with BLM regarding Cultural Survey and Permitting for second monitoring well

ACTION(S) REQUIRED BY THE BOARD

There are no actions required by the Board.

The page intentionally blank

(DRAFT DATE MARCH 3, 2021)
(REDRAFT DATE FEBRUARY 27, 2024)

INDIAN WELLS VALLEY GROUNDWATER AUTHORITY
(IWVGA)

DE MINIMIS SHALLOW WATER SUPPLY WELL
NEGATIVELY IMPACTED BY CHRONIC
OVERDRAFTING OF GROUNDWATER
IN THE IWV BASIN
INTRODUCTION AND DISCLAIMER

The IWVGA approved the first phase of the “Shallow Well (Impacts) Mitigation Program”, Project No. 4 of the Authority’s Groundwater Sustainability Plan (GSP), January 2020. Phase one included development of the “Program” and initial “Outreach, Identification and Evaluation.”

This “Report Form” is part of the “Outreach, Identification and Evaluation” for potentially negatively impacted shallow wells, occurring “after February 1, 2020”, per the GSP. This Mitigation program is intended to apply only to a qualified well failure due to negative impacts related to the Basin overdraft including declining groundwater levels and specific water quality contaminant levels. A well is declared to be in a human health failure condition, if the well has water that reaches a Primary Standard level found in Title 22 of the California Code of Regulations. Funds for the Mitigation program are provided by a portion of the Basin Replenishment Fee approved by the GA Board in Ordinance 03-20 on August 21, 2020. This program will not provide funds or other support for the routine maintenance of a well, such as pump motor, drop pipe or drop wire replacement. All of the surface-related pumps, controllers, and storage tanks remain the sole responsibility of the owner. A prorated cost of IWVGA financial

contribution will be based on the calculated life of the well and other factors (present value evaluation).

DISCLAIMER: The Board has the sole discretion, based on the GSP, to fund the restoration of any well in the Indian Wells Valley Basin. The IWVGA may request additional information to supplement your completed Report Form, if it is not deemed complete. All information and data submitted to the IWVGA, related to this Report Form will remain confidential as permitted pursuant to the California Public Records Act, unless release is authorized, or the IWVGA addresses potential mitigation at a public meeting. Any shallow well mitigation plans addressed by the IWVGA will be held at a public meeting and will require public release of information and data related to your completed Report Form. The information requested below is consistent with the Notice of Groundwater Extraction Reporting for Pumping Verification – Questionnaire 1, which can be found under the forms and information section on the IWVGA website. In addition, the DWR Dry Well Reporting System Form was used (<https://mydrywell.water.ca.gov/report/reports/new>).

The page intentionally blank

Summary of IWV GA Shallow “de minimis” Groundwater Well Failure Due to Declining Water Levels and/or Declining Water Quality Occurring as a Result of Declining Water Levels

Subcommittee Recommendation Approved by Full Policy Advisory Committee September 28, 2023

Revised 1/9/24

1. **The definition of a “shallow well” and a “de minimis shallow well” are provided in this section, which would be incorporated into the IWVGA declining water level, failed well mitigation program.**
 - * The “de minimis shallow well” is a shallow well that is designed to produce a specific limited amount of groundwater. This well can have up to four separate de minimis connections, each using no more than 2 ac-ft per year. **It is this well type that is the subject of this document, as defined in California SGMA (Sustainable Groundwater Management Act). Over 90+ % of the IWV wells are de minimis.**
 - * A “shallow well” is defined as a well typically designed to produce a larger water quantity per year, as in a co-op or mutual water system. **The details of such a system often are more complicated technically and legally than a de minimis system and will be described separately from this document.** The mitigation of such a system at failure could involve a system redesign and reconstruction to enable combining with a neighboring system or joining a public water system.
 - * **No financial or legal discrimination is intended or implied in the separation into “de minimis shallow well” and “shallow well” types.**
2. **Typical de minimis shallow well casing design and depth.**
 - * A de minimis well is nearly always constructed with 6 inch *mild steel casing*, sometimes 8 inches, for shared wells. The well is usually 100 feet deeper than the *local* water table **based on the American Water Works Association (AWWA) A-100 guidelines. It is advisable in area of seriously declining water levels to drill deeper, perhaps providing 140’ or even more of standing water in a new well.**
3. **Typical screen design for a de minimis shallow well.**
 - * A de minimis well is typically provided with 40 feet of perforated section (the screen) at the bottom of the well casing. **Wells are often found in this Valley with a longer screen section but the additional screen usually served no good purpose. In fact, it directly reduces the life of the well (see Sec.5).**
4. **Typical pump and motor design for a de minimis shallow well.**
 - * A 1 or 1½ horsepower well pump and motor are sufficient for de minimis purpose with present day water depths. Somewhat larger pumps and motor are required for shared wells, up to 5 horsepower.
5. **De minimis shallow well failure. The IWV Groundwater Authority (GA) has authorized monetary compensation for failure of shallow de minimis wells which are directly related to declining groundwater levels or associated TDS (total dissolved solids) or specific EPA contaminant level increases in the pumped water (see further down in this section). The GA compensation might involve redrilling and sleeving the existing well or drilling a new deeper well.**
 - * **Assumed failure.** The groundwater level related well failures are commonly thought to be a *direct* result of the well groundwater level declining and *drying out the well*. **This virtually never happens in a water producing well as other failures will precede this point.**
 - * **The processes of mechanical failure** take a huge negative step when the pump is lowered (to stay covered as the water table declines) to the point that the *pump intake is within the casing perforations*. Depending upon the composition of the fines of the alluvial material outside of the casing (opposite the pump intake) the pump intake suction will draw in more or less sand and similar abrasive materials.

This sand can cause erosion and clogging of the perforations and pump intake screen and the pump itself and can cause pump failure in a relatively short time. ***This is a very serious well issue and often is the cause of immediate well failure.***

- * **The next potential corrosion failure step.** If the well water level continues to drop, it will eventually reach the top of the screen. At this point, exposure of the screen to the air will result in a *substantially accelerated* corrosion (rusting) of the perforated section of the well. **This step can result in casing failure.**
 - * **The corrosion failure from increasing TDS (total dissolved solids)** are more subtle and often involve corrosion pitting and even casing failure. Most wells are completed with a mild steel casing. **The failure of such a well commonly progresses from corrosion which is eating away the casing wall, to the point of casing collapse.** In this Valley, the causes are primarily due to i) high chloride and/or sulfate ion concentrations present in the groundwater at some locations or ii) the high iron/manganese in some groundwater that encourages growth of an iron bacteria that creates thick coatings of ferrous hydroxide. The coating is not uniform in thickness and the holes of the perforation section and the casing itself are weakened.
 - * **Well water chemistry and human health.** The TDS of the water pumped in most wells in the IWV is slowly increasing as the water table declines. **However, most IWV wells will ultimately fail from water level declines, not from increasing in TDS. Even if the increase in TDS does not cause casing corrosion failure, it may ultimately become a health issue.** Well owners who have a well which is producing high TDS water, should be vigilant in getting regular water chemistry analyses, especially if the water is high in iron, manganese or arsenic.
 - * **A well is declared in a human health failure condition, if the well water reaches the Primary Standards level of an Title 22 of the California Code of Regulations. If the well at a previous time was producing water at a lower contaminant level, it may be approved for GA mitigation. For more guidance see the Title 22 of the California Code of Regulations.** (The IWV Water District may provide sample containers and coordination of samples with a licensed laboratory they are using.)
6. **Well maintenance.** Much concern has been made of the maintenance that a well received. **It is very important for the well owner to have knowledge and understanding of his well, and its history.**
- * **It is the sole responsibility of the well owner to maintain the equipment in his well.** For a shallow de minimis well the *only* maintenance usually made (or necessary) is to replace the pump and motor when a failure occurs in those components and to add a length of drop pipe and wire to the motor when it is replaced to keep up with declining water levels,
7. **Apportioning the cost of well repair.** Not all of the cost of well repair would be borne by the GA in their mitigation program. A prorated cost based on the calculated life of the well and other factors discussed above would be used to determine the GA financial contribution. **This is a complicated calculation and is often imperfect.**
- * **The physical life of a well** as actually observed can vary by a factor of nearly *ten* with the complex IWV Basin groundwater chemistries. If a well owner is willing to do a simple *video examination* of the subject failed well, much conjecture (and argument) can be eliminated. **Ultimately, the well owner still has the primary responsibility for the well.**
8. **A Report Form** that uses the factors described in this Committee Report would provide an accurate assessment of a failed well and should be a topic for the 2025 revisions to the GSP.

The page intentionally blank

REPORT FORM

How to Submit a Mitigation Request to the IWV GA for a Shallow “de minimis” Groundwater Well Failure Due to Declining Water Levels and/or Declining Water Quality Occurring as a Result of Declining Water Levels

Subcommittee Recommendation Approved by Full Policy Advisory Committee September 28, 2023

(Subcommittee Members: Judie Decker, Lyle Fisher, West Katzenstein and Don Decker)

1. The Mitigation Request starting point is the submission of a recent report by a licensed well driller or well maintenance company for the subject failed well. This report should contain:

- * Date of Report and identity of the preparer including license number
- * Measured depth of the groundwater in the subject well
- * Measured depth of the well pump intake
- * Measured depth of the well
- * Summary of the well failure cause(s)

2. Also submit, *as available*, all earlier well reports provided to the owner at the time of completion of the well and subsequent maintenance including replacement(s) of the well pump and/or motor and drop pipe and wiring as was necessary to keep up with a declining groundwater situation. The completion report will contain the information requested in no. 1 at the time of well drilling and further details of the well. It would also be potentially useful to submit well water Chemistry Report(s) from a licensed firm. Here is a list of suggested items:

- * Length of the perforated section
- * Depth of the completed well
- * Depth to groundwater
- * Casing type and diameter
- * Size of the well pump and motor
- * General Mineral well water chemistry report
- * Report on the video examination of the failed well, including frames of damaged areas

3. Submit known history of the well, including estimates of rate of water pumped and total water pumped. In addition, include history concerning groundwater level declines.

- * In this well or nearby wells

4. If the well has failed due to water quality issues, water chemistry reports should be submitted. Especially important are reports that *span the period of time* the well has been pumped.

- * General Mineral well water chemistry reports from a licensed firm that document the declining water quality

The page intentionally blank

BUDGET TO ACTUAL REPORT- 2023 with February Accruals

ACTUALS BY REVENUE ALLOCATION														
			Restricted	Restricted	Restricted	Restricted	Restricted	Restricted	(A-B)		(B/A)			
			Extraction	Augmentation	Shallow Well Mitigation	Prop. 1; Prop.68 SDAC/ Misc Grant	SGMA IP Urban Comm.	Navy/COSO Fund	\$ Estimated	\$ REMAINING	% COMPLETED			
	PROPOSED BUDGET ORIGINAL	AMENDMENT	TOTAL ADJUSTED BUDGET											
1	REVENUE											1		
2	Extraction Fee	1,319,924	(55,964)	1,263,960	1,606,761	-	-	-	-	-	1,606,761	(342,801)	127%	2
3	Transfer In/Loan from Augmentation Fund	367,814	64,247	432,061	-	-	-	-	-	-	-	432,061	0%	3
4	Transfer In/Loan from Grant Funds-Prop 1/Prop 68	204,636	-	204,636	-	-	-	-	-	-	-	204,636	0%	4
5	Augmentation Fee	3,912,060	(790,789)	3,121,271	-	2,990,997	-	-	-	-	2,990,997	130,274	96%	5
6	Transfer In/Loan Repayment from Extraction Fund	-	-	-	-	-	-	-	-	-	-	-	0%	6
7	Shallow Well Mitigation Fee	125,776	7,619	133,395	-	-	101,266	-	-	-	101,266	32,129	76%	7
8	Department of Water Resources (DWR) Grants-Prop 1/68	204,636	-	204,636	-	-	-	132,419	-	-	132,419	72,217	65%	8
9	Department of Water Resources (DWR) Grants -IP Grant	2,000,000	1,663,960	3,663,960	-	-	-	-	435,887	-	435,887	3,228,073	12%	9
10	Urban Community Drought Relief Grant Program	-	20,000	20,000	-	-	-	-	-	-	-	20,000	0%	10
11	Navy/COSO Royalty Fund	15,000	192,879	207,879	-	-	-	-	-	-	-	207,879	0%	11
12	Miscellaneous Revenue	-	-	-	-	-	-	11,429	-	-	11,429	(11,429)	0%	12
13													0%	13
14	TOTAL REVENUES	8,149,846	1,101,952	9,251,798	1,606,761	2,990,997	101,266	143,848	435,887	-	5,278,759	3,973,039	57%	14
15	EXPENSES											15		
16	Administration											16		
17	Administration (RGS)	333,000	(18,000)	315,000	135,186	135,186	-	-	-	-	270,373	44,627	86%	17
18	Office Rent (City of Ridgecrest)	3,600	-	3,600	1,500	1,500	-	-	-	-	3,000	600	83%	18
19	Office Supplies	1,000	-	1,000	35	35	-	-	-	-	69	931	7%	19
20	Postage and Delivery	360	-	360	-	-	-	-	-	-	-	360	0%	20
21	External Audit	12,000	(4,000)	8,000	4,000	4,000	-	-	-	-	8,000	-	100%	21
22	Council Chambers/IT Services (City of Ridgecrest)	8,500	-	8,500	-	-	-	-	-	-	-	8,500	0%	22
23	General Counsel (Aleshire & Wynder/City of Ridgecrest)	200,000	87,300	287,300	18,085	-	-	-	-	-	18,085	269,215	6%	23
24	Insurance Premium	14,870	(53)	14,817	14,817	-	-	-	-	-	14,817	-	100%	24
25	Legal Notices (Daily Independent)	2,000	-	2,000	-	-	-	-	-	-	-	2,000	0%	25
26	Memberships (Cal. Assoc.Mutual Water Co)	100	-	100	100	-	-	-	-	-	100	-	100%	26
27	Website	300	12	312	312	-	-	-	-	-	312	-	100%	27
28	Printing and Reproduction	-	-	-	-	-	-	-	-	-	-	-	0%	28
29	Bank Service Charges	24	-	24	-	-	-	-	-	-	-	24	0%	29
30														30
31	Non-Departmental											31		
32	Other Legal Services (RWG Law)	400,000	5,000	405,000	-	370,009	-	-	-	-	370,009	34,991	91%	32
33	Lobbying Services (Capitol Core)	174,000	22,000	196,000	-	196,119	-	-	-	-	196,119	(119)	100%	33
34	Other Professional Services (Garrison Brothers)	-	146,669	146,669	-	-	-	-	-	146,669	146,669	(0)	100%	34
35	Shallow Well Mitigation Emergency Assistance Program	50,000	(11,179)	38,821	-	-	4,419	-	-	-	4,419	34,402	11%	35
36	Repayment of Kern County Advance	-	-	-	-	-	-	-	-	-	-	-	0%	36
37	Repayment of City of Ridgecrest In-Kind Services	500,000	-	500,000	390,000	110,000	-	-	-	-	500,000	-	100%	37
38	Transfer Out/ Loan Repayment to Augmentation Fund	-	-	-	-	-	-	-	-	-	-	-	0%	38
39	Transfer Out/Loan to Extraction Fund	572,450	64,247	636,697	-	-	-	-	-	-	-	636,697	0%	39

BUDGET TO ACTUAL REPORT- 2023 with February Accruals

ACTUALS BY REVENUE ALLOCATION												
	PROPOSED BUDGET AMENDMENT	TOTAL ADJUSTED BUDGET	Restricted Extraction	Restricted Augmentation	Restricted Shallow Well Mitigation	Restricted Prop. 1; Prop.68 SDAC/ Misc Grant	Restricted SGMA IP Urban Comm.	Restricted Navy/COSO Fund	\$ Estimated	(A-B) \$ REMAINING	(B/A) % COMPLETED	
40												40
41	Community Engagement											41
42	Design Services	(20,000)	5,000	-	-	-	-	-	-	5,000	0%	42
43	Printing and Reproduction	(5,000)	5,000	-	-	-	-	-	-	5,000	0%	43
44	Website Services	(20,000)	5,000	3,621	-	-	-	-	3,621	1,380	72%	44
45												45
46	Basin Management Administration											46
47	Production Reporting, Transient Pool, and Fee Support (Stetson)	40,000	45,000	38,663	-	-	-	-	38,663	6,337	86%	47
48	Meetings and Prep (Stetson)	25,000	165,000	145,013	-	-	-	-	145,013	19,987	88%	48
49	Budget Support (Stetson)	(1,500)	6,000	4,524	-	-	-	-	4,524	1,477	75%	49
50	Stakeholder Coordination (Stetson)	(9,000)	1,000	-	-	-	-	-	-	1,000	0%	50
51	Litigation Support (Stetson)	10,000	50,000	48,414	-	-	-	-	48,414	1,586	97%	51
52												52
53	Basin Management											53
54	General Engineering (Stetson)	(30,000)	20,000	16,360	-	-	-	-	16,360	3,640	82%	54
55	TSS: El Paso Well Drilling Support (Stetson)	-	-	-	-	-	-	-	-	-	0%	55
56	TSS: General Coordination/Application Support (Stetson)	(12,000)	3,000	1,901	-	-	-	-	1,901	1,099	63%	56
57	Coordination with DWR on GSP Review (Stetson)	-	-	-	-	-	-	-	-	-	0%	57
58	GSP 5-Year Update (Stetson)	110,000	160,000	116,800	-	-	-	-	116,800	43,201	73%	58
59	Annual Report Preparation (Stetson)	5,000	55,000	43,324	-	-	-	-	43,324	11,676	79%	59
60	Data Management System Support (Stetson)	(5,000)	25,000	24,361	-	-	-	-	24,361	639	97%	60
61	Allocation Plan: Allocation Process & Transient Pool Support (Stetson)	-	-	-	-	-	-	-	-	-	0%	61
62	Allocation Plan and Rules & Regs on Pumping/Restrictions (Stetson)	(3,000)	9,000	7,137	-	-	-	-	7,137	1,863	79%	62
63	Allocation Plan: Fallowing & Transient Pool Transfer Program (Stetson)	-	-	-	-	-	-	-	-	-	0%	63
64	Conservation Efforts (Stetson)	(10,000)	-	-	-	-	-	-	-	-	0%	64
65	General Project Management (Stetson)	30	30,030	28,549	-	-	-	-	28,549	1,481	95%	65
66	Model Transfer and Upgrade (Stetson)	29,000	229,000	165,133	-	-	-	-	165,133	63,867	72%	66
67	Navy/Coso Royalty Fund: Develop Projects & Secure Funding (Stetson)	3,000	28,000	23,414	-	-	-	-	23,414	4,586	84%	67
68	Navy/Coso Royalty Fund: Rose Valley MW Permitting, Bid, Drilling (Stetson)	31,210	46,210	-	-	-	-	45,077	45,077	1,133	98%	68
69	Navy/Coso Royalty Fund: Cooperative Agreement	15,000	15,000	-	-	-	-	15,371	15,371	(371)	102%	69
70	Data Collection, Monitoring, and Data Gaps (Stetson)	20,000	165,000	129,541	-	-	-	-	129,541	35,459	79%	70
71	Imported Water: Negotiations and Coordination(Stetson)	-	20,000	-	20,187	-	-	-	20,187	(187)	101%	71
72	Imported Water: Engineering and Analysis(Stetson)	-	-	-	-	-	-	-	-	-	0%	72
73	Recycled Water (Stetson)	(90,000)	60,000	-	56,768	-	-	-	56,768	3,232	95%	73
74	LADWP Release Coordination and Meetings	45,000	45,000	41,104	-	-	-	-	41,104	3,896	91%	74
75	CA State Lands Commission	140	140	140	-	-	-	-	140	-	100%	75
76												76

BUDGET TO ACTUAL REPORT- 2023 with February Accruals

ACTUALS BY REVENUE ALLOCATION													
	PROPOSED BUDGET	TOTAL ADJUSTED BUDGET	Restricted Extraction	Restricted Augmentation	Restricted Shallow Well Mitigation	Restricted Prop. 1; Prop.68 SDAC/ Misc Grant	Restricted SGMA IP Urban Comm.	Restricted Navy/COSO Fund	\$ Estimated	(A-B) \$ REMAINING	(B/A) % COMPLETED		
	ORIGINAL	AMENDMENT											
77	EXPENSES (Cont'd)												77
78	Basin Management (cont'd)												78
79													79
80													80
81													81
82													82
83													83
84													84
85													85
86													86
87	Grant Management												87
88													88
89													89
90													90
91													91
92	IP Grant Management												92
93													93
94													94
95													95
96													96
97													97
98													98
99													99
100													100
101													101
102													102
103													103
104													104
105													105
106	Urban Community Drought Relief Grant Program												106
107													107
108													108
109													109
110	TOTAL EXPENSES												110
111													111
112	Surplus (Deficit)												112

Billing and receipt of reimbursement grant program revenue may cross over fiscal years with revenue received for prior year programs. Separate reconciliation will be completed for grant programs.

MONTH TO DATE REVENUES & EXPENDITURES EXCLUDING TRANSFERS

	Revenue	Transfer In*	Transfer Out*	Expenses	Surplus (Deficit)
Extraction Fund	1,606,761	-	-	1,480,205	126,556
Augmentation Fund	2,990,997	-	-	893,804	2,097,193
Shallow Well Mitigation Fund	101,266	-	-	47,689	53,577
Department of Water Resources (DWR) Grants-Prop 1/68/MISC	143,848	-	-	-	143,848
Department of Water Resources (DWR) Grants -IP Grant	435,887	-	-	3,130,059	(2,694,171)
Navy/COSO Royalty Fund	-	-	-	207,117	(207,117)
Total	<u>5,278,759</u>	<u>-</u>	<u>-</u>	<u>5,758,874</u>	<u>(480,114)</u>

** The Extraction Fund Budget will be balanced through a loan from the Augmentation Fund.*

OUTSTANDING OBLIGATIONS

	City of Ridgecrest	Augmentation Fund	Total
In-Kind Services ¹			
Attorney Svcs./IT/Chambers -FY24 - Budgeted	317,500	-	317,500
Attorney Svcs./IT/Chambers -FY23 -Actual	255,605	-	255,605
Attorney Svcs./IT/Chambers -FY22	241,204	-	241,204
Attorney Svcs./IT/Chambers -FY 21	325,235	-	325,235
Attorney Svcs./IT/Chambers -FY's16-20	366,982	-	366,982
Repayment in FY2023 for Prior Years	(500,000)	-	(500,000)
Repayment in FY2023 for Current Year-Budgeted Pmt	(208,500)	-	(208,500)
Inter-Fund Loans			
2024 Loan to Extraction Fund-Estimated ²	-	701,000	701,000
2023 Loan to Extraction Fund-Estimated ²	-	200,000	200,000
Repayment of Adv. Of Funds ³	-	642,200	642,200
Advance of Funds			
	-	-	-
Financing			
	-	-	-
Postponed Invoice Payments			
	-	-	-
Total	798,026	1,543,200	2,341,227

¹ City of Ridgecrest In-Kind Services includes services associated with Extraction and Augmentation expenses.

² Estimated; FY2024 is included in proposed budget

³ IWVWD used restricted Augmentation Revenue to repay the Advance Agreement of \$500,000
Repayment of the IWVWD Advance requires a transfer from the Extraction Fund to the Augmentation Fund.

³ Kern Cnty Repymnt was \$500k but it is estimated only \$142,200 will be loaned from the Augmentation Fund

ADOPTED 2024 OBLIGATION REPAYMENTS

	City of Ridgecrest	Augmentation Fund	Total
In-Kind Services			
Attorney Services/IT/Council Chambers	500,000	-	500,000
Advance Agreements			
Advance of Funds	-	-	-
Financing			
Water Purchase related Financing	-	-	-
	-	-	-

Upon repayment of Obligations, an inter-fund loan will be created between the Extraction Fund and Augmentation Fund for amount not funded by the Extraction Fund.

CASH BALANCE

February 2024 Activity

Cash Receipts (Receipts over \$50,000 and all grants are detailed)	
IWVWD Augmentation/Extraction/SWM- January	\$ -
IWVWD Augmentation/Extraction/SWM-February	-
Grant Revenue	-
All Other Cash Receipts -FY 2023	8.29
All Other Cash Receipts -FY 2024	64,100.28
Total Cash Receipts	<u>\$ 64,108.57</u>

Cash Disbursements (Obligation payments are detailed)	
Warrant-January for 2023 Services	\$ 3,863.60
Warrant-January for 2024 Services	\$ 4,247.37
Total Cash Disbursements	<u>\$ 8,110.97</u>

Cash Balance

Prior Month to Current Month Ending Balance Reconciliation

January Cash Balance By Investment	
Kern County Treasurer	\$ 4,466,573.70
AltaOne Credit Union	515,477.11
Total End of Month Cash Balance	<u>\$ 4,982,050.81</u>

February Activity	
Cash Receipts	\$ 64,108.57
Cash Disbursements	(8,110.97)
Kern County -Adj	-
Total End of Month Activity	<u>\$ 55,997.60</u>

January Ending Cash Balance	\$ 5,038,048.41
Less: Outstanding Warrants -January for 2023 Services	(197,199.60)
Less: Outstanding Warrants -January for 2024 Services	(256,032.54)
Less: Outstanding Warrants -February for 2024 Services	(254,373.16)
Less: Outstanding Warrants -February for 2023 Services	(25,317.35)

Total Available Cash By Activity	<u>\$ 4,305,125.76</u>
----------------------------------	------------------------

February Cash Balance by Investment	
Kern County Treasurer	\$ 5,038,048.41
AltaOne - In Transit to Kern County	-
Total End of Month Balance	\$ 5,038,048.41
Less: Outstanding Warrants	(732,922.65)
Total Available Cash by Investment	<u>\$ 4,305,125.76</u>

Cash Receipts are deposited in AltaOne Credit Union and sent electronically to Kern County Treasurer. Cash in Transit at month end will be reflected in the Kern County Treasurer balance. Warrants are approved by IWVGA Board and administratively processed by IWVGA staff. Warrants are executed by Kern County staff. Outstanding Warrants are vendor invoices received and not yet paid. Outstanding Obligations are detailed in a separate attached report. Currently invoiced reimbursements to DWR total \$2.57 million.

The page intentionally blank



To: Carol Thomas-Keefer, General Manager – Indian Wells Valley Groundwater Authority

From: Michael W. McKinney, Capitol Core Group

cc: Keith Lemieux, Counsel IWVGA
Phillip Hall, Counsel, IWVGA
Steve Johnson, Stetson Engineers
Jeff Simonetti, Capitol Core Group
Todd Tatum, Capitol Core Group

Date: March 13, 2024

Subject: February 2024 Project Update

The following will provide activities and updates for February 2024.

Task 1: Imported Water Supplies

For Task 1, Capitol Core staff continued to work with two potential water suppliers on providing imported water supplies. In addition, staff assisted the engineering teams at Provost & Pritchard and Stetson on pipeline-related items. In March, we plan to continue to engage with the Antelope Valley – East Kern Water Agency to coordinate planning activities for the interconnection pipeline.

Task 2: Interconnection Pipeline Project

Note for Items Below: The two items below discuss state and federal budget requests to secure the funding needed for the final planning for the imported water pipeline. Capitol Core anticipates that these monies, should our efforts be successful, will complement each other and help provide the final monies necessary to complete the planning and monitoring tasks required for the project.

UPDATE: *State Budget Act for Fiscal Year 2024-2025*

Capitol Core continues to look for opportunities in the State budget to secure further planning grants for the interconnection project to finalize its engineering and related studies. As discussed below, the Legislative Analyst's Office increased the projected State budget deficit on February 28th from \$58 billion to \$73 billion. While this increased budget deficit may hamper the consideration of supplemental budget requests, we are working through our local delegation to determine opportunities where we may secure these funds.

Task 3: Other Projects Supporting the GSP

UPDATE: *Energy & Water Development Act for Fiscal Year 2025*

In January, Capitol Core made a request for Representative Jay Obernolte (R-CA 23rd) to consider submitting a Community Project Funding Request (“earmark”) in the amount of \$1.6 million under Section 22 (“Planning Assistance”) of the *Water Resources Development Act of 1974*. The earmark would be included in the annual *Energy & Water Development Act* as a Fiscal Year 2025 request. If granted, the earmark would fund U.S. Army Corps of Engineers (USACE) assistance for watershed management planning (“GSP Updates”), validation of specific studies, including basin percolation and GSP findings validation, and water resource planning. The request replaces the Planning Assistance to States application for USACE assistance for interconnection pipeline planning activities that were not permitted due to SGMA-IP funding timelines required by DWR.

FY2025 requests are likely due to Members of Congress in March. FY2025 Appropriations are expected to be delayed as a result of ongoing Congressional activity for FY2024. Congressional leaders have given no timeline for when they will open FY 2025 appropriations requests for consideration. **Regarding the FY 2024 deadlines** – As of the time we wrote this memo, the Congress agreed to a short-term Continuing Resolution that funds the government until either **March 8th** or **March 22nd** depending on the departments and associated appropriations bills. The Congress must agree to the following appropriations bills by the deadlines below to avert a government shutdown:

March 8th Deadline Bills:

- Agriculture-FDA
- Commerce, Justice and Science
- Energy and Water Development
- Interior
- Military Construction-Veterans Affairs
- Transportation-Housing and Urban Development

March 22nd Deadline Bills:

- Defense
- Financial Services and General Government
- Homeland Security
- Labor-Health and Human Services
- Legislative Branch
- State and Foreign Operations

Federal Legislative Updates

UPDATED REPORT/Priority Bill: *Low Income Household Water Assistance Program (LIHWAP) -Senator Padilla*

In January, we flagged a bill from Senator Padilla's office entitled the Low-Income Household Water Assistance Program. The bill would create a permanent, nationwide water assistance program that would help low-income households afford their water bills. The program would extend a COVID-19 era program that provided assistance to families across the country struggling to pay their water bills. The program in California has funding through March 2024. However, without further appropriation, the program will end. Senator Padilla introduced the bill to extend this program. You can view the press release with links to the bill text and summaries [here](#).

State Legislative Updates

UPDATED REPORT/Priority Bill: *State Budget Act for Fiscal Year 2024-2025*

Since our February monthly memo, the California Legislative Analyst's Office (LAO) updated the budget deficit projections. While the Newsom Administration initially anticipated a \$58 billion budget deficit, the LAO's February 20th update now anticipates a \$73 billion deficit, one of the highest ever in the State. You can view the updated projections [here](#). The LAO report recommends that the Legislature consider one-time spending reductions as the first option to address the budget situation the state faces. If the Legislature considers this option, it could hamper our efforts to secure funding for the increased planning costs necessary to complete the interconnection project tasks.

The Assembly Budget Committee No. 4 on Climate Crisis, Resources, Energy and Transportation also plans to hold an informational hearing on March 6th to discuss how the budget challenges will affect the departments related to water and natural resources. You can view the agenda [here](#). Please see Pages 13-14 for a discussion on the "solutions" (the term that the Budget Committee uses for budget cuts) to the Drought and Water Resilience portions of the budget. The committee is proposing a reduction of \$810.3 million in FY 24-25 spending on water and drought programs.

Bill Tracking Report:

February 16th was the deadline for legislators to submit bills. Capitol Core listed a series of bills in our tracking report last month that we are monitoring for the IWVGA. We have initial text for bills that we are monitoring with the exception of the final "spot bills" that were submitted. "Spot bills" are essentially placeholder bills that provide a general area of law where legislators may want to amend but provide specifics on code at a later date. The specifics of "spot bills" were due to Legislative Counsel at the end of February. Capitol Core is still reviewing the final spot bill submissions and will provide updates on these bills and hearing dates for priority bills in March.

The page intentionally blank

INDIAN WELLS VALLEY GROUNDWATER AUTHORITY
Legislative Tracking Report

118th Congressional Session
2023-2024 California State Session

Updated to 22 March 2024



CAPITOL **CORE** GROUP



PRIORITY BILLS

Legislation of significant impact on operations or interests. Legislation where a public position may be taken with the legislative body. Updates are provided to staff as they occur, potentially requiring action, and reported herein.

Positions Taken:



Indicating a public position of support for the legislation.



Indicating a public position of opposition for the legislation



Indicating a neutral position on the legislation. Public position or no-public position taken.



Indicating a position of “Amend” and presenting amendments that would change the public position to support.



Indicating a position of oppose unless amended.

Federal – the 118th Congressional Session



UPDATED INFORMATION: HR 7065 (Napolitano, D-CA, 31st): Priority for Water Supply and Conservation Act of 2024



Introduced 01/22/2024.

This amendment to the Water Resources Development Act of 1974 adds water supply and conservation to the list of “primary mission” projects of the U.S. Army Corps of Engineers Civil Engineering Programs.

House Committee on Transportation & Infrastructure

[Current Text](#)

NEW ACTION: S. 3830 (Padilla, D-CA) – The Low-Income Household Water Assistance Program Act of 2024



A bill to establish a permanent Low-Income Household Water Assistance Program. Similar to LIHEAP.

As Introduced 02/28/2024

Senate Committee on Health, Education, Labor and Pensions

[Current Text](#)

NEW: WATER RESOURCES DEVELOPMENT ACT OF 2024

House Bill (Graves, R-MO 6th):

Status of IWVGA Authorization Request: Member Submitted the IWVGA request: House Committee on Transportation and Infrastructure

Status of Bill: Information Gathering; Oversight Hearings Pending; No bill on file.

Senate Bill (Carper, D-DE):

Status of IWVGA Authorization Request: Member Submitted the IWVGA request: Senate Committee on Environment and Public Works

Status of Bill: Oversight Hearings Held; bill in drafting stage; No bill on file.

State of California – 2023-2024 California Session



AB 560 (Bennett, D-38th) – Groundwater Adjudications



Requires parties in adjudication to seek a nonbinding advisory opinion from the SWRCB in conjunction with DWR on the impacts of a proposed settlement agreement to small farmers and the GSP.

As Amended 06/26/2023.

Senate Committee on Appropriations – Held on Suspense File (two-year bill)

[Current Text](#)

AB 1827 (Papin, D-21st): Local Government Finance: Water: Higher Consumptive Water Parcels

As Introduced 01/12/2024

This bill would provide that the fees or charges for property-related water service imposed or increased, as specified, may include the incrementally higher costs of water service due to specified factors, including the higher water usage demand of parcels. The bill would provide that the costs associated with higher water usage demands, the maximum potential water use, or a projected peak water usage demand may be allocated using any method that reasonably assesses the water service provider's cost of serving those parcels that are increasing potential water usage demand, maximum potential water use, or project peak water use demand. The bill would declare that these provisions are declaratory of existing law. Moved to Priority List at request of counsel.

Assembly Committee on Local Government (pending hearing schedule)

[Current Text](#)

AB 2079 (Bennett, D-38th): Sustainable Groundwater Management Act: Groundwater Basins



“Spot” bill making non-substantive changes to SGMA. Awaiting Amendments.

As Introduced 02/06/2024

Assembly Desk (awaiting referral)

[Current Text](#)

AB 2614 (Ramos, D-45th): Water



As Introduced 02/14/2024.

“Spot” bill makes non-substantive changes to reasonable and beneficial use conservation standards. Awaiting Amendments

Assembly Desk (awaiting referral)

[Current Text](#)

AB 2799 (Fong, R-32nd): Sustainable Groundwater Management Act: Groundwater Sustainability Agencies.



As Introduced 02/16/2024

“Spot Bill” making non-substantive changes to SGMA regarding GSAs. Awaiting Amendments. Expected amendments to provide for a “fee credit” for agriculture and district groundwater replenishment.

Assembly Desk (awaiting referral)

[Current Text](#)

AMENDED IN: ACA 2 (Alanis, R-22nd): Water Resiliency Act of 2024

As Amended 03/06/2024

This measure would require the Treasurer to annually transfer an amount equal to 1.5% of all state revenues from the General Fund to the California Water Resiliency Trust Fund, which the measure would create. The measure would continuously appropriate moneys in the fund to the California Water Commission for its actual costs of implementing these provisions and for specified water infrastructure projects.

Hearing Cancelled at the request of the Author: Assembly Committee on Water, Parks and Wildlife

NEW ACTION: SB 1156 (Hurtado, D-16th): Groundwater Sustainability Agencies: Financial Disclosure Reports



As Introduced 02/15/2024

The legislation requires a groundwater sustainability agency's board and executive staff members to provide annual financial disclosure reports (Form 700) and the FPPC to develop implementing regulations. It will also create additional regulatory requirements for staff.

HEARING SCHEDULED – APRIL 9, 2024: Senate Committee on Natural Resources and Water
Senate Committee on Elections and Constitutional Amendments (sequentially referred)
[Current Text](#)

NEW ACTION: SB 1210 (Skinner, D-9th): Water Connection Charges



As Amended 03/18/2024

This bill limits the ability of the Water District, the City, and the Authority to charge a connection charge that exceeds one percent of the reported building permit value for new residential construction. The amendments included municipal utilities. Initial proposed amendments from the Authority were rejected. Capitol Core is working with the Author's office on new amendments.

Hearing Set: April 2, 2024 – Senate Committee on Energy, Utilities, and Communications
[Current Text](#)



WATCH BILL LIST

Legislation of interest to the Authority. The Authority may adopt a “neutral” position, or no public position is taken. Updates are provided monthly unless the amendment warrants immediate notification to staff.

Federal – the 118th Congressional Session



HR 186 (McClintock, R-CA, 5th) – The Water Supply Permitting Coordination Act of 2023

Authorizes the Secretary of the Interior to coordinate Federal and State permitting processes related to the construction of new surface water storage projects on lands under the jurisdiction of the Secretary of the Interior and the Secretary of Agriculture and to designate the Bureau of Reclamation as the lead agency for permit processing.

As Introduced
House Committee on Natural Resources

HR 215 (Valadao, R-CA 22nd) – Water for California Act of 2023

Authorizes several federal (CVP) and State Water Project authorizations. Designates the USBR as the lead agency for federal permitting requirements. To provide long-term water supply and regulatory reliability to drought-stricken California. The introduced version was incorporated into HR 1 and HR 2811.

CBO Budget Estimate Provided to Rules Committee 02/22/2024. Scored at a financial impact of \$264 million over the life of the bill 2024-2033.

As Amended in the Nature of a Substitute
Ordered Reported (passed) House Committee on Natural Resources,
To the Committee on Rules

HR 1152 (Rouzer, R-NC 7th) – Water Quality Certification and Energy Project Improvement Act

This bill revises the water quality certification process under Section 401 of the Clean Water Act (CWA) for any activity that requires a federal license or permit and may result in a discharge of pollutants into the United States' waters. These activities include hydropower, natural gas pipelines, and mining projects.

Under the existing Section 401, an applicant for a federal license or permit to conduct such activities must provide the federal licensing or permitting agency with a certification. The certification must attest that the discharge will comply with enumerated sections of the CWA (i.e., Sections 301, 302, 303, 306, and 307) and with any other appropriate requirement of state law outlined in the certification. The certifying authority—usually the state where the discharge

originates, but sometimes an Indian tribe or the Environmental Protection Agency (EPA)—may grant with conditions, deny, or waive certification of a proposed federal license or permit. This bill limits the scope of the certification process by eliminating the requirement that the discharge comply with appropriate state law outlined in the certification. It also requires decisions to grant or deny a request for certification based only on the enumerated sections of the CWA and provisions of state law that implement water quality criteria under Section 303. In addition, it also limits the certification process to activities that may directly result in a discharge into waters of the United States.

In addition, the bill requires certifying authorities to identify all materials or information necessary to grant or deny the request within 90 days of receiving a request for certification. They must also publish requirements for their water quality certifications.

HR 1152: Ordered Reported House Committee on Transportation and Infrastructure
Incorporated in HR 1
Incorporated into HR 2811

HR 1430 (Valadao, R-CA 22nd) – NEPA Permit Streamlining Act of 2023

The bill directs the Secretary of the Interior and the Secretary of Agriculture to use certain previously completed environmental assessments and environmental impact statements to satisfy NEPA's review requirements.

As Introduced
Incorporated into HR 1
House Committee on Natural Resources

HR 1556 (Miller, R-IL, 15th) and S. 1022 (Braun, R-IN) – The Define the WOTUS Act of 2023

Provides a statutory definition of Waters of the United States.

HR 1556:
House Floor – To Union Calendar
House Subcommittee on Water Resources and Environment
S. 1022:
Senate Committee on Environment and Public Works

HR 1740 (Bost, R-IL): WIFIA – State and Local Performance Requirements

WIFIA loan holders must provide a performance or payment obligation bond of 50% for the projects.

As Introduced
House Committee on Transportation and Infrastructure, Subcommittee on Water Resources and Environment

May move this bill to the priority list if moving through the process.

HR 3809 (Davis, D-NC, 1st) – The Cybersecurity for Rural Water Systems Act of 2023

To include cybersecurity technical assistance in the national rural water and wastewater circuit rider program of the Department of Agriculture.

As Introduced
House Committee on Agriculture

Consider Support if moves.

HR 4877 (Lee, D-PA, 12th) – Abandoned Well Remediation and Research Act of 2023

Amends the Energy Policy Act of 2005 to direct the Secretary of Energy to conduct a research, development, and demonstration program concerning abandoned wells.

As Amended during markup.
Reported by the House Science, Space, and Technology Committee (35-0)
To House Committee on Rules

HR 4540 (Cuellar, D-TX 28th) – Water Infrastructure Enhancement Act of 2023

Amends the Safe Drinking Water to enact a grant program to provide for the construction of water infrastructure in rural, small, and poverty-stricken communities. Redefines “poverty-stricken” to include communities where 20% of the population has lived in poverty as defined by the Census Bureau. Infrastructure grants include water pipelines, well upgrades, water tanks, water recycling, and wastewater treatment. Authorizes \$800 million in grant opportunities from FY2024 through FY2029.

As Amended during markup.
House Subcommittee on Environment, Manufacturing, and Critical Materials
House Committee on Energy and Commerce.

Move to Priority List if Reported by the Subcommittee (SUPPORT).



S. 660 (Markey, D-MA) – Water System Threat Resiliency and Preparedness Act of 2023

This bill would require the USEPA to develop and implement guidelines for a public water system (anything with a pipe that might become drinking water or wastewater treatment) for cyber and physical threats.

As Introduced
Senate Committee on Environment and Public Works

S. 802 (Braun, R-IN and Padilla, D-CA) – The Plant Bio-stimulant Act of 2023

This bill would amend the Federal Insecticide, Fungicide, and Rodenticide Act standards to include plant bio-stimulants under the regulations and require soil-health tests to determine the impacts on groundwater. The bill would establish limitations on using plant bio-stimulants based on soil type and impacts on groundwater supplies. The bill would further subject bio-stimulant manufacturers to the certification and labeling requirements under FIFRA at the USEPA.

As Introduced
Senate Committee on Agriculture, Nutrition and Forestry.

S. 806 (Baldwin, D-WI) – The Healthy H2O Act

The bill provides financial assistance to property owners (and non-profits assisting small water systems) for water filtration of contaminant found in groundwater supplies utilized for drinking water purposes. These contaminants include arsenic, nitrates, PFAS/PFOA, VOX and Chrome-6. The program is monitored through the Rural Decentralized Water Systems program at the U.S. Department of Agriculture under the *Consolidated Farm and Rural Development Act*. We have added the bill for tracking (“Watch Bill”) as it may have application/benefits to the de-minimus end-users or small water systems in the IWV Basin. Potential inclusion into the 2023 Farm Bill reauthorization.

As Introduced
Senate Committee on Agriculture, Nutrition and Forestry

S. 2102 (Wyden, D-OR) – Water for Conservation and Farming Act of 2023

A bill to provide for drought preparedness and improved water supply reliability.

As Introduced
Senate Committee on Energy and Natural Resources

S. 2162 (Feinstein, D-CA) – The STREAM Act

A bill to support water infrastructure in Reclamation States.

As Introduced
Senate Committee and Energy and Natural Resources

DOWNGRADED: S. 2166 (Padilla, D-CA) – The Voluntary Land Re-Purposing Act of 2023

Introduced on 06/22/2023

This bill amends the Reclamation States Emergency Drought Relief Act of 1991 and the Omnibus Public Land Management Act of 2009 to provide grants to States and Indian Tribes for programs to repurpose agricultural land to reduce consumptive water use voluntarily and for other purposes. The author does not see a path forward without a California program.

Referred to the Senate Committee on Energy & Natural Resources, Subcommittee on Water

S. 2169 (Wyden, D-OR) – The Watershed Results Act of 2023

Authorizes the Secretary of the Interior to carry out watershed pilots.

As Introduced
Senate Committee on Energy and Natural Resources

S. 2202 (Feinstein, D-CA) – The RAIN Act

A bill to amend the Omnibus Public Land Management Act of 2009 to authorize the modification of transferred works to increase public benefits and other project benefits as part of extraordinary operation and maintenance work.

As Introduced
Senate Committee on Energy and Natural Resources

S. 2250 (Bennett, D-CO) and HR 4902 (Caraveo, D-CO 8th) – The Voluntary Groundwater Conservation Act of 2023

To amend the Food Security Act of 1985 to establish a groundwater conservation easement program.

S. 2250:
As Introduced
Senate Committee on Agriculture, Nutrition and Forestry
HR 4902:
As Introduced
House Committee on Agriculture

S. 2928 (Kelly, D-AZ): Water Infrastructure Subcontractor and Taxpayer Protection Act of 2024

As Introduced 01/22/2024

Adds performance bonding requirements to WIFIA loan programs. Similar legislation to HR 1740. The issue should be considered if sustainability infrastructure requires a WIFIA loan.

Senate Committee on Environment and Public Works

S. 3147 (Ricketts, D-NE): Flood Protection and Infrastructure Resilience Act of 2024

As Introduced 01/22/2024

The bill adds regional conservation programs and infrastructure to eligible projects under the Watershed Protection and Flood Prevention Act.

Senate Committee on Agriculture, Nutrition and Forestry.

NEW: Defense Community Support Program (Association of Defense Communities)

Legislative Proposal – Amendment to the NDAA-25

Provides public agencies with grants to carry out specific quality-of-life programs, including education, workforce training, tailing spouse employment, childcare, afterschool programs, post-military employment training, counseling, and mental health. The City of Ridgecrest has requested an amendment to the proposal expanding mental health to cover “rural health care facilities.” City-requested amendments are under consideration. Ancillary impact to the Groundwater Authority. Support if requested and move to the Priority Bill list for “me too” support of the greater effort. No public position is required.

State of California – 2023-2024 California Session



AB 828 (Connolly, D-12th): SGMA: Managed Wetlands and CSDs

As Amended 01/11/2024

The bill exempts groundwater uses by managed wetlands and small community water systems serving disadvantaged communities (DAC) from specified authorities of groundwater sustainability agencies (GSA) to regulate groundwater pumping under the Sustainable Groundwater Management Act (SGMA). The amendments remove the 10% annual increase in allocation and establish a 2028 sunset date. Consistent with SGMA and current Authority practices. No public position, remain as “Watch.”

Passed Assembly (47-15)
Senate Committee on Rules (awaiting referral)

AB 1205 (Bauer-Kahan, D-16th): Water Rights Transfers – Study Bill

As Amended 07/13/2023

AB 1205 would require the SWRCB to conduct a three-year study on the potential profiteering in the sale, transfer, or lease of an interest in any water right for profit on or below agricultural lands. The bill is a two-year bill. Opposition was removed, and the bill was downgraded to “Watch.” No public position.

Senate Floor – To Inactive File (two-year bill)

AMENDED IN: AB 2592 (Grayson, D-15th): Local Planning: Housing Elements: Water and Sewer

As Amended 03/20/2024

Requires each public agency or private entity providing water or sewer services to grant a priority for the provision of these services to proposed housing developments, which the bill would define for these purposes to include both housing developments that include units sold or rented to lower-income households, as provided in existing law as described above, and housing developments constructed pursuant to specified laws providing for ministerial approval of certain housing developments or subdivision maps. The bill would also update the compliance date to adopt written policies and procedures to July 1, 2025, and continue to require adopting those written policies and procedures at least once every 5 years thereafter. Further requires the water use projections to include projected water use for single-family and multifamily residential housing for proposed housing developments, defined as described above, as identified in the housing element of any city, county, or city and county in the service area of the supplier.

Assembly Committee on Housing and Community Development (pending hearing schedule)

NEW ACTION: AB 2715 (Boerner-Horvath, D-77th): Brown Act: Public Agencies

As Introduced 02/15/2024

Authorize closed sessions to consider or evaluate matters related to cybersecurity, as specified, provided that any action taken on those matters is done in an open session.

Assembly Committee on Local Government (awaiting hearing schedule)

AB 3090 (Maienschein, D-76th): Drinking Water Standards: Non-Compliance

As Introduced 02/16/2024

This bill requires the Water District to develop a methodology for notifying customers by wireless communication through the federal Wireless Emergency Alert System in the event of a non-compliance issue [Notification of a boil notice by “Amber Alert”].

Assembly Desk (awaiting referral)

AB 3121 (Hart, D-37th): Urban Water Suppliers: Conservations Orders

As Introduced 02/16/2024

This bill extends the Water Resources Control Board’s required “Conservation Orders” to urban water suppliers by one year, from 2026 to 2027.

Assembly Desk (awaiting referral)

HR 75 (Soria, D-27th): Groundwater Awareness Week

As Introduced 02/26/2024

House Resolution providing specific findings, declarations, and designating the week of March 10th-March 16th as “Groundwater Awareness Week” in the State of California. Resolutions have no force of law and establish a “sense of the Assembly.”

Discharged to the Assembly Floor for Consideration



SB 1110 (Ashby, D-8th): Urban Retail Water Suppliers

As Introduced 02/15/2024

Amends the Water Resources Control Board requirements relative to urban retail suppliers that have not met their urban water management plan to “consider lower cost actions to achieve resiliency.”

Senate Committee on Natural Resources and Water (pending hearing schedule)

NEW: SB 1153 (Hurtado, D-16th): Agricultural Land: Hedge Fund Ownership and Interests

As Introduced 02/14/2024

SB 1153 would prohibit a hedge fund from purchasing, acquiring, leasing, or holding a controlling interest, as defined, in agricultural land within the State of California. The bill would define a “hedge fund,” for these purposes, to mean a privately offered investment vehicle, foreign or domestic, that pools the contributions of private investors in order to invest in a variety of asset classes, such as securities, futures contracts, options, bonds, currencies, real estate, agricultural land, water, energy, and other resources or commodities. This bill would exempt from this prohibition any agricultural land held by a hedge fund before the bill’s effective date. The bill would transfer land in violation of these provisions, subject to divestiture.

Senate Committee on the Judiciary (pending hearing schedule)

Senate Committee on Agriculture (sequential referral)

AMENDED IN: SB 1188 (Laird, D-17th): Drinking Water: Technical, Financial and Managerial Standards

As Amended 03/18/2024

Requires the State Water Resources Control Board to develop minimum standards for small water suppliers with fewer than 10,000 connections related to their technical, managerial, and financial capacity. Creates a new reporting requirement for such water systems. Makes false representation of such capacities a crime. Limits the ability of small water systems that do not meet such standards to receive State money (grants, programmatic funding, etc.).

Senate Committee on Rules (awaiting referral)

SB 1218 (Newman, D-29th): Emergency Water Supplies

As Introduced 02/15/2024

Encourages and incentivizes the development of emergency water supplies by “providers.” While the bill amends the Urban Water Management Plan requirements, it does not limit the development of emergency water supplies to retailers.

Senate Committee on Natural Resources and Water (awaiting hearing schedule)

NEW ACTION: SB 1255 (Durazo, D-26th): Public Water Systems: Needs Analysis

As Introduced 02/15/2024

Requires the Water Resources Control Board to update needs analysis requirements and perform a needs analysis annually (rather than on a three-year basis). Increases regulatory requirements on the water district to update needs analysis annually.

Hearing Scheduled April 24, 2024: Senate Committee on Environmental Quality

NEW ACTION: SB 1330 (Archuleta, D-30th): Urban Retail Water Plans

As Amended 03/20/2024

Requires the State Board to develop an eligible variance list for items that would impact an urban water use management plan. Urban retail suppliers are required to apply for such variance and report it annually to the board. Amendments remove proposed irrigation calculation requirements and set penalties for urban retail water suppliers that do not meet State Board calculation requirements. No impact to the Authority; potential impact to the Water District.

Senate Committee on Natural Resources and Water (pending hearing schedule)

NEW ACTION: SB 1366 (Hurtado, D-16th): Real Estate Disclosures: Water Tank Assistance

02/16/2024

Requires the sale of real property to include disclosures if the property received water tank assistance. May impact or discourage emergency provision of water tank assistance provided under the shallow well mitigation or State-provided program.

Hearing Set April 2, 2024: Senate Committee on the Judiciary

SB 1390 (Caballero, D-14th): Groundwater Recharge: Flood Flow Diversions

As Introduced 02/16/2024

Amends 1242.1 of the Water Code extending the current water rights established for flood flow diversion for the purpose of capture and groundwater recharge to 2034.

Senate Committee Natural Resources and Water (pending hearing schedule)

CALIFORNIA “SPOT” BILLS BEING WATCHED



Bills introduced as placeholders making technical and non-substantive changes are known as “spot” bills. These bills are typically held under a specific subject matter to allow for maintenance of the germane rules.

AB 2000 (Mathis, R-CA 33rd): State Water Project: Permits and Licenses Conditions

As Introduced 01/30/2024

Non-substantive modification. Awaiting Amendments.

Assembly Desk (awaiting referral)

AB 2214 (Bauer-Kahan, D-16th): Resource Conservation Districts

As Introduced 02/07/2024

Makes non-substantive changes. Awaiting Amendments

Assembly Desk (awaiting referral)

AB 2517 (Fong, R-32nd): Water Districts and Irrigation Districts: Debris Removal

As Introduced 02/13/2024

Makes technical and non-substantive changes to the ability of Water Districts and Irrigation Districts to remove debris from ditches and channels. Awaiting Amendments

Assembly Desk (awaiting referral)

AB 2894 (Gallagher, D-3rd): Urban Water Use Targets: Indoor Water Utilization

As Introduced 02/15/2024

Makes non-substantive changes to 10608.2 of the Water Code. Awaiting Amendments

Assembly Desk (awaiting referral)

AB 3012 (Grayson, D-15th): Local Government: Water Supply

As Introduced 02/16/2024

Makes non-substantive changes to Section 38742 of the Government Code related to the ability of a local government to provide retail water supply. Awaiting Amendments

Assembly Desk (awaiting referral)

AB 3084 (Soria, D-27th): Sustainable Groundwater Management Act: Basin Management

“Spot Bill” making non-substantive changes to SGMA (no section identified) regarding groundwater sustainability plans. The author indicates this was a true placeholder bill and does not have any pending amendments. Holding the bill on the “Watch List” until the pending deadline.

Assembly Desk (awaiting referral)

AB 3187 (Carrillo, D-39th): Safe Drinking Water Act

As Introduced 02/16/2024

Makes non-substantive changes to the California Safe Drinking Water Act. Awaiting Amendments

Assembly Desk (awaiting referral)

FY2024-2025 CALIFORNIA STATE BUDGET



State Budget Act for Fiscal Year 2024-2025

The California State Budget includes several pieces of Legislation ranging from the main State Budget (required by the State Constitution to be passed before midnight 06.30.2024) to several “trailing” pieces of legislation. The details of the California State Budget can be found [here](#).

AB 1812/SB 917: State Budget Act of 2024-2025

As Introduced 01/10/2024

Governor’s Budget Proposal – “at the request” legislation. See the summary [here](#).

Assembly Committee and Senate Committee on Budget, respectively.

LEGISLATIVE ANALYST OFFICE (LAO): The updated fiscal analysis for February 20, 2024, can be found [here](#). It shows a \$78 billion State Budget Deficit.

NEW/PRIORITY: FY2024-2025 State Budget Act (Asm. Fong, Sen. Grove, Sen. Atkins): IWVGA State Budget Request

The request is pending with Assembly Member Fong, Senator Grove, and Senator Atkins.

Requests \$2.3 million in FY2024-2025 funding (earmark) for planning activities related to the interconnection pipeline project. The Assembly Committee on Budget has not opened up Member Request but is anticipating Member requests for the Fiscal Year. The Senate Committee on Budget is considering the LAO request to eliminate Member requests for the Fiscal Year.

Request Pending in the Members' Offices.

UPCOMING CALIFORNIA LEGISLATIVE DEADLINES OF IMPORTANCE

- April 26, 2024 – Policy Committee Deadline for 2024 bills.

FISCAL YEAR 2025 FEDERAL APPROPRIATIONS



None on File.

NEW: CONGRESSIONAL DEADLINE: Legislatively-Directed Spending Requests

Member requests opened on March 11, 2024, and have no date for closure at this time.

NEW/PRIORITY: Energy & Water Development Appropriations Act for Fiscal Year 2025: Community Project Funding Request (Oberholte, R-CA 22nd): IWVGA Request

Requests \$1.6 million in appropriation to redirect U.S. Army Corps of Engineers Assistance, as required in WRDA-22, for planning activities related to watershed management (GSA update), validation of specific groundwater studies, and assistance with watershed planning in future years.

The request is pending with Representative Oberholte's office.

FISCAL YEAR 2024 FEDERAL APPROPRIATIONS



NEW: DRAFT LEGISLATION: Spending Appropriations for Remaining Agencies Appropriations Act for Fiscal Year 2024

Providing continuing spending for six (6) agencies for the remainder of Fiscal Year 2024. A \$1.2 trillion spending package for the Department of Defense, Homeland Security, Financial Services, Labor-Health and Human Services, Legislative Branch, and State and Foreign Operations.

Awaiting Introduction in the House of Representatives

NEW: HR 7463 (Granger, R-TX 12th): The Extension of Continuing Appropriations and Other Matters Act of 2024

Making continuing appropriations for Fiscal Year 2024. The 5th CR for the FY2024 Budget.

Public Law 118-40

AMENDED IN: HR 4366 (Carter, R-TX 31st): Minibus Federal Appropriations for FY 2024 Act

Appropriations for FY 2024 are being made for the Agriculture-FDA, Commerce-Justice-Science, Energy and Water Development, Interior and Environment, Military Construction and VA, and Transportation Housing & Urban Development Acts.

As Amended 04/06/2024

Signed by the President – Public Law 118-42

Conference Report Adopted

Passed Senate 82-15

Passed House of Representatives 339-85

FEDERAL REGULATIONS BEING TRACKED

None at this time.

STATE REGULATIONS BEING TRACKED

None at this time.



BILLS TO BE REMOVED FROM THE REPORT

FINAL ACTION: HR 4394 (Fleischman, R-TN 3rd) and **S. 2443** (Feinstein, D-CA) – The Energy & Water Development Act for Fiscal Year 2024

Appropriations for energy and water projects for Fiscal Year 2024. There are no provisions of specific interest to the Authority. Monitor for appropriated amounts to WaterSMART, Environmental Infrastructure, and Planning Assistance.

Incorporated into HR 4366 and adopted Conference Report 03/06/2024 (no further action).

AMENDED OUT: AB 2962 (Papin, D-21st): Water Rights

As Introduced 02/16/2024

“Spot Bill” making non-substantive changes to Section 1250 of the Water Code. Awaiting Amendments. The author’s office has circulated the Fact Sheet on the Legislation with Committee Members. The bill would extend the Bay Area Water Supply and Conservation Agency’s sunset date by ten years. It would have no impact on State water rights or IWVGA. It has been removed from the list.

Assembly Desk (awaiting referral)

[Current Text](#)

AMENDED OUT: SB 1185 (Niello, R-6th): Water Use Efficiency Standards

As Amended 03/018/2024

This bill is a cleanup/implementation bill for the “Make Conservation a California Way of Life” framework. The Legislative Analyst’s Office released a detailed report on the framework earlier this year, which you can view [here](#). Implementing this bill is complicated because multiple agencies are working on policy directives. So, this bill is looking to address some of those implementation issues. **Specifically, it will pertain to landscape efficiency standards.** Senator Niello is apparently concerned that the water-efficient landscaping guidelines that the Department of Water Resources is contemplating (I am wondering if these are the CEC guidelines we spoke about yesterday) are already pretty strict, so he wants to ban local governments from implementing water-efficient landscape ordinances that are stricter than the DWR guidelines. Likely to be removed from the list upon amendment.

Senate Committee on Rules (awaiting referral)

AMENDED OUT: SB 1360 (Alvarado-Gil, D-4th): NPDES Permitting: Electrical Projects

As Amended 03/18/2024

Amends the State Porter-Cologne Act requirements dealing with the State Water Resources Control Board permitting of renewable energy projects. Amendments per the Author's description. Remove from the list.

Senate Committee on Rules (awaiting referral)

EOR

The page intentionally blank