

### Design data

Vessel category	Normal pressure	
	Vessel	Jacket
Description of parameter		
Working pressure bar	1.5	-----
Design pressure bar	1.5	-----
Level tesing pressure bar	3	-----
Medium	Beer	-----
Material	SUS 304	-----
Working temperature °C	-10 to +40°C	
Design temperature °C	-10 to +40°C	
Gross volume BBL	12.5	
Net volume BBL	10	
Heat exchanger area m²	-----	
Insulation material	-----	
Insulation thickness mm	-----	
Dry Weight KGS	-----	

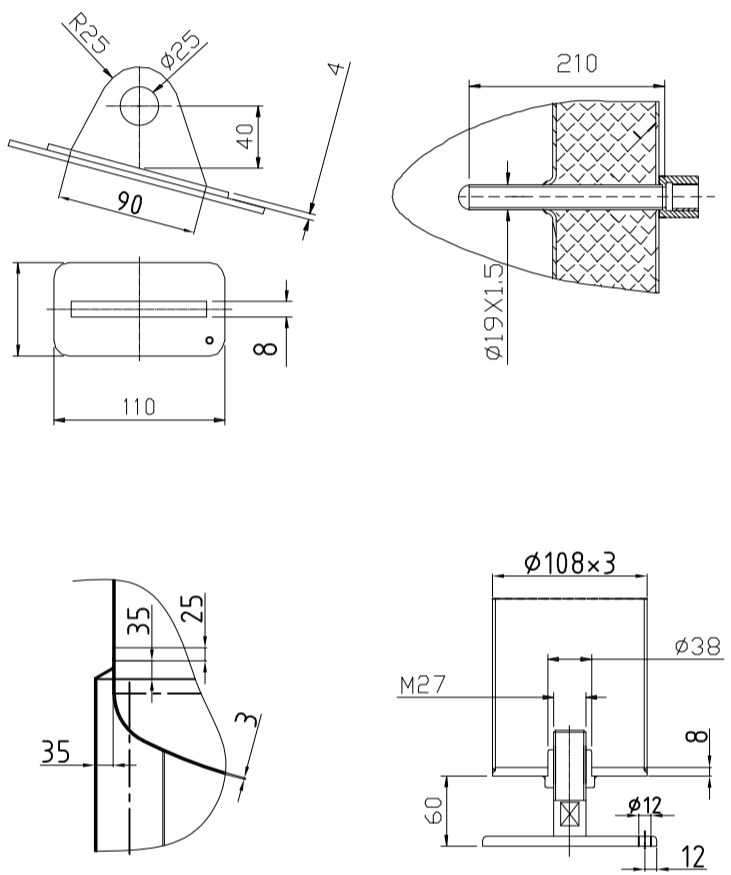

### CONNECTIONS

MARK	DN	DESCRIPTION	CONNECT SIZE	REMARKS
A	2"	PVRV FERRULE	ø50.8x1.5	ISO
B	3"	PORT	ø76.2x1.5	ISO
C	1.5"	CIP APM FERRULE	ø38.1x1.5	ISO
D	1/2"	TEMPERATURE CONN	1/2"	NPT
E	1.5"	CO2 INLET	ø38.1x1.5	ISO
F	1.5"	TEM-GAGE	ø38.1x1.5	ISO
G	1.5"	SAMPLE FERRULE	ø38.1x1.5	ISO
H	1.5"	DIAM ARM COUPLING	ø38.1x1.5	ISO
I	3/4"	DIAM ARM COUPLING	ø19.05x1.5	ISO
J	2"	OUTLET	ø50.8x1.5	ISO
R	21"x17"	MANWAY	530x430	ISO

10BBL BRITE TANK  
(Single Wall)