

Rev.7

Design data

Vessel category	Normal pressure	
	Vessel	Jacket
Description of parameter		
Working pressure	psi	22
Design pressure	psi	22
Level testing pressure	psi	45
Medium	Beer	Glycol
Material	SUS 304	SUS 304
Working temperature	°F	15 to 100
Design temperature	°F	15 to 100
Gross volume	BBL	9.3
Net volume	BBL	7
Heat exchanger area	m2	2.3
Glycol Jacket Max Volume	Gallon	3.2
Insulation material	Chloride Free Polyurethane	
Insulation thickness	mm	80
Total Tank Weight Empty	lbs	738
Total Tank Weight Full	lbs	2548

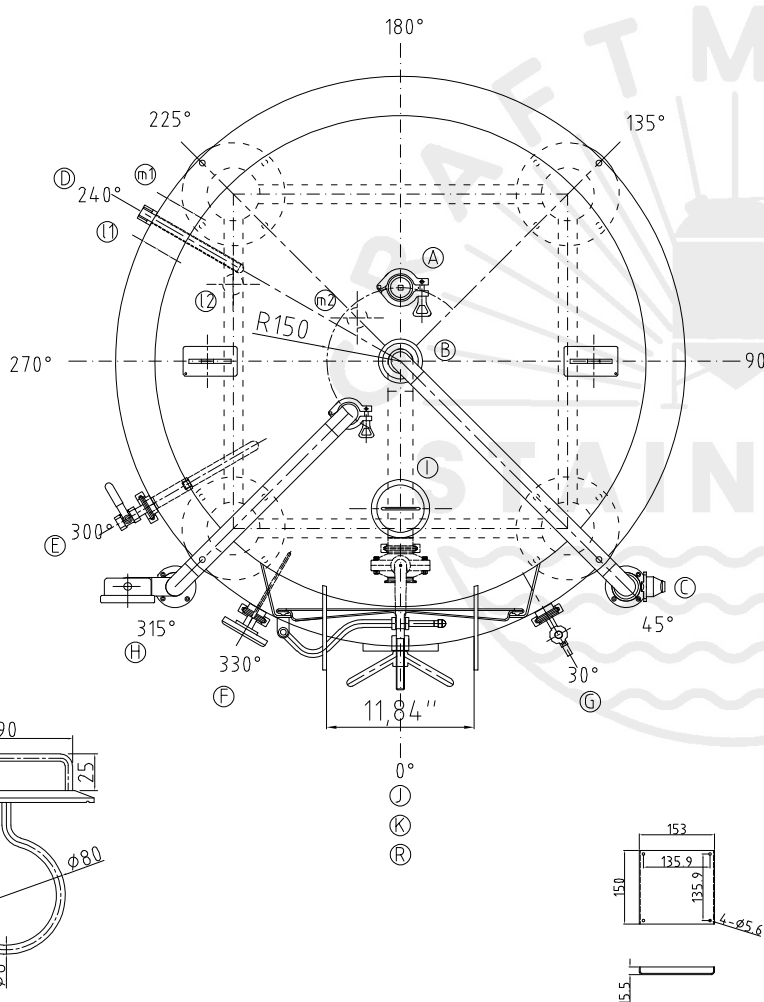
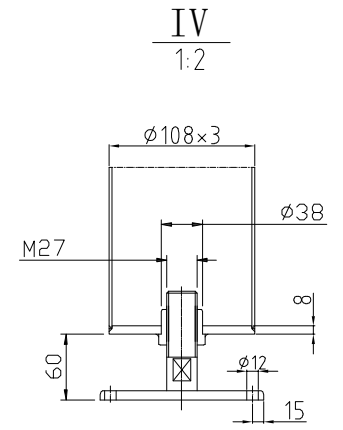
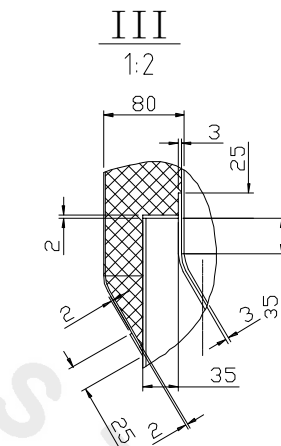
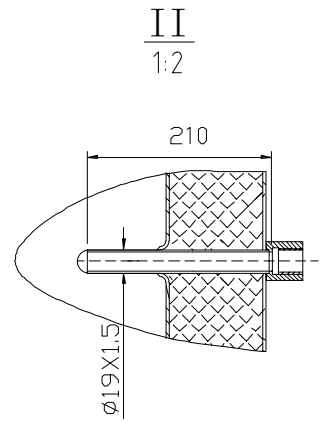
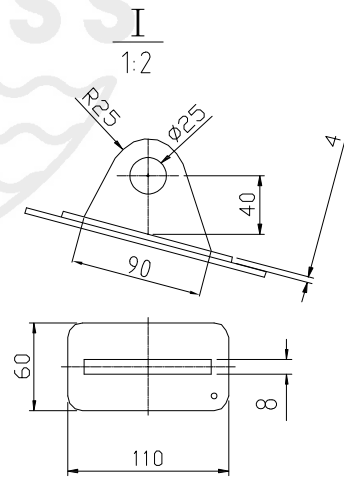
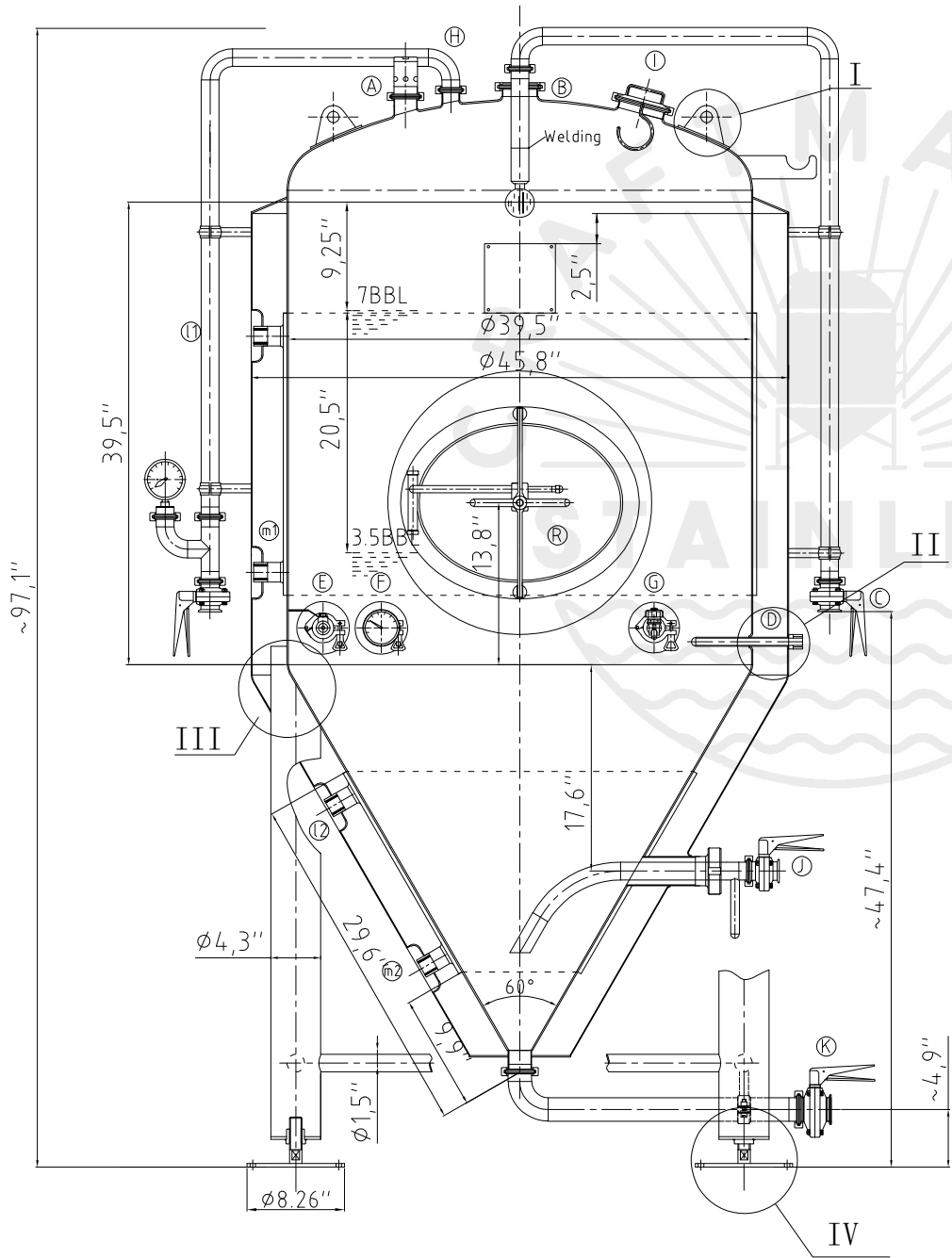

CONNECTIONS

MARK	DN	DESCRIPTION	CONNECT SIZE	REMARKS
A	2"	PVRV FERRULE	2"	ISO
B	3"	PORT	3"	ISO
C	1.5"	CIP APM FERRULE	1.5"	ISO
D	1/2"	TEMPERATURE CONN	1/2"	NPT
E	1.5"	CO2 INLET	1.5"	ISO
F	1.5"	TEM-GAGE	1.5"	ISO
G	1.5"	SAMPLE FERRULE	1.5"	ISO
H	1.5"	OVER FLOW	1.5"	ISO
I	4"	HOP PORT	4"	ISO
J	DIN63-1.5"	DRAIN FERRULE	DIN63-1.5"	ISO
K	2"	OUTLET	2"	ISO
R	21"x17"	MANWAY	21"x17"	ISO
l	3/4"	COOLING OUTLET	3/4"	NPT
m	3/4"	COOLING INLET	3/4"	NPT



04/28/2021

7BBL FERMENTER