

Design data		
Vessel category	Normal pressure	
Description of parameter	Vessel	Jacket
Working pressure	psi	22
Design pressure	psi	22
Level testing pressure	psi	45
Medium	Beer	Glycol
Material	SUS 304	SUS 304
Working temperature	°F 15 to 100	
Design temperature	°F 15 to 100	
Gross volume	BBL	49.2
Net volume	BBL	40
Heat exchanger area	m2	7.5
Glycol Jacket Max Volume	Gallon	10.5
Insulation material	Chloride Free Polyurethane	
Insulation thickness	mm	80
Total Tank Weight Empty	lbs	2160
Total Tank Weight Full	lbs	12504

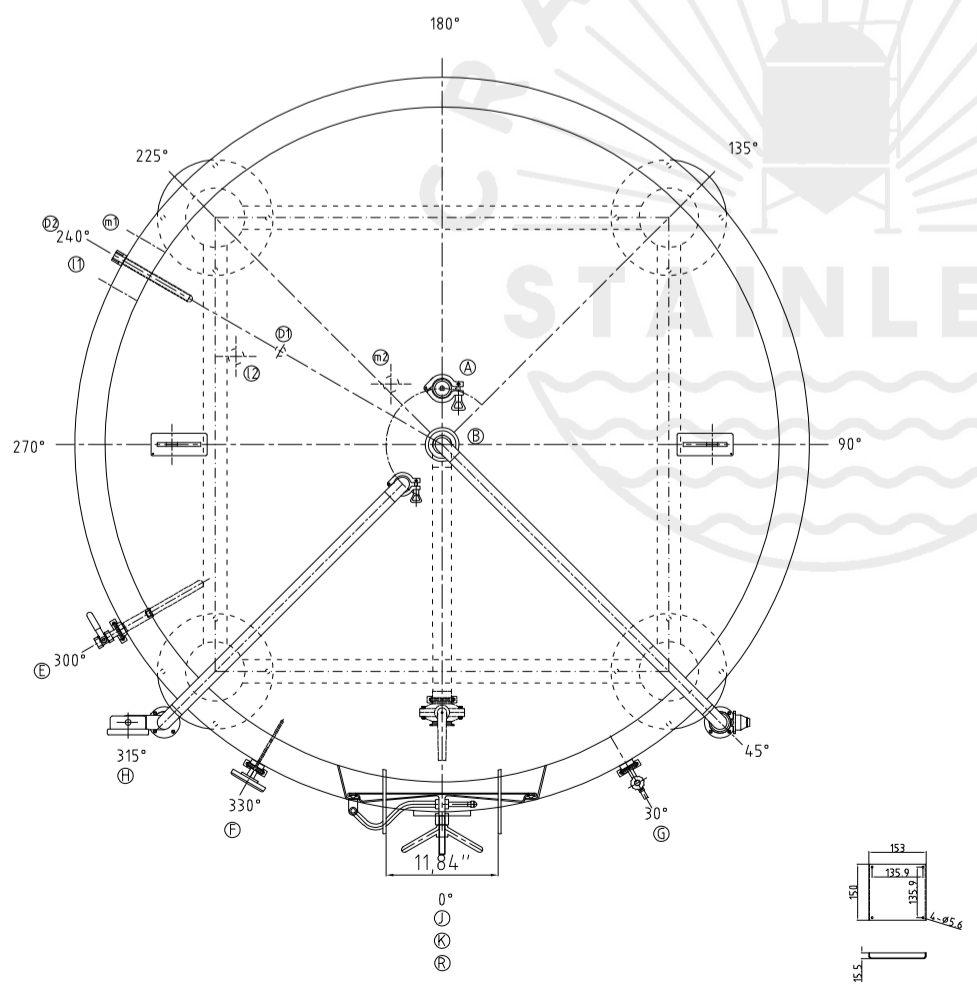

CONNECTIONS				
MARK	DN	DESCRIPTION	CONNECT SIZE	REMARKS
A	2"	PVRV FERRULE	2"	ISO
B	3"	PORT	3"	ISO
C	1.5"	CIP APM FERRULE	1.5"	ISO
D	1/2"	TEMPERATURE CONN	1/2"	NPT
E	1.5"	CO2 INLET	1.5"	ISO
F	1.5"	TEM-GAGE	1.5"	ISO
G	1.5"	SAMPLE FERRULE	1.5"	ISO
H	1.5"	OVER FLOW	1.5"	ISO
J	DIN63-1.5"	DRAIN FERRULE	DIN63-1.5"	ISO
K	2"	OUTLET	2"	ISO
R	21'x17"	MANWAY	21'x17"	ISO
I	3/4"	COOLING OUTLET	3/4"	NPT
m	3/4"	COOLING INLET	3/4"	NPT

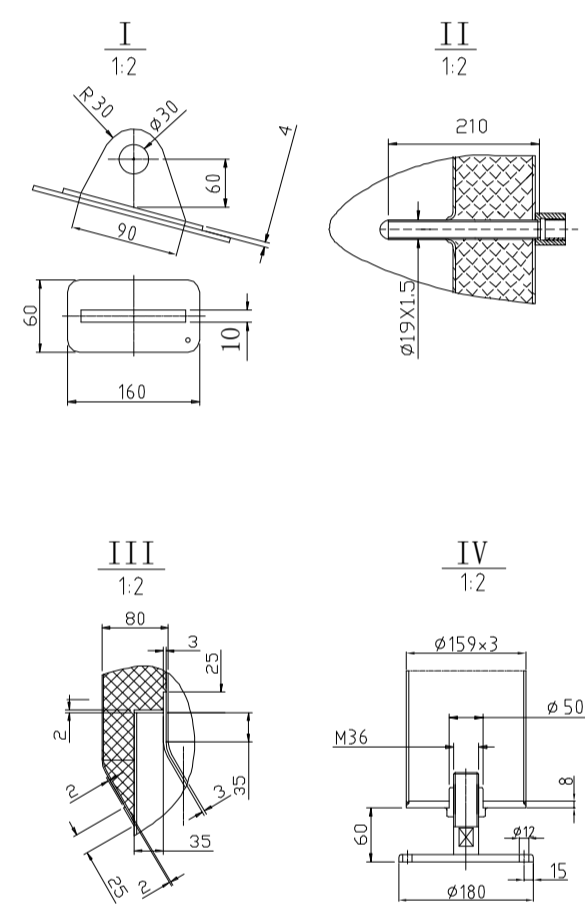

05/25/2021

40BBL FERMENTER