

Design data

Vessel category	Normal pressure	
Description of parameter	Vessel	Jacket
Working pressure	psi 22	psi 45
Design pressure	psi 22	psi 45
Level testing pressure	psi 45	psi 60
Medium	Beer	Glycol
Material	SUS 304	SUS 304
Working temperature	°F 15 to 100	
Design temperature	°F 15 to 100	
Gross volume	BBL 60	
Net volume	BBL 50	
Heat exchanger area	m ² 9.1	
Glycol Jacket Max Volume	Gallon 12.8	
Insulation material	Chloride Free Polyurethane	
Insulation thickness	mm 80	
Total Tank Weight Empty	lbs 2490	
Total Tank Weight Full	lbs 15420	

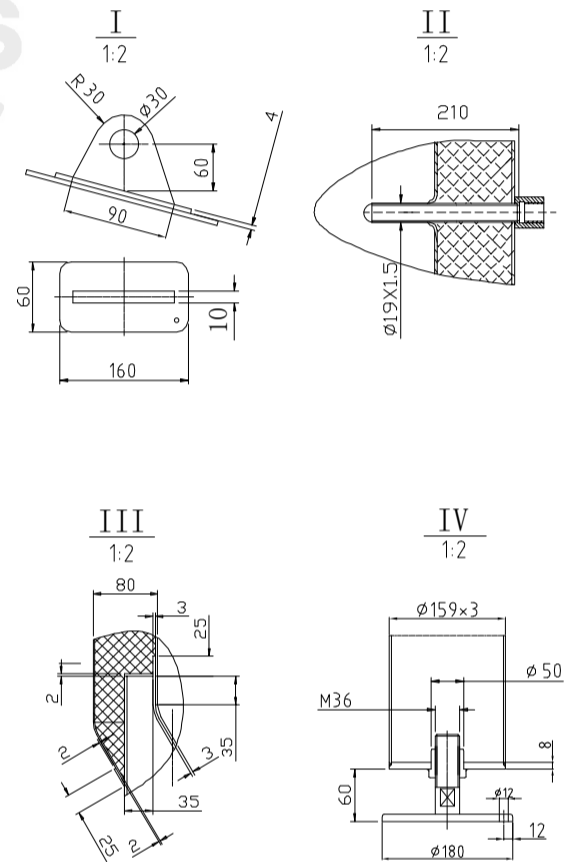

CONNECTIONS

MARK	DN	DESCRIPTION	CONNECT SIZE	REMARKS
A	2"	PVRV FERRULE	2"	ISO
B	3"	PORT	3"	ISO
C	1.5"	CIP APM FERRULE	1.5"	ISO
D	1/2"	TEMPERATURE CONN	1/2"	NPT
E	1.5"	CO2 INLET	1.5"	ISO
F	1.5"	TEM-GAGE	1.5"	ISO
G	1.5"	SAMPLE FERRULE	1.5"	ISO
H	1.5"	OVER FLOW	1.5"	ISO
J	DIN63-1.5"	DRAIN FERRULE	DIN63-1.5"	ISO
K	2"	OUTLET	2"	ISO
R	21"×17"	MANWAY	21"×17"	ISO
l	3/4"	COOLING OUTLET	3/4"	NPT
m	3/4"	COOLING INLET	3/4"	NPT



05/25/2021

50BBL FERMENTER