

Design data

Vessel category	Normal pressure	
Description of parameter	Vessel	Jacket
Working pressure psi	ATMP	45
Design pressure psi	ATMP	45
Level testing pressure psi	ATMP	75
Medium	Malt	Steam
Material	SUS 304	SUS 304
Working temperature °F	15 to 100	
Design temperature °F	15 to 100	
Gross volume BBL	9.6	
Net volume BBL	7	
Heat exchanger area m ²	2.3	
Glycol Jacket Max Volume Gallon	3.2	
Insulation material	Chloride Free Polyurethane	
Insulation thickness mm	80	
Total Tank Weight Empty lbs	1280	
Total Tank Weight Full lbs	3090	

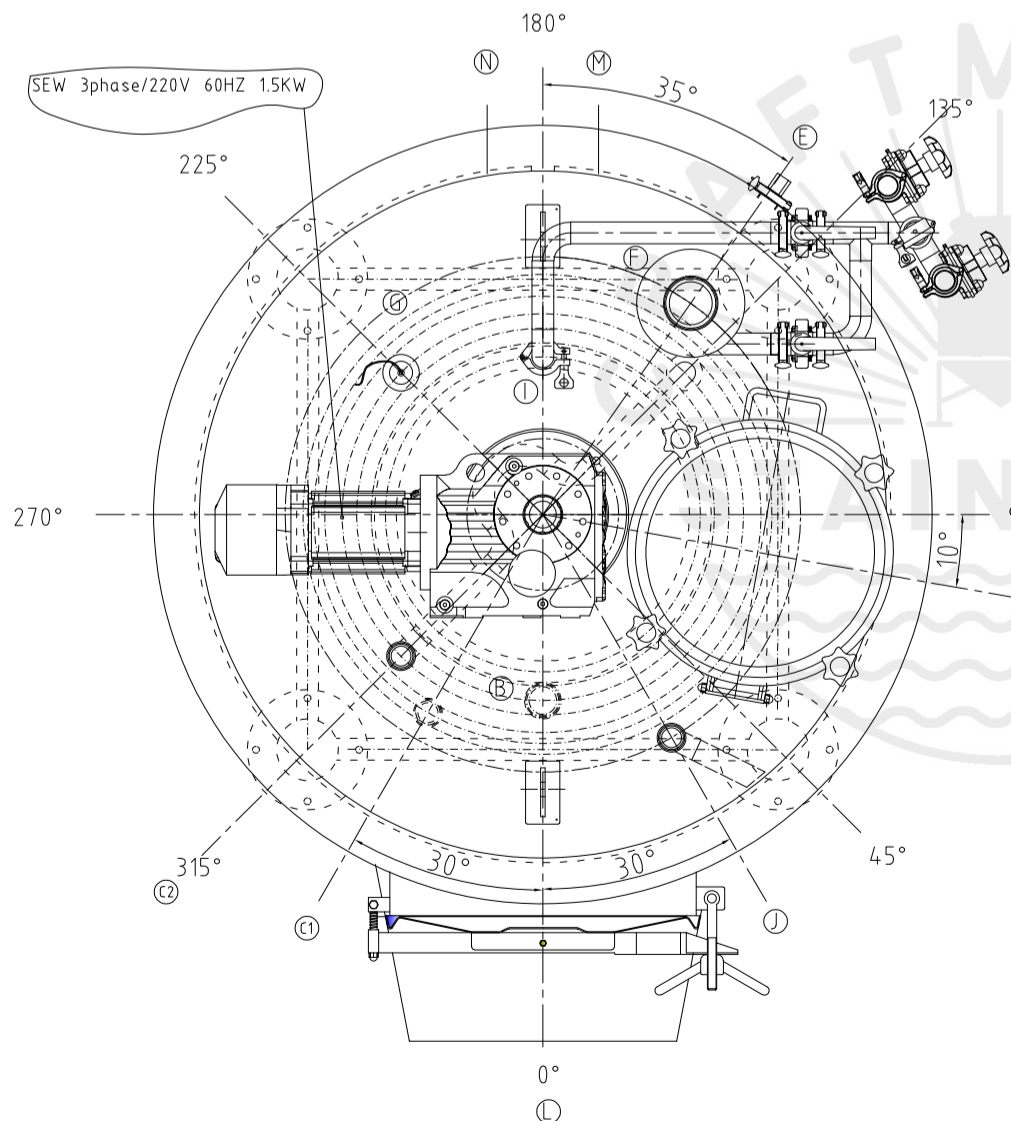
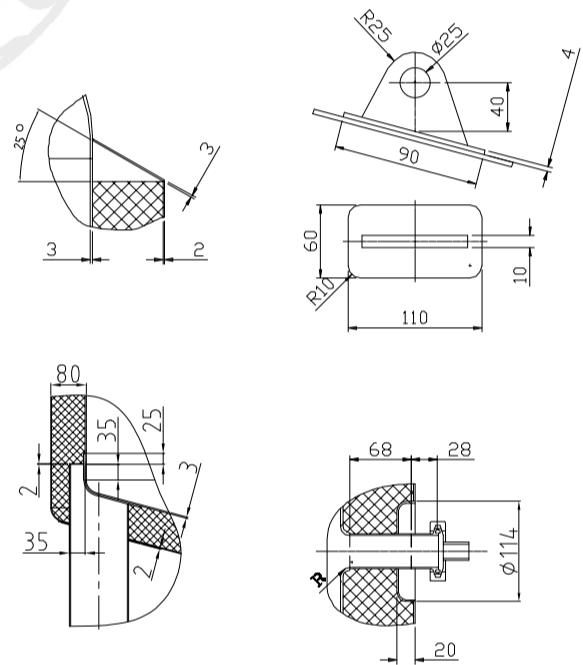

CONNECTIONS

MARK	DN	DESCRIPTION	CONNECT SIZE	REMARKS
A	2"	Yeast outlet	2"	ISO
B	2"	Yeast outlet	2"	ISO
C1-2	1.5"	CIP inlet	1.5"	ISO
D		Underflush nozzles		
E	1.5"	TEM-SENSOR	1.5"	ISO
F	4"	Malt Inlet	4"	ISO
G	2"	Light	2"	ISO
H	11.8"	Motor base	11.8"	ISO
I	1.5"	Spray port	1.5"	ISO
J	1.5"	Inlet	1.5"	ISO
K	φ15.7"	Manway	φ15.7"	ISO
L	21"×17"	Manway	21"×17"	ISO
N	3/4"	Steam Inlet	3/4"	NPT
M	3/4"	Steam outlet	3/4"	NPT



12/21/2021

7BBL MASH LAUTER