

### Design data

Vessel category	Normal pressure	
Description of parameter	Vessel	Jacket
Working pressure	psi	ATMP
Design pressure	psi	ATMP
Level testing pressure	psi	ATMP
Medium	Malt	Steam
Material	SUS 304	SUS 304
Working temperature	°F 15 to 100	
Design temperature	°F 15 to 100	
Gross volume	BBL	13
Net volume	BBL	10
Heat exchanger area	m <sup>2</sup>	3.1
Glycol Jacket Max Volume	Gallon	4.3
Insulation material	Chloride Free Polyurethane	
Insulation thickness	mm	80
Total Tank Weight Empty	lbs	1460
Total Tank Weight Full	lbs	4050

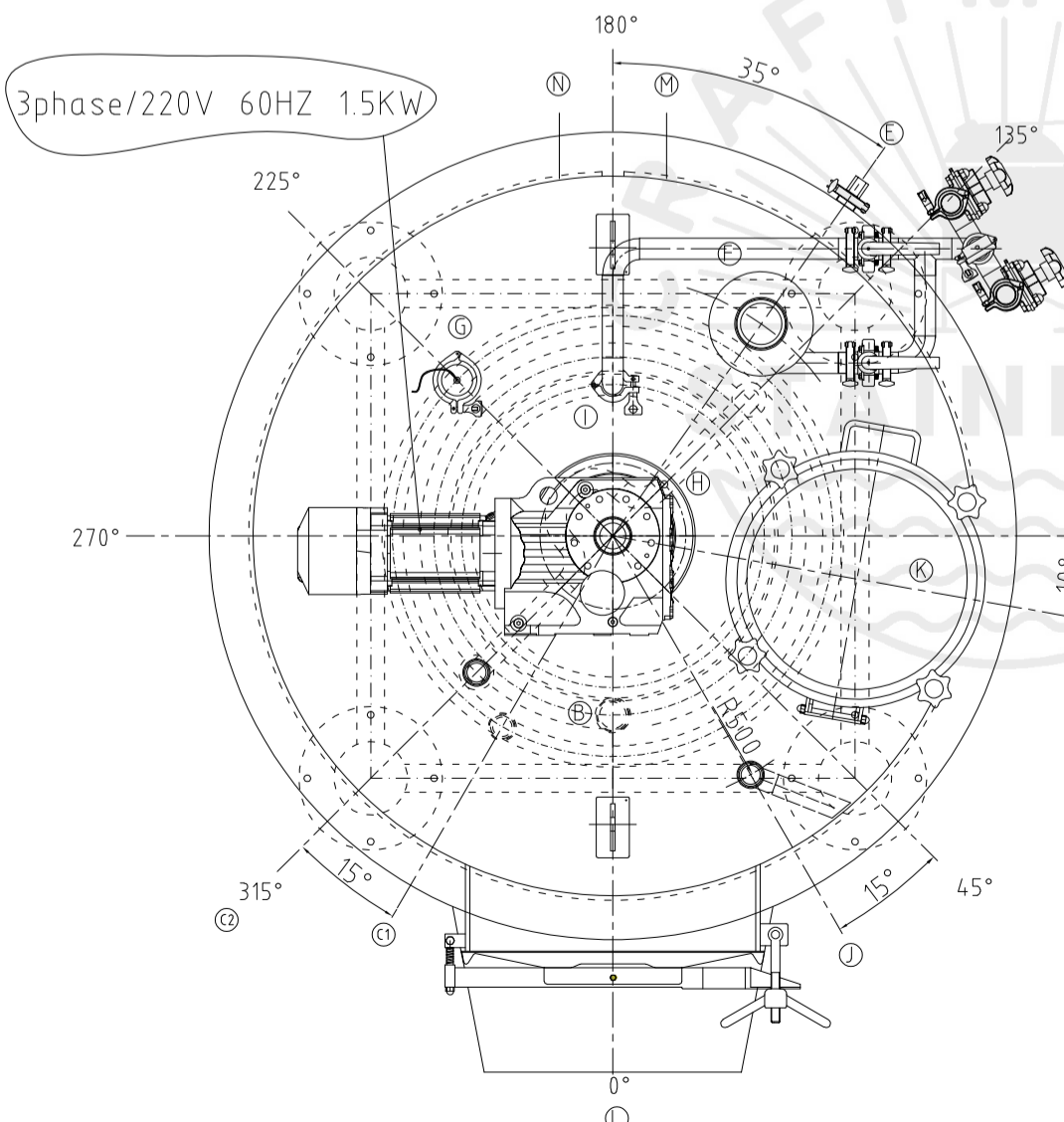
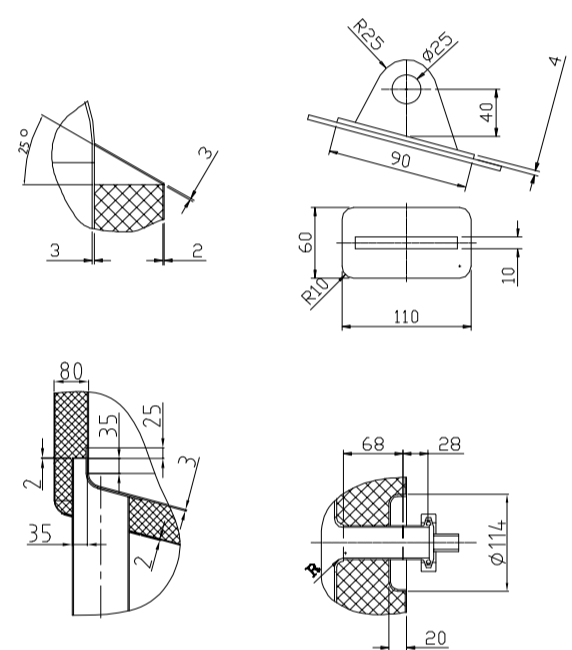

### CONNECTIONS

MARK	DN	DESCRIPTION	CONNECT SIZE	REMARKS
A	2"	Yeast outlet	2"	ISO
B	2"	Yeast outlet	2"	ISO
C1-2	1.5"	CIP inlet	1.5"	ISO
D		Underflush nozzles		
E	1.5"	TEM-SENSOR	1.5"	ISO
F	4"	Malt Inlet	4"	ISO
G	2"	Light	2"	ISO
H	11.8"	Motor base	11.8"	ISO
I	1.5"	Spray port	1.5"	ISO
J	1.5"	Inlet	1.5"	ISO
K	φ15.7"	Manway	φ15.7"	ISO
L	21"×17"	Manway	21"×17"	ISO
N	3/4"	Steam Inlet	3/4"	NPT
M	3/4"	Steam outlet	3/4"	NPT



12/21/2021

10BBL MASH LAUTER