

Design data

Description of parameter	Normal pressure	
	Vessel	Jacket
Working pressure	psi	ATMP
Design pressure	psi	ATMP
Level testing pressure	psi	ATMP
Medium	Malt	Steam
Material	SUS 304	SUS 304
Working temperature	°F	15 to 250
Design temperature	°F	15 to 250
Gross volume	BBL	20
Net volume	BBL	15
Heat exchanger area	m ²	4.6
Glycol Jacket Max Volume	Gallon	6.4
Insulation material	Chloride Free Polyurethane	
Insulation thickness	mm	80
Total Tank Weight Empty	lbs	1660
Total Tank Weight Full	lbs	5540

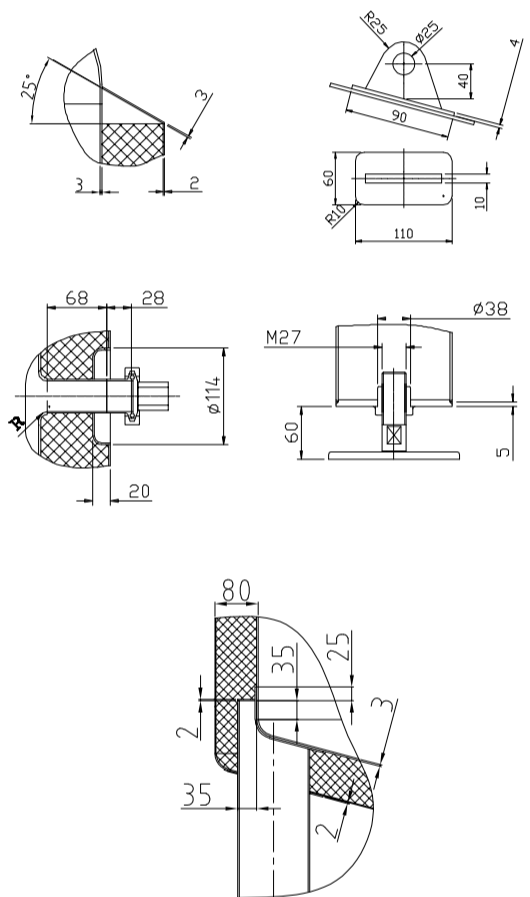

CONNECTIONS

MARK	DN	DESCRIPTION	CONNECT SIZE	REMARKS
A	2"	Yeast outlet	2"	ISO
B	2"	Yeast outlet	2"	ISO
C1-2	1.5"	CIP inlet	1.5"	ISO
D		Underflush nozzles		
E	1.5"	TEM-SENSOR	1.5"	ISO
F	4"	Malt Inlet	4"	ISO
G	DN80	Light	DN80	ISO
H	11.8"	Motor base	11.8"	ISO
I	1.5"	Spray port	1.5"	ISO
J	1.5"	Inlet	1.5"	ISO
K	φ15.7"	Manway	φ15.7"	ISO
L	21"×17"	Manway	21"×17"	ISO
N	3/4"	Steam Inlet	3/4"	NPT
M	3/4"	Steam outlet	3/4"	NPT



12/21/2021

15BBL MASH LAUTER